

BALDOR® • ***RELIANCE***

Product Information Packet

CDPT3310

.25HP, 1750RPM, DC, 56C, 3320P, TENV, F1

Part Detail							
Revision:	K	Status:	PRD/A	Change #:		Proprietary:	No
Type:	DC	Prod. Type:		Elec. Spec:	33WGZ118	CD Diagram:	CD0194
Enclosure:	TENV	Mfg Plant:		Mech. Spec:	33-2155	Layout:	33LY2155
Frame:	56C	Mounting:	F1	Poles:	///	Created Date:	
Base:	RG	Rotation:	R	Insulation:	F	Eff. Date:	05-07-2012
Field Type:		Literature:		Elec. Diagram:		Replaced By:	

Nameplate NP0891L			
CAT.NO.	CDPT3310		
SPEC.	33-2155Z118		
HP	.25	ENCL	TENV
RPM	1750		
FRAME	56C	TYPE	3320P
ARM V	90	ARM A	2.5
FLD V		FLD A	
INSUL	F	AMB.	40
DUTY	CONT	SUPPLY	1.3
BRG/DE	6203	BRG/ODE	6203
BRUSHES	2/BP5011T01		
		BLANK	IP44
SER.			
BLANK			
APRV-CE	<input checked="" type="checkbox"/>	APRV-CSA	<input checked="" type="checkbox"/>
		APRV-UL	<input checked="" type="checkbox"/>

Parts List		
Part Number	Description	Quantity
SA005103	SA 33-2155Z118	1.000 EA
AA002752	AA 33-2155Z118	1.000 EA
BP5011T01SP	CARBON BRUSH - 33P, 90V	1.000 EA
BP5012A04SP	BRUSH SPRING FOR DC MOTORS	1.000 EA
33CB5000A03	33P BOX & LEAD ASSY	1.000 EA
33GS1006A01	GASKET CONDUIT BOX (LEXIDE)	1.000 EA
51XT0832A08	8-32 X 1/2 TY23 HXWS SLDSR	3.000 EA
51XW0832G07	8-32 X 7/16 TY23 HXWS SLDSR GR	1.000 EA
51XW0832A07	8-32 X .44, TAPTITE II, HEX WSHR SLTD SE	4.000 EA
33EP3101A04	FR ENDPLATE, MACH	1.000 EA
HA6340A01	TG-300 TACH. ADAPTER MACH'D FOR 33 FRAME	1.000 EA
84XN2520J12	1/4-20 X 3/4 SOC.HD CAP SCR	4.000 EA
HW1001A25	LOCKWASHER 1/4, ZINC PLT .493 OD, .255 I	4.000 EA
33CB4507	COVER- 33 TACH. ADAP(CLOWTDR 10478 ORDER	1.000 EA
33GS5000	GASKET-COVER 33 TACH ADAPTER	1.000 EA
51XW0832A07	8-32 X .44, TAPTITE II, HEX WSHR SLTD SE	3.000 EA
XY3824A12	.375-24 UNF-2B HEX NUT	1.000 EA
HW1001A38	LOCKWASHER 3/8, ZINC PLT .688 OD, .382 I	1.000 EA
HW1000A38	WASHER, 3/8" FLAT, SAE Z/P	1.000 EA
18XN0632A16	FLAT HEAD SCREW	2.000 EA
12XN0440A12	4-40X.750 SLOTTED HEX HD CAP ZN	2.000 EA
HW1001A04	WASHER, #4 SPLT LK ZINC	2.000 EA
WD4100A26	HEYCO UNIVERSAL BUSHING P/N 2089, MTG HO	1.000 EA
33CB4501A01SP	BRUSH INSPECTION COVER	2.000 EA

Parts List (continued)		
Part Number	Description	Quantity
33GS1005A01	GASKET, BRUSH INSP. COVERELECTRICLY NON-	2.000 EA
51XW0832A07	8-32 X .44, TAPTITE II, HEX WSHR SLTD SE	4.000 EA
HW5100A03SP	WAVY WASHER (W1543-017)	1.000 EA
33EP3302A10	PU ENDPLATE, MACH	1.000 EA
51XN1032A20	10-32 X 1 1/4 HX WS SL SR	2.000 EA
WD4102A12	SR 6P-4 HEYCO STRN RELIEF OR 23MP06P40 M	1.000 EA
34CB4512	34 CB LID	1.000 EA
34GS1001	GASKET, STD CONDUIT BOX LID (LEXIDE)	1.000 EA
51XW0832A07	8-32 X .44, TAPTITE II, HEX WSHR SLTD SE	4.000 EA
HW2501D13	KEY, 3/16 SQ X 1.375	1.000 EA
HA7000A04	KEY RETAINER 0.625 DIA SHAFTS	1.000 EA
HW3001B02	BRASS CUP WASHER W/GROUND SYMBOL TAB,	1.000 EA
X3B003Z029	TACH TG-300 50V .625BORE W/NOTCH CW	1.000 EA
MG1000G27	MED CHARCOAL METALLIC GREY 400-0096	0.013 GA
10XF0440S02	04-40 X 1/8 TYPE F HEX HD STAINLESS STIC	2.000 EA
33RK5004SP	ROCKERARM	1.000 EA
HA3100S01	THRUBOLT- 10-32 X 8.187 302 OR 303 SS	2.000 EA
MN416A01	TAG-INSTAL-MAINT no wire (1200/bx) 11/14	1.000 EA
LB1119N	WARNING LABEL	1.000 EA
LC0194	CONNECTION LABEL	1.000 EA
NP0891L	NP STD LASER ENGRAVED DC MTRS, UL CSA CE	1.000 EA
27PA1001	PKG GRP, PRINT PK1027A06	1.000 EA

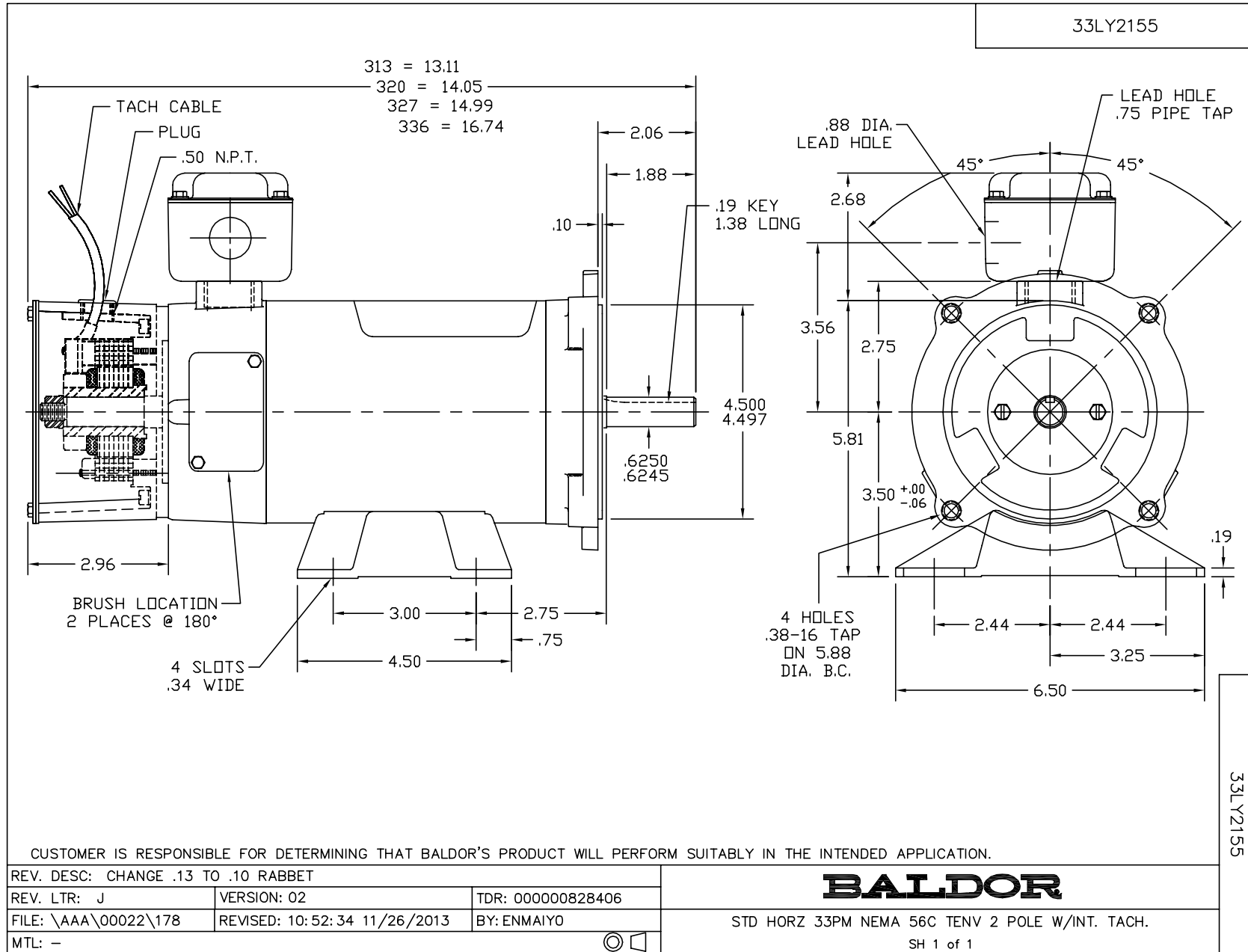

CD0194

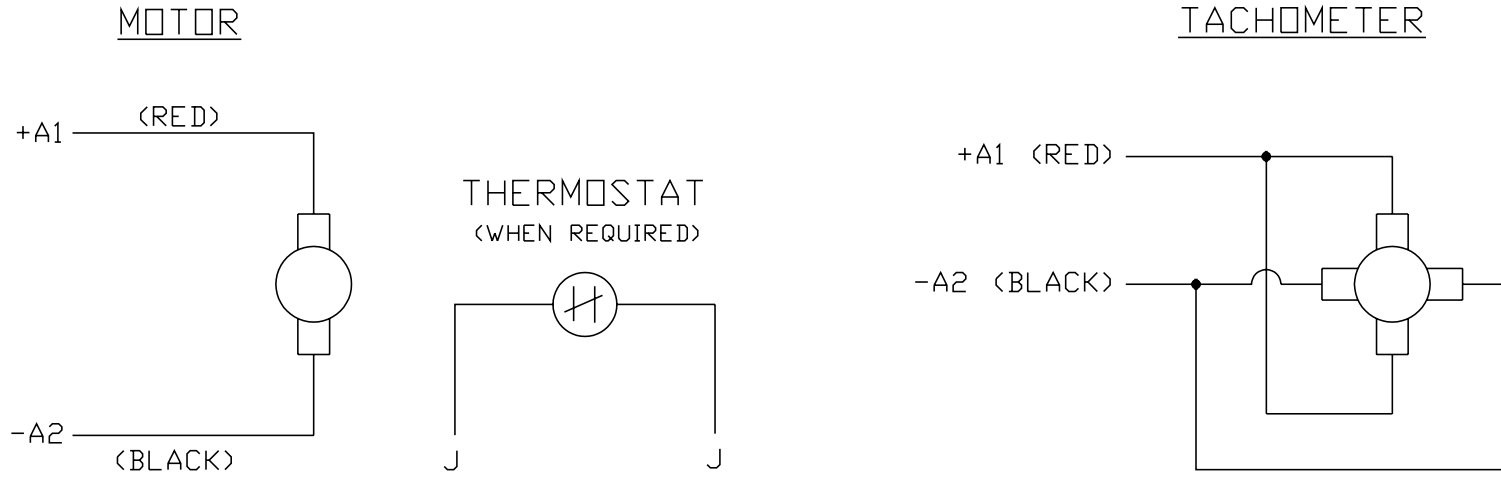

NOTES:

1. CCW ROTATION AS SHOWN FACING COMMUTATOR END. TO REVERSE MOTOR ROTATION OR TACHOMETER OUTPUT POLARITY INTERCHANGE LEADS A1(RED) & A2(BLACK)
2. LEAD COLORS FOR REFERENCE ONLY & NOT SPECIFIED BY THIS DRAWING. LEAD COLORS SPECIFIED BY LAYOUT DRAWING & BILL OF MATERIAL ONLY.

MATL: -			
REV: E	ADDED NOTE "LEAD COLORS FOR REFERENCE ONLY &..."		
761000 CD0194	SCALE: -	BY: CK	REVISED: 07/28/95
	FILE: AAA00004503		TDR: 0078737

BALDOR ELECTRIC Co.

CD TYPE P DC PERMANENT MAGNET MOTORS AND TACHOMETERS

CD0194