

BALDOR® • **RELIANCE**

Product Information Packet

D1154

1HP,1750RPM,DC,56,3535D,TEFC,F1

Part Detail							
Revision:	R	Status:	PRD/A	Change #:		Proprietary:	No
Type:	DC	Prod. Type:		Elec. Spec:	35WGZ396	CD Diagram:	CD0862B01
Enclosure:	TEFC	Mfg Plant:		Mech. Spec:	35P328	Layout:	35LYP328
Frame:	56	Mounting:	F1	Poles:	2///	Created Date:	
Base:	RG	Rotation:	R	Insulation:	F	Eff. Date:	10-26-2016
Field Type:	Compound/stab Shunt	Literature:		Elec. Diagram:		Replaced By:	

Nameplate NP0111L			
CAT.NO.	D1154		
SPEC.	35P328Z396		
HP	1	ENCL	TEFC
RPM	1750		
FRAME	56	TYPE	3535D
ARM V	115	ARM A	8
FLD V	115	FLD A	.5
INSUL	F	AMB.	40
DUTY	CONT	SUPPLY	A
BRG/DE	6205	BRG/ODE	6203
BRUSHES	2/BP5000T07		
SER.	--	BLANK	
BLANK	IEEE 45		
APRV-CSA	<input type="checkbox"/>	APRV-UL	<input type="checkbox"/>

Parts List		
Part Number	Description	Quantity
SA046565	SA 35P328Z396	1.000 EA
AA005342	AA 35P328Z396	1.000 EA
MH2001A01B19	GLASTIC SHEET .093 X 1.188 X	0.126 LB
BP5000T07SP	CARBON BRUSH - SCHUNK GRADE 3971	1.000 EA
11XW1032G06	10-32 X .38, TAPTITE II, HEX WSHR SLTD U	1.000 EA
HW3001B01	BRASS CUP WASHER, FOR #8 SCREW	1.000 EA
35EP1119A06	FR ENDPLATE, MACH	1.000 EA
HW5100A03SP	WAVY WASHER (W1543-017)	1.000 EA
35EP1102A23	PU ENDPLATE, MACH	1.000 EA
51XN1032A20	10-32 X 1 1/4 HX WS SL SR	2.000 EA
80XN1032A03	10-32 X 3/16 SET SCREW	2.000 EA
BP5201A14SP	BRUSH HOLDER ASSY	1.000 EA
MJ5001A27	32220KN GRAY SEALER *MIN BUY 4 QTS=1GAL	0.001 QT
MJ5004A05	#242-21 LOCTITE GENERAL PURPOSE MED. STR	0.001 EA
35FN3002A05	EXFN, PLASTIC, 6.376 OD, .638 ID	1.000 EA
51XB1214A16	12-14X1.00 HXWSSLD SERTYB	1.000 EA
35FH4005A04	IEC FH NO GRSR W/1.09 SHAFT HOLE, W/	1.000 EA
51XW1032A06	10-32 X .38, TAPTITE II, HEX WSHR SLTD S	3.000 EA
WD4100A109	PLUG STIMPSON D3550	1.000 EA
35CB4504	COND. BOX LID 35 DC & PM FRAMES, STAMPED	1.000 EA
35GS1008	GASKET, CONDUIT BOX LID -- 1/16 LEXIDE #	1.000 EA
51XW0832A07	8-32 X .44, TAPTITE II, HEX WSHR SLTD SE	2.000 EA
HA1005A03SP	SLINGER, OD 1.750, ID .938, 205 BRG	1.000 EA
HW2501D13	KEY, 3/16 SQ X 1.375	1.000 EA

Parts List (continued)		
Part Number	Description	Quantity
HA7000A04	KEY RETAINER 0.625 DIA SHAFTS	1.000 EA
MJ5001A27	32220KN GRAY SEALER *MIN BUY 4 QTS=1GAL	0.001 QT
MG1000G27	MED CHARCOAL METALLIC GREY 400-0096	0.017 GA
10XF0440S02	04-40 X 1/8 TYPE F HEX HD STAINLESS STIC	2.000 EA
WD4102A07	STRAIN RELIEF - MICRO PLASTIC #23MP07W20	1.000 EA
HA3100A34	THRUBOLT 10-32 X 11.250	4.000 EA
MN416A01	TAG-INSTAL-MAINT no wire (1200/bx) 11/14	1.000 EA
LB1119N	WARNING LABEL	1.000 EA
NP0111L	NP STD LASER ENGRAVED DC MOTORS, UL CSA	1.000 EA
35PA1007	PKG GRP, PRINT PK1034A06	1.000 EA
LC0862	DC -- COMPOUND WOUND MOTOR CONNECTION LA	1.000 EA

DC Motor Performance Data

Record # 284 - Typical performance - not guaranteed values

Winding: 35WGZ396-R001	Type: 3535D	Enclosure: TEFC
-------------------------------	--------------------	------------------------

Nameplate Data		General Characteristics	
Rated Output (HP)	1	Armature Resistance @ 25°C	0.794 Ω
R.P.M.	1750	Commutating Winding Resistance @ 25°C	0.588 Ω
Armature Volts	115	Series Winding Resistance @ 25°C	1.836 Ω
Armature Amps	8	Shunt Winding Resistance @ 25°C	217 Ω
Field Volts	115	Armature Inductance	14.193 mH
Field Amps	0.5	Armature Inertia	13.68 LI ²
Rating - Duty	40C AMB-CONT		
Power Supply Code	K		
		Temp. Rise @ Rated Load	88°C

Load Characteristics at 115 Armature Volts, 115 Field Volts, 0.52 Field Amps

Load Point	1	2	3	4	5	6	7
Armature Amps	1.1	2.8	4.3	6.2	7.8	9.5	11.3
R.P.M.	1858	1797	1736	1682	1644	1596	1554
Torque (LB-FT)	0	0.75	1.5	2.25	3	3.75	4.5

Performance Graph at 115.0 Arm V, 1.0HP Typical performance - Not guaranteed values

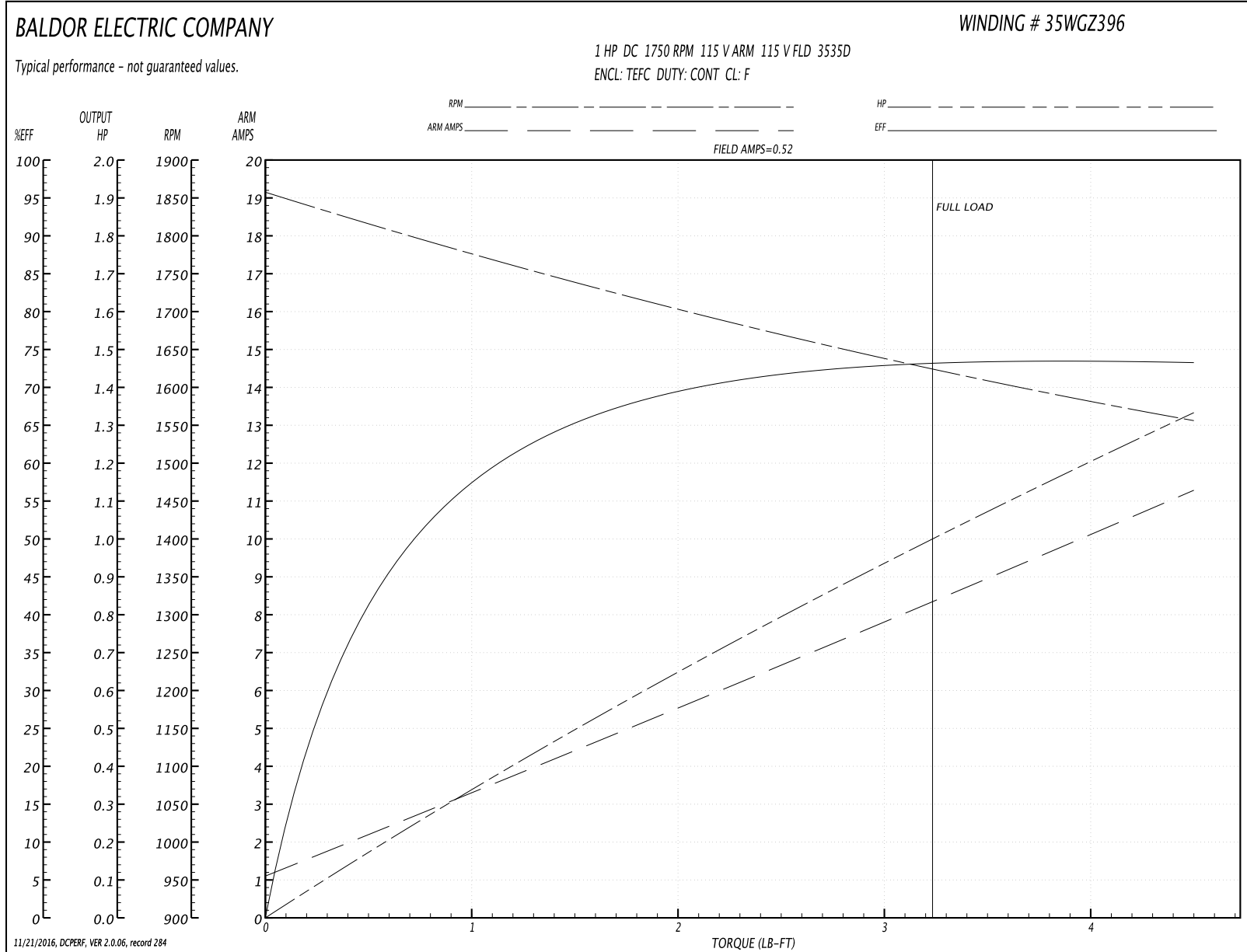

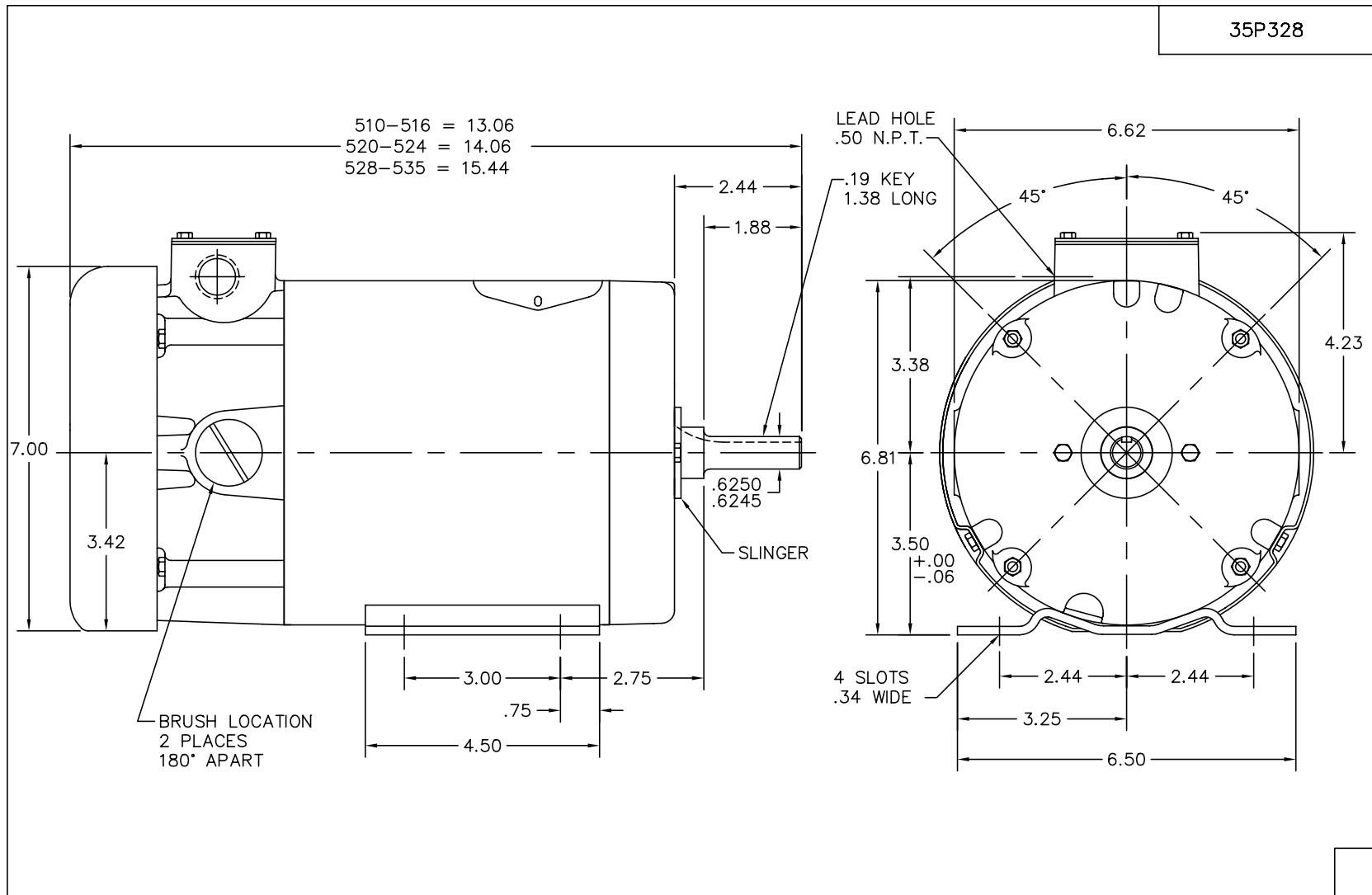

CUST. NAME		CUST. P.O.		CERTIFIED BY		MODEL		INSUL		AMB	
H.P.		MTG		TYPE		R.P.M.		VOLTS		ENCL	
PHASE		FREQ		FRAME		REMARKS:					
REV:	F	LOADED TO ACAD									
35P328		SCALE: .4	BY: TDJ	REVISED: 02/01/96		BALDOR ELECTRIC Co. STD HORZ 35DC NEMA 56 TEFC 2 POLE W/BOLT ON BASE & WP-14-II					
		FILE: AAA00023204	TDR: 0064842								

35P328

CD0862B01

COMPOUND WOUND

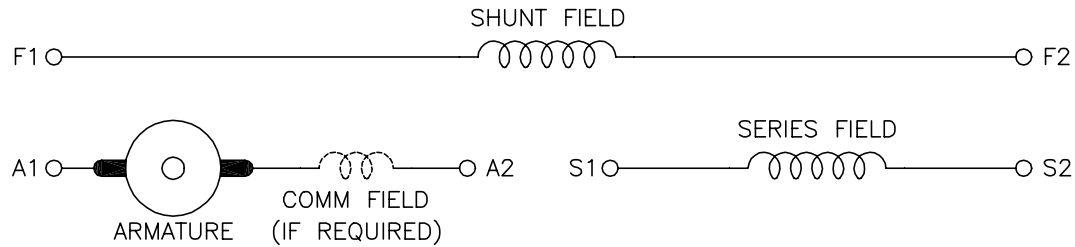

DIRECTION OF ROTATION				
CWDE		CCWDE		
POS TERM (+)	NEG TERM (-)	POS TERM (+)	NEG TERM (-)	
A1	S2	A2	S2	
F1	F2	F1	F2	
CONNECT A2 & S1		CONNECT A1 & S1		

NOTES:

1. LIMIT STARTING INRUSH CURRENT TO NOT MORE THAN 3 TIMES RATED AMPERES BY ENERGIZING THE FULL SHUNT FIELD BEFORE BRINGING THE ARMATURE VOLTAGE UP SLOWLY OR IN STEPS.
2. OPTIONAL FIELD REOSTAT MAY BE CONNECTED IN SERIES WITH THE SHUNT FIELD.
3. OPTIONAL THERMOSTAT LEADS ARE MARKED J,J.

REV. DESC: NEW, REPLACE CD0862

REV. LTR: - BY: JLP REVISED: 16:10:51 11/03/2004 TDR: 347796

10BZ98000
CD0862B01

FILE: AAA00121482 REF: CD0862B01
MTL: -

BALDOR ELECTRIC Co.

DC CONNECTION DIAGRAM, COMPOUND FIELD, 6 LEAD

CD0862B01