

BALDOR® • ***RELIANCE***

Product Information Packet

ECP4400T-5

100HP, 1785RPM, 3PH, 60HZ, 405T, A40064M, TEFC

Part Detail							
Revision:	H	Status:	PRD/A	Change #:		Proprietary:	No
Type:	AC	Prod. Type:	A40064M	Elec. Spec:	A40WG0080	CD Diagram:	416820-036
Enclosure:	TEFC	Mfg Plant:		Mech. Spec:		Layout:	617429-501
Frame:	405T	Mounting:	F1	Poles:	04	Created Date:	07-15-2013
Base:		Rotation:	R	Insulation:	F	Eff. Date:	09-07-2016
Leads:	3#2					Replaced By:	
Literature:		Elec. Diagram:					

Nameplate NP3238									
CAT NO	ECP4400T-5	SPEC NO.	P40G3903						
HP	100	AMPS	89.6	VOLTS	575	DESIGN	B		
FRAME	405T	RPM	1785	HZ	60	AMB	40	SF	1.15
D.E. BRG.DATA	6316	O.D.E. BRG.DATA	6316	PH	3	DUTY	CONT	INSUL.CLASS	F
D.E. BRG.	80BC03J30X	TYPE	P	ENCL	TEFC	CODE	G	NEMA NOM EFFICIENCY	95.4
O.D.E. BRG.	80BC03J30X	POWER FACTOR	87	MAX CORR KVAR	18.00	GUARANTEED EFFICIENCY	94.5		
3/4 LOAD EFF.	95.7	TEMP	= 215						
TEMP CODE	T2D	CT HZ	10-60	VT HZ	0-60				
CHP HZ	60-90								
INVERTER-TEMP-CODE	T2D								
SER.NO.		MOTOR WEIGHT	1326						

Parts List		
Part Number	Description	Quantity
SA267694	SA P40G3903	1.000 EA
RA254364	RA P40G3903	1.000 EA
000692000VD	LABEL WARNING	1.000 EA
NP3238	SS CP XEX SEVERE DUTY MAIN NP	1.000 EA
000692000FF	N/P	1.000 EA
004824015A	GREASE POLYREX EM	0.884 LB
032018008CK	HHCS 3/8-16X1L PLATED	4.000 EA
032018020EK	HHCS 5/8-11X2-1/2 PLTD.	4.000 EA
032018024CK	HHCS 3/8-16X3 PLTD.	3.000 EA
034000014AB	WSH ID.406 OD.812 TH.065	4.000 EA
034180008DA	KEY 1/4X1/4X1 L (shipping)	1.000 EA
034530052AB	P/NIP 1/8X6-1/2 GALV.	1.000 EA
034530056BB	P/NIP 1/4X7 SCHED 40	1.000 EA
034631002AB	BUSH 1/4 TO 1/8 PLTD.	1.000 EA
034690001AB	SQHDPLG, COND	1.000 EA
078548001R	FAN KB 234/150 (84) 400	1.000 EA
034692005AA	P PLUG 3/4"BLK.	1.000 EA
083198101A	G400 STD FAN COVER MACHINING	1.000 EA
089412501A	BRKT FTMT G400 FIN MACH 6316 89412500WCA	1.000 EA
410700000DA	WAVY SPRING WASHER	1.000 EA
415045002B	SLGR	1.000 EA
415072001B	CLAMP	1.000 EA
415096002A	CPLG 1/8 HEX TYPE	1.000 EA
412118006A	DRAIN	1.000 EA

Parts List (continued)		
Part Number	Description	Quantity
032018020EK	HHCS 5/8-11X2-1/2 PLTD.	4.000 EA
032018024CK	HHCS 3/8-16X3 PLTD.	3.000 EA
034530040AB	P/NIP 1/8X5 GALV.	1.000 EA
034530040BB	P/NIP 1/4X5	1.000 EA
034631002AB	BUSH 1/4 TO 1/8 PLTD.	1.000 EA
034690001AB	SQHDPLG, COND	1.000 EA
089412501A	BRKT FTMT G400 FIN MACH 6316 89412500WCA	1.000 EA
415096002A	CPLG 1/8 HEX TYPE	1.000 EA
412118006A	DRAIN	1.000 EA
032018010CK	HHCS 3/8-16X1-1/4 PLTD.	4.000 EA
033512008LB	HHTTS 1/4-20X1 PLATED	4.000 EA
034000014AB	WSH ID.406 OD.812 TH.065	4.000 EA
035000001A	ALFTG 1/8" 1610-BL	1.000 EA
035000001A	ALFTG 1/8" 1610-BL	1.000 EA
065776000C	TERBD 320-400	1.000 EA
067053000B	GASK 320-400	1.000 EA
076708000BB	C/B - 360	1.000 EA
076709000A	C/B - 360	1.000 EA
406099000A	PLUG - FAN COVER 320-440	1.000 EA
415000103H	TERMINAL LUG	1.000 EA
418150003A	GREASE FITTING CAP	1.000 EA
418150003A	GREASE FITTING CAP	1.000 EA
033775004EA	DRSCR #6-1/4 304 S.S.	4.000 EA
034180044JA	KEY 3/4X3/4X5-1/2 L	1.000 EA

Product Information Packet: ECP4400T-5 - 100HP,1785RPM,3PH,60HZ,405T,A40064M,TEFC

MG1025N19	WILKO 778.50 BLUE GREEN - 55 GAL DRUMS	0.375 GA
004824003CBY	WILKO PAINT 060.02 - ACTIVATOR	0.063 GA
421948051	LABEL, MYLAR	1.000 EA
PK5004A02	WOOD BASE 40X32 STACK 2X4 RUNNER	1.000 EA
000613006PU	N/P (RELEASE QTY 10,000) UL CSA LABEL	1.000 EA
LB1449	DIV-2/NEC WARNING LABEL	1.000 EA
032018005DL	1/2-13 X 5/8 SILICON BRONZE HHCS	1.000 EA

REL. S.O.	FRAME	HP	TYPE	PHASE/HERTZ	RPM	VOLTS
	405T	100	P	3/60	1785	575
AMPS	DUTY	AMB °C/ INSUL.	S.F.	NEMA DESIGN	CODE LETTER	ENCL.
89.6	CONT	40/F	1.15	B	G	TEFC
E/S	ROTOR	TEST S.O.	TEST DATE	STATOR RES. @25 °C OHMS (BETWEEN LINES)		
496079	418142-33-RE	---	---	.0770		

PERFORMANCE

LOAD	HP	AMPERES	RPM	POWER FACTOR %	EFFICIENCY %
NO LOAD	0	22.9	1800	5.48	0
1/4	25.0	31.3	1796	64.3	93.0
2/4	50.0	47.5	1792	82.6	95.4
3/4	75.0	67.5	1788	86.9	95.7
4/4	100	89.6	1783	87.6	95.4
5/4	125	113	1778	87.4	94.9

SPEED TORQUE

	RPM	TORQUE % FULL LOAD	TORQUE LB.-FT.	AMPERES
LOCKED ROTOR	0	151	445	580
PULL UP	360	136	400	565
BREAKDOWN	1721	250	735	306
FULL LOAD	1783	100	295	89.6

AMPERES SHOWN FOR 575. VOLT CONNECTION. IF OTHER VOLTAGE CONNECTIONS ARE AVAILABLE, THE AMPERES WILL VARY INVERSELY WITH THE RATED VOLTAGE

REMARKS: TYPICAL DATA
 XE MOTOR-DATA-NEMA NOM. EFF. 95.4 PCT
 GURANTEED MIN EFF. 95.0 PCT

BALDOR	DR. BY P.B. GREENE	A-C MOTOR
	CK. BY K.W. KANOUFF	
APP. BY K.W. KANOUFF	PERFORMANCE DATA	A40WG0080-R003
DATE 12/02/94	ISSUE DATE	12/15/10

REL. S.O. _____ RPM 1785 S.F. 1.15 ROTOR 418142-33-RE
 FRAME 405T VOLTS 575 NEMA DESIGN B TEST S.O. TYPICAL DATA
 HP 100 AMPS 89.6 CODE LETTER G TEST DATE ---
 TYPE P DUTY CONT ENCLOSURE TEFC STATOR RES. @ 25 °C .0770
 PHASE/HERTZ 3/60 AMB °C/INSUL 40/F E/S 496079 OHMS (BETWEEN LINES)

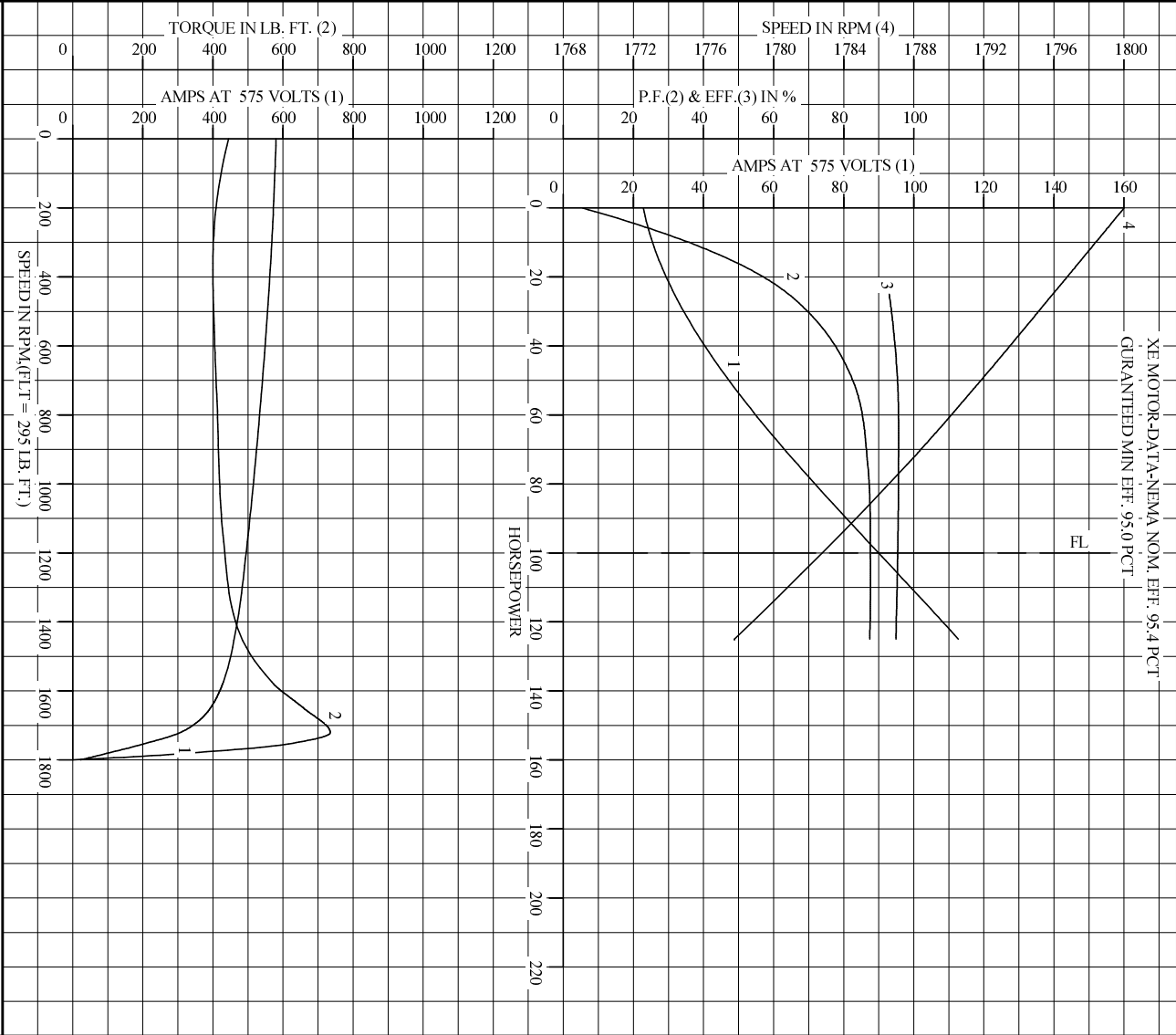

AMPERES SHOWN FOR 575 VOLT CONNECTION, IF OTHER VOLTAGE CONNECTIONS ARE AVAILABLE, THE AMPERES WILL VARY INVERSELY WITH THE RATED VOLTAGE.

BALDOR

DR. BY P.B. GREENE
 CK. BY K.W. KANDOFF
 App. BY K.W. KANDOFF
 DATE 12/02/04

A-C MOTOR PERFORMANCE CURVES A40W/G0080-R003
 ISSUE DATE 12/15/10

Printed on 12/15/10 13:15 @ psecs-motorengr

RET. S.O. RPM 1785 S.F. 1.15 ROTOR 418142-33-RE
 FRAME 405T VOLTS 575 NEMA DESIGN B TEST S.O. TYPICAL DATA
 HP 100 AMPS 89.6 CODE LETTER G TEST DATE ---
 TYPE P DUTY CONT ENCLOSURE TEFC STATOR RES. @ 25 C. 0.770
 PHASE/HERTZ 3/60 AMB C/INSUL 40/F E/S 496079 OHMS (BETWEEN LINES)

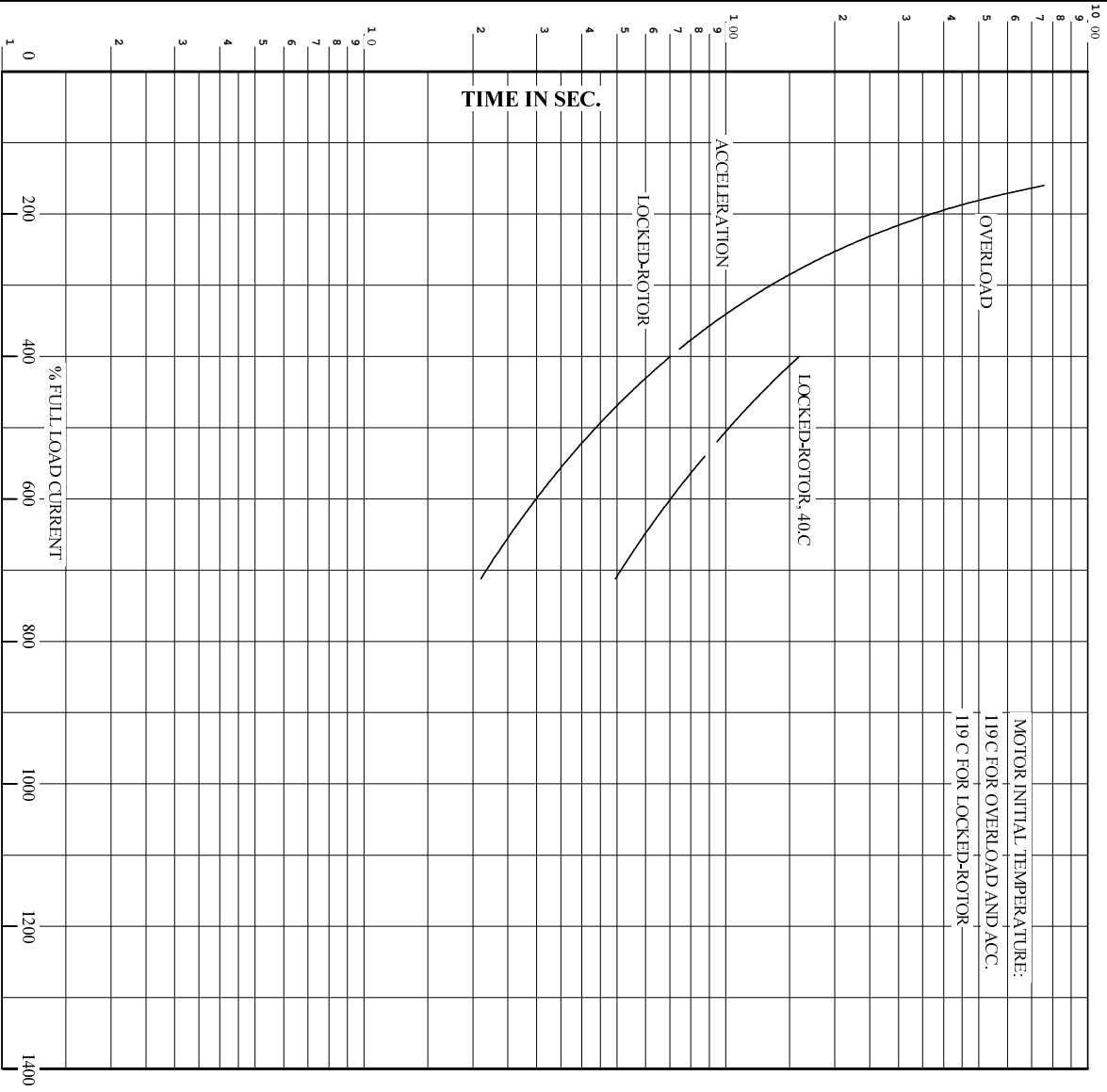

REMARKS: THERMAL LIMIT CURVE
 XE MOTOR-DATA-NEMA NOM. EFF. 95.4 PCT
 GURANTEED MIN EFF. 95.0 PCT

AMPERES SHOWN FOR 575 VOLT CONNECTION, IF OTHER VOLTAGE CONNECTIONS ARE AVAILABLE, THE AMPERES WILL VARY INVERSELY WITH THE RATED VOLTAGE.



DR. BY P.B. GREENE
 CK. BY K.W. KANOUFE
 App. BY K.W. KANOUFE
 DATE 12/02/94

A-C MOTOR
PERFORMANCE
CURVES
A40WG0080-R003
 ISSUE DATE 12/15/10

617429-501

DUTY MASTER ALTERNATING CURRENT MOTORS

SQUIRREL-CAGE INDUCTION

ENCLOSURE: TOTALLY ENCLOSED

FRAME G405T ABOVE NEMA RATINGS

COOLING: FAN COOLED

MOUNTING: FOOT

INCLUDES 404T FRAME MOUNTING HOLES

XT/ECP SEVERE DUTY ENCLOSURE

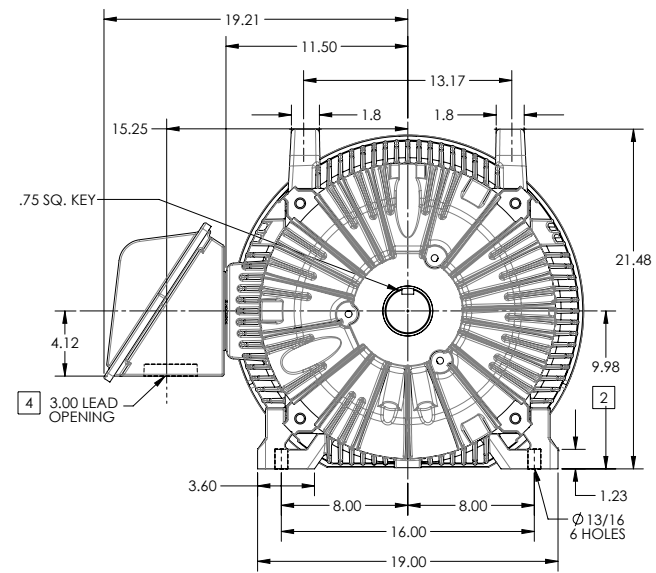
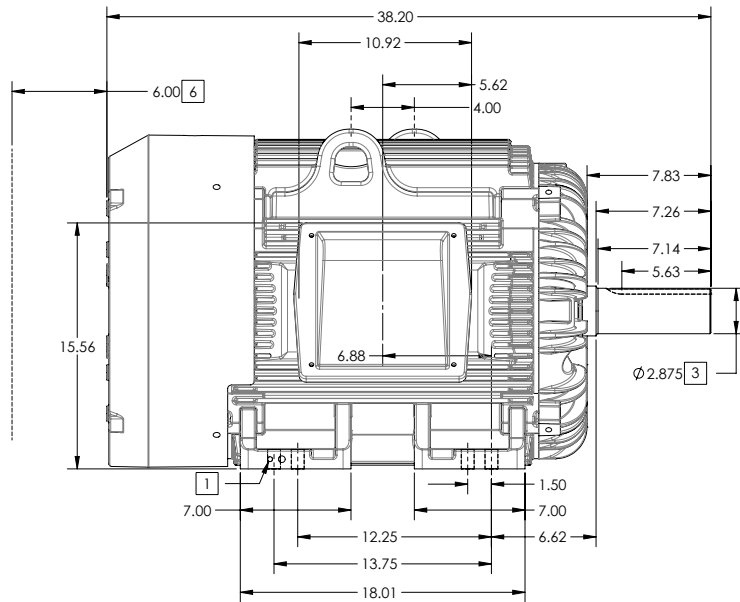

1. GROUND HOLES QTY 1 1/2-13 TAP; QTY 1 3/8-16 TAP
2. VARIES +.00,-.06
3. VARIES +.00,-.001
4. ON STANDARD MOTORS THIS IS CONDUIT SIZE. ON XT AND CORROSION PROOF MOTOR THIS IS PIPE TAP.
5. MOTOR WEIGHTS MAY VARY BY 15% DEPENDING ON RATING.
6. OBSTRUCTION MUST NOT ENCROACH ON AIR INLET

[5] WEIGHT (LBS): 1370

CONDUIT BOX LOCATED ON OPPOSITE SIDE WHEN F-2. IF MOUNTING CLEARANCE DETAILS ARE REQUIRED, CONSULT FACTORY. MAXIMUM PERMISSIBLE SHAFT RUNOUT WHEN MEASURED AT END OF STANDARD SHAFT EXTENSION IS .003" T.I.R. TO 5 INCH DIA.

DIMENSIONS ARE IN INCHES; SEE SHEET 2 FOR DIMENSIONS IN MILLIMETERS

CUSTOMER IS RESPONSIBLE FOR DETERMINING THAT MOTOR PERFORMANCE IS SUITABLE IN THE APPLICATION.

SHEET NUMBER
1 OF 2

105-627219

REV. DESC CHANGE BA FROM 6.76 TO 6.62			
REV: B	VERSION: 02	REVISED: 01-11-16 04/14/2014	TDR: 00000848770
MODEL NO. 617429-501	BY: MGHMMZ	Material:	REF:

BALDOR

G405T/404T STD - FOOTED - XT/ECP SEVERE DUTY ENCLOSURE

617429-501

617429-501

DUTY MASTER ALTERNATING CURRENT MOTORS

SQUIRREL-CAGE INDUCTION

ENCLOSURE: TOTALLY ENCLOSED

FRAME G405T ABOVE NEMA RATINGS

COOLING: FAN COOLED

MOUNTING: FOOT

INCLUDES 404T FRAME MOUNTING HOLES

XT/ECP SEVERE DUTY ENCLOSURE

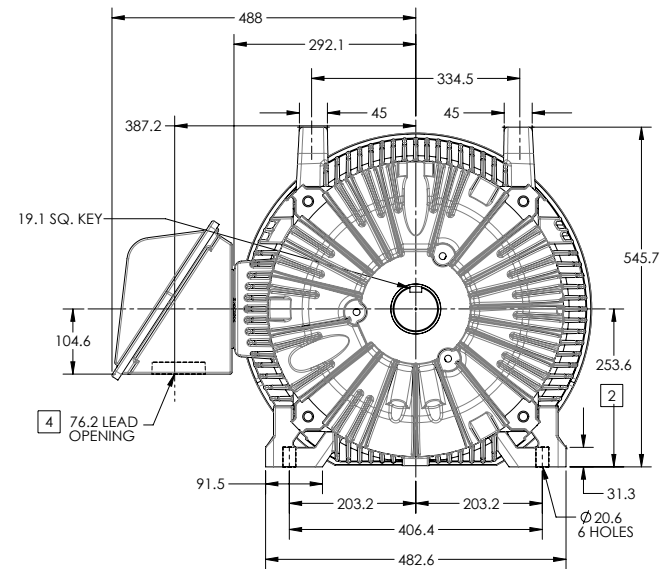
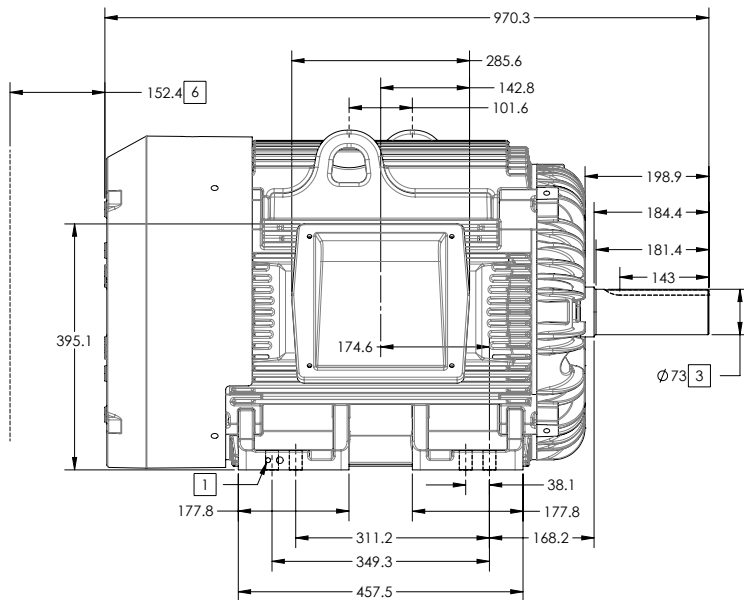

1. GROUND HOLES QTY 1 1/2-13 TAP; QTY 1 3/8-16 TAP
2. VARIES +0,-1.5
3. VARIES +00,-.03
4. ON STANDARD MOTORS THIS IS CONDUIT SIZE. ON XT AND CORROSION PROOF MOTOR THIS IS PIPE TAP.
5. MOTOR WEIGHTS MAY VARY BY 15% DEPENDING ON RATING.
6. OBSTRUCTION MUST NOT ENCROACH ON AIR INLET

[5] WEIGHT (KGS): 630

CONDUIT BOX LOCATED ON OPPOSITE SIDE WHEN F-2.
IF MOUNTING CLEARANCE DETAILS ARE REQUIRED, CONSULT FACTORY.
MAXIMUM PERMISSIBLE SHAFT RUNOUT WHEN MEASURED AT END OF STANDARD SHAFT EXTENSION IS .08 MM T.I.R. TO 127 MM DIA.

DIMENSIONS ARE IN MILLIMETERS; SEE SHEET 1 FOR DIMENSIONS IN INCHES

CUSTOMER IS RESPONSIBLE FOR DETERMINING THAT MOTOR PERFORMANCE IS SUITABLE IN THE APPLICATION.

SHEET NUMBER
2 OF 2

105-627219

REV. DESC: CHANGE BA FROM 6.76 TO 6.62	TDR: 00000848770
REV: B VERSION: 02	REVISED: 01-11-16 04/14/2014
MODEL NO. 617429-501	REF:
BY: MGHMMZ	Material:

BALDOR

G405T/404T STD - FOOTED - XT/ECP SEVERE DUTY ENCLOSURE

617429-501

416820-036

A-C MOTOR
 CONNECTION DIAGRAM
 STANDARD 3 LEAD CONNECTED

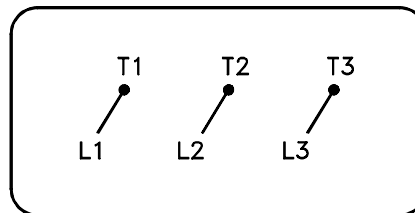

(N.P. 1575-BA)

416820-036

REV. DESC: LOADED TO BUS, C/R 335225		
REV. LTR: -	VERSION: 00	TDR: 000000538207
FILE: \MGA\00000\682	REVISED: 11:54:06 04/30/2010	
MTL: -	BY: RAGRA	

BALDOR

CONN DIAG - STANDARD 3 LEAD

SH 1 of 1

Marketing maintained PDF of MN408:

<http://www.baldor.com/support/Literature/Load.ashx/MN408?ManNumber=MN408>

Marketing maintained PDF of MN416:

<http://www.baldor.com/support/Literature/Load.ashx/MN416?ManNumber=MN416>