

# **BALDOR**® • **RELIANCE**

## **Product Information Packet**

# **WCL1409T**

**5HP,3450RPM,1PH,60HZ,184TCZ,3634L,OPEN**

Part Detail							
Revision:	AD	Status:	PRD/A	Change #:		Proprietary:	No
Type:	AC	Prod. Type:	3634L	Elec. Spec:	36WG0190	CD Diagram:	CD0017A01
Enclosure:	OPEN	Mfg Plant:		Mech. Spec:	36E775	Layout:	36LYE775
Frame:	184TCZ	Mounting:	F1	Poles:	02	Created Date:	
Base:	RG	Rotation:	R	Insulation:	F	Eff. Date:	05-12-2016
Leads:	2#10 A PH,2#16 B PH					Replaced By:	
Literature:		Elec. Diagram:					

Nameplate NP1256L										
CAT.NO.	WCL1409T									
SPEC.	36E775-190									
HP	5									
VOLTS	230									
AMP	23									
RPM	3450									
FRAME	184TCZ				HZ	60			PH	1
SER.F.	1.15		CODE	F	DES	L		CLASS	F	
NEMA-NOM-EFF	75		PF	88						
RATING	40C AMB-CONT									
CC								USABLE AT 208V	24	
DE	6207			ODE	6205					
ENCL	OPEN		SN							

Parts List		
Part Number	Description	Quantity
SA034725	SA 36E775-190	1.000 EA
RA030753	RA 36E775-190	1.000 EA
36CB3004	36 CB CASTING W/1.09 DIA LEAD HOLE @ 6:0	1.000 EA
51XB1016A08	10-16X 1/2HXWSSLD SERTYB	2.000 EA
11XW1032G06	10-32 X .38, TAPTITE II, HEX WSHR SLTD U	1.000 EA
HW3001B01	BRASS CUP WASHER, FOR #8 SCREW	1.000 EA
36FE3200A25	FREP ASSEMBLY FOR ROUTING PURPOSES	1.000 EA
HW4500A01	1641B(ALEMITE)400 UNIV, GREASE FITT	1.000 EA
HW4500A17	317400 ALEMITE GREASE RELIEF	1.000 EA
HA1103A08	RODENT SCREEN, 36 FRAME, OPEN, FRONT END	1.000 EA
51XW1032A06	10-32 X .38, TAPTITE II, HEX WSHR SLTD S	4.000 EA
HW1000A10	#10 FLAT WASHER (SAE)	4.000 EA
HW1000A10	#10 FLAT WASHER (SAE)	4.000 EA
SP1008A01	BAFFLE, MODEL 36 & 37	1.000 EA
13XF0832A08	8-32 X.50 PAN HD,SLTD, TYPE F SCREW, ZIN	2.000 EA
10XN2520A12	O1/4-20X 3/4 HEX HEAD CAP	2.000 EA
HW5100A05	WVY WSHR F/205 & 304 BRGS	1.000 EA
36EP1206A15	PU ENDPLATE, MACH	1.000 EA
HW4500A01	1641B(ALEMITE)400 UNIV, GREASE FITT	1.000 EA
HW4500A17	317400 ALEMITE GREASE RELIEF	1.000 EA
36AD2000	AIR BAFFLE	1.000 EA
85XU0407S04	4X1/4 U DRIVE PIN STAINLESS	4.000 EA
HA1102A09	RODENT SCREEN 36 OPEN FAC	2.000 EA
51XW1032A06	10-32 X .38, TAPTITE II, HEX WSHR SLTD S	4.000 EA

Parts List (continued)		
Part Number	Description	Quantity
10XN2520A26	1/4-20X 1 5/8 HEX HD	4.000 EA
HW1001A25	LOCKWASHER 1/4, ZINC PLT .493 OD, .255 I	4.000 EA
36CB4516	36 LIPPED CB LID	1.000 EA
51XW0832A07	8-32 X .44, TAPTITE II, HEX WSHR SLTD SE	4.000 EA
HA2009A01	36-4613 SL ANOD. ALUM (STER	1.000 EA
80XN1032A06	10-32 X 3/8 SET SC HEX SOCK	1.000 EA
HW2501D13	KEY, 3/16 SQ X 1.375	1.000 EA
HA7000A01	KEY RETAINER 7/8" DIA SHAFT	1.000 EA
85XU0407S04	4X1/4 U DRIVE PIN STAINLESS	2.000 EA
MJ1000A02	GREASE, POLYREX EM EXXON (USe 4824-15A)	0.050 LB
MG1000G27	MED CHARCOAL METALLIC GREY 400-0096	0.022 GA
SP5172A01	37 TYPE L TORQ STAT SWITCH LEAD ASSEMBLY	1.000 EA
36CB5008A01	CAPACITOR BOX KIT, 36CB3800, EC1216C06	1.000 EA
HA3101A25	THRUBOLT 1/4-20 X 11.000 OHIO ROD	4.000 EA
LB1119N	WARNING LABEL	1.000 EA
LC0017	CONN LABEL-1 PHASE-SINGLE VOLT-REV ROTNO	1.000 EA
NP1256L	ALUM UL CSA CC	1.000 EA
G0PA1000	PKG GRP, PRINT PK1026A06	1.000 EA
MN416A01	TAG-INSTAL-MAINT no wire (1200/bx) 11/14	1.000 EA

**AC Induction Motor Performance Data**

Record # 20846 - Typical performance - not guaranteed values

<b>Winding:</b> 36WG0190-R002	<b>Type:</b> 3634L	<b>Enclosure:</b> OPEN
-------------------------------	--------------------	------------------------

Nameplate Data				230 V, 60 Hz: Single Voltage Motor	
Rated Output (HP)	5			Full Load Torque	7.6 LB-FT
Volts	230			Start Configuration	direct on line
Full Load Amps	23			Breakdown Torque	18.7 LB-FT
R.P.M.	3450			Pull-up Torque	16 LB-FT
Hz	60	Phase	1	Locked-rotor Torque	18 LB-FT
NEMA Design Code	L	KVA Code	F	Starting Current	125 A
Service Factor (S.F.)	1.15			No-load Current	9 A
NEMA Nom. Eff.	75	Power Factor	88	Line-line Res. @ 25°C	0.338 Ω A Ph 1.16 Ω B Ph
Rating - Duty	40C AMB-CONT			Temp. Rise @ Rated Load	75°C
S.F. Amps				Temp. Rise @ S.F. Load	90°C

Load Characteristics 230 V, 60 Hz, 5 HP

% of Rated Load	25	50	75	100	125	150	S.F.
Power Factor	59	76	84	88	90	90	0
Efficiency	63	74.5	77.7	78	76.5	73.6	0
Speed	3559	3524	3485	3440	3387	3318	0
Line amperes	10.9	14.3	18.6	23.6	29.6	36.8	27.2

Performance Graph at 230V, 60Hz, 5.0HP Typical performance - Not guaranteed values

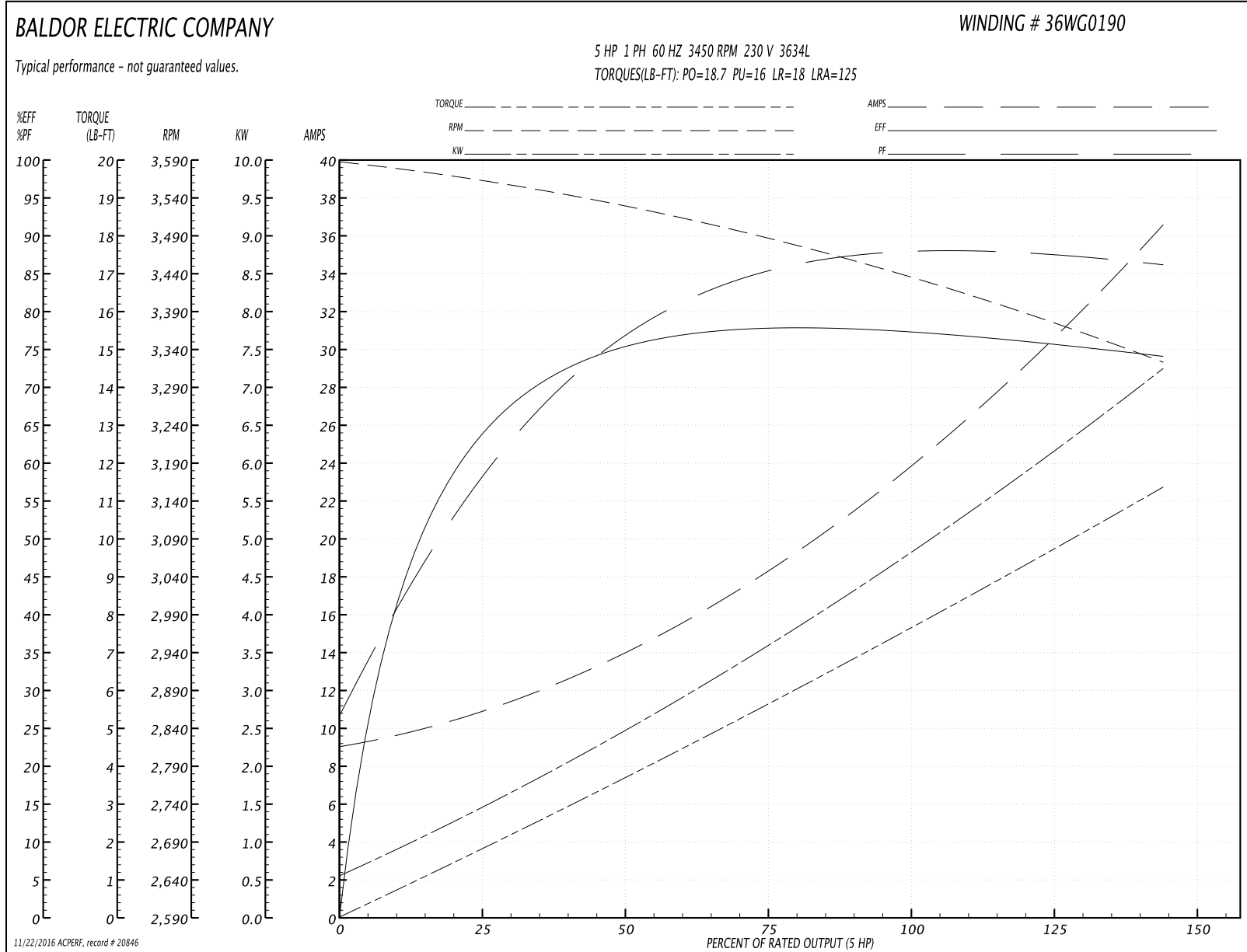

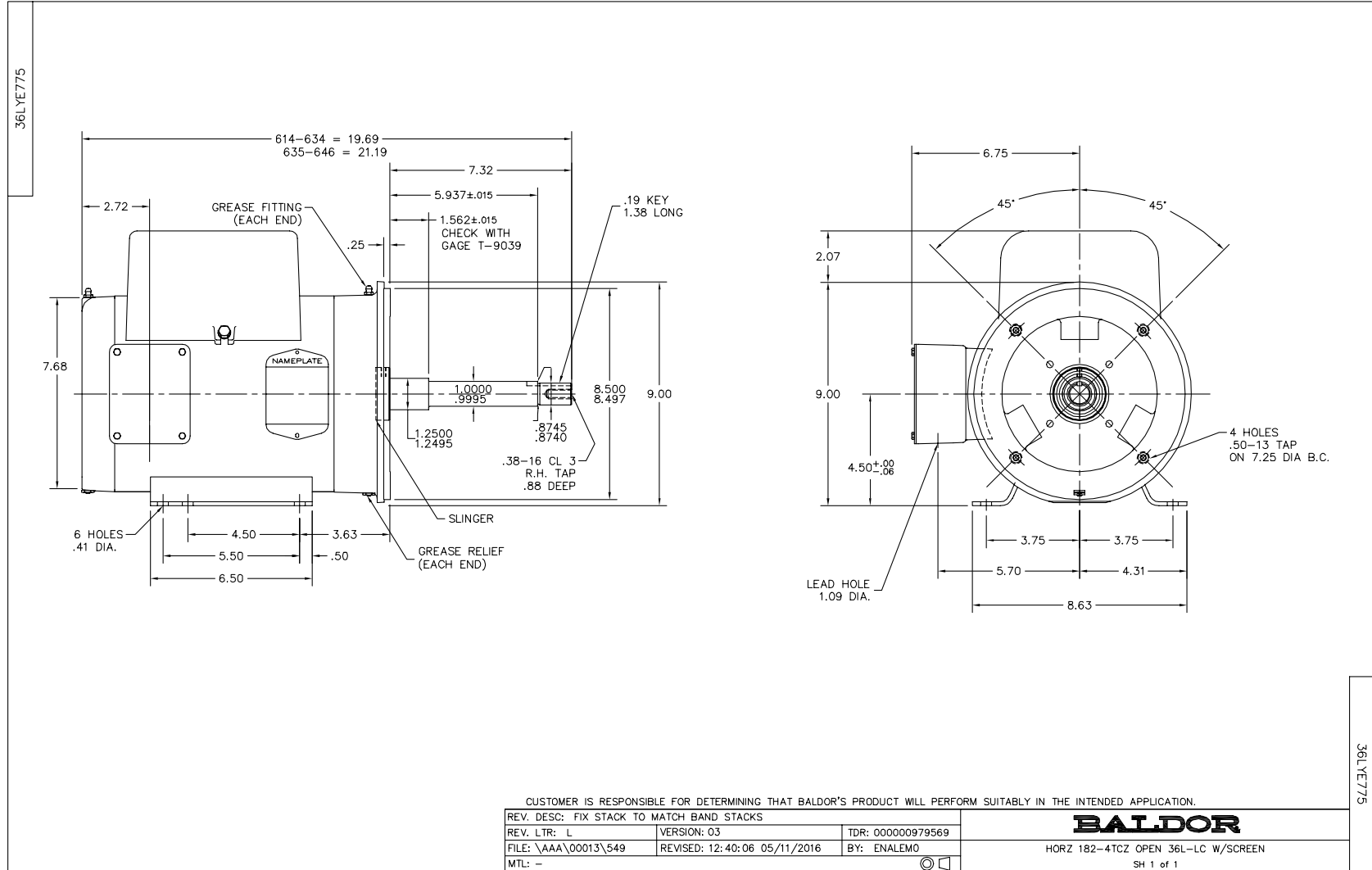

CD0017A01

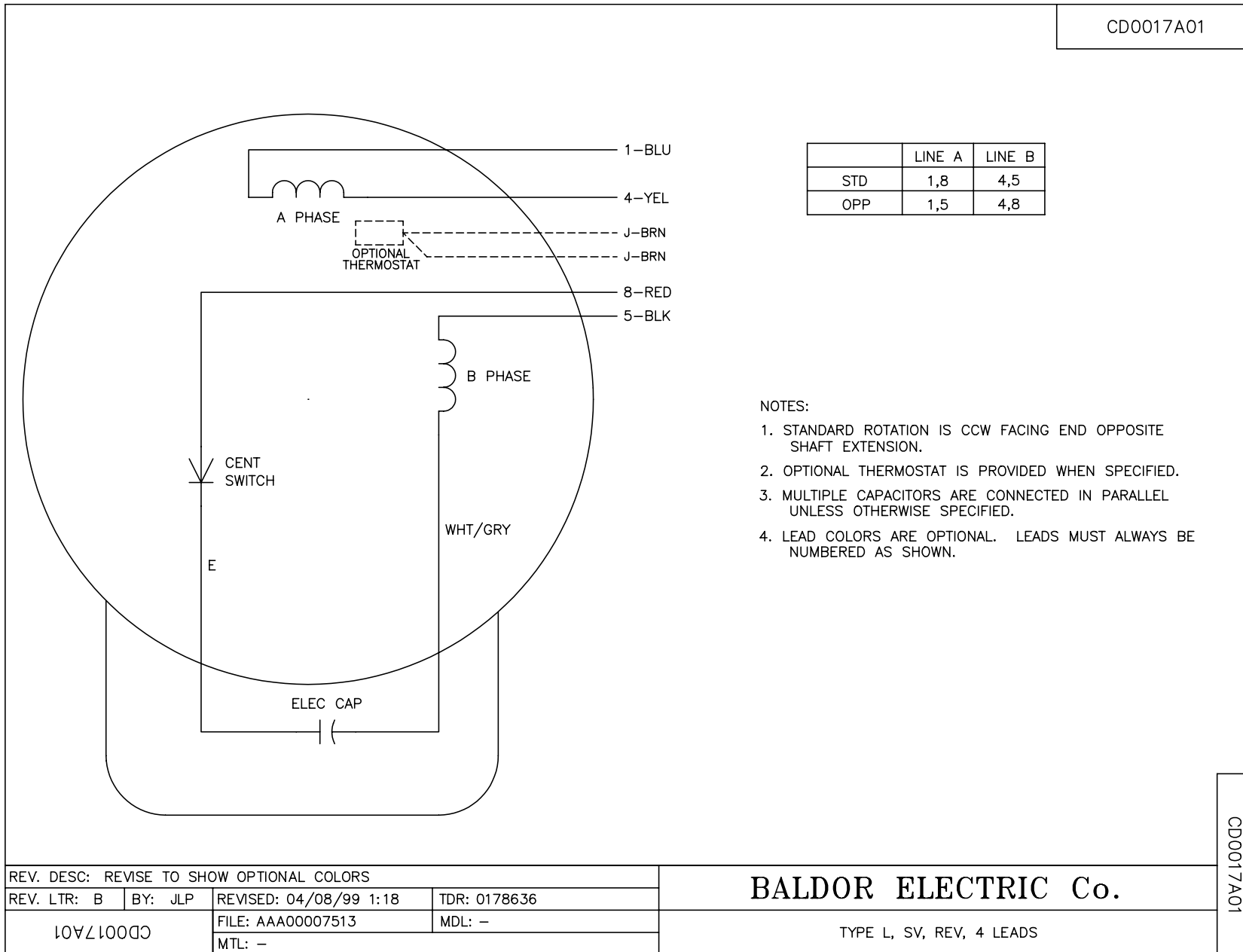

REV. DESC: REVISE TO SHOW OPTIONAL COLORS			
REV. LTR: B	BY: JLP	REVISED: 04/08/99 1:18	TDR: 0178636
CD0017A01		FILE: AAA00007513	MDL: -
		MTL: -	

**BALDOR ELECTRIC Co.**

TYPE L, SV, REV, 4 LEADS

CD0017A01