

# MAGNA3

Model E  
Circulator pumps



<b>1. Product description</b> . . . . .	<b>3</b>	<b>8. Operating the product</b> . . . . .	<b>54</b>
Applications . . . . .	3	Operating panel . . . . .	54
Application wizard . . . . .	3	Grundfos GO . . . . .	55
Characteristic features . . . . .	3	<b>9. Curve conditions</b> . . . . .	<b>56</b>
Benefits . . . . .	4	Performance curves . . . . .	56
Type key . . . . .	5	QR code on the pump nameplate . . . . .	56
Pump version . . . . .	5	Markings and approvals . . . . .	56
Pump heads in twin-head pumps . . . . .	5	<b>10. Performance curves and technical data</b> . . . . .	<b>57</b>
Performance range, MAGNA3 . . . . .	6	Conversion tables . . . . .	57
Performance range, MAGNA3 D single-head operation . . . . .	7	MAGNA3 32-60 F (N) . . . . .	58
Performance range, MAGNA3 D twin-head operation . . . . .	8	MAGNA3 32-100 F (N) . . . . .	59
<b>2. Product range</b> . . . . .	<b>9</b>	MAGNA3 32-120 F (N) . . . . .	60
Pump selection . . . . .	10	MAGNA3 40-80 F (N) . . . . .	61
<b>3. System applications</b> . . . . .	<b>12</b>	MAGNA3 40-120 F (N) . . . . .	62
Heating systems . . . . .	12	MAGNA3 40-180 F (N) . . . . .	63
Cooling systems . . . . .	15	MAGNA3 50-80 F (N) . . . . .	64
Ground source heat pump systems (GSHP) . . . . .	17	MAGNA3 50-120 F (N) . . . . .	65
Solar-heating systems . . . . .	17	MAGNA3 50-150 F (N) . . . . .	66
<b>4. Functions</b> . . . . .	<b>18</b>	MAGNA3 50-180 F (N) . . . . .	67
Control modes: Quick overview . . . . .	19	MAGNA3 65-120 F (N) . . . . .	68
Operating modes . . . . .	21	MAGNA3 65-150 F (N) . . . . .	69
Control modes . . . . .	21	MAGNA3 D 65-150 F . . . . .	70
Additional control mode features . . . . .	27	MAGNA3 80-100 F (N) . . . . .	71
Multipump modes . . . . .	28	MAGNA3 D 80-100 F . . . . .	72
Flow estimation accuracy . . . . .	29	MAGNA3 100-120 F (N) . . . . .	73
Readings on the pump . . . . .	29	MAGNA3 D 100-120 F . . . . .	74
Communication . . . . .	31	<b>11. Accessories</b> . . . . .	<b>75</b>
<b>5. Operating conditions</b> . . . . .	<b>41</b>	Insulating kits for applications with ice buildup . . . . .	75
General recommendations . . . . .	41	CIM modules available for MAGNA3 . . . . .	75
Pumped liquids . . . . .	43	Grundfos Remote Management . . . . .	76
Sound pressure level . . . . .	43	Grundfos GO Remote MI 301 . . . . .	76
Electrical data . . . . .	44	External Grundfos sensors . . . . .	77
<b>6. Construction</b> . . . . .	<b>45</b>	Cable for sensors . . . . .	79
Motor and electronic controller . . . . .	45	Blanking flange . . . . .	79
Differential-pressure and temperature sensor . . . . .	45	Pipe connections . . . . .	80
Pump connections . . . . .	45	<b>12. Product numbers</b> . . . . .	<b>81</b>
Surface treatment . . . . .	45	Single-head pumps . . . . .	81
Color . . . . .	45	Twin-head pumps . . . . .	82
Sectional drawing . . . . .	46	<b>13. Grundfos Product Center</b> . . . . .	<b>83</b>
Material specification . . . . .	46		
Sensor drawing . . . . .	48		
<b>7. Installation</b> . . . . .	<b>49</b>		
Minimum clearance . . . . .	49		
Mechanical installation . . . . .	50		
Electrical installation . . . . .	50		

## 1. Product description



TM082069

The Grundfos MAGNA3 circulator pumps are designed for circulating liquids in systems with variable flow requirements where you want to optimize the setting of the pump duty point, thus reducing energy costs.

### Applications

- Heating systems
  - main pump
  - mixing loops
  - heating surfaces
- air-conditioning and cooling systems
- domestic hot-water systems
- ground source heat-pump systems
- solar-heating systems.

The MAGNA3 circulator pump is perfect for both new systems as well as for replacement. The pump is ideal when operating in systems requiring an automated adjustment of pressure. This pump range is the best choice as it eliminates the need for expensive bypass valves and similar components.

Furthermore, the pump is appropriate for systems with hot-water priority as an external signal can immediately force the pump to operate according to the maximum curve, for example in solar-heating systems. When using the pumps in domestic hot-water systems, please observe local legislation regarding pump house material. Grundfos strongly recommends that you use stainless-steel pumps in domestic hot-water applications to avoid corrosion.

### Application wizard

MAGNA3 features a built-in application wizard, which is accessed via the pump's operating panel. By specifying your system step by step, the application wizard identifies the best suited control mode for your application.

See section Application wizard.

### Related information

[Application wizard](#)

### Duty range

Data	MAGNA3 (N) Single-head pumps	MAGNA3 D Twin-head pumps
Maximum flow rate	345 gpm (78.5 m <sup>3</sup> /h)	484 gpm (110 m <sup>3</sup> /h)
Maximum head	60 ft (18 m)	
Maximum system pressure	175 psi (1.2 MPa) (12 bar)	
Liquid temperature	14 to 230 °F (-10 to +110 °C)	

To ensure correct operation, it is important that the duty points in the system match the duty range of the pump.

### Characteristic features

- AUTOADAPT.
- FLOWLIMIT.
- FLOWADAPT - a combination of the AUTOADAPT control mode and FLOWLIMIT function.
- Built-in Grundfos differential-pressure and temperature sensor.
- Proportional-pressure control.
- Constant-pressure control.
- Constant-temperature control.
- Constant-curve duty.
- Maximum or minimum curve duty.
- Automatic night setback.
- Self-explanatory user interface with TFT display and high quality silicone push-buttons.
- Heat energy monitor.
- Wireless multipump function.
- The complete range is available for a maximum system pressure of 16 bar, PN 16.

## Benefits

- Low energy consumption due to the AUTOADAPT function, allowing the pump to adjust automatically to external factors, such as outside temperatures and consumption patterns.
- Simple installation.
- No maintenance and long life.
- Operating log history.
- Easy and simple system optimisation.
- External control and monitoring enabled via add-on modules.
- No external motor protection required.
- Insulating shells for heating systems supplied with single-head pumps.
- Wide temperature range due to thermal separation of the control box and pump media.
- MAGNA pumps are preferred and used in MIXIT solution system.

## Type key

Example: **MAGNA3 80-100 F N 360**

Example: **MAGNA3 D 80-100 F 360**

Code	Explanation
<b>MAGNA3</b>	Type range
	Single-head pump
<b>D</b>	Twin-head pump
<b>80-</b>	Nominal diameter (DN) of inlet and outlet ports [mm]
<b>100</b>	Maximum head [dm]
<b>F</b>	Flanged (pipe connection type)
	Cast iron (pump housing material)
<b>N</b>	Stainless steel (pump housing material)
<b>360</b>	Port-to-port length [mm]

## Pump version

This data booklet is valid for MAGNA3 Model E single-head and MAGNA3 D Model E twin-head pumps. Model E indicates the pump version. The pump version is stated on the nameplate.

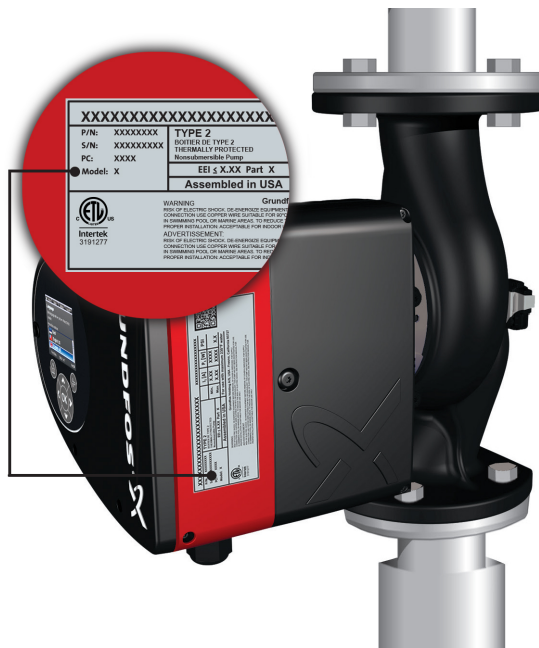

TM067734

Location of the pump version on the nameplate

## Pump heads in twin-head pumps

The twin-head pump housing has a flap valve on the outlet side. The flap valve seals off the port of the idle pump housing to prevent the pumped liquid from running back to the inlet side.



TM061565

Twin-head pump housing with flap valve

Due to the flap valve, there is a difference in the hydraulics between the two pump heads.

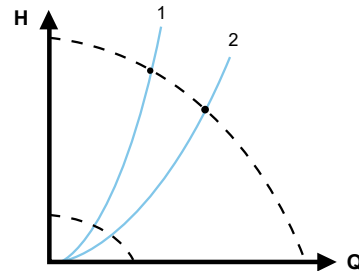

TM061566

Hydraulic difference between the pump head to the right (1) and to the left (2) of the flap valve

### Performance range, MAGNA3

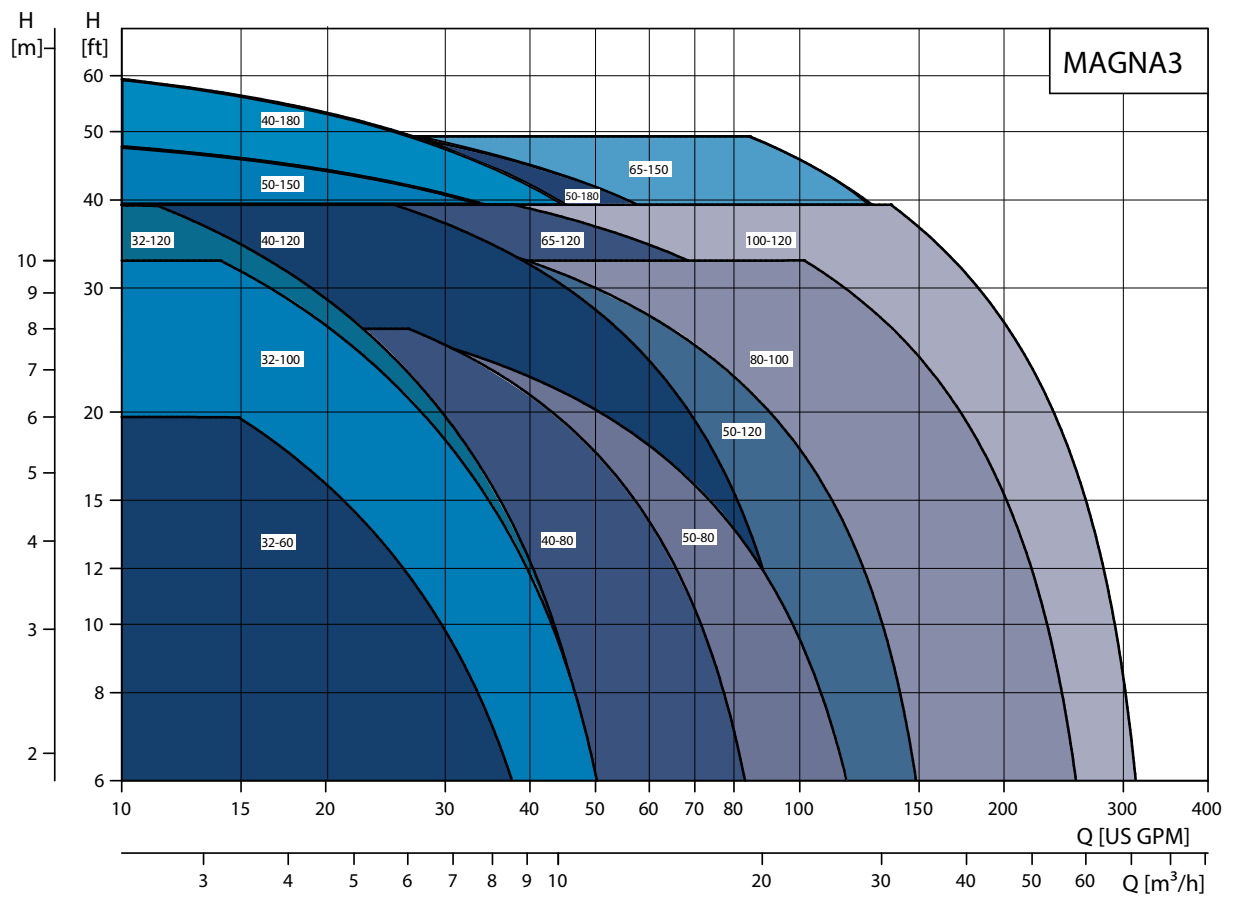

TM057654

Performance range for MAGNA3 single-head pump

Performance range, MAGNA3 D single-head operation

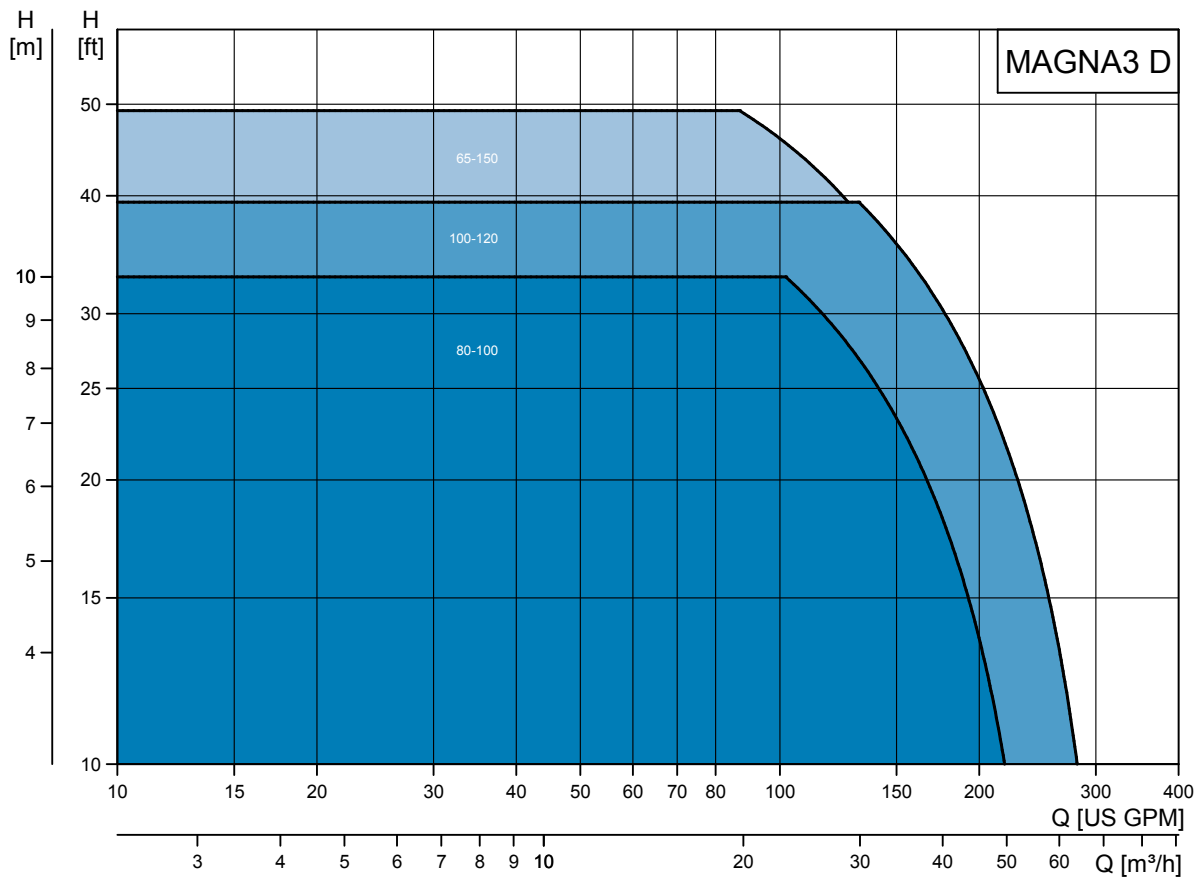

TM057655

Performance range for MAGNA3 D twin-head pump in single-head operation

### Performance range, MAGNA3 D twin-head operation

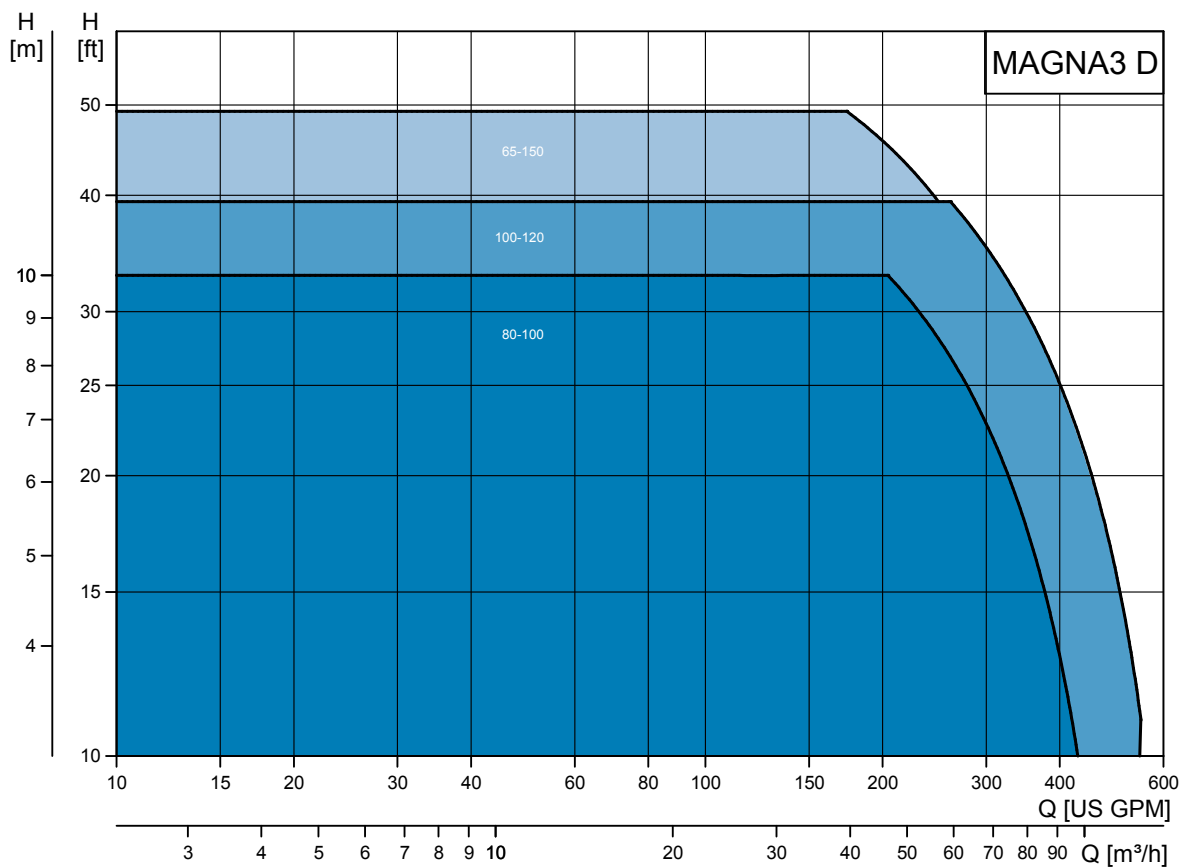

TM057656

Performance range for MAGNA3 D twin-head pump in twin-head operation

## 2. Product range

### Single-head pumps

Pump type	Port-to-port length [in. (mm)]	Cast iron		Stainless steel (N)		Section reference
		115 V	230 V	115 V	230 V	
MAGNA3 32-60 F (N)	6 - 1/2 (165)	•	•	•	•	<a href="#">MAGNA3 32-60 F (N)</a>
MAGNA3 32-100 F (N)	6 - 1/2 (165)	•	•	•	•	<a href="#">MAGNA3 32-100 F (N)</a>
MAGNA3 32-120 F (N)	6 - 1/2 (165)	•	•	•	•	<a href="#">MAGNA3 32-120 F (N)</a>
MAGNA3 40-80 F (N)	8 - 9/16 (216)	•	•	•	•	<a href="#">MAGNA3 40-80 F (N)</a>
MAGNA3 40-120 F (N)	8 - 9/16 (216)	•	•	•	•	<a href="#">MAGNA3 40-120 F (N)</a>
MAGNA3 40-180 F (N)	8 - 9/16 (216)	•	•	•	•	<a href="#">MAGNA3 40-180 F (N)</a>
MAGNA3 50-80 F (N)	9 - 1/2 (240)	•	•	•	•	<a href="#">MAGNA3 50-80 F (N)</a>
MAGNA3 50-120 F (N)	11 - 1/16 (280)	•	•	•	•	<a href="#">MAGNA3 50-120 F (N)</a>
MAGNA3 50-150 F (N)	11 - 1/16 (280)	•	•	•	•	<a href="#">MAGNA3 50-150 F (N)</a>
MAGNA3 50-180 F (N)	11 - 1/16 (280)	•	•	•	•	<a href="#">MAGNA3 50-180 F (N)</a>
MAGNA3 65-120 F (N)	13 - 7/16 (340)	•	•	•	•	<a href="#">MAGNA3 65-120 F (N)</a>
MAGNA3 65-150 F (N)	13 - 7/16 (340)		•		•	<a href="#">MAGNA3 65-150 F (N)</a>
MAGNA3 80-100 F (N)	14 - 3/16 (360)		•		•	<a href="#">MAGNA3 80-100 F (N)</a>
MAGNA3 100-120 F (N)	17 - 3/4 (450)		•		•	<a href="#">MAGNA3 100-120 F (N)</a>

### Twin-head pumps

Pump type	Port-to-port length [in. (mm)]	Cast iron		Stainless steel (N)		Section reference
		115 V	230 V	115 V	230 V	
MAGNA3 D 65-150 F			•			<a href="#">MAGNA3 D 65-150 F</a>
MAGNA3 D 80-100 F			•			<a href="#">MAGNA3 D 80-100 F</a>
MAGNA3 D 100-120 F			•			<a href="#">MAGNA3 D 100-120 F</a>

## Pump selection

All pumps have a "best point" ( $\eta_{\max}$ ), indicating where the pump is working most efficiently.

Consider the parameters in the following section.

### Pump size

The system characteristic is used together with the performance curve of the pump for sizing and correct pump selection.

The selection of pump size must be based on the following:

- required maximum flow
- maximum pressure loss in the system.

Refer to the system characteristics to determine the duty point.

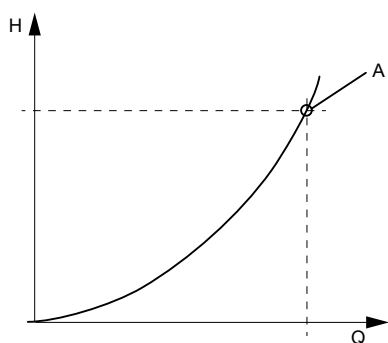

TM022040

*System characteristic*

Pos.	Description
A	Duty point

## Operating conditions

You must check whether the operating conditions are fulfilled, i.e.:

- liquid quality and temperature
- ambient conditions
- minimum inlet pressure
- maximum operating pressure.

See section General recommendations.

### Related information

[General recommendations](#)

## Control modes

- AUTOADAPT (factory setting) which is suitable for most installations.
- FLOWADAPT in systems where flow limitation is required.
- Proportional-pressure control in systems with considerable pressure losses in relation to large flow variations.
- Constant-pressure control in systems with insignificant pressure losses in relation to large flow variations.
- Constant-temperature control in systems with a fixed system characteristic, for example domestic hot-water systems.
- Differential-temperature control in heating and cooling systems.
- Constant flow in systems where a constant flow is required independently of the head.
- Constant-curve duty.

For further information on control and operating modes, see section Functions.

### Automatic determination of the setpoint

If you know the duty point, you can enter the value on the display when setting the pump. The pump then automatically calculates the corresponding setpoint. See the figures below.

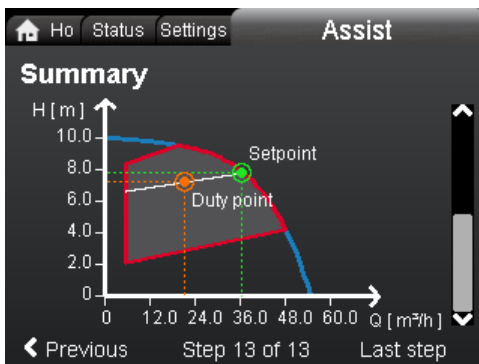
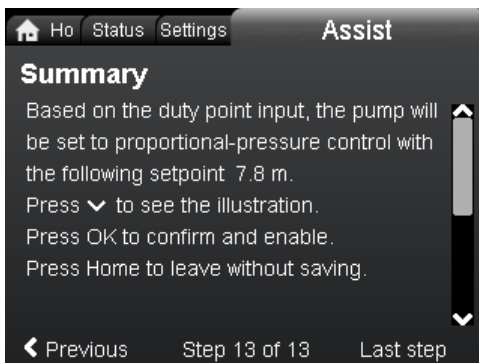

Example of setpoint calculation based on a chosen control mode and entered Q and H values

## Related information

### 4. Functions

## Communication

The Grundfos Communication Interface Modules (CIM) enable the MAGNA3 to connect to standard fieldbus networks, offering substantial benefits:

- complete process control and monitoring
- modular design, prepared for future requirements
- based on standard functional profiles
- simple configuration and easy installation
- open communication standards
- reading warning and alarm indications.

For further details, see the section Communication interface modules (CIM).

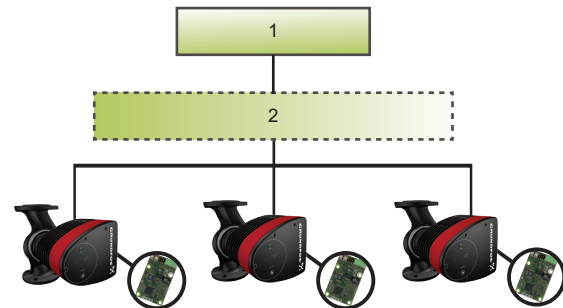

Example of typical building management system, BMS (1) with pumps connected in parallel. The gateway (2) facilitates the transfer of data between two different networks based on different communication protocols.

## Related information

### Communication interface modules, CIM

## 3. System applications

### Heating systems

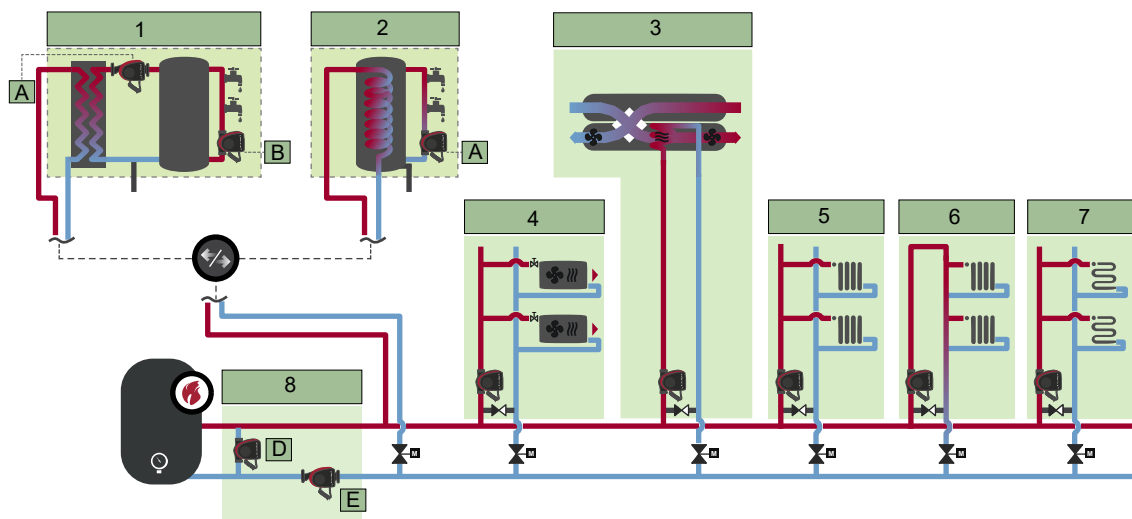

TM070360

Functional drawing of a heating system in a commercial building

Pos.	Description
1	Hot water
1A	Charging pump
1B	Recirculation
2	Hot water
2A	Recirculation
3	Air handling unit
4	Fan coil unit
5	Radiator two-pipe system
6	Radiator one-pipe system
7	Underfloor/ceiling
8	Boiler pump
8D	Shunt/buffer
8E	'Primary only' system

The following sections provide recommendations on which control mode to choose according to your application and where the pump is placed in the system.

In addition, you can use MAGNA3's built-in application wizard to help you identify which control mode is best suited your application. See section Application wizard.

#### Related information

[Application wizard](#)

#### 1A. Hot water, charging pump

Hot-water applications often have an external controller, which starts the pump when the temperature falls below a desired setpoint. The pump will run until the temperature in the tank is back up.

If the design flow is known, it can be set directly on the pump. The suitable control mode is constant flow.

If only the desired differential temperature across the plate heat exchanger is known, constant speed curves can be chosen and adjusted to reach the desired delta T.

See sections Constant flow and Constant curve.

#### Related information

[Constant flow](#)

[Constant curve](#)

#### 1B. Hot water, recirculation

The constant-temperature control mode together with the pump's internal temperature sensor makes it possible to maintain any given temperature of the return water. The desired temperature setpoint is set directly on the pump.

If you want to maintain a certain temperature at a critical point furthest out in the system, the constant-temperature control mode can be used in combination with an external temperature sensor.

See section Constant temperature.

#### Related information

[Constant temperature](#)

## 2A. Hot water, recirculation

See section 1B. Hot water, recirculation.

### Related information

[1B. Hot water, recirculation](#)

## 3. Air handling unit

### Constant flow

If the air flow temperature and thereby the heat output is controlled by for example a motorised valve, the system is typically operating with constant flow. Therefore, we recommend that the pump operates in the constant-flow control mode.

See sections Constant flow and Constant curve.

### Related information

[Constant curve](#)

### Variable flow

Normally, the distance between the pump and the air handling unit is short, eliminating pressure losses almost completely even if the flow varies. Therefore, the constant-pressure control mode is suitable in this type of application.

See section Constant pressure.

### Related information

[Constant pressure](#)

## 4. Fan coil unit

Typically, fan coil units are situated at a considerable distance from the pump.

Therefore, depending on how many fan coils are operating and at which demand, large variations in pressure loss will occur.

In such applications proportional pressure is the recommended control mode.

If the pressure losses are unknown, you can choose the AUTOADAPT control mode, which will automatically adjust the pump performance to the actual system characteristic.

See sections Proportional pressure and AUTOADAPT.

### Related information

[Proportional pressure](#)

[AUTOADAPT](#)

## 5. Radiator, two pipe

Since these applications have varying pressure losses due to the distance between the pump and radiators, we recommend that the pump operates in the proportional-pressure control mode.

If the pressure losses are unknown, it is possible to use the AUTOADAPT control mode, which will automatically adjust the pump performance to the actual system characteristic.

See sections Proportional pressure and AUTOADAPT.

### Related information

[Proportional pressure](#)

[AUTOADAPT](#)

## 6. Radiator, one pipe

In one-pipe radiator systems the flow is typically constant, making the pressure losses constant as well. Therefore, pumps in these applications are best suited to operate in constant-pressure control mode.

Because these applications are often designed with a specific differential temperature, it is possible to adjust the constant-pressure setpoint until this differential temperature is achieved.

See section Constant pressure.

### Related information

[Constant pressure](#)

## 7. Underfloor/ceiling

In these systems the flow will vary depending on how many rooms are in operation. However, since the distance is short between the pump and manifold, to which the pipes are connected, there is no variation in pressure losses. Because of this the constant-pressure control mode is the optimum choice.

See section Constant pressure.

### Related information

[Constant pressure](#)

## 8D. Shunt/buffer

### Constant temperature with internal sensor

If both the return temperature and the desired minimum temperature back to the boiler are known, you can calculate the required flow temperature supplied by the shunt pump.

The calculated flow temperature is set directly on the pump, when setting the control mode to constant temperature.

See section Constant temperature,

#### Related information

[Constant temperature](#)

### Constant temperature with external sensor

The minimum required return temperature back to the boiler can be measured and controlled by the use of an external temperature sensor placed close to the boiler. This temperature can then be set directly on the pump together with the constant-temperature control mode.

See section Constant temperature,

#### Related information

[Constant temperature](#)

### Constant differential temperature

If the purpose of the boiler shunt pump is to secure that a maximum differential temperature across a boiler is not exceeded, choose the differential temperature control mode. Despite load variations, the differential temperature is then kept on a desired level. This requires an additional temperature sensor.

## 8E. 'Primary only' system

These pumps are characterised by operating with large variations in flow. Depending on the distance between the pump and the last branch served by the pump, either constant-pressure or proportional-pressure control modes can be chosen.

Typically, proportional pressure will be the better option if the pressure is above 5 m or the distance between the pump and the last branch exceeds 10 m.

On the other hand, if pressure loss variations are limited because all branches are connected closer to the pump, constant pressure will be the recommended control mode.

See sections Proportional pressure and Constant pressure.

#### Related information

[Constant pressure](#)

[Proportional pressure](#)

## Cooling systems

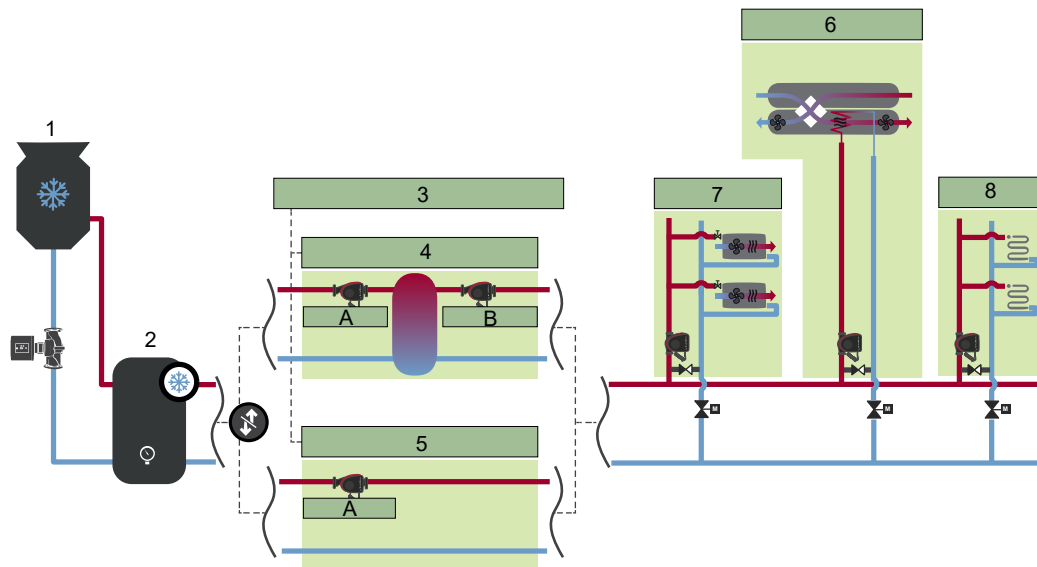

TM070358

Functional drawing of a cooling system in a commercial building

Pos.	Description
1	Cooling tower
2	Cooling source
3	Chiller pump
4	Primary/secondary system
4A	Primary pump
4B	Secondary pump
5	"Primary only" system
5A	Primary pump
6	Air handling unit
7	Fan coil unit
8	Underfloor/ceiling

The following sections provide recommendations on which control mode to choose according to your application and where the pump is placed in the system.

In addition, you can use MAGNA3's built-in application wizard to help you identify which control mode is best suited your application. See section Application wizard.

### Related information

[Application wizard](#)

### 4A. Primary/secondary system, primary pump

#### Constant temperature

If the setpoint temperature from the chiller is known and the aim is to maintain this temperature all the way to the buffer tank, the constant-temperature control mode can be chosen. Depending on the position of the pump, the internal or an external temperature sensor can be used to measure the temperature.

See section Constant temperature.

#### Related information

[Constant temperature](#)

#### Differential temperature

If the design differential temperature across the chiller is known, the differential temperature control mode can be selected. This requires an additional temperature sensor.

See section Differential temperature.

#### Related information

[Differential temperature](#)

#### Constant flow

In cases where the chiller is not varying, the pump is typically started and stopped by the chiller. This indicates a requirement for constant flow, hence this being the optimum control mode.

See sections Constant flow and Constant curve.

#### Related information

[Constant curve](#)

[Constant flow](#)

## Constant curve

In cases where the chiller is not varying and the required delta-T is known, the constant-curve control mode can be used. Here, the constant curve is adjusted until the desired delta-T is obtained.

See section Constant curve.

### Related information

[Constant curve](#)

## 4B. Primary/secondary system, secondary pump

Secondary pumps are exposed to large variations in flow and pressure losses due to load variations in the system. For this reason, proportional pressure is the recommended control mode.

If the pressure losses are below 5 mWc, the constant pressure control mode is a good alternative.

If the pressure losses are unknown, you can choose the AUTOADAPT control mode, which will automatically adjust the pump performance to the actual system characteristic.

See sections Proportional pressure, Constant pressure, and AUTOADAPT.

### Related information

[Constant pressure](#)

[Proportional pressure](#)

[AUTOADAPT](#)

## 5A. 'Primary only' system, primary pump

These pumps are exposed to large variations in flow and pressure losses due to load variations in the system. For this reason, proportional pressure is the recommended control mode.

If the pressure losses are below 5 mWc, the constant-pressure control mode is a good alternative.

If the pressure losses are unknown, you can choose the AUTOADAPT control mode, which will automatically adjust the pump performance to the actual system characteristic.

See sections Proportional pressure, Constant pressure, and AUTOADAPT.

### Related information

[Constant pressure](#)

[Proportional pressure](#)

[AUTOADAPT](#)

## 6. Air handling unit

If the required flow in the coil is known, constant flow is the preferred control mode. Here, the pump will adjust to the needed pressure.

The actual heat supply is controlled by the motorised valves as shown in section Cooling systems.

If the pressure loss in the coil is known, constant pressure is a suitable control mode. This control mode ensures that the pump is able to overcome the pressure loss.

See sections Constant curve, Constant flow, and Constant pressure.

### Related information

[Cooling systems](#)

[Constant curve](#)

[Constant pressure](#)

[Constant flow](#)

## 7. Fan coil unit

Fan coil applications are characterised by variable flow due to a varying number of coils in operation. The more coils in operation the higher the pressure loss.

Therefore, proportional pressure is the optimum control mode.

See section Proportional pressure.

### Related information

[Proportional pressure](#)

## 8. Underfloor/ceiling

In an underfloor/ceiling application the circuits are individually balanced according to pressure loss. This means that all circuits have the same pressure loss even though they may differ in length.

Even if the flow varies, the pressure loss will remain the same, and for this reason constant pressure is the recommended control mode.

See section Constant pressure.

### Related information

[Constant pressure](#)

## Ground source heat pump systems (GSHP)

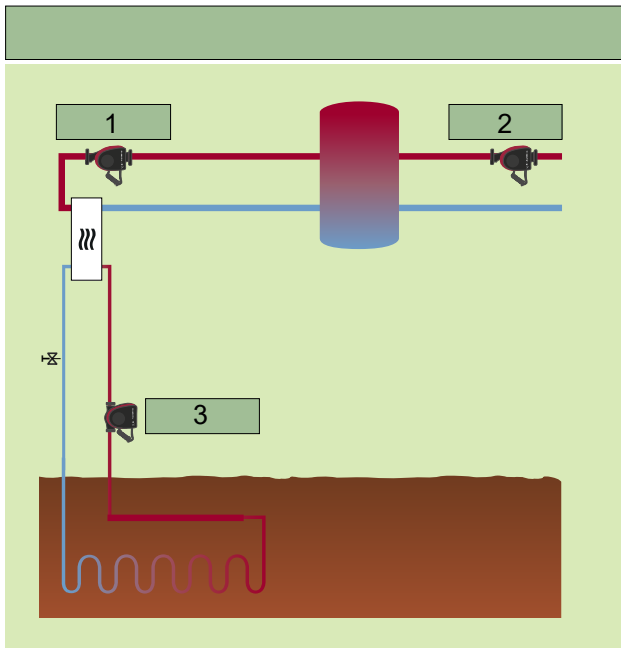

TM070359

Ground source heat pump system in a commercial building

Pos.	Description
1	Charging pump
2	Distribution side
3	Ground loop

The following sections provide recommendations on which control mode to choose according to your application and where the pump is placed in the system.

In addition, you can use MAGNA3's built-in application wizard to help you identify which control mode is best suited your application. See section Application wizard.

### Related information

[Application wizard](#)

### 1. Charging pump

If the temperature in the tank falls below a certain threshold, the charging pump starts. The pump operates until the tank temperature is back up at the desired level.

As this is a closed circuit with no flow variations, constant-flow or constant-curve operation are suitable control modes. See sections Constant flow and Constant curve.

### Related information

[Constant flow](#)

[Constant curve](#)

### 2. Distribution side

If the distribution pump is connected to a radiator system, proportional pressure is the optimum control mode. If underfloor heating is connected right after the pump, constant pressure is preferred.

See sections Proportional pressure and Constant pressure.

### Related information

[Constant pressure](#)

[Proportional pressure](#)

### 3. Ground loop

Since the ground loop is a closed system with no variations in flow, the most suitable control modes are constant flow and constant curve.

See sections Constant flow and Constant curve.

### Related information

[Constant flow](#)

[Constant curve](#)

## Solar-heating systems

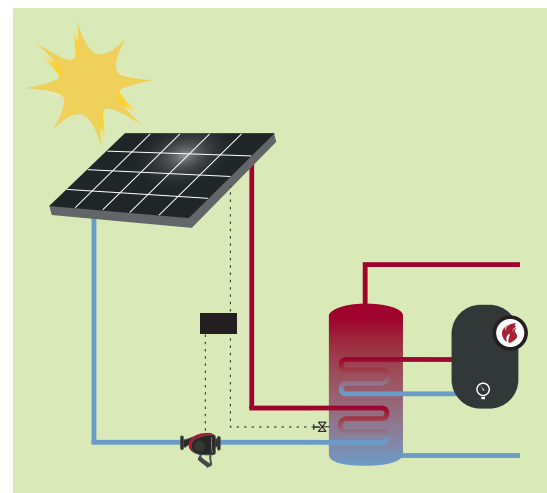

TM070367

Functional drawing of a solar-heating system

We recommend that the main pump in a solar-heating system operates with the constant-curve control mode or as recommended by the solar system provider.

Alternative control modes, like constant temperature or differential temperature, can be viable options, but the must only be chosen based on dialogue with the solar system provider.

See sections Constant curve, Constant temperature, and Differential temperature.

### Related information

[Constant curve](#)

[Constant temperature](#)

[Differential temperature](#)

## 4. Functions

	Section
<b>Operating modes</b>	
Normal (control modes enabled)	<i>Normal</i>
Stop	<i>Stop</i>
Minimum curve	<i>Min.</i>
Maximum curve	<i>Max.</i>
<b>Control modes</b>	
AUTOADAPT (factory setting)	<i>AUTOADAPT</i>
FLOWADAPT	<i>FLOWADAPT</i>
Proportional pressure	<i>Proportional pressure</i>
Constant pressure	<i>Constant pressure</i>
Constant temperature	<i>Constant temperature</i>
Differential temperature	<i>Differential temperature</i>
Constant flow	<i>Constant flow</i>
Constant curve	<i>Constant curve</i>
<b>Additional control mode features</b>	
FLOW <sub>LIMIT</sub>	<i>FLOWLIMIT</i>
<b>Automatic Night Setback</b>	<i>Automatic night setback</i>
<b>Multipump modes</b>	
Alternating operation	<i>Multipump function</i>
Backup operation	<i>Backup operation</i>
Cascade operation	<i>Cascade operation</i>
<b>Readings and settings on the pump</b>	
Operating panel and display	<i>Performance overview</i>
<b>Operating status</b>	<i>Operating status and pump performance</i>
<b>Pump performance</b>	<i>Operating status and pump performance</i>
<b>Warning and alarm</b>	
Heat energy monitor	<i>Heat energy monitor</i>
<b>Operating log</b>	
Grundfos Eye (status indicator)	<i>Grundfos Eye</i>
<b>Communication</b>	
Wireless Grundfos GO	<i>Grundfos GO Remote</i>
Wireless GENIair connection	<i>Wireless GENIair</i>
Pump information to BMS via CIM modules	<i>CIM modules</i>
Bus via GENIbus	<i>Functions</i>
Bus via LonWorks	<i>Available CIM modules</i>
Bus via PROFIBUS DP	<i>Available CIM modules</i>
Bus via Modbus RTU	<i>Available CIM modules</i>
Bus via BACnet MS/TP	<i>Available CIM modules</i>
Digital inputs	<i>Digital inputs</i>
Relay outputs	<i>Relay outputs</i>
Analog input for external sensor	<i>Analog input for an external sensor</i>
External setpoint function	<i>External control system</i>

## Control modes: Quick overview

### AUTOADAPT

- We recommend this control mode for most heating systems.
- During operation, the pump automatically makes the necessary adjustment to the actual system characteristic.

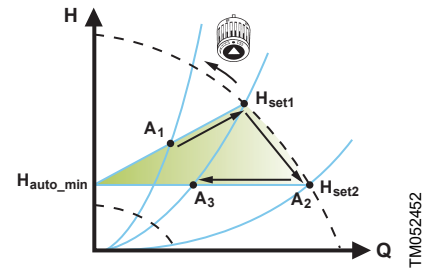

### FLOWADAPT

The FLOWADAPT control mode combines a control mode and a function:

- The pump is running in AUTOADAPT.
- The delivered flow from the pump will never exceed a selected  $FLOW_{LIMIT}$ .

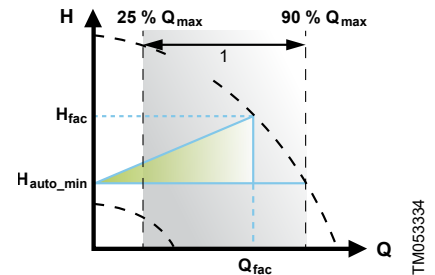

### Proportional pressure

- Used in systems with relatively large pressure losses in the distribution pipes.
- The head of the pump will increase proportionally to the flow in the system to compensate for the large pressure losses in the distribution pipes.

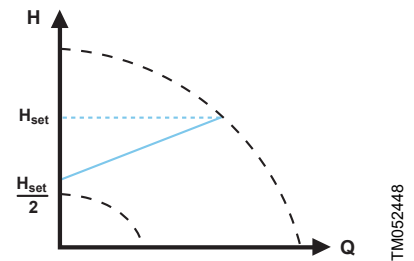

### Constant pressure

- We recommend this control mode in systems with relatively small pressure losses.
- The pump head is kept constant, independent of the flow in the system.

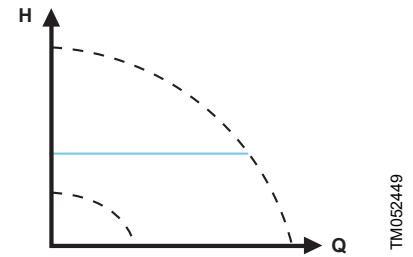

### Constant temperature

In systems with a fixed system characteristic, for example domestic hot-water systems, the control of the pump according to a constant return-pipe temperature is relevant.

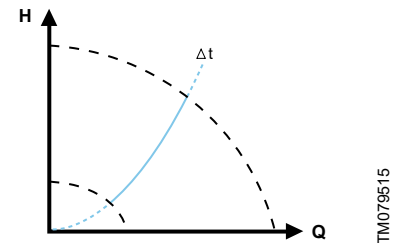

**Differential temperature**

- Ensures a constant differential temperature drop across heating and cooling systems.
- The pump will maintain a constant differential temperature between the pump and the external sensor.

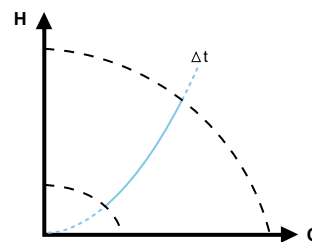

TM079515

**Constant flow**

**Note:** Available for pumps with production code from 1838.

- The pump maintains a constant flow in the system independently of the head.
- It is not possible to use an external sensor, instead, the pump uses its internal sensor.

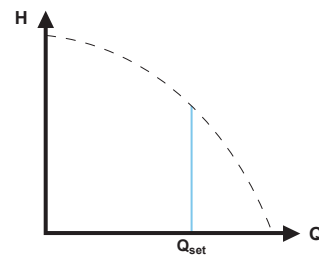

TM071240

**Constant curve**

- The pump can be set to operate according to a constant curve, like an uncontrolled pump.
- Set the desired speed in % of the maximum speed in the range from minimum to 100 %.

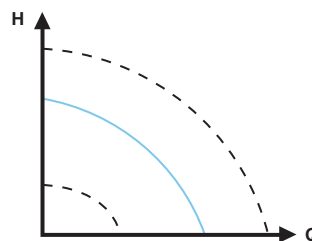

TM052446

For multipump modes, see the table in the Function section.

**Related information**[4. Functions](#)

## Operating modes

### Normal

The pump runs according to the selected control mode.

**Note:** You can select the control mode and setpoint even if the pump is not running in **Normal** mode.

### Stop

The pump stops.

### Min.

You can use the minimum curve mode in periods where a minimum flow rate is required.

This operating mode is for instance suitable for manual night setback if automatic night setback is not desired.

The minimum curve can be adjusted by defining the pump's operating range.

### Max.

You can use the maximum curve mode in periods where a maximum flow rate is required.

This operating mode is for instance suitable for hot-water priority.

You can select the normal, stop, min. and max. operating modes directly by use of the built-in digital inputs. See section Connection to power supply, terminal-connected versions.

The maximum curve can be adjusted by defining the pump's operating range.

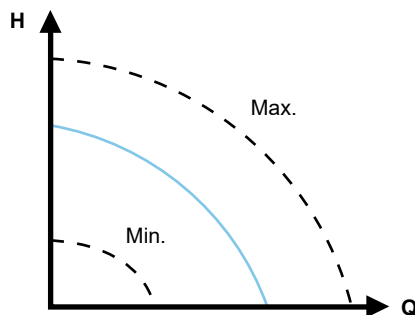

Maximum and minimum curves

### Related information

[Connection to power supply, terminal-connected versions](#)

## Control modes

### Factory setting

The pumps have been factory-set to AUTOADAPT without automatic night setback, which is suitable for most installations.

The setpoint has been factory-set.

### AUTOADAPT

We recommend the AUTOADAPT control mode for most heating systems, especially in systems with relatively large pressure losses in the distribution pipes, and in replacement situations where the proportional-pressure duty point is unknown.

This control mode has been developed specifically for heating systems and we do not recommend it for air-conditioning and cooling systems.

### Characteristics and key benefits

- Automatically adjusts the pump to actual system characteristics.
- Ensures minimum energy consumption and a low noise level.
- Reduced operating costs and increased comfort .

### Technical specifications

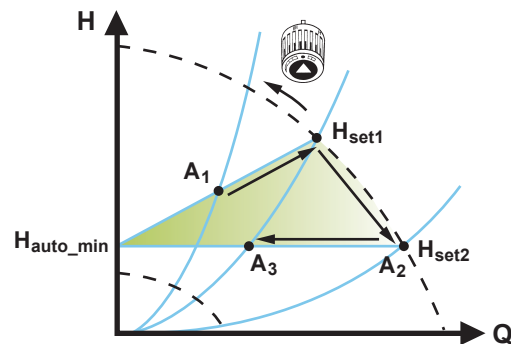

AUTOADAPT control

A <sub>1</sub> :	Original duty point
A <sub>2</sub> :	Lower registered head on the max. curve
A <sub>3</sub> :	New duty point after AUTOADAPT control
H <sub>set1</sub> :	Original setpoint
H <sub>set2</sub> :	New setpoint after AUTOADAPT control
H <sub>auto_min</sub> :	A fixed value of 1.5 m

The AUTOADAPT control mode is a form of proportional-pressure control where the control curves have a fixed origin,  $H_{\text{auto\_min}}$ .

When you have enabled AUTOADAPT, the pump will start with the factory setting,  $H_{\text{fac}} = H_{\text{set1}}$ , corresponding to approximately 55 % of its maximum head, and then adjust its performance to  $A_1$ . See the figure above.

When the pump registers a lower head on the maximum curve,  $A_2$ , the AUTOADAPT function automatically selects a correspondingly lower control curve,  $H_{\text{set2}}$ . If the valves in the system close, the pump adjusts its performance to  $A_3$ . See the figure above.

**Note:** Manual setting of the setpoint is not possible.

### Related information

[Performance overview](#)

## FLOWADAPT

The FLOWADAPT control mode combines AUTOADAPT and FLOWLIMIT, meaning that the pump runs AUTOADAPT while at the same time ensuring that the flow rate never exceeds the entered FLOWLIMIT value. This control mode is suitable for systems where a maximum flow limit is desired and where a steady flow through the boiler in a boiler system is required. Here, no extra energy is used for pumping too much liquid into the system.

In systems with mixing loops, you can use FLOWADAPT to control the flow in each loop.

### Characteristics and key benefits

- The dimensioned flow for each zone (required heat energy) is determined by the flow from the pump. This flow rate can be set precisely in the FLOWADAPT control mode without using throttling valves.
- When the flow rate is set lower than the balancing valve setting, the pump will ramp down instead of losing energy by pumping against a balancing valve.
- Cooling surfaces in air-conditioning systems can operate at high pressure and low flow rate.

**Note:** The pump cannot reduce the flow rate on the inlet side, but is able to control that the flow rate on the outlet side is at least the same as on the inlet side, as the pump has no built-in valve.

## Technical specifications

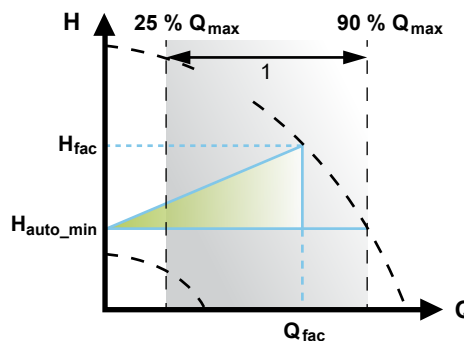

TM053334

### FLOWADAPT control

Pos.	Description
1	Setting range

The factory setting of the FLOWADAPT is the flow rate where the AUTOADAPT factory setting meets the maximum curve. See the figure above.

The typical pump selection is based on the required flow rate and calculated pressure losses. The pump is typically oversized by 30 to 40 % to ensure that it can overcome the pressure losses in the system. Under these conditions, the full benefit of AUTOADAPT cannot be obtained.

To adjust the maximum flow rate of this "oversized" pump, balancing valves are built into the circuit to increase the resistance and thus reduce the flow rate.

The FLOWADAPT function reduces the need for a pump throttling valve, see the figure below, but does not eliminate the need for balancing valves in heating systems.

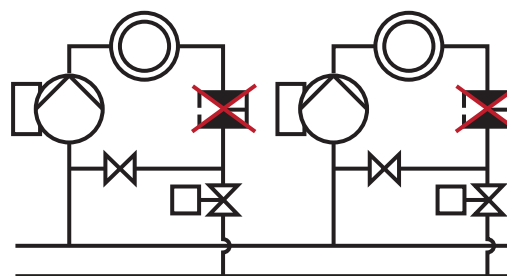

TM052685

Reduced need for a pump throttling valve

## Proportional pressure

Proportional pressure is suitable in systems with relatively large pressure losses in the distribution pipes and in air-conditioning and cooling systems:

- Two-pipe heating systems with thermostatic valves and the following:
  - very long distribution pipes
  - strongly throttled pipe balancing valves
  - differential-pressure regulators
  - large pressure losses in the parts of the system through which the entire amount of water flows, for example a boiler, heat exchanger and distribution pipe up to the first branching.
- Primary circuit pumps in systems with large pressure losses in the primary circuit.
- Air-conditioning systems with the following:
  - heat exchangers (fan coils)
  - cooling ceilings
  - cooling surfaces.

## Characteristics and key benefits

- The head of the pump increases proportionally to the flow rate in the system.
- Compensates for large pressure losses in the distribution pipes.

## Technical specifications

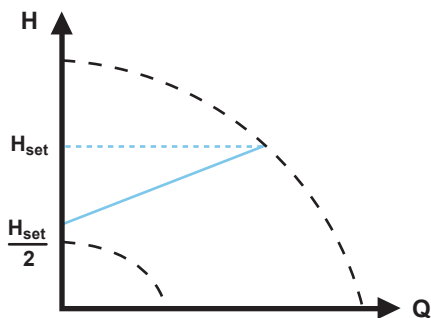

TM052448

### Proportional-pressure control

The head against a closed valve is half the setpoint  $H_{set}$ .

## Constant pressure

A constant pressure is advantageous in systems with relatively small pressure losses in the distribution pipes:

- Two-pipe heating systems with thermostatic valves:
  - dimensioned for natural circulation
  - small pressure losses in the parts of the system through which the entire amount of water flows, for example a boiler, heat exchanger and distribution pipe up to the first branching.
  - modified to a high differential temperature between the flow pipe and the return pipe (for example district heating).
- Underfloor heating systems with thermostatic valves.
- One-pipe heating systems with thermostatic valves or pipe balancing valves.
- Primary circuit pumps in systems with small pressure losses in the primary circuit.

## Characteristics and key benefits

- The pump pressure is kept constant, independent of the flow in the system.

## Technical specifications

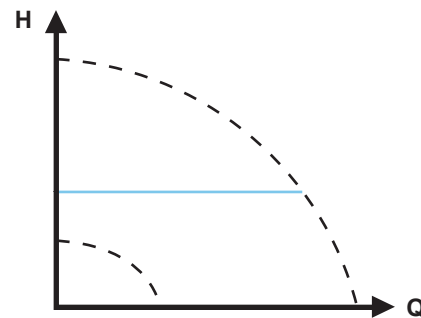

TM052449

### Constant-pressure control

## Constant temperature

This control mode is suitable in systems with a fixed system characteristic, for example domestic hot-water systems, where the control of the pump according to a constant return-pipe temperature is relevant.

The pump is from factory set to operate in a heating system with a controller gain,  $K_p$ , equal to 1. If the pump operates in a cooling system, the gain must be changed to a negative value, for example -1. This is done via the operating panel of the pump.

### Characteristics and key benefits

- The temperature is kept constant.
- FLOWLIMIT is used to control the maximum circulation flow rate.

### Technical specifications

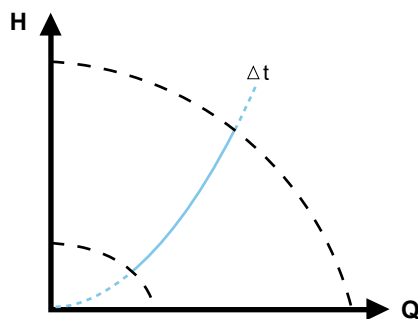

Constant-temperature control

Note that the older MAGNA3 Model A pump does not support the inverse control for cooling application.

## Temperature sensor

If the pump is installed in the flow pipe, install an external temperature sensor in the return pipe of the system. See the figure below. Install the sensor as close as possible to the consumer (radiator, heat exchanger, etc.).

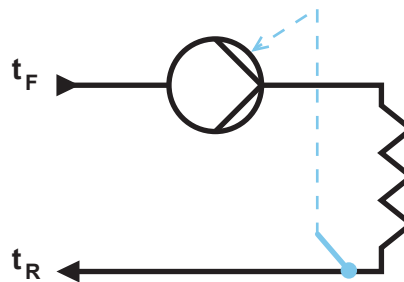

TM052615

Pump with an external sensor

If the pump is installed in the return pipe of the system, you can use the internal temperature sensor. In this case, install the pump as close as possible to the consumer (radiator, heat exchanger, etc.).

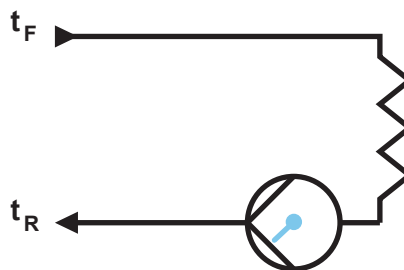

TM052616

Pump with an internal sensor

## Differential temperature

Select this control mode if the pump performance is to be controlled according to a differential temperature in the system where the pump is installed.

### Characteristics and key benefits

- Ensures a constant differential temperature drop across heating and cooling systems.
- Ensures a constant differential temperature between the pump and the external sensor, see sections Technical specifications and Temperature sensor.
- Requires two temperature sensors, the internal temperature sensor together with an external sensor.

### Related information

[Technical specifications](#)

[Temperature sensor](#)

### Technical specifications

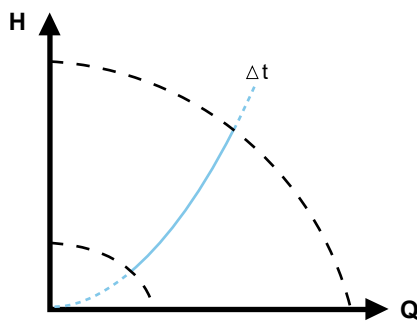

TM079515

*Differential temperature*

## Temperature sensor

To measure the temperature difference of the flow pipe and the return pipe, you must use both the internal sensor and an external sensor. If the pump is installed in the flow pipe, the external sensor must be installed in the return pipe and vice versa. Always install the sensor as close as possible to the consumer (radiator, heat exchanger, etc.).

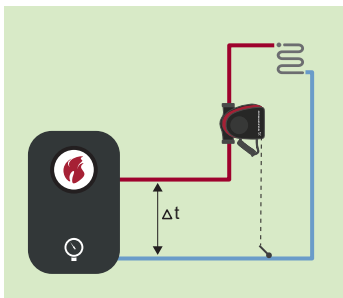

TM070362

*Differential temperature*

## Constant flow

**Note:** Available for pumps with production code from 1838. The pump maintains a constant flow in the system independently of the head. See section Characteristics and key benefits.

Constant flow is suitable in applications such as air handling units, hot-water systems and ground-source heating systems.

### Related information

[Characteristics and key benefits](#)

### Characteristics and key benefits

- It is not possible to use an external sensor, instead, the pump uses its internal sensor.
- In multipump systems constant flow is only available in alternating and backup operation, not cascade operation.

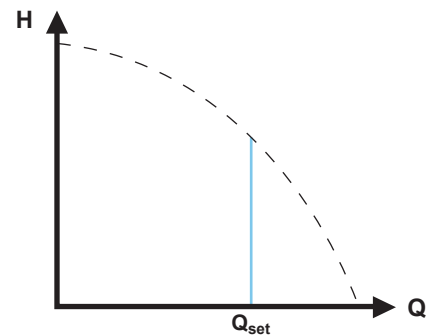

TM071240

*Constant flow rate*

## Constant curve

A constant curve is suitable for systems, where both a constant flow rate and a constant head are required, i.e.:

- Heat surfaces
- cooling surfaces
- heating systems with 3-way valves
- air condition system with 3-way-valve
- chiller pumps

### Characteristics and key benefits

- If an external controller is installed, the pump is able to change from one constant curve to another, depending on the value of the external signal.
- Depending on your preferences, the pump can be controlled according to either a maximum or minimum curve.

## Technical specifications

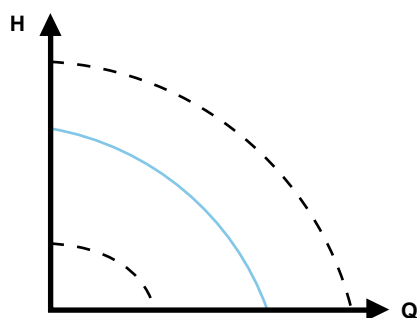

### Constant-curve duty

The pump can be set to operate according to a constant curve, like an uncontrolled pump. See the figure above.

Depending on the pump model, you can set the desired speed in % of the maximum speed. The span of control depends on the minimum speed, power and pressure limitation of the pump.

**Note:** If the pump speed is set in the range between minimum and maximum, the power and pressure are limited when the pump is running on the maximum curve. This means that the maximum performance can be achieved at a speed lower than 100 %. See the figure below.

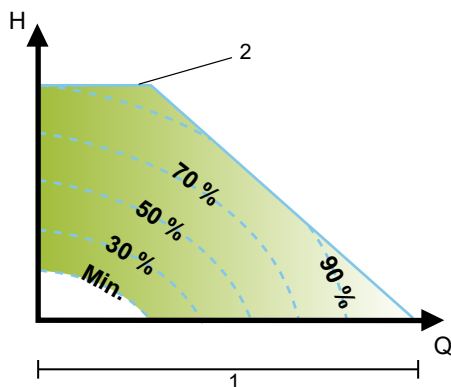

### Power and pressure limitations influencing the maximum curve

Pos.	Description
1	Limited max. curve
2	Speed setting from 0 to 100 %

You can also set the pump to operate according to the maximum or minimum curve, like an uncontrolled pump:

- You can use the maximum curve mode in periods where a maximum flow rate is required. This operating mode is for instance suitable for hot-water priority.
- You can use the minimum curve mode in periods where a minimum flow rate is required. This operating mode is for instance suitable for manual night setback if automatic night setback is not desired.

You can select these two operating modes via the digital inputs.

In the control mode constant curve, you can obtain a constant flow by choosing a setpoint at 100 % and choosing the desired value for the flow rate with the FLOWLIMIT function. Take the accuracy of the flow rate estimation into consideration.

TM081472

TM056242

### Additional control mode features

MAGNA3 offers additional features for the control modes to meet specific demands.

#### FLOWLIMIT

The feature is an integrated part of the FLOWADAPT control mode, but is also advantageous in:

- proportional-pressure mode
- constant-pressure mode
- constant-temperature mode
- constant-curve mode
- differential-temperature mode.

#### Characteristics and key benefits

- A control mode feature that, when activated, ensures that the rated maximum flow is never exceeded.
- By enabling FLOWLIMIT in systems where MAGNA3 has full authority, the rated flow is never exceeded, thus eliminating the need for throttling valves.

#### Technical specifications

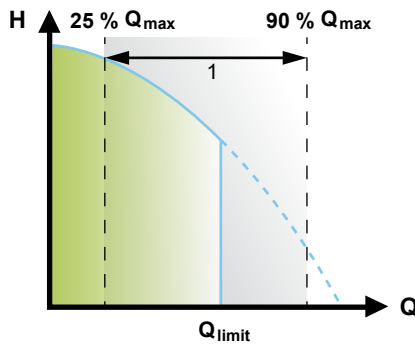

TM052445

#### FLOWLIMIT

Pos.	Description
1	Setting range

The setting range for the FLOWLIMIT is 25 to 90 % of the Q<sub>max</sub> of the pump.

**Note:** Do not set the FLOWLIMIT lower than the dimensioned duty point.

In the flow rate range between 0 and Q<sub>limit</sub>, the pump will run according to the selected control mode.

When Q<sub>limit</sub> is reached, the FLOW<sub>LIMIT</sub> function will reduce the pump speed to ensure that the flow rate never exceeds the FLOW<sub>LIMIT</sub> set, no matter if the system requires a higher flow rate due to an increased resistance in the system. See the figures below.

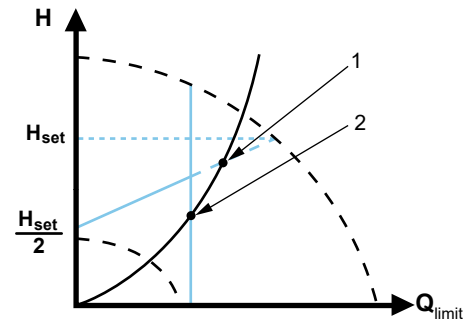

TM052543

Proportional-pressure control with FLOWLIMIT

Pos.	Description
1	Normal proportional-pressure duty point
2	FLOWLIMIT duty point

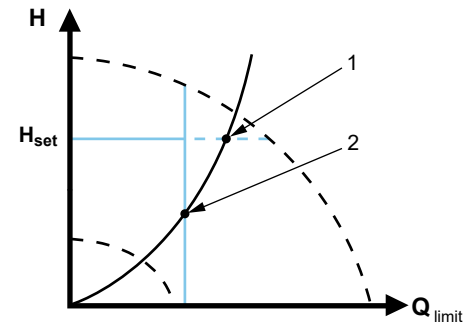

TM052544

Constant-pressure control with FLOWLIMIT

Pos.	Description
1	Normal constant-pressure duty point
2	FLOWLIMIT duty point

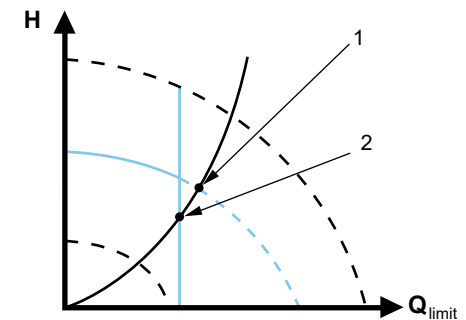

TM052542

Constant curve with FLOWLIMIT

Pos.	Description
1	Normal constant-curve duty point
2	FLOW <sub>LIMIT</sub> duty point

### Automatic night setback

A night setback system is often integrated into a building management system (BMS), or as part of an equivalent electronic control system, which has a built-in timer.

The feature is not beneficial in rooms with underfloor heating because of the regulating inertia of the underfloor heating.

### Characteristics and key benefits

- Automatic night setback lowers the room temperature at night, which reduces heating costs.
- The pump automatically changes between normal duty and night setback (duty at low demand), depending on the flow pipe temperature.
- Once activated, the pump runs on the minimum curve.

### Technical specifications

The pump automatically changes to night setback when the built-in sensor registers a flow-pipe temperature drop of more than 18 to 27 °F (10 to 15 °C) within approximately two hours. The temperature drop must be at least 0.18 °F/min (0.1 °C/min).

Changeover to normal duty takes place without time lag when the temperature has increased by approximately 18 °F (10 °C).

**Note:** You cannot enable automatic night setback when the pump is in constant-curve mode.

## Multipump modes

### Multipump function

The multipump function enables control of single-head pumps connected in parallel and twin-head pumps without the use of external controllers. The pumps in a multipump system communicate with each other via the wireless GENlair connection.

Pump system:

- Twin-head pump.
- Two single-head pumps connected in parallel. The pumps must be of equal size and type. Each pump requires a non-return valve in series with the pump.

A multipump system is set via a selected pump, i.e. the master pump (first selected pump). The multipump functions are described in the following sections.

### Alternating operation

Only one pump is operating at a time. The change from one pump to the other depends on time or energy. If a pump fails, the other pump will take over automatically.

### Backup operation

One pump is operating continuously. The backup pump is operated at intervals to prevent seizing up. If the duty pump stops due to a fault, the backup pump will start automatically.

### Cascade operation

Cascade operation ensures that the pump performance is automatically adapted to the consumption by switching pumps on or off. The system thus runs as energy-efficiently as possible with a constant pressure and a limited number of pumps.

The slave pump starts when the master pump either runs at 90 % of the maximum speed or runs on the maximum curve. The slave pump stops if one of the following conditions are fulfilled:

- One of the two pumps runs on minimum curve.
- One of the two pumps runs below 50 % of the maximum speed and at the same time runs below 50 % of the maximum power consumption.

Cascade operation is available in constant speed and constant pressure. You can with advantage choose a twin-head pump as the backup pump will start for a short period in peak-load situations.

All pumps in operation will run at equal speed. Pump changeover is automatic and depends on speed, operating hours and faults.

## Flow estimation accuracy

The calculated flow rate has a typical accuracy of  $\pm 5\%$  of  $Q_{max}$ . The less flow through the pump, the less accurate the reading will be. In worst case scenarios, such as closed valve operation, the accuracy can be up to 10 % of  $Q_{max}$ . See section Heat energy monitor.

Example:

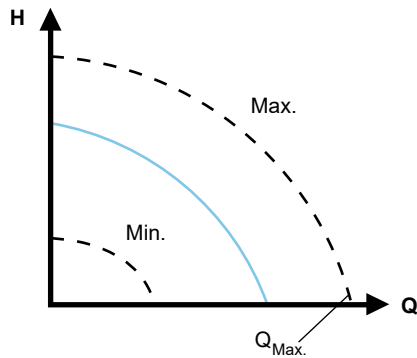

TM081473

$Q_{max}$

1. MAGNA3 65-60 has a  $Q_{max}$  of 40 m<sup>3</sup>/h. A typical 5 % accuracy means 2 m<sup>3</sup>/h inaccuracy of  $Q_{max} \pm 2$  m<sup>3</sup>/h.
2. This accuracy is valid for the entire QH area. If the pump indicates 10 m<sup>3</sup>/h, the measurement is  $10 \pm 2$  m<sup>3</sup>/h.
3. The flow rate can be 8-12 m<sup>3</sup>/h.

**Note:** Use of a water/ethylene glycol mixture will decrease the accuracy.

### Related information

[Heat energy monitor](#)

### Low flow indication

The pump can experience low flow due to for example valves being shut. In cases where the flow is below 10 % of the maximum flow, thus too low for the pump's internal sensor to measure, it will be stated on the MAGNA3 display. A speed measurement will tell you that the pump is still running.

When the flow is high enough for the pump to measure, the MAGNA3 display returns to normal.

## Readings on the pump

### Performance overview

The home menu allows you to quickly gain an overview of the main settings of up to four user-defined parameters or view a graphical illustration of a QH performance curve.

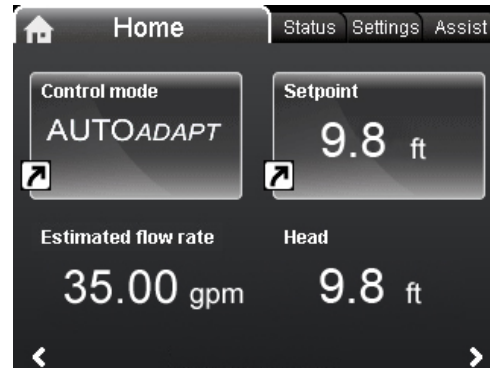

UNDEF-010\_HOME\_US

Example of Home menu with overview of settings and performance

### Operating status and pump performance

The status menu shows the current operating mode and the selected control mode, if any. Here, you can also review the performance of the pump:

- QH graph showing current duty point, flow rate, head, power and liquid temperature.
- "Resulting setpoint" showing the setpoint set on the pump, the external influence and the resulting setpoint.
- Liquid temperature.
- Speed.
- Operating hours.

### Warning and alarm

The **Warning and alarm** menu provides information on:

- actual warning or alarm, if any
- information about when the warning or alarm occurred, disappeared and about corrective actions
- Warning and alarm logs.

## Heat energy monitor

Heat energy monitor is a monitoring function which makes it possible to track the heat energy distribution and consumption within a system. This prevents excessive energy costs caused by system imbalances.

The pump requires a temperature sensor in the flow pipe or the return pipe. This temperature sensor is not supplied with the pump.

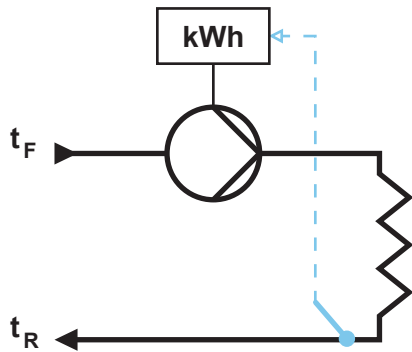

TMD55367

MAGNA3 with built-in heat energy monitor

**Note:** MAGNA3 incorporates a calculator for flow and media temperature, see section External Grundfos sensors.

### Related information

[External Grundfos sensors](#)

## Heat consumption accuracy

The built-in flow estimation needed for the calculation has a typical accuracy of  $\pm 5\%$  of  $Q_{max}$ . The less flow through the pump, the less accurate the reading will be. In worst case scenarios such as closed valve operation, the accuracy can be up to  $10\%$  of  $Q_{max}$ . The actual accuracy in a duty point will be shown in the MAGNA3 display (this feature is available for pumps with production code from 1838).

The temperature measurement accuracy also depends on the sensor type. Therefore, you cannot use the heat energy value for billing purposes. However, the value is perfect for optimisation purposes in order to prevent excessive energy costs. See section Readings on the pump.

To counterbalance any inaccuracy on either the internal and external sensor, it is possible to manually enter a temperature offset. The offset is entered in integers, for example 2 degrees.

**Note:** Temperature sensor offset is available for pumps with production code from 1838.

### Related information

[Flow estimation accuracy](#)

## Operating log

The **Operating log** is the perfect tool for pump optimization, replacement and fault finding as it offers the following:

- All duty points and operating conditions are tracked and stored in the pump.
- The 3D work log and duty curve (over time) provide instant overviews of historical pump performance and operating conditions.

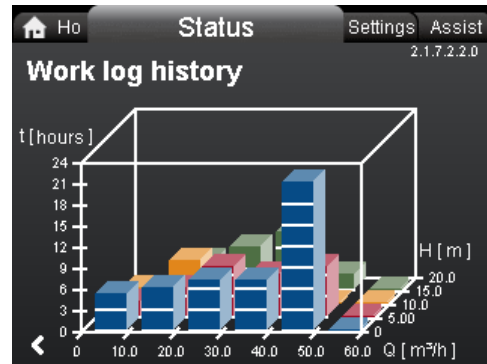

Example of Operating log

## Help and guidance

The Assist menu guides you through the setup of the pump and offers the following:

- step-by-step instructions in how to set the pump
- a short description of the six control modes and recommended applications
- assistance with fault correction
- fault advice
- multipump setup
- setup, analog input
- description of control mode.

## Grundfos Eye

Grundfos Eye at the top of the operating panel is a pump status indicator light providing information about the pump operating status.

The indicator light will flash in different sequences and provide information about the following:

- power on or off
- pump warnings
- pump alarms
- remote control
- pump running or stopped.

The function of Grundfos Eye is described in detail in the installation and operating instructions.



Grundfos Eye

TM082052

## Communication

MAGNA3 enables communication via the following:

- wireless communication to the Grundfos GO app via Bluetooth or infrared connection
- fieldbus communication via add-on CIM modules (accessory)
- digital inputs
- relay outputs
- analog input.

### Wireless Grundfos GO

The MAGNA3 Model E pump communicates wirelessly with Grundfos GO via Bluetooth, which allows you to connect directly to the Grundfos GO app on your smart device without any need for a dongle.

With Grundfos GO, you can monitor your pump, change settings, collect data and make reports. A user-friendly interface provides you with all the information and help you need, as well as live pump data monitoring and easy-to-follow tips and guides.

The Grundfos GO app is free of charge and available for iOS and Android devices.

For further details, see the section on Grundfos GO.

### Related information

[Grundfos GO](#)

### Wireless GENlair

The pump is designed for multipump connection via the wireless GENlair connection.

The built-in wireless GENlair module enables communication between pumps and with Grundfos GO without the use of add-on modules:

- Multipump function.  
See section Multipump function.
- Grundfos GO.  
See section Grundfos GO.

### Related information

[Multipump function](#)

[Grundfos GO](#)

## Communication interface modules, CIM

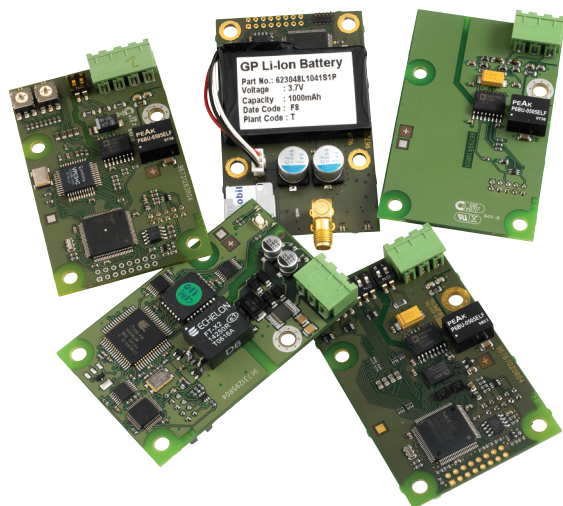

TM053811

### Grundfos CIM modules

The Grundfos CIM module is an add-on communication interface module which communicates via fieldbus protocols. The CIM module enables data transmission between the pump and an external BMS (Building Management System) or a SCADA system.

The CIM module only needs to be installed in the master pump. MAGNA3 has an integrated booster profile which enables data in the slave to be monitored by the master. For a list of compatible CIM modules that support the booster profile, see the section on CIM modules available for MAGNA3. Note that the older MAGNA3 model A and B pumps require a CIM module installed in both the master and the slave pump.

For descriptions of compatible CIM modules, see the section on CIM modules and protocols.

### Related information

[CIM modules and protocols](#)

[CIM modules available for MAGNA3](#)

### CIM modules and protocols

Due to different regulations in different countries, not all the communication interface modules (CIM) in the list below can be used worldwide. Please contact Grundfos for detailed information on the CIM modules and the Grundfos iSOLUTIONS Cloud applications available in your region. <sup>1)</sup>

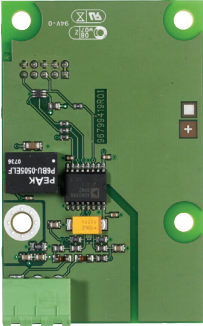
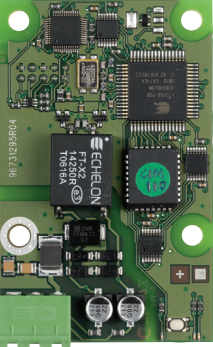
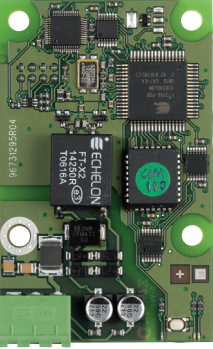
Module	Fieldbus protocol	Description	Functions
CIM 050			
 <p>TM067238</p>	GENIbus	CIM 050 is a Grundfos communication interface module used for communication with a GENIbus network.	CIM 050 has terminals for the GENIbus connection.
CIM 100			
 <p>TM067279</p>	LonWorks	CIM 100 is a Grundfos communication interface module used for communication with a LonWorks network.	CIM 100 has terminals for the LonWorks connection. Two LEDs indicate the actual status of the CIM 100 communication: One LED indicates correct connection to the pump, and the other LED indicates the LonWorks communication status.
CIM 110			
 <p>TM067279</p>	LonWorks for twin pump	CIM 110 is a Grundfos communication interface module for communication with a LON network. CIM 110 is installed in the master head of a twin pump.	CIM 110 has FTT-10 terminals for the LonWorks connection. Two LEDs indicate the actual status of the CIM 100 communication: One LED indicates correct connection to the pump, and the other LED indicates the LonWorks communication status.

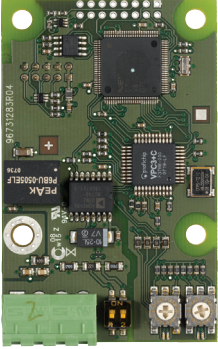
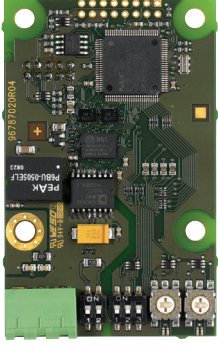
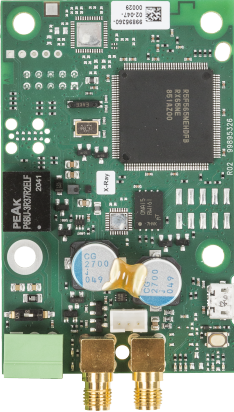
Module	Fieldbus protocol	Description	Functions
CIM 150	PROFIBUS DP	CIM 150 is a Grundfos communication interface module used for communication with a PROFIBUS network.	<p>CIM 150 has terminals for the PROFIBUS DP connection.</p> <p>DIP switches are used to set line termination.</p> <p>Two hexadecimal rotary switches are used to set the PROFIBUS DP address.</p> <p>Two LEDs indicate the actual status of the CIM 150 communication: One LED indicates correct connection to the pump, and the other LED indicates the PROFIBUS communication status.</p>
 TM067280			
CIM 200	Modbus RTU	CIM 200 is a Grundfos communication interface module used for communication with a Modbus RTU network.	<p>CIM 200 has terminals for the Modbus connection.</p> <p>DIP switches are used to select parity and stop bits, to select transmission speed and to set line termination.</p> <p>Two hexadecimal rotary switches are used to set the Modbus address.</p> <p>Two LEDs indicate the actual status of the CIM 200 communication: One LED indicates correct connection to the pump, and the other LED indicates the Modbus communication status.</p>
 TM067281			
CIM 280-US GIC GEN2	Cellular GiC	<p>CIM 280-US GIC GEN2 is a Grundfos communication interface for communication via a cellular network to Grundfos iSOLUTIONS Cloud applications.</p> <p>Supports North American frequency bands in USA and Canada.</p> <p>The Grundfos iSOLUTIONS Cloud requires a subscription.<sup>1)</sup></p>	<p>CIM 280-US GIC GEN2 has a SIM-card slot and an SMA connection for a cellular antenna.</p> <p>CIM 280-US GIC GEN2 can be fitted with a lithium-ion battery. Only insert the approved Grundfos battery pack.</p> <p>Two LEDs indicate the actual status of the CIM 280-US GIC GEN2 communication: One LED indicates correct connection to the pump, and the other LED indicates the cellular communication status.</p> <p>An eUICC SIM card is supplied with the CIM 280-US. The costs for the data traffic is part of the Grundfos iSolutions Cloud subscription.</p> <p>An external 4G/3G antenna with mounting bracket is available as accessory for North America.</p>
 TM084170			

Module	Fieldbus protocol	Description	Functions
CIM 290-MA LPWAN GiC	Cellular LTE-M GiC	<p>CIM 290-MA LPWAN GiC is a Grundfos communication interface module used for cellular data transmission from a Grundfos pump or a predefined Modbus RTU slave to Grundfos iSOLUTIONS Cloud applications. The Grundfos iSOLUTIONS Cloud requires a subscription.<sup>1)</sup></p>	<p>CIM 290-MA LPWAN GiC has a SIM-card slot and an SMA connection for a cellular antenna.</p> <p>CIM 290-MA LPWAN GiC has an RS-485 port for GENIbus and Modbus RTU slave connection and a BLE radio for commissioning via Grundfos GO.</p> <p>Three LEDs indicate the status of the cellular communication, the internal communication to the Grundfos product, and the RS-485 communication.</p> <p>An eUICC SIM card is preinstalled in the SIM-card slot. The SIM card includes a Grundfos-specific roaming profile which requires a contract with Grundfos.</p> <p>An external 4G antenna with mounting bracket is available as accessory for EU and Australia. For EU, an optional antenna with magnetic foot is available as accessory.</p>

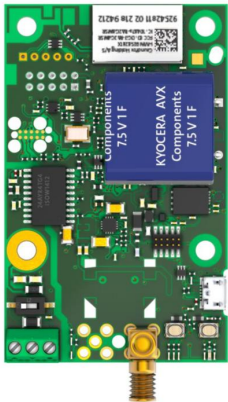

TM090745

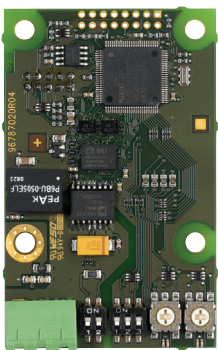
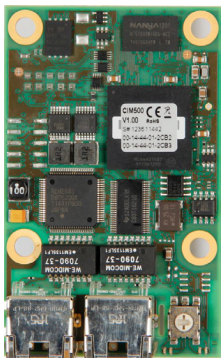
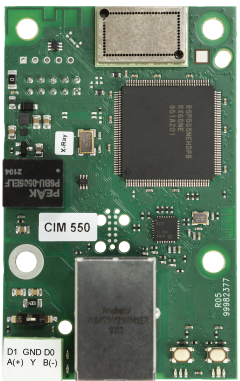
Module	Fieldbus protocol	Description	Functions
CIM 300	BACnet MS/TP	CIM 300 is a Grundfos communication interface module used for communication with a BACnet MS/TP network.	<p>CIM 300 has terminals for the BACnet MS/TP connection.</p> <p>DIP switches are used to set transmission speed and line termination and to select the custom Device Object Instance Number.</p> <p>Two hexadecimal rotary switches are used to set the BACnet address.</p> <p>Two LEDs indicate the actual status of the CIM 300 communication: One LED indicates correct connection to the pump, and the other LED indicates the BACnet communication status.</p>
 TM067281			
CIM 500	Ethernet	<p>CIM 500 is a Grundfos communication interface module used for data transmission between an industrial Ethernet network and a Grundfos product.</p> <p>CIM 500 supports various industrial Ethernet protocols:</p> <ul style="list-style-type: none"> <li>• PROFINET</li> <li>• Modbus TCP</li> <li>• BACnet IP</li> <li>• EtherNet/IP</li> </ul>	<p>CIM 500 supports various industrial Ethernet protocols.</p> <p>CIM 500 is configured via the built-in web server, using a standard web browser on a PC.</p>
 TM067283			
CIM 550	Ethernet GiC	<p>CIM 550 Ethernet GiC is a Grundfos communication interface used for communication via LAN and internet to Grundfos iSOLUTIONS Cloud applications.</p> <p>The Grundfos iSOLUTIONS Cloud requires a subscription.<sup>1)</sup></p>	<p>CIM 550 Ethernet GiC has an RJ-45 interface for LAN connection, an RS-485 port for GENibus and Modbus RTU slave connection, and a BLE radio for commissioning via Grundfos GO.</p> <p>Two LEDs indicate the actual status of the CIM 550 communication: One LED indicates correct connection to the pump, and the other LED indicates LAN connection to Grundfos iSOLUTIONS Cloud applications.</p> <p>Due to regional regulations and approvals, please reach out to Grundfos to verify if your Grundfos iSOLUTIONS Cloud application is supported in your country.</p>
 TM084171			

<sup>1)</sup> Contact Grundfos to verify that your product and application is supported from the cloud, as this depends on the available cloud driver and regional frequency bands and approvals.

The above CIM modules, antennas and battery packs are available as accessories. For part numbers, please see the section on CIM modules available for MAGNA3.

### Related information

[CIM modules available for MAGNA3](#)

### Grundfos Remote Management

Grundfos Remote Management is an easy-to-install, low-cost solution for wireless monitoring and management of Grundfos products. GRM is based on a centrally hosted database and a web server with wireless data collection via GSM/GPRS modem. The system only requires an internet connection, a web browser, a GRM modem and an antenna as well as a contract with Grundfos allowing you to monitor and manage Grundfos pump systems.

You have wireless access to your account anywhere and anytime you have an internet connection, for example via a smartphone, tablet PC, laptop or computer. Warnings and alarms can be sent by email or SMS to your mobile phone or computer.

For information about the CIM communication interface module and GSM antennas, see section Grundfos Remote Management.

#### Related information

[Grundfos Remote Management](#)

### Digital inputs

You can use the digital input for external control of start or stop or forced maximum or minimum curve.

**Note:** If no external on and off switch is connected, maintain the jumper between the Start/Stop (S/S) and frame ( $\perp$ ) terminals. This connection is the factory setting.

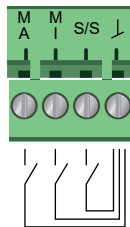

TM079522

Digital input in control box

Contact symbol	Function
M A	Maximum curve
M I	Minimum curve
S/S	Start/Stop
$\perp$	Frame connection

### External start or stop

You can start and stop the pump via the digital input.

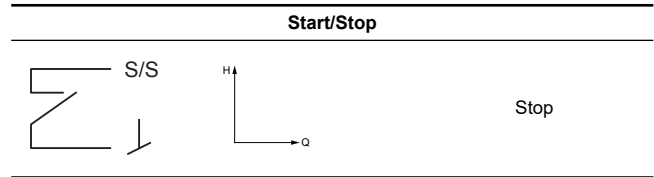
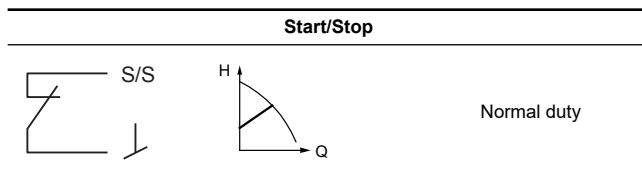

### External forced maximum or minimum curve

You can force the pump to operate on the maximum or minimum curve via the digital input.

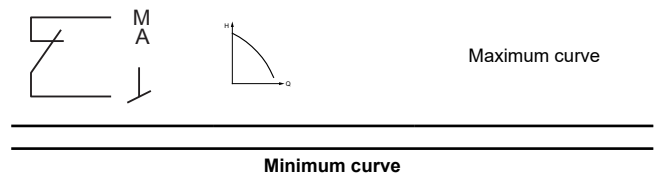
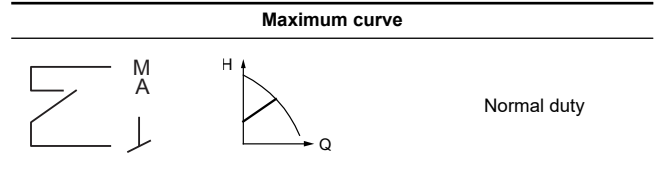

### Relay outputs

The pump has two signal relays with a potential-free changeover contact for external fault indication.

You can set the function of the signal relay to **Alarm**, **Ready** or **Operation** on the pump operating panel or with Grundfos GO.

Factory settings of relays:

Relay	Function
1	Operation signal
2	Alarm signal

**Note:** You can configure both relays to "ready, alarm or operating".

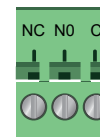







TM079523

Relay output in the control box

Contact symbol	Function
NC	Normally closed
NO	Normally open
C	Common

The functions of the signal relays are as shown in the table below:

Signal relay	Alarm signal
	Not activated: <ul style="list-style-type: none"> <li>The power supply has been switched off.</li> <li>The pump has not registered a fault.</li> </ul>
	Activated: <ul style="list-style-type: none"> <li>The pump has registered a fault.</li> </ul>
Signal relay	Ready signal
	Not activated: <ul style="list-style-type: none"> <li>The pump has registered a fault and is unable to run.</li> </ul>
	Activated: <ul style="list-style-type: none"> <li>The pump has been set to stop, but is ready to run.</li> <li>The pump is running.</li> </ul>
Signal relay	Operating signal
	Not activated: <ul style="list-style-type: none"> <li>The pump is not running.</li> </ul>
	Activated: <ul style="list-style-type: none"> <li>The pump is running.</li> </ul>

## Analog input for an external sensor

To optimize pump performance, you can use the analog input for the connection of an external sensor in the following cases:

Function/control mode	Sensor type
Heat energy monitor	
Constant temperature	Temperature sensor
Differential temperature	
Constant pressure	Differential-pressure transmitter

### Controlling the flow in the system

When using an external differential-pressure sensor to control the flow in the system, you obtain the externally set pressure, which results in the following benefits:

- minimizes operating costs
- prevents valve noise
- ensures comfort (adequate pressure).

When setting this function, make sure that the pump is set to run in constant-pressure mode and that "Differential-pressure control" has been activated in the "Analog input" menu on the pump's operating panel.

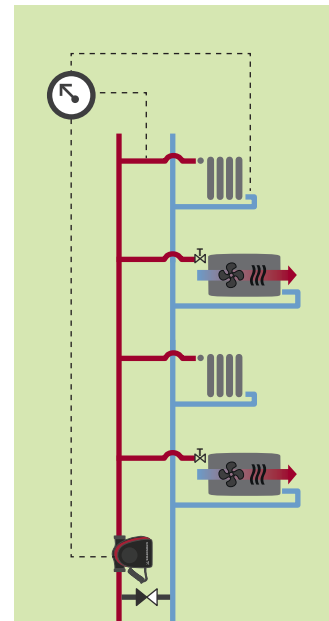

External differential-pressure sensor

TM070361

The electrical signal for the input can be 0-10 V or 4-20 mA. You can change the selection of the electrical signal (0-10 V or 4-20 mA) on the operating panel or with Grundfos GO.

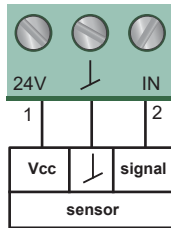

Analog input for an external sensor or control

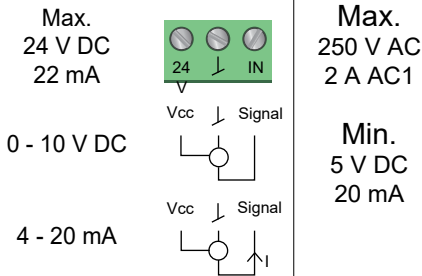

Wiring, analog input

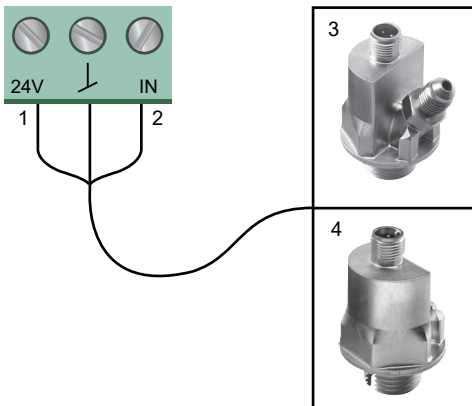

Examples of external sensors

Pos.	Sensor type
1	Vcc
2	Signal
3	Differential-pressure transmitter, Grundfos type DPI V.2 1/2" connection and 4-20 mA signal.
4	Relative-pressure transmitter. Combined temperature and pressure sensor, Grundfos type RPI T2. 1/2" connection and 0-10 V signal.

For further details, see section External Grundfos Sensors.

**Related information**

[External Grundfos sensors](#)

**External control system**

The analog input can be used for an external signal for the control from a BMS system or similar control system.

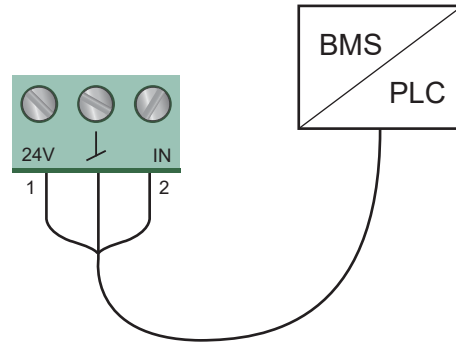

Example of an external signal for the control via BMS or PLC

## External setpoint function

You can use the analog input to influence the setpoint externally.

The external setpoint function can be used in two different ways:

- Linear with Min.
- Linear with Stop (available for pumps with production code from 1838)

In both modes the input signal range is influenced linearly.

### Linear with Min.

Here, a 0-10 V or 4-20 mA signal controls the pump speed range in a linear function. The range of control depends on the minimum speed, power and pressure limits of the pump. See the figures below.

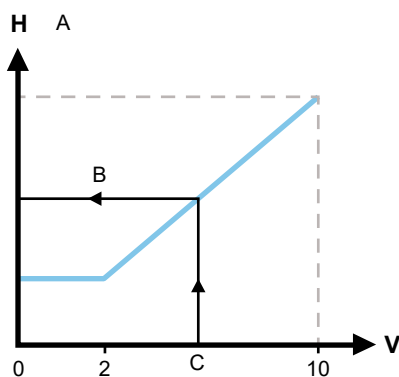

Linear with Min., 0-10 V

Pos.	Description
A	(user setpoint)
B	Resulting setpoint
C	Analog input

  

Control	
0-2 V (0-20 %)	Resulting setpoint is equal to minimum.
2-10 V (20-100 %)	Resulting setpoint is between minimum and user setpoint.

TM069149

## Linear with Stop

**Note:** Available for pumps with production code from 1838. Here, if the input signal is below 10 %, the pump changes to operating mode "Stop". If the input signal is increased above 15 %, the operating mode is changed back to "Normal".

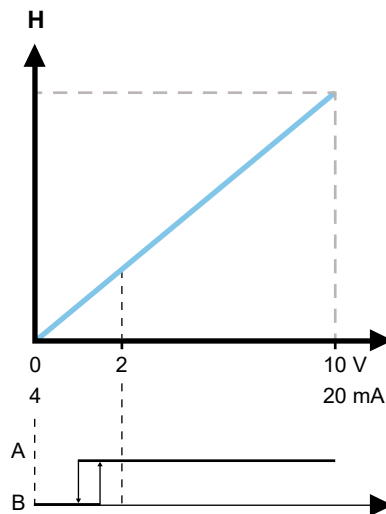

"Linear with Stop", 0-10 V

Pos.	Description
A	Normal
B	Stop

TM071250

## External setpoint function according to model

The external setpoint function operates differently, depending on the model. For model A,B and C, the maximum speed is often obtained at voltages lower than 10 V as the span of control is limited.

In models newer than A,B, and C, the internal scaling has been optimised making the dynamic area bigger, thus giving a better control of the pump speed when using the external setpoint function.

The same applies if the pump is receiving a set point from Building Management Systems.

## 5. Operating conditions

### General recommendations

<b>Water in heating systems</b>	Water quality according to local standards
<b>Domestic hot water</b>	Degree of hardness up to 14 °dH
<b>Water containing glycol</b>	Maximum viscosity = 10 cSt ~ 50 % water and 50 % ethylene glycol at +14 °F (-10 °C)

### Liquid temperature

Application	Temperature range
General	+14 to +230 °F (-10 to +110 °C)
Domestic hot-water systems	Up to 149 °F (65 °C) recommended

### Ambient conditions

Ambient conditions	
Ambient temperature during operation	-4 to +104 °F (-20 to +40 °C)
Ambient temperature during storage and transport	-40 to +158 °F (-40 to +70 °C)
Relative humidity	Max. 95 %

### Ambient temperatures below 32 °F

When operating the pump at ambient temperatures below 32 °F (0 °C) observe below requirements to reduce condensation and avoid ice buildup.

Requirements for operation below 32 °F (0 °C)	Media type	
	Glycol mix	Water
Media temperature at min. 41 °F (5 °C)	-	•
Power switched on permanently	•	•
Continuous operation	-	•
Twin-head pumps: cascade operation every 24 hours	•	•

### Closed valve operation

MAGNA3 pumps can operate at any speed against a closed valve for several days without damage to the pump. However, Grundfos recommends you to operate at the lowest possible speed curve to minimise energy losses. There are no minimum flow requirements.

**Note:** Do not close inlet and outlet valves simultaneously, always keep one valve open when the pump is running to avoid pressure buildup. Media and ambient temperatures must never exceed the specified temperature range.

### Location

The product is designed for indoor use only.

To ensure sufficient cooling of motor and electronics, observe the following requirements:

- Position the product in such a way that sufficient cooling is ensured.
- The ambient temperature must not exceed 104 °F (40 °C).
- The altitude must not exceed 6560 ft (2000 m) above sea level.

### Requirements to the installation site

Always install the product in a dry environment where it will not be exposed to drops or splashes of liquid from surrounding equipment or structures, for example condensed water.

The product is intended for indoor installation only. If you install the product in a location where the environmental conditions may vary, follow all local regulations and requirements and make sure to fulfill these requirements:

- Comply with the operating conditions and enclosure class specified for the product.
- Provide shielding from direct exposure to sunlight, rain, snow and other environmental factors.
- Do not expose the product to UV radiation.
- Keep the drain holes clear of any blockage.
- Collect and remove condensation buildup.

### Aggressive environments

It is important to avoid direct installation in aggressive environments such as the following:

- indoor swimming pools, where the product is exposed to the ambient environment of the pool
- locations with direct and continuous exposure to a marine atmosphere
- locations where hydrochloric acid (HCl) can form acidic aerosols, for example when acid escapes from open tanks or from frequently opened or vented containers.

The above applications do not disqualify for installation of the product. However, it is important that the product is not installed directly in these environments.

### Cooling applications

In cooling applications condensation may occur on the surface of the pump. In certain cases, it is necessary to mount a drip tray.

To protect the electronics, power on the pump must be switched on, if the cold water is forced through the pump.

## Maximum operating pressure

Maximum operating pressure			
MAGNA pump	[psi]	[bar]	[MPa]
PN 6	87	6	0.6
PN 10	145	10	1.0
PN 12	175	12	1.2

Note that not all variants are available in all markets.

## Test pressure

The pumps can withstand test pressures as indicated in EN 60335-2-51. See below.

Test pressure			
MAGNA pump	[psi]	[bar]	[MPa]
PN 6	104.4	7.2	0.72
PN 10	175	12	1.2
PN 6/10	175	12	1.2
PN 12	175	12	1.2

Not all variants are available in all markets.

During normal operation, do not use the pump at higher pressures than those stated on the nameplate.

The pressure test has been made with water containing anticorrosive additives at a temperature of 68 °F (20 °C).

## Minimum inlet pressure

The following relative minimum inlet pressure must be available at the pump inlet during operation to avoid cavitation noise and damage to the pump bearings.

The actual inlet pressure plus the pump pressure against a closed valve must be lower than the maximum permissible system pressure stated on the pump nameplate.

MAGNA3	Liquid temperature			
	77 °F (25 °C)	167 °F (75 °C)	203 °F (95 °C)	230 °F (110 °C)
	Inlet pressure [psi (bar)]			
25-40/60/80/100/120	0 (0.0)	1.5 (0.10)	5 (0.35)	14.5 (1.0)
32-40/60/80/100/120	0 (0.0)	1.5 (0.10)	5 (0.35)	14.5 (1.0)
32-40/60/80/100/120 F	0 (0.0)	1.5 (0.10)	5 (0.35)	14.5 (1.0)
32-120 F	0 (0.0)	1.5 (0.10)	2.9 (0.2)	10.15 (0.7)
40-40/60 F	0 (0.0)	1.5 (0.10)	5 (0.35)	14.5 (1)
40-80/100/120/150/180 F	0 (0.0)	1.5 (0.10)	7.25 (0.5)	14.5 (1)
50-40/60/80 F	0 (0.0)	1.5 (0.10)	5.8 (0.4)	14.5 (1)
50-100/120 F	0 (0.0)	1.5 (0.10)	7.25 (0.5)	14.5 (1)
50-150/180 F	5.8 (0.4)	10.15 (0.70)	17.4 (1.2)	24.66 (1.7)
65-40/60/80/100/120/150 F	5.8 (0.4)	10.15 (0.70)	17.4 (1.2)	24.66 (1.7)
80-40/60/80/100/120 F	2.9 (0.2)	7.25 (0.50)	14.5 (1.0)	21.76 (1.5)
100-40/60/80/100/120 F	5.8 (0.4)	10.15 (0.70)	17.4 (1.20)	24.66 (1.7)



The values in the above table apply to single-head pumps and twin-head pumps in single-head operation installed up to 300 metres above sea level.

**Inlet pressure in cascade operation:** In the case of cascade operation, increase the required relative inlet pressure by 1.45 psi (0.1 bar, 0.01 MPa) compared to the stated values for single-head pumps or for twin-head pumps in single-head operation.

**Inlet pressure at altitudes above 300 metres:** The relative minimum inlet pressures apply to pumps installed up to 984 ft (300 metres) above sea level. For altitudes above 984 ft (300 metres), increase the required relative inlet pressure by 0.145 psi (0.01 bar, 0.001 MPa) per 328 ft (100 metres) altitude. The pump is only approved for an altitude of maximum 6560 ft (2000 metres) above sea level.

**Note:** Not all variants are available in all markets.

## Pumped liquids

The product is suitable for pumping thin, clean, non-aggressive and non-explosive liquids, not containing solid particles or fibers or mineral oils that may attack the pump mechanically or chemically.

### Liquid requirements for heating and cooling systems

In heating and cooling systems, the water must meet the requirements of accepted standards, codes, and any authority having jurisdiction (AHJ) requirements.

In heating systems, the water must meet the requirements of accepted standards on water quality in heating systems, for example the German standard VDI 2035.

You can pump water-glycol mixtures with up to 50 % glycol.

### Liquid requirements for pool applications

Stainless steel variants of the MAGNA pump can be used to pump pool water with one of the following properties:

- Chloride (Cl-)  $\leq$  150 mg/l and free chlorine  $\leq$  1.5 mg/l at temperatures  $\leq$  86 °F ( $\leq$  30 °C)
- Chloride (Cl-)  $\leq$  100 mg/l and free chlorine  $\leq$  1.5 mg/l at temperatures from 86 to 104 °F (30 to 40 °C).

### Liquid requirements for domestic hot-water applications

In domestic hot-water applications, Grundfos strongly recommends the following:

- stainless-steel pumps to avoid corrosion
- water hardness degree below 14 °dH and liquid temperature below 149 °F (65 °C) to eliminate the risk of lime precipitation.

## Pumping glycol mixtures

The product is designed for pumping water-glycol mixtures with up to 50 % glycol.

Example of a water-ethylene-glycol 50/50 mixture:

- Maximum viscosity: 10 cSt ~ 50 % water and 50 % ethylene-glycol at +14 °F (-10 °C).

Depending on the water-glycol mixture and the liquid temperature, the density and kinematic viscosity of the mixture will affect the maximum curve and reduce the hydraulic performance of the pump. The pump is protected against overload by an integrated power-limiting function.

1. Clean and flush the system before you add the water-glycol mixture.
2. Maintain the water-glycol mixture regularly to prevent corrosion or lime precipitation.
3. If further dilution of the supplied glycol is required, follow the glycol supplier's instructions.



To prevent the water-glycol mixture from degrading, minimize the operating time at high temperatures and avoid exceeding the rated liquid temperature.

## Sound pressure level

The sound pressure level of the pump is dependent on the power consumption. Levels are determined in accordance with ISO 3745 and ISO 11203, method Q2.

Pump size	Maximum dB(A)
25-40/60/80/100/120	39
32-40/60/80/100/120	
40-40/60	
50-40	
32-120 F	45
40-80/100	
50-60/80	
65-40/60	
80-40	
40-120/150/180	50
50-100/120/150/180	
65-80/100/120	
80-60/80	
100-40/60	55
65-150	
80-100/120	
100-80/100/120	

**Note:** Not all variants are available in all markets.

## Electrical data

<b>Pump type</b>	<b>MAGNA3 (D)</b>
<b>Enclosure class</b>	Type 2
<b>Insulation class</b>	F.
<b>Supply voltage</b>	1 x 115-230 V $\pm$ 10 %, 60 Hz*, PE. M20 cable gland (supplied with the pump).
<b>Three digital inputs</b>	External potential-free contact. Contact load: 5 V, 10 mA. Screened cable. M16 cable gland (not supplied with the pump). Loop resistance: Maximum 130 $\Omega$ .
<b>Analog input</b>	4-20 mA (load: 150 $\Omega$ ). 0-10 VDC (load: > 10 k $\Omega$ ).
<b>Two relay outputs</b>	Internal potential-free changeover contact. Maximum load: 250 V, 2 A, AC1. Minimum load: 5 VDC, 20 mA. Screened cable, depending on signal level. M16 cable gland (not supplied with the pump).
<b>Bus input</b>	Grundfos Communication Interface Modules (add-on CIM modules) for: <ul style="list-style-type: none"> <li>• GENIbus</li> <li>• LonWorks+</li> <li>• Modbus RTU</li> <li>• BACnet MS/TP</li> <li>• GSM/GPRS</li> <li>• Grundfos Remote Management</li> <li>• Ethernet.</li> </ul>
<b>Leakage current</b>	$I_{leakage} < 3.5$ mA. The leakage currents are measured in accordance with EN 60335-1.
<b>EMC</b>	Standards used: EN 55014-1:2006 + A1:2009 + A2:2011, EN 55014-1:2017, EN 61000-6-2:2005, EN 61000-3-3:2013, EN61000-3-2:2014.
<b>Cos <math>\phi</math></b>	Terminal-connected versions have a built-in active PFC (Power Factor Control) which gives a cos $\phi$ from 0.98 to 0.99, i.e. very close to 1. Wire-to-wire versions have no PFC and therefore the power factor is from 0.50 to 0.99.
<b>Consumption when the pump is stopped</b>	4 to 10 W, depending on activity, i.e. reading the display, use of Grundfos GO, interaction with modules, etc. 4 W, when the pump is stopped and there is no activity.

\* All MAGNA3 pumps are approved to run on both 50 and 60 Hz.

## 6. Construction

MAGNA3 is of the canned-rotor type, i.e. the pump and motor form an integral unit without shaft seal and with only two gaskets for sealing. The bearings are lubricated by the pumped liquid.

The pump is characterized by the following:

- controller integrated in the control box
- operating panel on the control box
- control box prepared for optional CIM modules
- built-in differential-pressure and temperature sensor
- cast-iron or stainless-steel pump housing
- twin-head versions
- no external motor protection required
- insulating shells supplied with single-head pumps for heating systems.

### Motor and electronic controller

MAGNA3 incorporates a 4-pole synchronous, permanent-magnet motor (PM motor). This motor type is characterized by higher efficiency than a conventional asynchronous squirrel-cage motor.

The pump speed is controlled by an integrated variable frequency drive.

### Differential-pressure and temperature sensor

The differential-pressure and temperature sensor is located in the pump housing in a channel between the inlet and outlet ports.

Via a cable, the sensor sends an electrical signal for the differential pressure across the pump and for the liquid temperature to the controller in the control box.

The sensor offers substantial benefits:

- direct feedback on the pump display
- complete pump control
- measurement of the pump workload for precise and optimum control resulting in higher energy efficiency.

### Sensor specifications, temperature

Temperature range during operation	Accuracy
14 to 95 °F (-10 to +35 °C)	± 4 °F (± 2 °C)
95 to 194 °F (35 to 90 °C)	± 2 °F (± 1 °C)
194 to 230 °F (90 to 110 °C)	± 4 °F (± 42 °C)

### Pump connections

Threaded pipe connections according to ISO 228-1.

Flange dimensions to EN 1092-2.

### Surface treatment

The pump housing and pump head are electrocoated to improve corrosion resistance.

Electrocoating includes:

- alkaline cleaning
- pretreatment with zinc phosphate coating
- cathodic electrocoating (epoxy)
- curing of paint film at 392 to 482 °F (200 to 250 °C).

The pump housing of stainless-steel versions is not treated or painted and appears in blank steel. See the figure below.



TM082060

MAGNA3 stainless steel version

### Color

Color codes for the pump:

Color	Code
Red	NCS40-50R
Black	NCS9000

## Sectional drawing

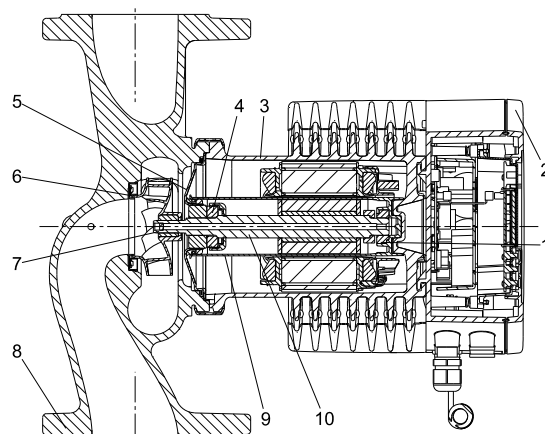

TM052319

*Terminal-connected version*

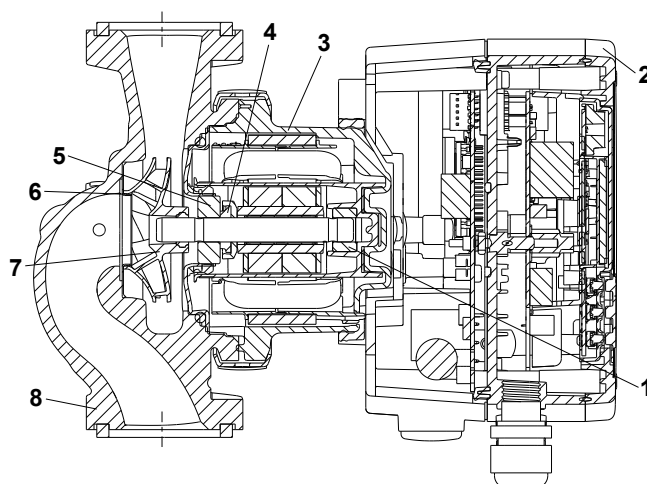

TM071970

*Wire-to-wire-connected version*

## Material specification

See section Sectional drawing.

Pos.	Component	Material	Grade
1	Outer bearing ring	Aluminium oxide	
2	Control box	Polycarbonate	
3	Stator housing	Aluminium	
	O-rings	EPDM	
4	Thrust bearing	Aluminium oxide/carbon	
5	Bearing plate	Stainless steel	AISI 304 (EN 1.4301)
6	Neck ring	Stainless steel	AISI 304 (EN 1.4301)
7	Impeller	PES	

Pos.	Component	Material	Grade
8	Pump housing	Cast iron/stainless steel	ASTM A48 class 35B/AISI 316 (EN 1561 EN-GJL-250/EN 1.4308)
9	Rotor can	PPS	
10	Shaft	Ceramic (wire-to-wire-connected versions)	
10	Shaft	Stainless steel (terminal-connected versions)	AISI 316L (EN 1.4404)

**Related information**[Sectional drawing](#)

## Sensor drawing

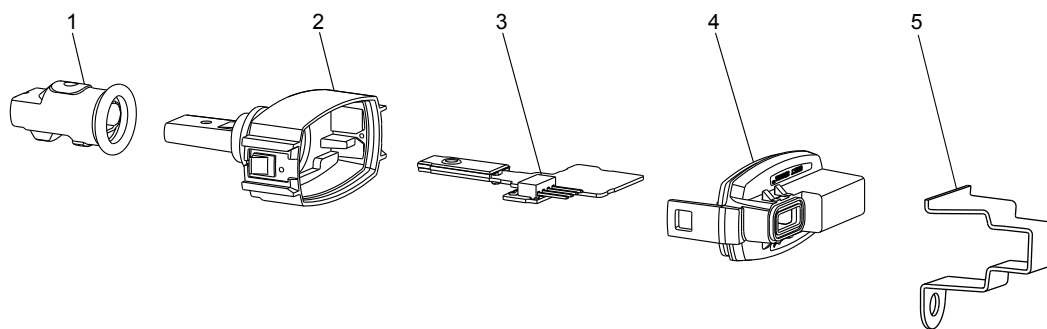

TM069250

### Sensor

Pos.	Component	Material	Grade
1	Sealing cap	EPDM	
2	Housing	PPS	
3	Printed-circuit board	-	
4	Cover snap-on	PA/TPV	
5	Bracket for sensor	Stainless steel	AISI 304 (EN 1.4301)

## 7. Installation

### Minimum clearance

The space required for installing and operating MAGNA pumps is illustrated below.

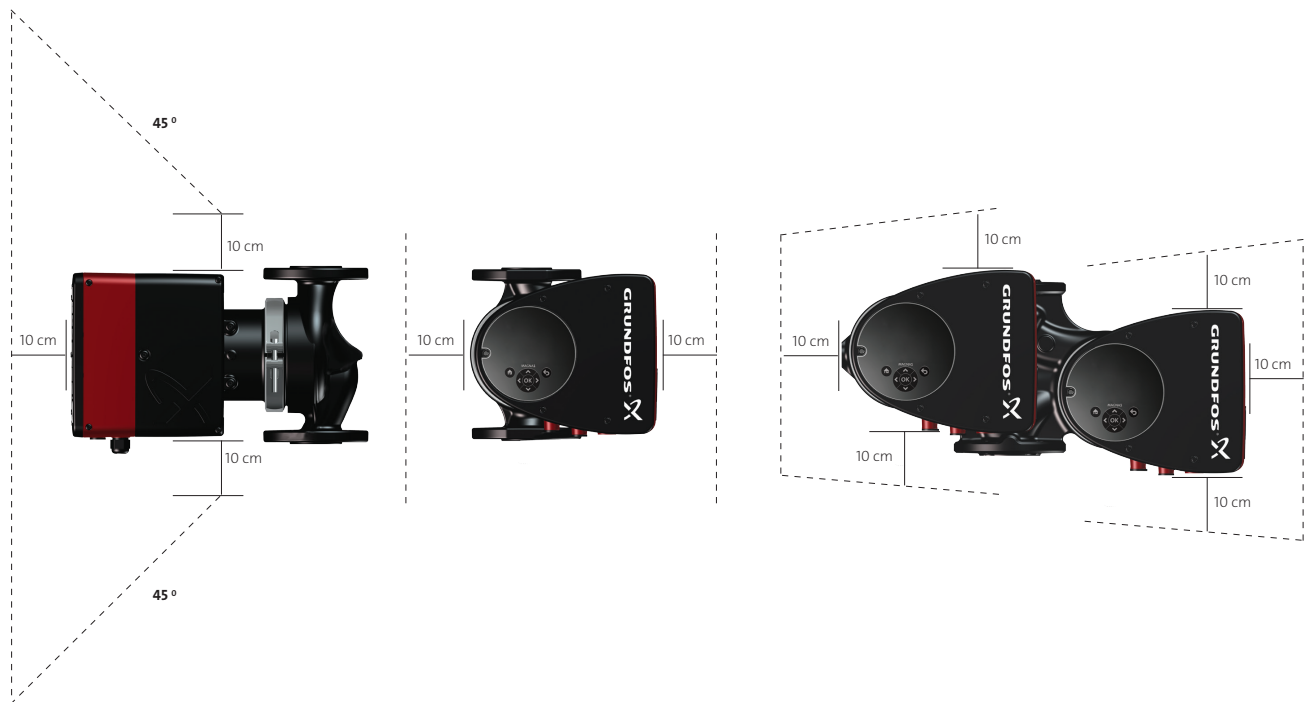

TM060058

*Minimum clearance required for single-head and twin-head pumps*

## Mechanical installation

MAGNA3 is designed for indoor installation.

You must install the pump with horizontal motor shaft.

You can install the pump in horizontal as well as vertical pipes.

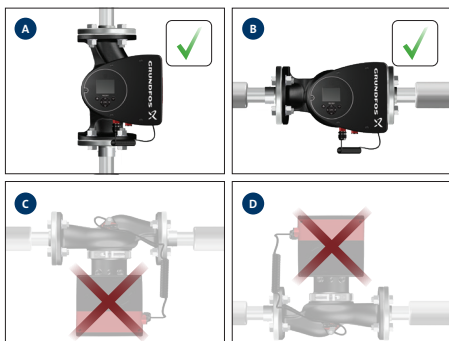

### Installation positions

Arrows on the pump housing indicate the liquid flow direction through the pump.

The control box must be in horizontal position with the Grundfos logo in vertical position. See figure above.

You must install the pump in such a way that it is not stressed by the pipes.

The pump may be suspended directly in the pipes, provided that the pipes can support the pump.

Twin-head pumps are prepared for installation on a mounting bracket or base plate.

To ensure adequate cooling of motor and electronics, observe the following:

- Position the pump in such a way that sufficient cooling is ensured.
- The temperature of the ambient air must not exceed 104 °F ° (40 °C).

### Insulating shells

The insulating shells supplied with single-head MAGNA3 pumps are for heating systems and must be fitted as part of the installation.

Insulating shells for applications with ice buildup are available as an accessory.

See section Insulating kits for applications with ice buildup.

**Note:** Insulating shells are not available for twin-head pumps.

Insulating shells increase the pump dimensions.

### Related information

[Insulating kits for applications with ice buildup](#)

## Electrical installation

The electrical connection and protection must be carried out in accordance with local regulations.

- The pump must be connected to an external main switch.
- The pump must always be correctly grounded.
- The pump requires no external motor protection.
- The pump incorporates thermal protection against slow overloading and blocking.
- When switched on via the power supply, the pump will start pumping after approximately 5 seconds.

**Note:** The number of starts and stops via the power supply must not exceed four times per hour.

The pump has a digital input that you can use for external control of start/stop without switching the power supply on and off.

Make the pump mains connection as shown in the diagrams on the following pages.

If rigid conduit is to be used, the hub must be connected to the conduit system before it is connected to the terminal box of the pump.

### Cables

Use screened cables for the external on and off switch, the digital input, sensor and setpoint signals.

All cables used must be heat-resistant up to at least 158 °F (70 °C.)

All cables used must be installed in accordance with the National Electrical Code, or in Canada, Canadian Electrical Code, and state and local regulations.

TM052866

**Additional protection**

**Ground fault circuit interrupter (GFCI)**

Use a suitable type of GFCI capable of handling ground fault currents with a DC content (pulsating DC). If the pump is connected to an electrical installation where a GFCI is used for additional protection, this GFCI must be able to trip when ground fault currents with DC content occur.

**Connection to power supply, terminal-connected versions**

**Example of a terminal-connected motor with main switch, backup fuse and additional protection**

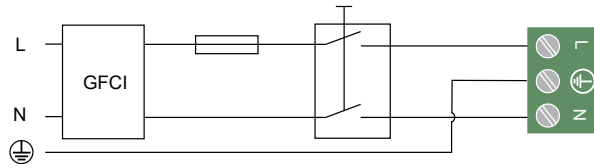

TM081460

**Example of electrical connections for models with wire-to-wire connections**

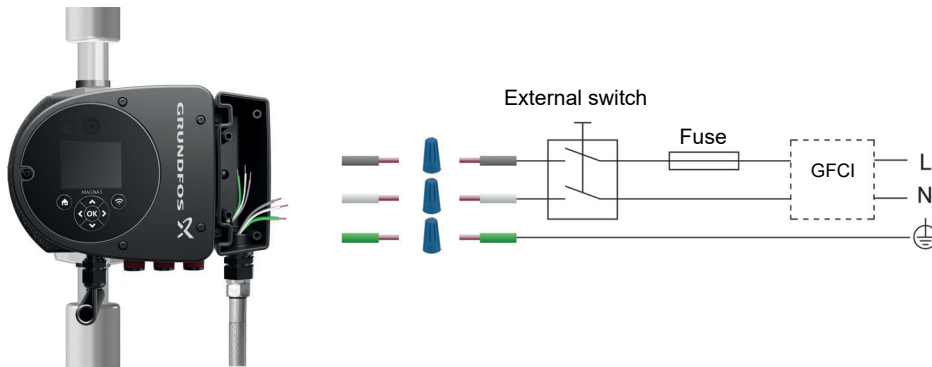

TM082068

### Example of connections in the control box of terminal-connected versions

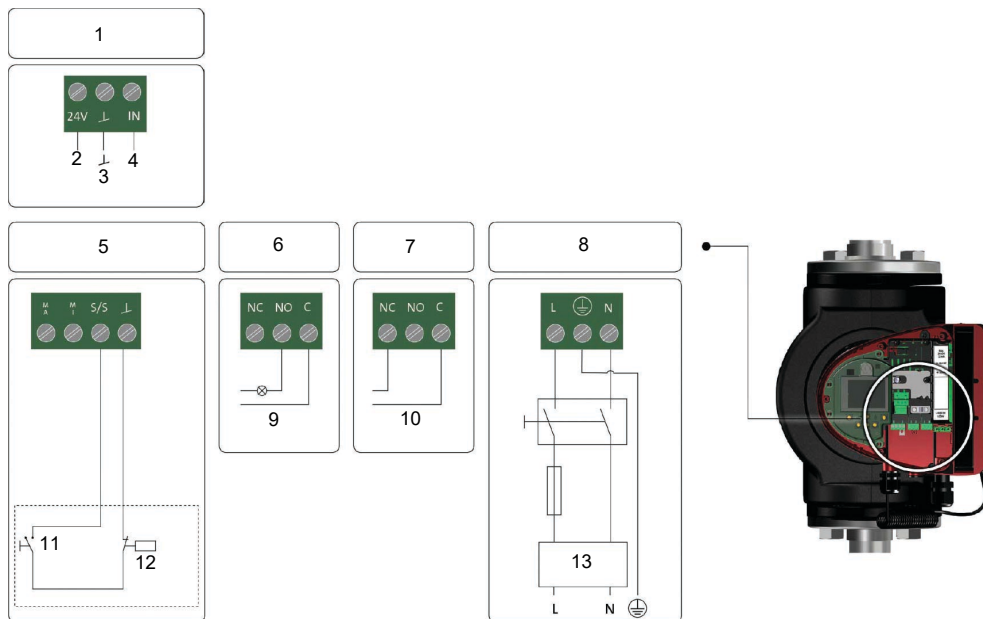

TM070364

Pos.	Description
1	Analog input
2	Vcc
3	Sensor
4	Signal
5	Digital input
6	Relay 1
7	Relay 2
8	Power
9	Operation
10	Alarm
11	Start/stop
12	On/off timer
13	13

Use C and NC for fault signals as this enables serial connections of more relays and detection of signal cable defects.

Example of connections in the control box of wire-to-wire connected versions

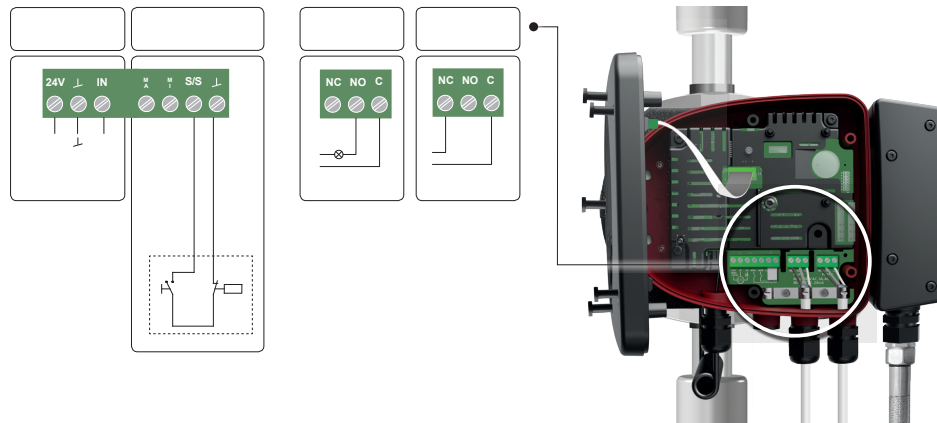

TM071623

Pos.	Description
1	Analog input
2	Digital input
3	Relay 1
4	Relay 2
5	Vcc
6	Sensor
7	Signal
8	Operation
9	Alarm

Use C and NC for fault signals as this enables serial connections of more relays and detection of signal cable defects

For further information on digital and analog inputs, see sections Digital inputs and Analog input for an external sensor. For information on relay outputs, see section Relay outputs.

For details on how to install and operate the MAGNA3 pumps, please see the Installation and operating instructions: <http://net.grundfos.com/qr/i/92662506>



QR92662506

**Related information**

[Digital inputs](#)

[Relay outputs](#)

[Analog input for an external sensor](#)

## 8. Operating the product

MAGNA3 can be operated and monitored via the operating panel on the pump and via the Grundfos GO app.

### Operating panel

The MAGNA3 pump range allows you to set the pump directly on the user-friendly, 4" TFT operating panel with self-explanatory push-buttons made of high-quality silicone for precise navigation.

The operating panel gives quick and easy access to pump and performance data on site. The menu includes all available MAGNA3 pump settings, such as control mode, setpoint, relay output and bus communication.

### Startup guide and assistance

When you start the pump for the first time, you are presented with a startup guide enabling easy setting of the pump. Additionally, the "Assist" menu, including the application wizard, guides you through the various settings of the pump.

### Application wizard

The application wizard helps you to set the correct control mode according to your application. The wizard can be accessed via the startup guide and the "Assist" menu.

Starting with the overall application type, e.g. radiator, and then specifying the system setup step by step, the wizard identifies the best suited control mode and, if necessary, helps you set the duty point.

The Display menu overview booklet provided with the pump includes application overviews such as the ones shown in section System applications. Using these, you can quickly identify the pump in your system and apply this knowledge directly to the wizard on the pump.

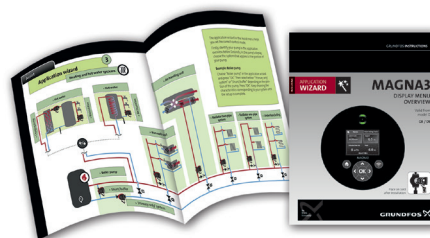

TM062080



TM063820

Operating panel, startup guide

## Grundfos GO

The Grundfos GO app includes assisted pump setup and assisted fault advice.

The MAGNA3 Model E pump communicates wirelessly with Grundfos GO via Bluetooth, which allows you to:

- read operating data such as flow rate, liquid temperature and energy consumption
- read out warnings and alarms
- set the control mode and setpoint
- select external setpoint signal
- select function for digital input
- set up multipump systems
- allocate the pump number making it possible to distinguish between pumps that are connected via Grundfos GENIbus
- generate pdf reports with operating data, pump setup and warnings and alarms history.

## Connecting to Grundfos GO via Bluetooth

The MAGNA3 pump communicates wirelessly with Grundfos GO via Bluetooth, which allows you to connect directly to the Grundfos GO app on your smart device without any need for a dongle.

Before connecting the product to Grundfos GO, download the Grundfos GO app to your smartphone or tablet. The app is free of charge and available for iOS and Android devices.

1. Open Grundfos GO on your device. Make sure that Bluetooth is enabled.  
Your device must be within reach of the product to establish Bluetooth connection.
2. Press the Bluetooth CONNECT button on Grundfos GO on your device.
3. Press the connect button on the operating panel of the pump. The center LED of Grundfos eye above the display is flashing until your device is connected. Once the connection is established, the LED will be permanently on.

Grundfos GO is now ready for setting up and monitoring the product.



TM082070

## 9. Curve conditions

### Performance curves

The guidelines below apply to the performance curves in sections Performance curves and technical data:

- Test liquid: airless water.
- The curves apply to a density of  $\rho = 983.2 \text{ kg/m}^3$  and a liquid temperature of 140 °F (60 °C).
- All curves show average values. If a specific minimum performance is required, individual measurements must be made.
- The curves apply to a kinematic viscosity of  $\mu = 0.474 \text{ mm}^2/\text{s}$  (0.474 cSt).
- Reference supply voltage: 1 x 230 V, 50 Hz.

**Note:** Within the MAGNA3 performance range, you can set the constant- and proportional-pressure curves in steps of 0.1 m head on the operating panel or with Grundfos GO.

### QR code on the pump nameplate





TM082051

*QR code on the pump nameplate*

With Grundfos GO or a smartphone, you get the following information about MAGNA3:

- product photo
- pump performance curves
- dimensional sketches
- wiring diagram
- quotation text
- technical data
- service parts list
- PDF files, such as data booklet and installation and operating instructions.

### Markings and approvals

Mark	Description
	Intertek - ETL Listed for USA and Canada <ul style="list-style-type: none"> <li>• Conforms to: ANSI/UL Std. 778</li> <li>• Certified to: CAN/CSA C22.2 No. 108</li> </ul>
	USA and Canada <p>Applies to pumps with stainless steel pump housing (flange).</p>
Drinking water system component, pump NSF/ANSI/CAN 61 NSF/ANSI/CAN 372	

## 10. Performance curves and technical data

### Conversion tables

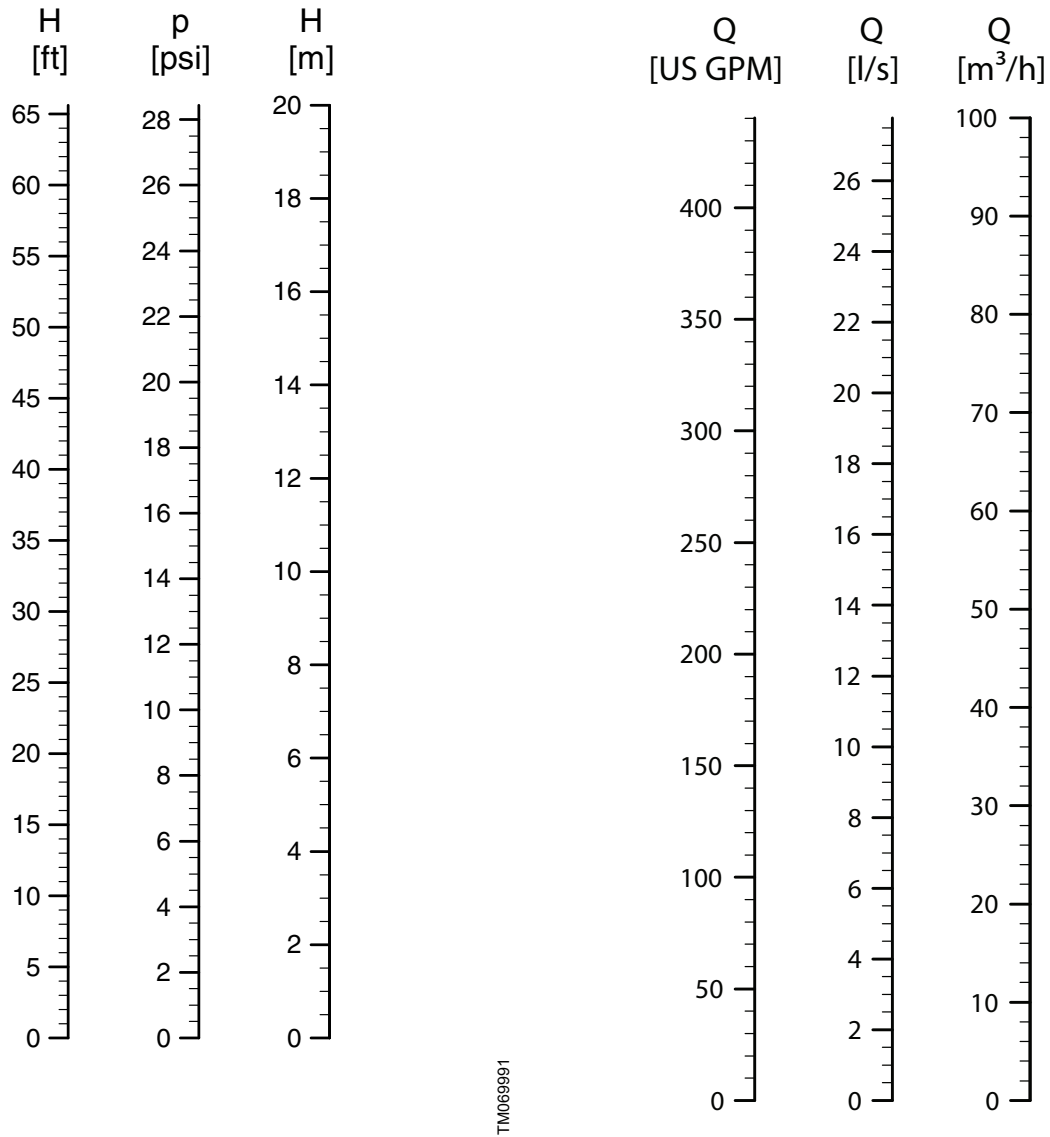

TM069991

TM069913

# MAGNA3 32-60 F (N)

1 x 115, 230 V, 60 Hz

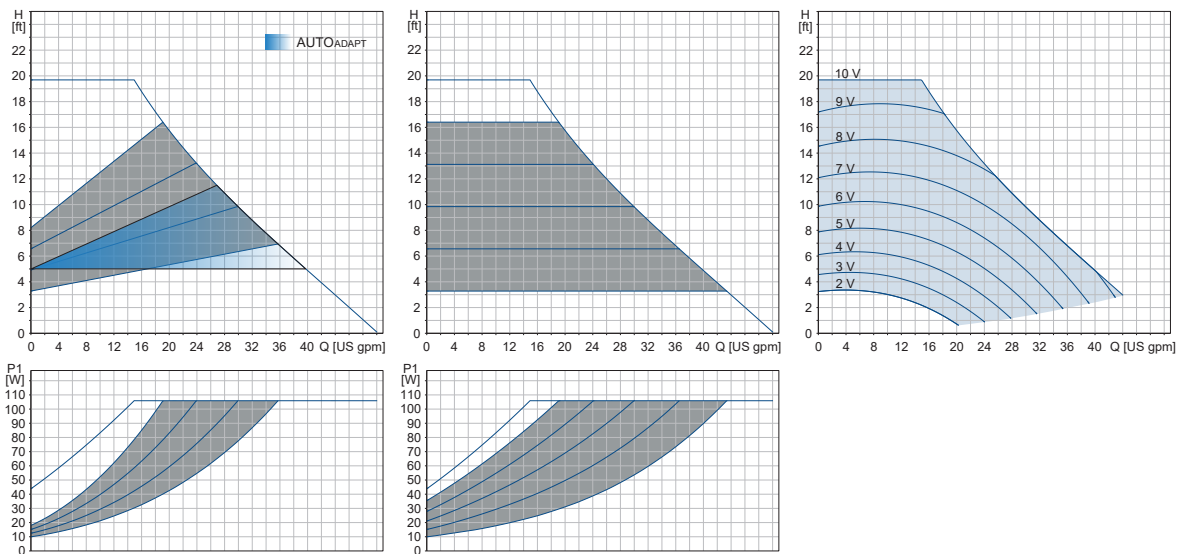

Speed	P1 [W] 115 V	I <sub>1</sub> [A] 115 V	P1 [W] 230 V	I <sub>1</sub> [A] 230 V
Min.	8.5	0.28	9	0.09
Max.	106	1.01	106	0.91

The pump incorporates overload protection.

Net weights [lb (kg)]	Ship. vol. [ft <sup>3</sup> (m <sup>3</sup> )]
13.2 (6.0)	0.76 (0.03)

Connections: GF15/26/40/43 flanges.  
See section Pipe connections.

System pressure: Max. 175 psi (1.2 MPa) (12 bar).

Liquid temperature: 14 to 230 °F (-10 to +110 °C) (TF 110).

Also available with: Stainless-steel pump housing, type N.

Specific EEI: 0.20 (115 V)  
0.19 (230 V)

\* External setpoint influence shown with a setpoint of H<sub>max</sub>

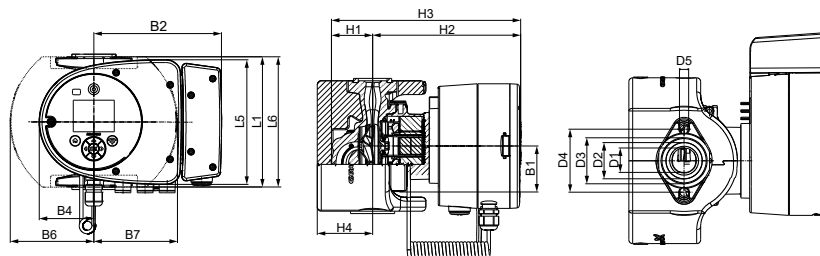

Pump type	Dimensions [inches (mm)]								
	L1	L5	L6	B1	B2	B4	B6	B7	D1
MAGNA3 32-60 F (N)	6.50 (165)	6.23 (158)	6.62 (168)	2.29 (58)	6.39 (162)	2.72 (69)	4.18 (106)	4.18 (106)	1.26 (32)
	D2	D3	D4	D5	H1	H2	H3	H4	
	1.82 (46)	2.29 (58)	3.15 (80)	0.46 (11.5)	2.13 (54)	7.37 (187)	9.49 (241)	2.76 (70)	

For product numbers, see section Product numbers.

## Related information

- [Pipe connections](#)
- [Single-head pumps](#)

# MAGNA3 32-100 F (N)

1 x 115, 230 V, 60 Hz

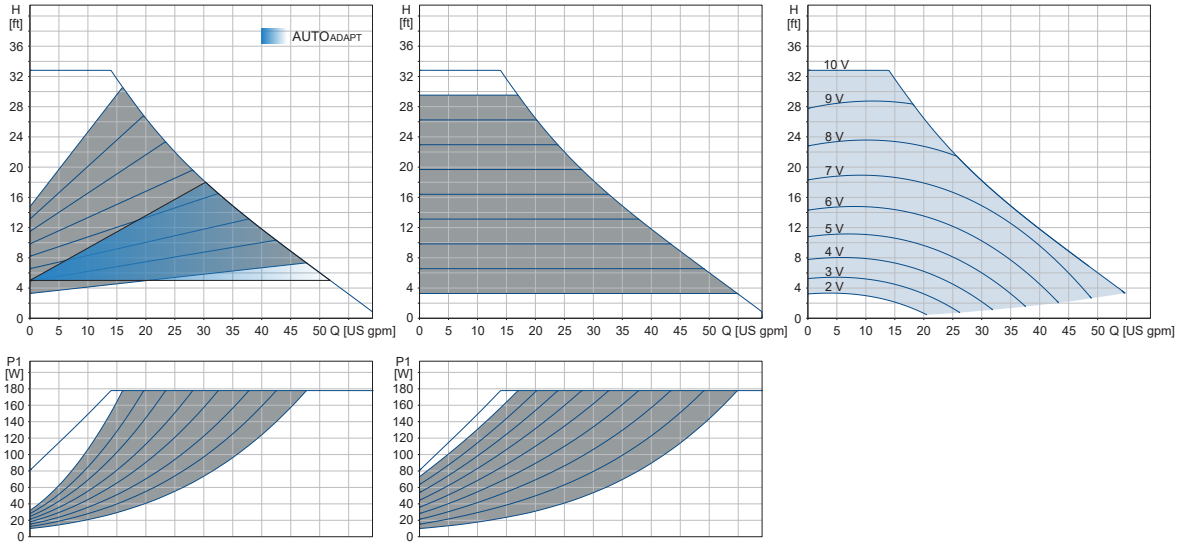

Speed	P1 [W]	I <sub>1</sub> [A]	P1 [W]	I <sub>1</sub> [A]
	115 V	115 V	230 V	230 V
Min.	9.7	0.29	9	0.09
Max.	178	1.61	178	1.47

The pump incorporates overload protection.

Net weights [lb (kg)]	Ship. vol. [ft <sup>3</sup> (m <sup>3</sup> )]
13.9 (6.3)	0.76 (0.03)

Connections: GF15/26/40/43 flanges.  
See section Pipe connections.

System pressure: Max. 175 psi (1.2 MPa) (12 bar).

Liquid temperature: 14 to 230 °F (-10 to +110 °C) (TF 110).

Also available with: Stainless-steel pump housing, type N.

Specific EEI: 0.20 (115 V)  
0.19 (230 V)

\* External setpoint influence shown with a setpoint of H<sub>max</sub>

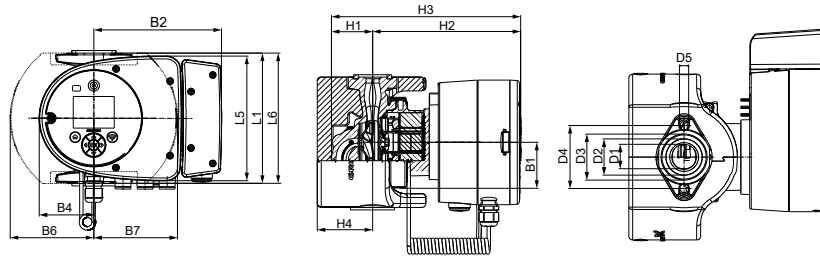

Pump type	Dimensions [inches (mm)]								
	L1	L5	L6	B1	B2	B4	B6	B7	D1
MAGNA3 32-100 F (N)	6.50 (165)	6.23 (158)	6.62 (168)	2.29 (58)	6.39 (162)	2.72 (69)	4.18 (106)	4.18 (106)	1.26 (32)
	D2	D3	D4	D5	H1	H2	H3	H4	
	1.82 (46)	2.29 (58)	3.15 (80)	0.46 (11.5)	2.13 (54)	7.37 (187)	9.49 (241)	2.76 (70)	

For product numbers, see section Product numbers.

### Related information

- [Pipe connections](#)
- [Single-head pumps](#)

TM081452

TM1040021

# MAGNA3 32-120 F (N)

1 x 115, 230 V, 60 Hz

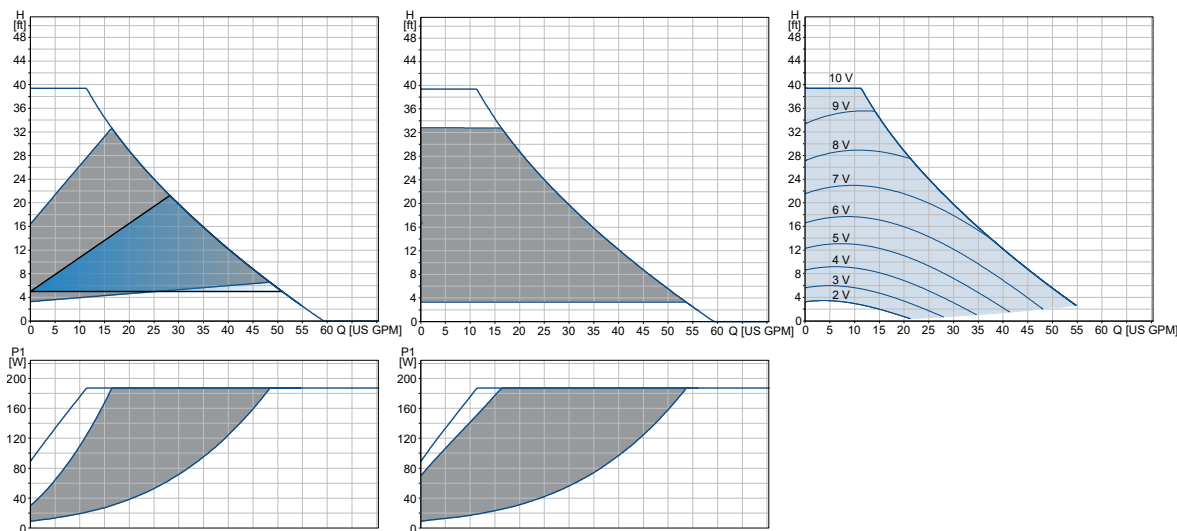

Speed	P1 [W]		I <sub>1</sub> [A]	
	115 V	230 V	115 V	230 V
Min.	9.1	9.1	0.12	0.17
Max.	187	187	1.67	0.83

The pump incorporates overload protection.

Net weights	Ship. vol.
[lb (kg)]	[ft <sup>3</sup> (m <sup>3</sup> )]
13.2 (6.0)	0.70 (0.020)

Connections: GF15/26/40/43 flanges.  
See section Pipe connections.

System pressure: Max. 175 psi (1.2 MPa) (12 bar).

Liquid temperature: 14 to 230 °F (-10 to +110 °C) (TF 110).

Also available with: Stainless-steel pump housing, type N.

Specific EEI: 0.20 (115 V)  
0.20 (230 V)

\* External setpoint influence shown with a setpoint of H<sub>max</sub>

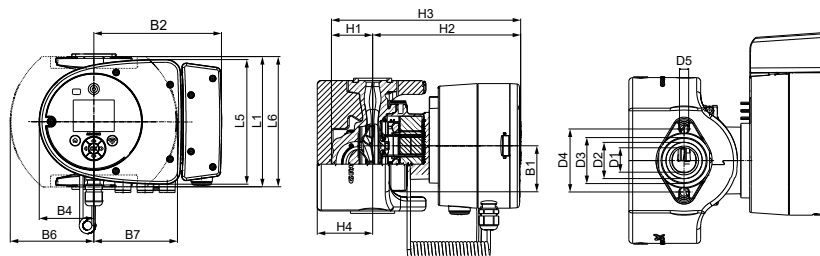

Pump type	Dimensions [inches (mm)]								
	L1	L5	L6	B1	B2	B4	B6	B7	D1
MAGNA3 32-120 F (N)	6.50 (165)	6.23 (158)	6.62 (168)	2.29 (58)	6.39 (162)	2.72 (69)	4.18 (106)	4.18 (106)	1.26 (32)
	D2	D3	D4	D5	H1	H2	H3	H4	
	1.82 (46)	2.29 (58)	3.15 (80)	0.46 (11.5)	2.13 (54)	7.37 (187)	9.49 (241)	2.76 (70)	

For product numbers, see section Product numbers.

## Related information

- [Pipe connections](#)
- [Single-head pumps](#)

# MAGNA3 40-80 F (N)

1 x 115, 230 V, 60 Hz

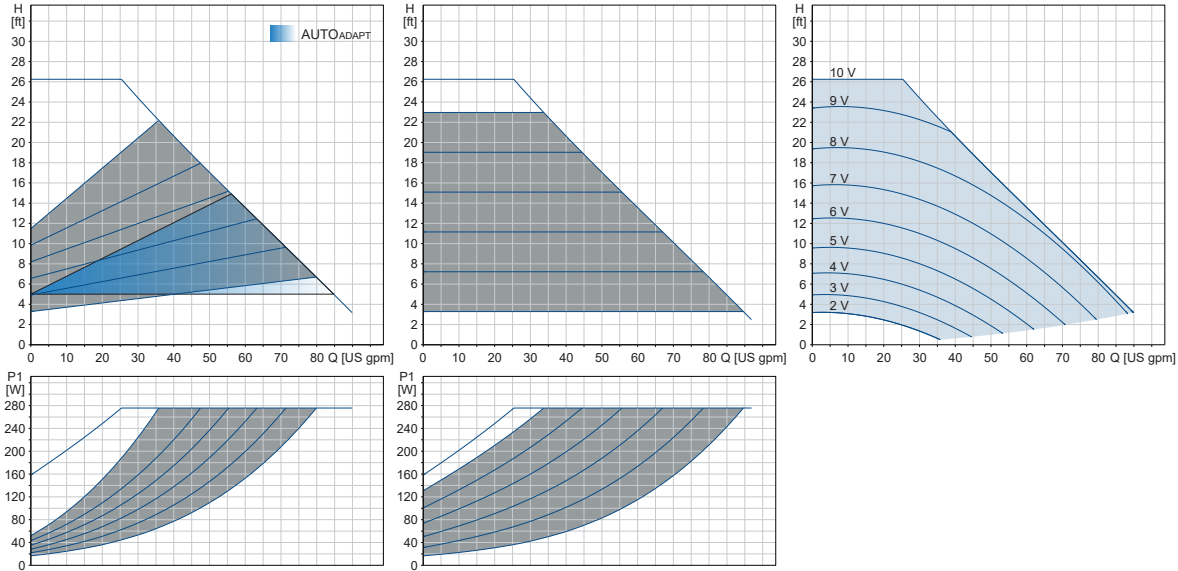

Speed	P1 [W]	I <sub>1</sub> [A]	P1 [W]	I <sub>1</sub> [A]
	115 V	115 V	230 V	230 V
Min.	16	0.30	16	0.19
Max.	285	2.57	274	1.33

The pump incorporates overload protection.

Net weights	Ship. vol.
[lb (kg)]	[ft <sup>3</sup> (m <sup>3</sup> )]
36.4 (16.5)	1.42 (0.04)

Connections: GF15/26/40/43 flanges.  
See section Pipe connections.

System pressure: Max. 175 psi (1.2 MPa) (12 bar).

Liquid temperature: 14 to 230 °F (-10 to +110 °C) (TF 110).

Also available with: Stainless-steel pump housing, type N.

Specific EEI: 0.20 (115 V)  
0.19 (230 V)

\* External setpoint influence shown with a setpoint of H<sub>max</sub>

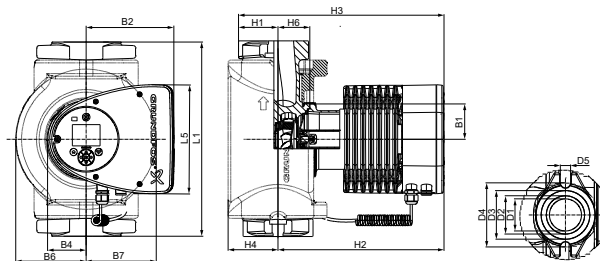

Pump type	Dimensions [in (mm)]								
	L1	L5	B1	B2	B4	B6	B7	D1	D2
MAGNA3 40-80 F (N)	8.5 (216)	8.03 (204)	3.31 (84)	6.46 (164)	2.87 (73)	4.37 (111)	4.37 (111)	1.57 (40)	1.93 (49)
	D3	D4	D5	H1	H2	H3	H4	H6	
	2.4 (60)	3.15 (80)	0.5 (12.8)	1.46 (37)	11.97 (304)	13.3 (338)	2.76 (70)	1.97 (50)	

For product numbers, see section Product numbers.

### Related information

- [Pipe connections](#)
- [Single-head pumps](#)

TM081454

TM1040022

# MAGNA3 40-120 F (N)

1 x 115, 230 V, 60 Hz

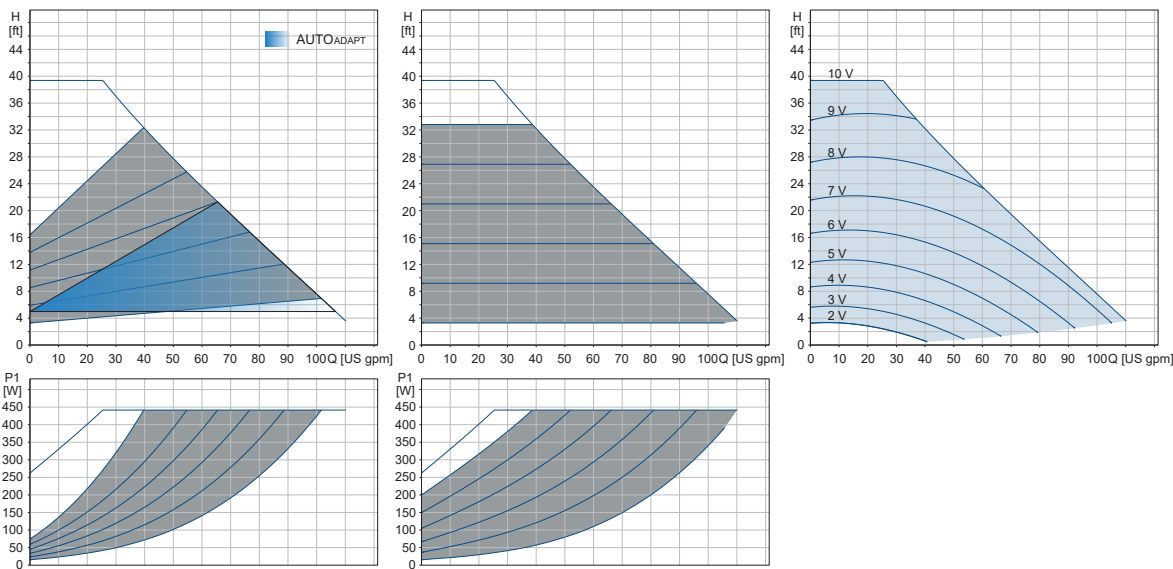

Speed	P1 [W]	I <sub>1</sub> [A]	P1 [W]	I <sub>1</sub> [A]
	115 V	115 V	230 V	230 V
Min.	16	0.26	16	0.19
Max.	448	3.96	440	2.00

The pump incorporates overload protection.

Net weights [lb (kg)]	Ship. vol. [ft <sup>3</sup> (m <sup>3</sup> )]
35.8 (16.2)	1.42 (0.04)

\* External setpoint influence shown with a setpoint of H<sub>max</sub>

Connections:

GF15/26/40/43 flanges.  
See section Pipe connections.

System pressure:

Max. 175 psi (1.2 MPa) (12 bar).

Liquid temperature:

14 to 230 °F (-10 to +110 °C) (TF 110).

Also available with:

Stainless-steel pump housing, type N.

Specific EEI:

0.19 (115V)  
0.19 (230V)

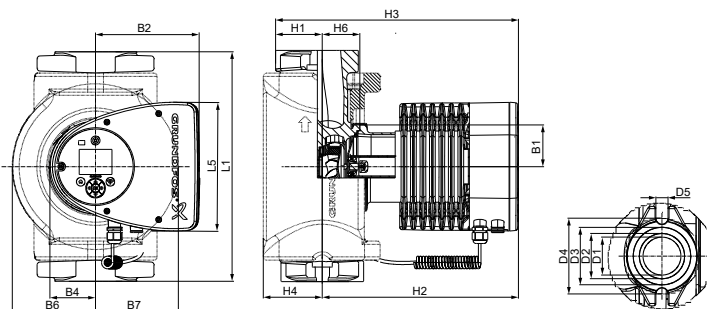

Pump type	Dimensions [in (mm)]								
	L1	L5	B1	B2	B4	B6	B7	D1	D2
MAGNA3 40-120 F (N)	8.5 (216)	8.03 (204)	3.31 (84)	6.46 (164)	2.87 (73)	4.37 (111)	4.37 (111)	1.57 (40)	1.93 (49)
	D3	D4	D5	H1	H2	H3	H4	H6	
	2.4 (60)	3.15 (80)	0.5 (12.8)	1.46 (37)	11.97 (304)	13.3 (338)	2.76 (70)	1.97 (50)	

For product numbers, see section Product numbers.

## Related information

[Pipe connections](#)

[Single-head pumps](#)

# MAGNA3 40-180 F (N)

1 x 115, 230 V, 60 Hz

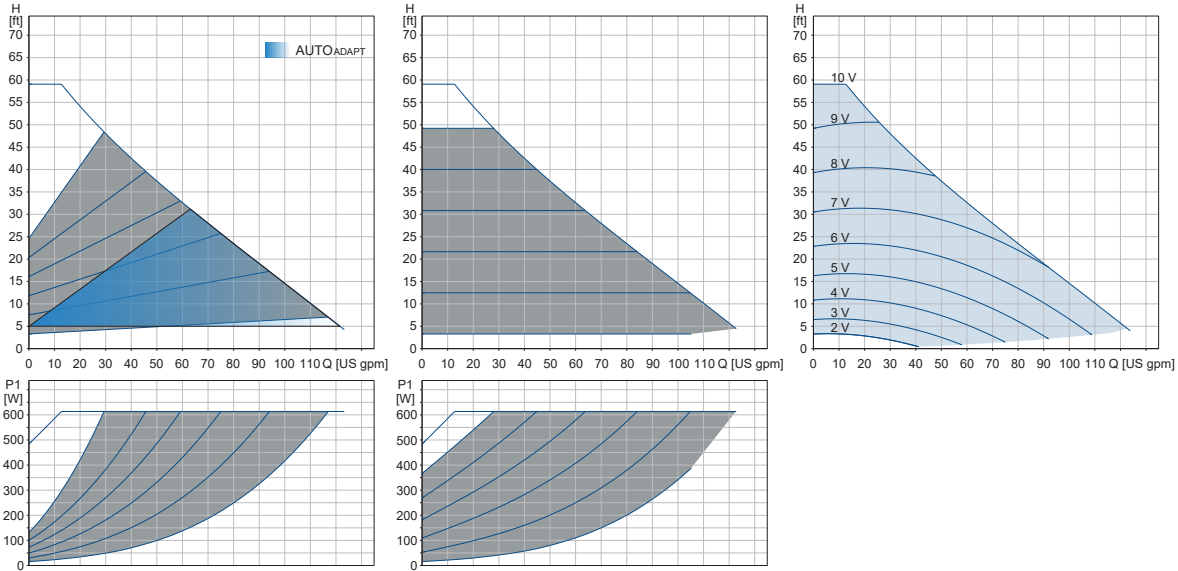

TM081456

Speed	P1 [W] 115 V	I <sub>1</sub> [A] 115 V	P1 [W] 230 V	I <sub>1</sub> [A] 230 V
Min.	16	0.26	16	0.18
Max.	606	5.26	600	2.65

The pump incorporates overload protection.

Net weights [lb (kg)]	Ship. vol. [ft <sup>3</sup> (m <sup>3</sup> )]
35.8 (16.2)	1.42 (0.04)

\* External setpoint influence shown with a setpoint of H<sub>max</sub>

- Connections: GF15/26/40/43 flanges. See section Pipe connections.
- System pressure: Max. 175 psi (1.2 MPa) (12 bar).
- Liquid temperature: 14 to 230 °F (-10 to +110 °C) (TF 110).
- Also available with: Stainless-steel pump housing, type N.
- Specific EEI: 0.18 (115V)  
0.19 (230V)

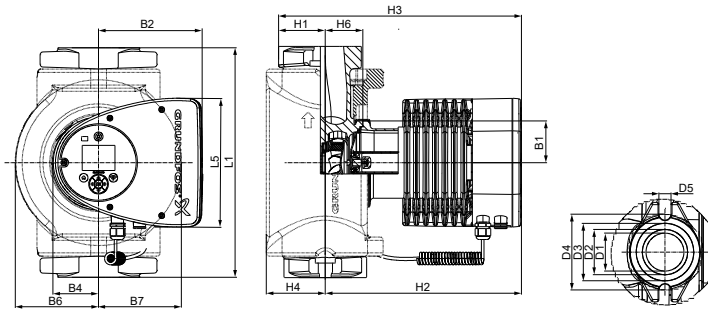

TM1040022

Pump type	Dimensions [in (mm)]								
	L1	L5	B1	B2	B4	B6	B7	D1	D2
MAGNA3 40-180 F (N)	8.5 (216)	8.03 (204)	3.31 (84)	6.46 (164)	2.87 (73)	4.37 (111)	4.37 (111)	1.57 (40)	1.93 (49)
	D3	D4	D5	H1	H2	H3	H4	H6	
	2.4 (60)	3.15 (80)	0.5 (12.8)	1.46 (37)	11.97 (304)	13.3 (338)	2.76 (70)	1.97 (50)	

For product numbers, see section Product numbers.

## Related information

- [Pipe connections](#)
- [Single-head pumps](#)

# MAGNA3 50-80 F (N)

1 x 115, 230 V, 60 Hz

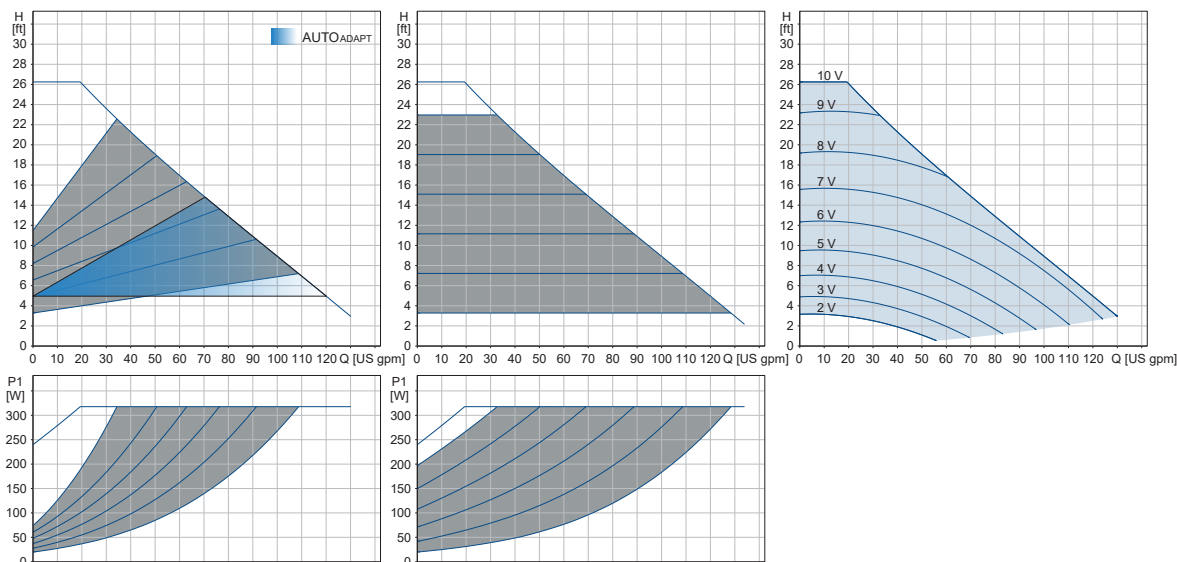

TM081457

Speed	P1 [W] 115 V	I <sub>1</sub> [A] 115 V	P1 [W] 230 V	I <sub>1</sub> [A] 230 V
Min.	18.5	0.31	18.5	0.22
Max.	341	3.09	330	1.58

The pump incorporates overload protection.

Net weights [lb (kg)]	Ship. vol. [ft <sup>3</sup> (m <sup>3</sup> )]
39.3 (17.8)	1.77 (0.05)

\* External setpoint influence shown with a setpoint of H<sub>max</sub>

Connections:

GF53 flanges.  
See section Pipe connections.

System pressure:

Max. 175 psi (1.2 MPa) (12 bar).

Liquid temperature:

14 to 230 °F (-10 to +110 °C) (TF 110).

Also available with:

Stainless-steel pump housing, type N.

Specific EEI:

0.19 (115V)  
0.18 (230V)

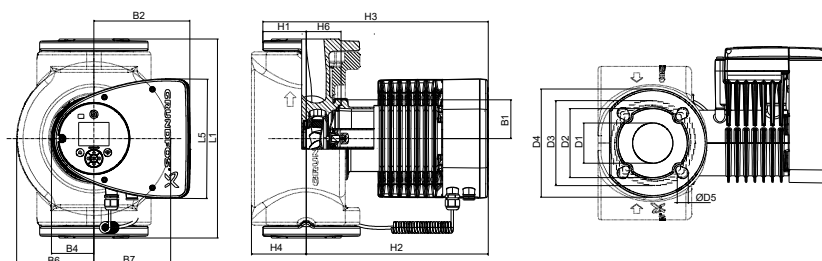

TM1040023

Pump type	Dimensions [in (mm)]								
	L1	L5	B1	B2	B4	B6	B7	D1	D2
MAGNA3 50-80 F (N)	9.45 (240)	8.03 (204)	3.31 (84)	6.46 (164)	2.87 (73)	5 (127)	5 (127)	1.97 (50)	3.90 (99)
	D3	D4	D5	H1	H2	H3	H4	H6	
	4.33/4.92 (110/125)	6.5 (165)	0.55/0.75 (14/19)	2.8 (71)	12.05 (306)	14.84 (377)	3.82 (97)	2.05 (52)	

For product numbers, see section Product numbers.

## Related information

[Pipe connections](#)

[Single-head pumps](#)

# MAGNA3 50-120 F (N)

1 x 115, 230 V, 60 Hz

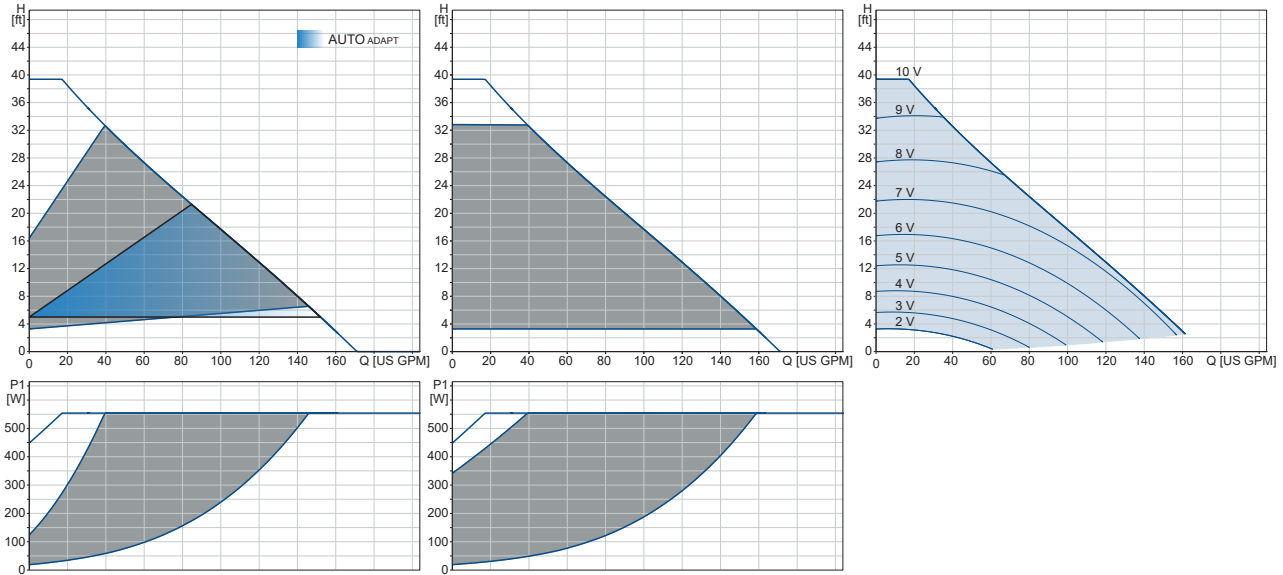

TM077900

Speed	P1 [W] 115 V	I <sub>1</sub> [A] 115 V	P1 [W] 230 V	I <sub>1</sub> [A] 230 V
Min.	20.7	0.37	20.3	0.23
Max.	554	4.85	553	2.47

The pump incorporates overload protection.

Net weights [lb (kg)]	Ship. vol. [ft <sup>3</sup> (m <sup>3</sup> )]
39.68 (18.0)	0.74 (0.021)

\* External setpoint influence shown with a setpoint of H<sub>max</sub>

Connections:

GF53 flanges.  
See section Pipe connections.

System pressure:

Max. 175 psi (1.2 MPa) (12 bar).

Liquid temperature:

14 to 230 °F (-10 to +110 °C) (TF 110).

Also available with:

Stainless-steel pump housing, type N.

Specific EEI:

0.19 (115V)  
0.18 (230V)

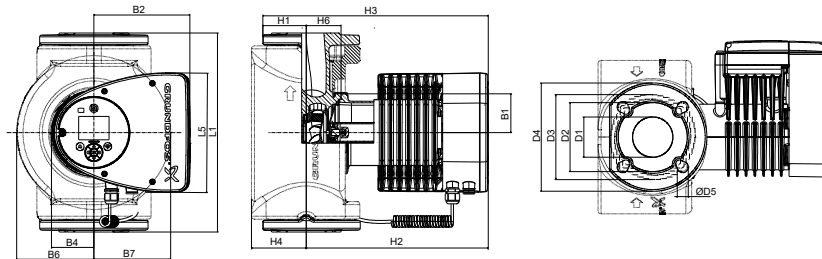

TM1040023

Pump type	Dimensions [in (mm)]								
	L1	L5	B1	B2	B4	B6	B7	D1	D2
MAGNA3 50-120 F (N)	11.02 (280)	8.03 (204)	3.31 (84)	6.46 (164)	2.87 (73)	5 (127)	5 (127)	1.97 (50)	3.90 (99)
	D3	D4	D5	H1	H2	H3	H4	H6	
	4.33/4.92 (110/125)	6.5 (165)	0.55/0.75 (14/19)	2.83 (72)	12.05 (306)	14.9 (378)	3.82 (97)	2.05 (52)	

For product numbers, see section Product numbers.

## Related information

[Pipe connections](#)

[Single-head pumps](#)

# MAGNA3 50-150 F (N)

1 x 115, 230 V, 60 Hz

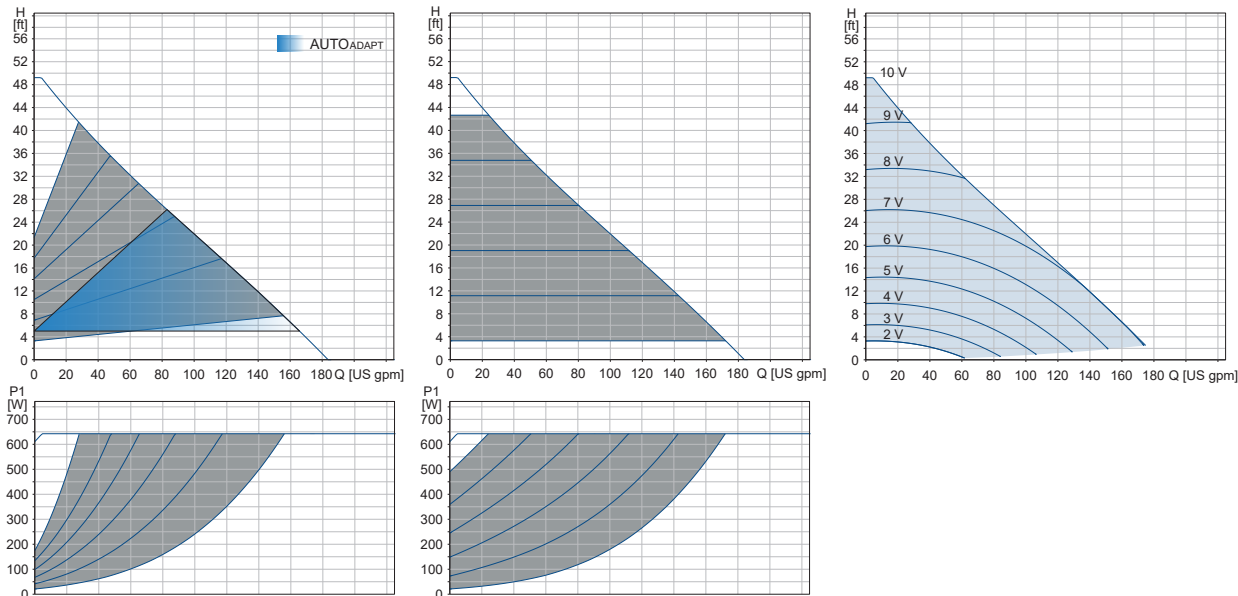

TM081459

Speed	P1 [W] 115 V	I <sub>1</sub> [A] 115 V	P1 [W] 230 V	I <sub>1</sub> [A] 230 V
Min.	18.5	0.31	18.5	0.23
Max.	643	5.69	598	2.87

The pump incorporates overload protection.

Net weights [lb (kg)]	Ship. vol. [ft <sup>3</sup> (m <sup>3</sup> )]
42.2 (19.1)	1.77 (0.05)

\* External setpoint influence shown with a setpoint of H<sub>max</sub>

Connections:

GF53 flanges.  
See section Pipe connections.

System pressure:

Max. 175 psi (1.2 MPa) (12 bar).

Liquid temperature:

14 to 230 °F (-10 to +110 °C) (TF 110).

Also available with:

Stainless-steel pump housing, type N.

Specific EEI:

0.18 (115V)  
0.17(230V)

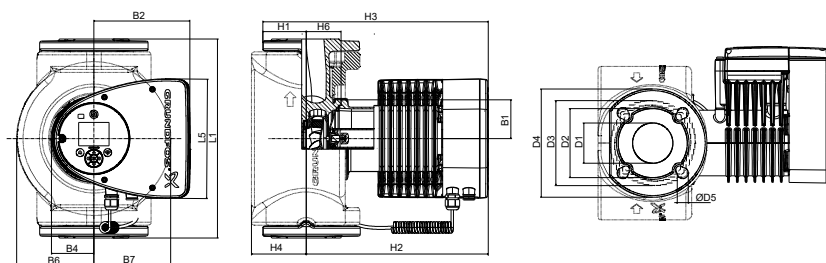

TM1040023

Pump type	Dimensions [in (mm)]								
	L1	L5	B1	B2	B4	B6	B7	D1	D2
MAGNA3 50-150 F (N)	11.02 (280)	8.03 (204)	3.31 (84)	6.46 (164)	2.87 (73)	5 (127)	5 (127)	1.97 (50)	3.90 (99)
	D3	D4	D5	H1	H2	H3	H4	H6	
	4.33/4.92 (110/125)	6.5 (165)	0.55/0.75 (14/19)	2.83 (72)	12.05 (306)	14.9 (378)	3.82 (97)	2.05 (52)	

For product numbers, see section Product numbers.

### Related information

[Pipe connections](#)

[Single-head pumps](#)

# MAGNA3 50-180 F (N)

1 x 115, 230 V, 60 Hz

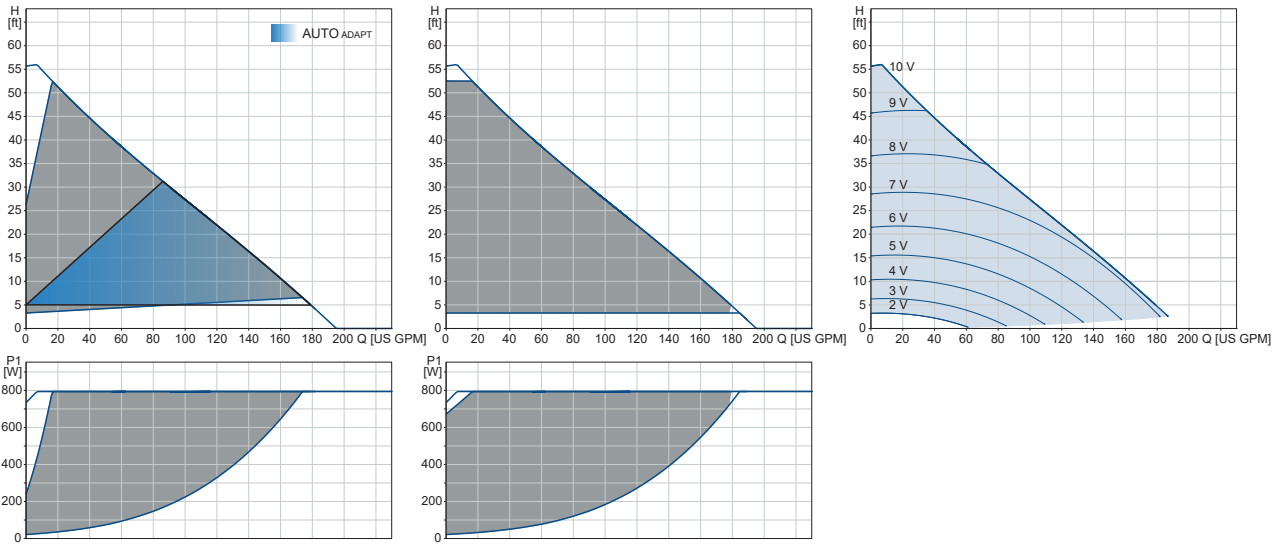

TM077901

Speed	P1 [W] 115 V	I <sub>1</sub> [A] 115 V	P1 [W] 230 V	I <sub>1</sub> [A] 230 V
Min.	21.8	0.39	22.5	0.24
Max.	794	6.96	755	3.33

The pump incorporates overload protection.

Net weights [lb (kg)]	Ship. vol. [ft <sup>3</sup> (m <sup>3</sup> )]
44.1 (20)	1.77 (0.05)

\* External setpoint influence shown with a setpoint of H<sub>max</sub>

Connections:	GF53 flanges. See section Pipe connections.
System pressure:	Max. 175 psi (1.2 MPa) (12 bar).
Liquid temperature:	14 to 230 °F (-10 to +110 °C) (TF 110).
Also available with:	Stainless-steel pump housing, type N.
Specific EEI:	0.19 (115V) 0.18 (230V)

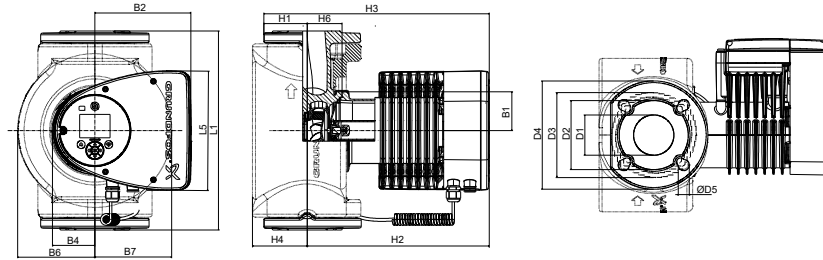

TM1040023

Pump type	Dimensions [in (mm)]								
	L1	L5	B1	B2	B4	B6	B7	D1	D2
MAGNA3 50-180 F (N)	11.02 (280)	8.03 (204)	3.31 (84)	6.46 (164)	2.87 (73)	5 (127)	5 (127)	1.97 (50)	3.90 (99)
	D3	D4	D5	H1	H2	H3	H4	H6	
	4.33/4.92 (110/125)	6.5 (165)	0.55/0.75 (14/19)	2.83 (72)	12.05 (306)	14.9 (378)	3.82 (97)	2.05 (52)	

For product numbers, see section Product numbers.

## Related information

[Pipe connections](#)

[Single-head pumps](#)

# MAGNA3 65-120 F (N)

1 x 115, 230 V, 60 Hz

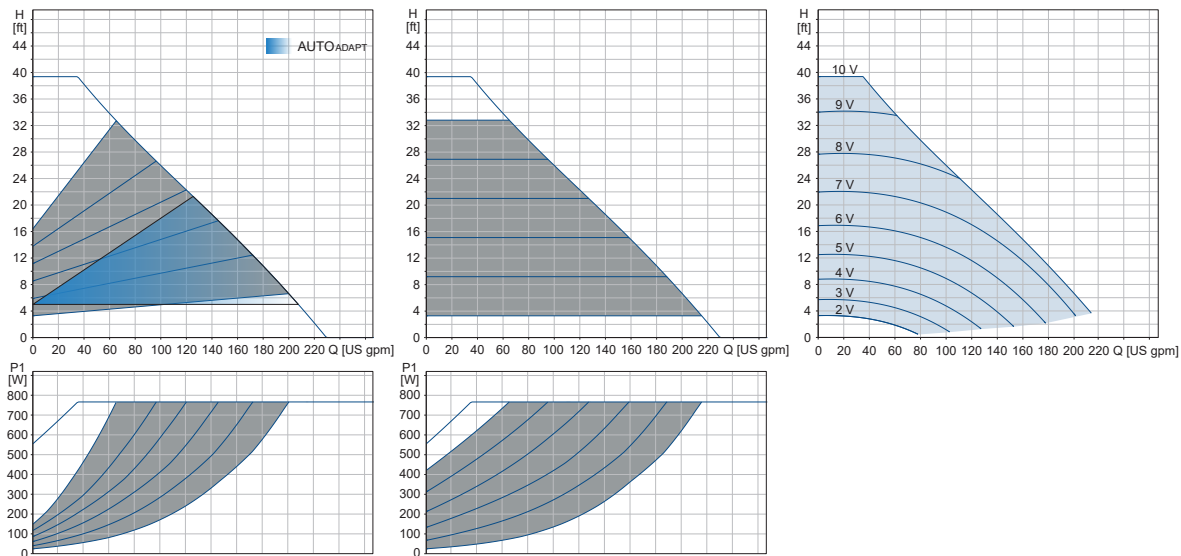

TM081461

Speed	P1 [W] 115 V	I <sub>1</sub> [A] 115 V	P1 [W] 230 V	I <sub>1</sub> [A] 230 V
Min.	20.5	0.36	0.18	20.5
Max.	767	6.75	758	3.32

The pump incorporates overload protection.

Net weights [lb (kg)]	Ship. vol. [ft <sup>3</sup> (m <sup>3</sup> )]
47.4 (21.5)	2.12 (0.06)

\* External setpoint influence shown with a setpoint of H<sub>max</sub>

- Connections: GF53/65 flanges. See section Pipe connections.
- System pressure: Max. 175 psi (1.2 MPa) (12 bar).
- Liquid temperature: 14 to 230 °F (-10 to +110 °C) (TF 110).
- Also available with: Stainless-steel pump housing, type N.
- Specific EEI: 0.17 (115V), 0.17 (230V)

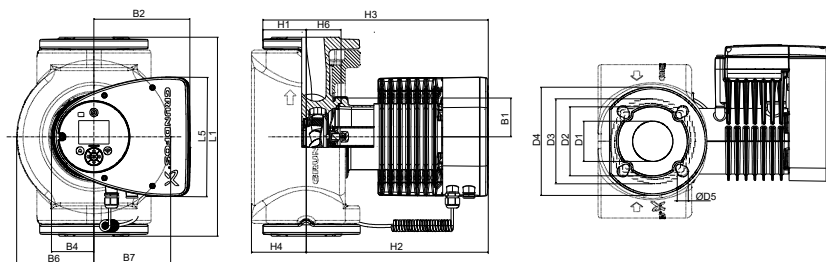

TM1040023

Pump type	Dimensions [in (mm)]								
	L1	L5	B1	B2	B4	B6	B7	D1	D2
MAGNA3 65-120 F (N)	13.4 (340)	8.03 (204)	3.31 (84)	6.46 (164)	2.87 (73)	5.24 (133)	5.24 (133)	2.56 (65)	4.65 (118)
	D3	D4	D5	H1	H2	H3	H4	H6	
	5.0/5.51 (127/140)	7.28 (185)	0.63/0.75 (16/19)	2.91 (74)	12.28 (312)	15.2 (386)	3.7 (94)	2.32 (59)	

For product numbers, see section Product numbers.

## Related information

- [Pipe connections](#)
- [Single-head pumps](#)

# MAGNA3 65-150 F (N)

1 x 230 V, 60 Hz

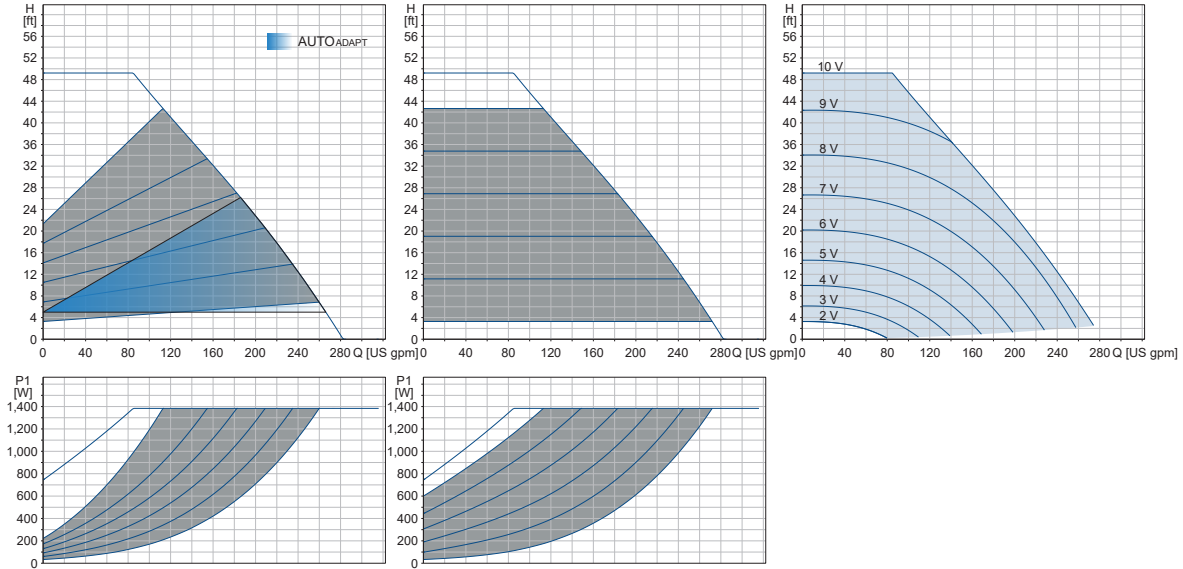

TM081462

Speed	P1 [W] 230 V	I <sub>1</sub> [A] 230 V
Min.	31	0.32
Max.	1385	6.10

The pump incorporates overload protection.

Net weights [lb (kg)]	Ship. vol. [ft <sup>3</sup> (m <sup>3</sup> )]
66.2 (30.0)	2.12 (0.06)

\* External setpoint influence shown with a setpoint of H<sub>max</sub>

- Connections: GF53/65 flanges.  
See section Pipe connections.
- System pressure: Max. 175 psi (1.2 MPa) (12 bar).
- Liquid temperature: 14 to 230 °F (-10 to +110 °C) (TF 110).
- Also available with: Stainless-steel pump housing, type N.
- Specific EEI: 0.17.

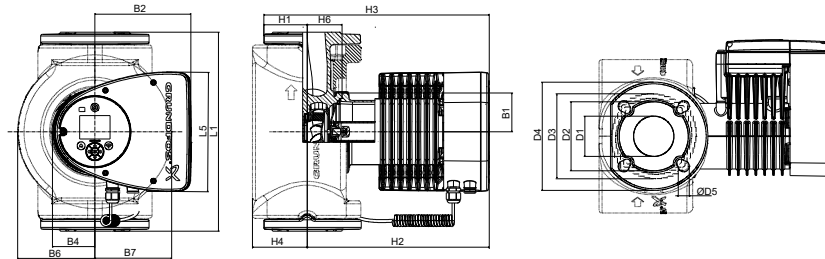

TM1040023

Pump type	Dimensions [in (mm)]								
	L1	L5	B1	B2	B4	B6	B7	D1	D2
MAGNA3 65-150 F (N)	13.4 (340)	8.03 (204)	3.31 (84)	6.46 (164)	2.87 (73)	5.24 (133)	5.24 (133)	2.56 (65)	4.65 (118)
	D3	D4	D5	H1	H2	H3	H4	H6	
	5.0/5.51 (127/140)	7.28 (185)	0.63/0.75 (16/19)	2.91 (74)	12.28 (312)	15.2 (386)	3.7 (94)	2.32 (59)	

For product numbers, see section Product numbers.

## Related information

- [Pipe connections](#)
- [Single-head pumps](#)

# MAGNA3 D 65-150 F

1 x 230 V, 60 Hz

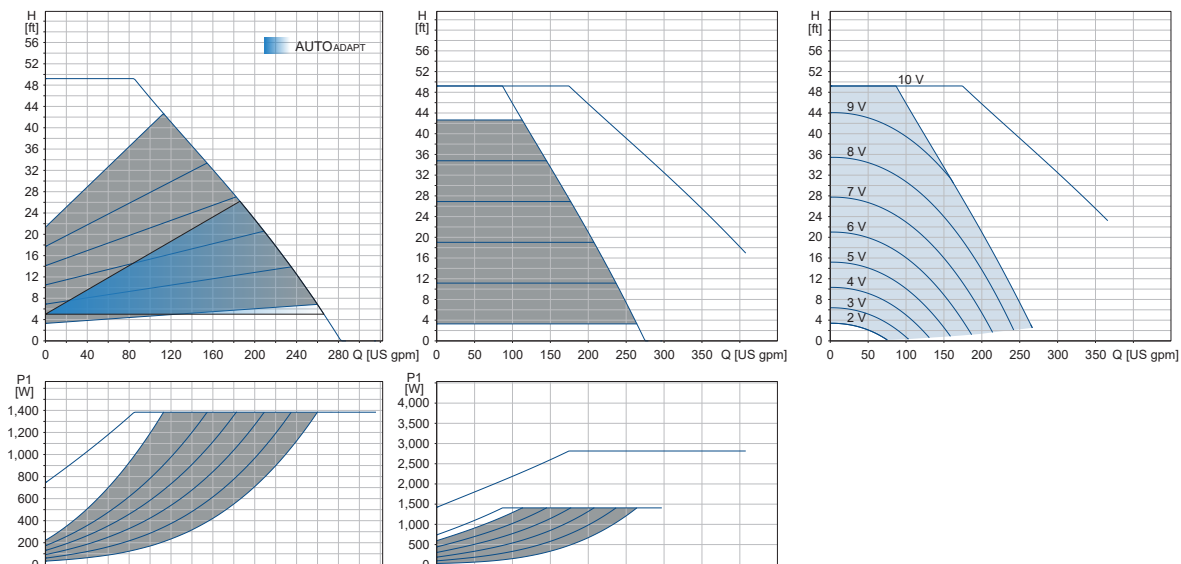

Speed	P1 [W] 230 V	I <sub>1</sub> [A] 230 V
Min.	29	0.30
Max.	1409	6.18

The pump incorporates overload protection.

Net weights [lb (kg)]	Ship. vol. [ft <sup>3</sup> (m <sup>3</sup> )]
101 (45.8)	2.12 (0.06)

\* External setpoint influence shown with a setpoint of H<sub>max</sub>

Connections:

GF53/65 flanges.  
See section Pipe connections.

System pressure:

Max. 175 psi (1.2 MPa) (12 bar).

Liquid temperature:

14 to 230 °F (-10 to +110 °C) (TF 110).

Specific EEI:

0.17.

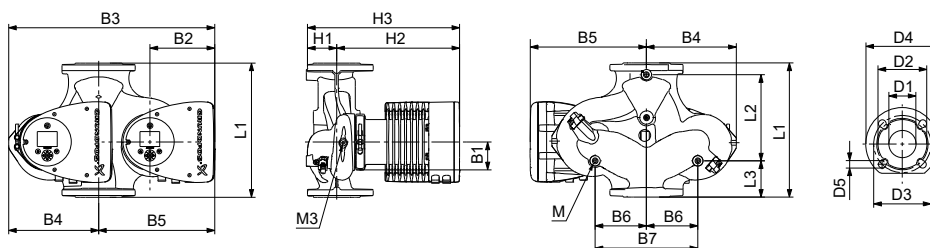

Pump type	Dimensions [in (mm)]								
	L1	L2	L3	L4	L5	B1	B3	B4	B5
MAGNA3 D 65-150 F	13.4 (340)	8.58 (218)	3.62 (92)	3.62 (92)	8.03 (204)	3.31 (84)	20.55 (522)	8.98 (228)	11.57 (294)
	D1	D2	D3	D4	D5	D5 (2)	M	M1	H1
	2.56 (65)	4.69 (119)	5.12/5.71 (130/145)	7.28 (185)	0.55 (14)	0.75 (19)	M12	Rp 1/4	3.03 (77)

For product numbers, see section Product numbers.

## Related information

[Pipe connections](#)

[Single-head pumps](#)

TM081463

TM1040020

# MAGNA3 80-100 F (N)

1 x 230 V, 60 Hz

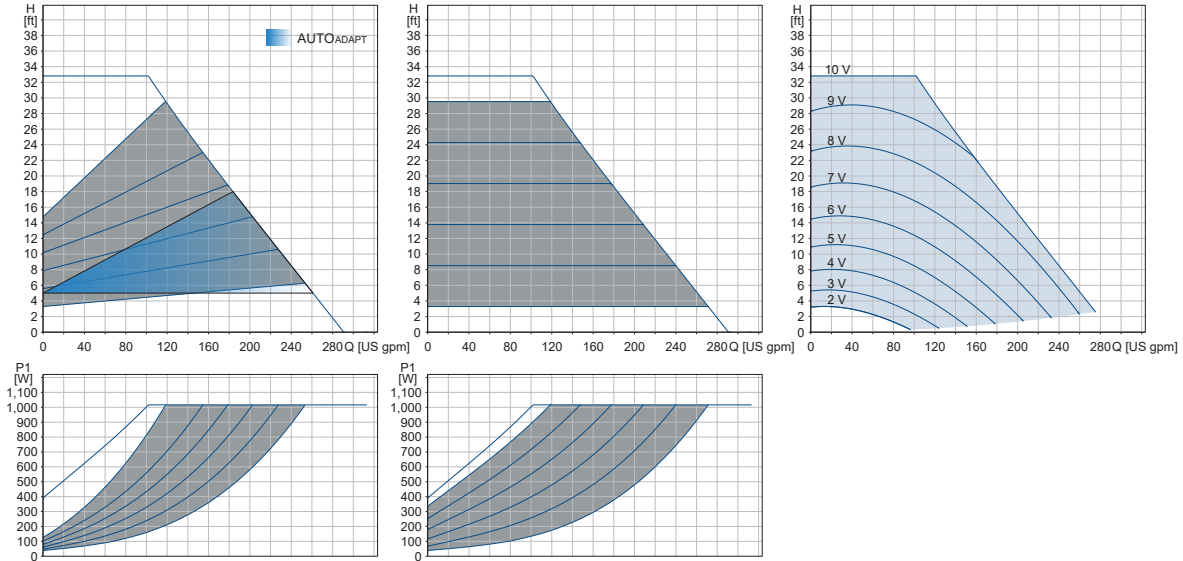

TM081464

Speed	P1 [W] 230 V	I <sub>1</sub> [A] 230 V
Min.	31	0.32
Max.	1017	4.51

The pump incorporates overload protection.

Net weights [lb (kg)]	Ship. vol. [ft <sup>3</sup> (m <sup>3</sup> )]
66.2 (30.0)	2.47 (0.07)

\* External setpoint influence shown with a setpoint of H<sub>max</sub>

- Connections: GF80 flanges.  
See section Pipe connections.
- System pressure: Max. 175 psi (1.2 MPa) (12 bar).
- Liquid temperature: 14 to 230 °F (-10 to +110 °C) (TF 110).
- Specific EEI: 0.17.

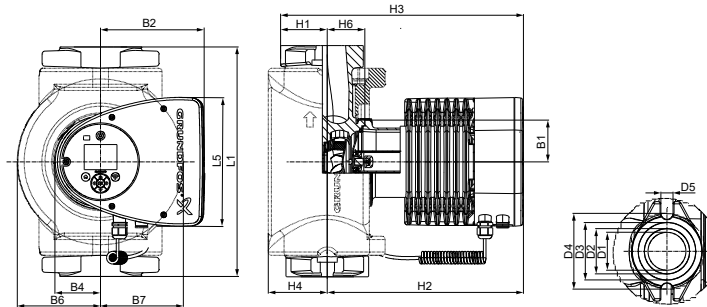

TM1040022

Pump type	Dimensions [in (mm)]								
	L1	L5	B1	B2	B4	B6	B7	D1	D2
MAGNA3 80-100 F (N)	14.17 (360)	8.03 (204)	3.31 (84)	6.46 (164)	2.87 (73)	6.42 (163)	6.42 (163)	3.15 (80)	5.2 (132)
	D3	D4	D5	H1	H2	H3	H4	H6	
	5.91 (150)	7.87 (200)	0.75 (19)	3.7 (94)	12.52 (318)	16.22 (412)	4.53 (115)	2.6 (66)	

For product numbers, see section Product numbers.

### Related information

- [Pipe connections](#)
- [Single-head pumps](#)

# MAGNA3 D 80-100 F

1 x 230 V, 60 Hz

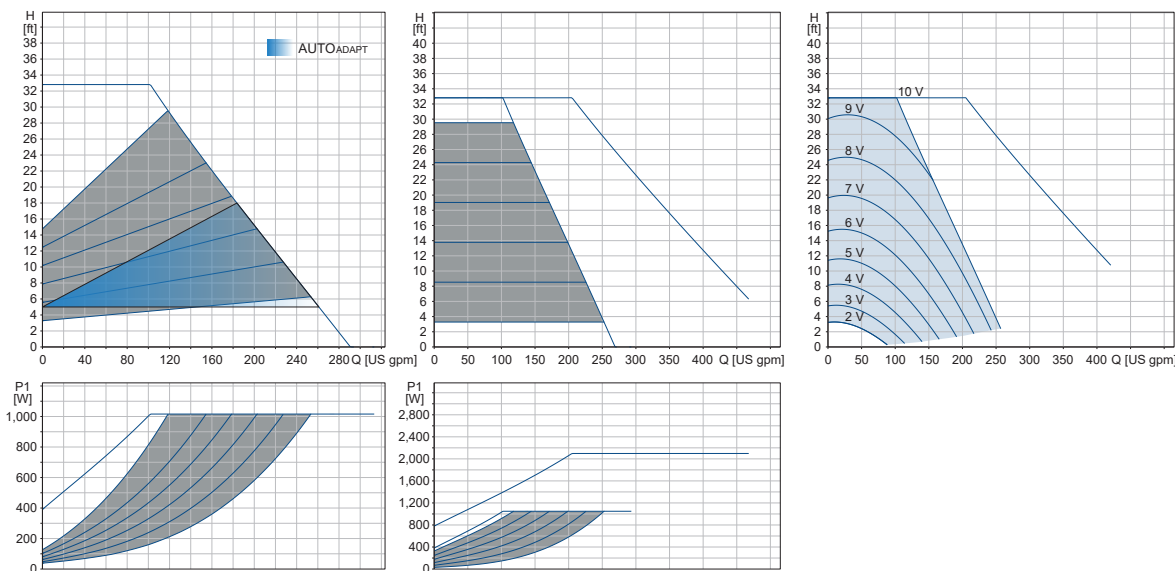

Speed	P1 [W] 230 V	I <sub>1</sub> [A] 230 V
Min.	32	0.32
Max.	1050	4.71

  

Net weights [lb (kg)]	Ship. vol. [ft <sup>3</sup> (m <sup>3</sup> )]
116.9 (53.0)	7.5 (0.208)

The pump incorporates overload protection.

\* External setpoint influence shown with a setpoint of H<sub>max</sub>

- Connections: GF80 flanges. See section Pipe connections.
- System pressure: Max. 175 psi (1.2 MPa) (12 bar).
- Liquid temperature: 14 to 230 °F (-10 to +110 °C) (TF 110).
- Specific EEI: 0.17.

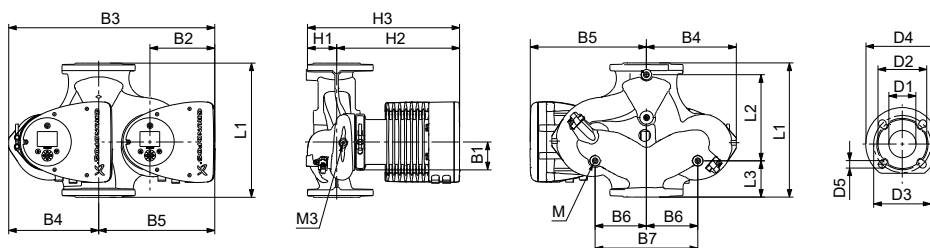

Pump type	Dimensions [in (mm)]								
	L1	L2	L3	L4	L5	B1	B3	B4	B5
MAGNA3 D 80-100 F	14.17 (360)	8.58 (218)	4.02 (102)	4.02 (102)	8.03 (204)	3.31 (84)	21.18 (538)	9.61 (244)	11.57 (294)
	D1	D2	D3	D3 (2)	D4	D5	M	M1	H1
	3.15 (80)	5.04 (128)	5.91 (150)	6.30 (160)	7.87 (200)	0.75 (19)	M12	Rp 1/4	3.82 (97)

For product numbers, see section Product numbers.

## Related information

- [Pipe connections](#)
- [Single-head pumps](#)

TM081465

TM1040020

# MAGNA3 100-120 F (N)

1 x 230 V, 60 Hz

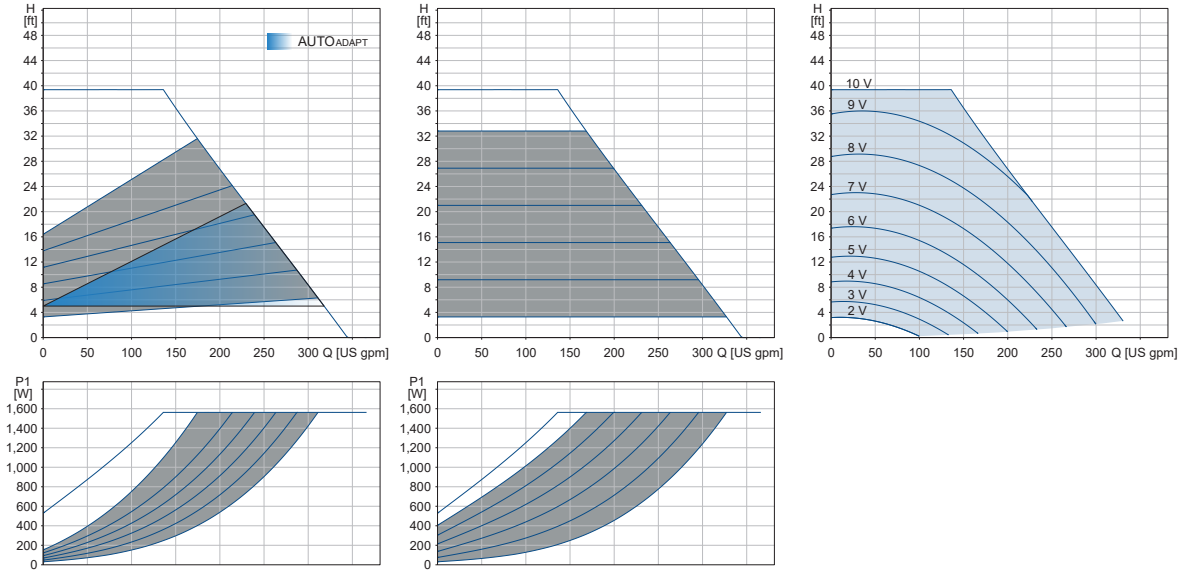

TM081466

Speed	P1 [W] 230 V	I <sub>1</sub> [A] 230 V
Min.	31	0.32
Max.	1564	6.78

The pump incorporates overload protection.

Net weights [lb (kg)]	Ship. vol. [ft <sup>3</sup> (m <sup>3</sup> )]
76.8 (34.8)	3.53 (0.1)

\* External setpoint influence shown with a setpoint of H<sub>max</sub>

Connections:

GF100 flanges.  
See section Pipe connections.

System pressure:

Max. 175 psi (1.2 MPa) (12 bar).

Liquid temperature:

14 to 230 °F (-10 to +110 °C) (TF 110).

Specific EEI:

0.17.

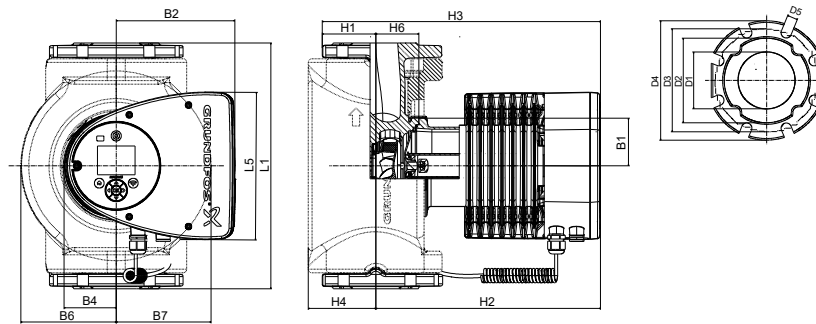

TM1040024

Pump type	Dimensions [in (mm)]								
	L1	L5	B1	B2	B4	B6	B7	D1	D2
MAGNA3 100-120 F (N)	17.72 (450)	8.03 (204)	3.31 (84)	6.46 (164)	2.87 (73)	7.01 (178)	7.01 (178)	3.94 (100)	6.14 (156)
	D3	D4	D5	H1	H2	H3	H4	H6	
	7.52 (191)	8.66 (220)	0.75 (19)	4.02 (102)	12.99 (330)	17.01 (432)	4.72 (120)	3.11 (79)	

For product numbers, see section Product numbers.

## Related information

[Pipe connections](#)

[Single-head pumps](#)

# MAGNA3 D 100-120 F

1 x 230 V, 60 Hz

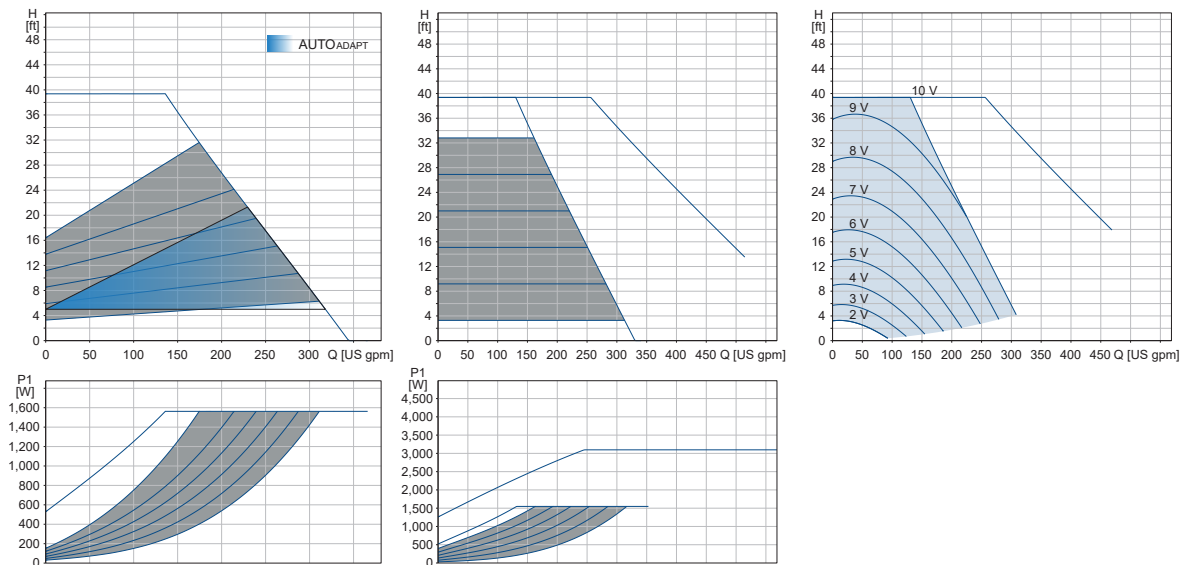

TM081467

Speed	P1 [W] 230 V	I <sub>1</sub> [A] 230 V
Min.	35	0.35
Max.	1550	6.78

The pump incorporates overload protection.

Net weights [lb (kg)]	Ship. vol. [ft <sup>3</sup> (m <sup>3</sup> )]
138.3 (62.7)	7.4 (0.208)

\* External setpoint influence shown with a setpoint of H<sub>max</sub>

Connections:

GF100 flanges.  
See section Pipe connections.

System pressure:

Max. 175 psi (1.2 MPa) (12 bar).

Liquid temperature:

-14 to 230 °F (10 to +110 °C) (TF 110).

Specific EEI:

0.17.

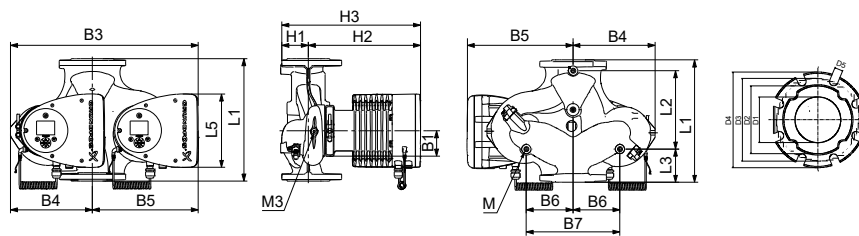

TM1040025

Pump type	Dimensions [in (mm)]								
	L1	L2	L3	L4	L5	B1	B3	B4	B5
MAGNA3 D 100-120 F	17.72 (450)	9.57 (243)	5.79 (147)	5.79 (147)	8.03 (204)	3.31 (84)	21.69 (551)	9.92 (252)	11.77 (299)
	D1	D2	D3	D4	D5	M	M1	H1	H2
	3.94 (100)	6.3 (160)	7.52 (191)	8.66 (220)	0.75 (19)	M12	Rp 1/4	4.06 (103)	12.99 (330)

For product numbers, see section Product numbers.

## Related information

[Pipe connections](#)

[Single-head pumps](#)

## 11. Accessories

### Insulating kits for applications with ice buildup

The accessory is for single-head MAGNA pumps used in applications with ice build-up.

The accessory set consists of two polyurethane (PUR) shells and metal clamps to ensure tight assembly.



TM080511

*Fitting the insulating shells to a MAGNA3 pump*

**Note:** The dimensions of the insulating shells differ from those of the insulating shells for heating systems. You can use the insulating shells for both stainless-steel and cast-iron pumps.

Pump type	Product number
MAGNA3 25-40/60/80/100/120 (N)	98354534
MAGNA3 32-40/60/80/100/120 (N)	98354535
MAGNA3 32-40/60/80/100 F (N)	98354536
MAGNA3 32-120 F (N)	98063287
MAGNA3 40-40/60 F (N)	98354537
MAGNA3 40-80/100 F (N)	98063288
MAGNA3 40-120/150/180 F (N)	98145675
MAGNA3 50-40/60/80 F (N)	98063289
MAGNA3 50-100/120/150/180 F (N)	98145676
MAGNA3 65-40/60/80/100/120 F (N)	96913593
MAGNA3 65-150 F (N)*	99608813
MAGNA3 80-40/60/80/100/120 F*	98134265
MAGNA3 100-40/60/80/100/120 F*	96913589

\* If the control box of the pump is turned, the insulating shells are not applicable. Please contact Grundfos.

Not all variants are available in all markets.

Specifications:

- Specific volume resistance greater than or equal to  $10^{15}$   $\Omega$ cm, DIN 60093
- thermal conductivity at 10 °C 0.036 W/mK and at 40 °C 0.039 W/mK, DIN 52612
- density  $33 \pm 5$  kg/m<sup>3</sup>, ISO 845
- working temperature range -40/+90 °C, ISO 2796.

### CIM modules available for MAGNA3

The following Grundfos Communication Interface Modules (CIM) are compatible with MAGNA3:

Module	Fieldbus protocol	Product number
CIM 050	GENIbus	96824631
CIM 100	LonWorks	96824797
CIM 110	LonWorks for twin pumps	96824798
CIM 150	PROFIBUS DP	96824793
CIM 200	Modbus RTU	96824796
CIM 280-US GIC GEN2 <sup>2)</sup>	Cellular GIC	99895386
CIM 280-US accessories	External 4G/3G antenna for CIM 280-US for North America.	99606613
	Mounting bracket for external 4G/3G antenna	99606614
	Lithium-ion battery pack for CIM 280-US	99499908
CIM 290-MA LPWAN GIC <sup>3)</sup>	Cellular LTE-M GiC	92865300
CIM 290-MA accessories	External 4G antenna for CIM 290-MA for EU and Australia. Mounting bracket included.	93256028
	Antenna for CIM 290-MA for EU. Magnetic foot included.	99838775
CIM 300	BACnet MS/TP	96893770
CIM 500	Ethernet	98301408
CIM 550 Ethernet GIC	GiC	92546689

<sup>2)</sup> CIM 280-US GIC GEN2 is for USA and Canada only.

<sup>3)</sup> CIM 290-MA LPWAN GiC can be used in Australia and in most European countries. Contact Grundfos.



Use booster functional profiles for twin-head pumps.

Installing a communication interface module not listed above might affect the compliance level of the product.

Due to different regulations in different countries, not all the CIM modules in the list can be used worldwide. For detailed information, contact Grundfos.

For further information about data communication via CIM modules, see the CIM documentation available in Grundfos Product Center.

#### Location of the add-on CIM module in MAGNA3

The CIM module is fitted behind the front cover.

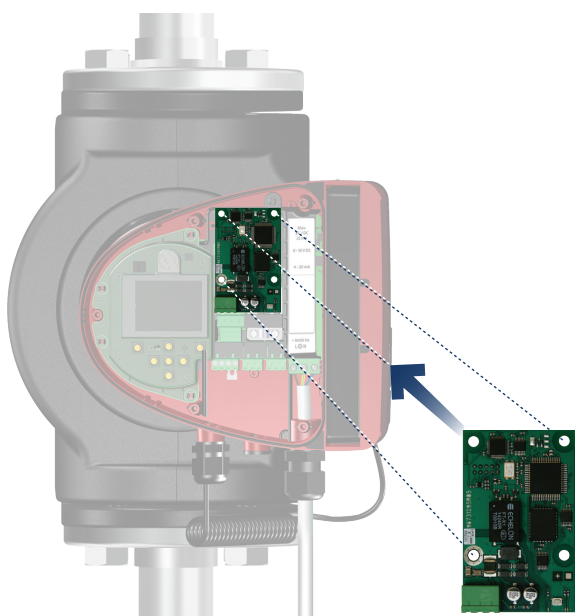

Location of the add-on CIM module in MAGNA3

For installation instructions, please go to:

<http://net.grundfos.com/qr/i/92662506>



TM052914

QR92662506

## Grundfos Remote Management

Application	Description	Product number
CIM 270	Grundfos Remote Management (requires a contract with Grundfos and a SIM card).	96898815
GSM antenna for roof mounting	Antenna for use on top of metal cabinets. Vandal-proof. 2-metre cable. Quad band (global use).	97631956
GSM antenna for desk mounting	Antenna for general-purpose application, for example inside plastic cabinets. To be fixed with the double-adhesive tape supplied. 4-metre cable. Quad band (global use).	97631957

For a GRM contract, contact your local Grundfos company.

## Grundfos GO Remote MI 301

Grundfos GO is used for infrared or radio communication with the pumps.

Various Grundfos GO variants are available. The variants are described in the following.

### MI 301

The Grundfos GO Remote MI 301 module has built-in infrared and radio communication. Use MI 301 in conjunction with an Android or iOS-based smart device with a Bluetooth connection. MI 301 has a rechargeable Li-ion battery and must be charged separately.



TM053890

### MI 301

Supplied with the product:

- Grundfos MI 301
- battery charger
- quick guide.

### Product numbers

Grundfos GO variant	Product number
Grundfos MI 301	98046408

## External Grundfos sensors

### Combined relative-pressure and temperature transmitter

Sensor	Type	Supplier	Measuring range [psi (bar)]	Measuring range [°F (°C)]	Transmitter output [VDC]	Power supply [VDC]	Process connection	Product number
Combined pressure and temperature sensor	RPI T2	Grundfos	0-232 (0-16)	14 to 248 (-10 to +120)	0-10	16.6 - 30	G 1/2	98355521

**Note:** MAGNA3 has only one analog input.

### Pressure sensor

Sensor	Type	Measuring range [psi]	Measuring range [bar]	Transmitter output [mA]	Power supply [VDC]	Process connection	Product number
Pressure transmitter	RPI	0-9	(0 - 0.6)	4 to 20	12 to 30	G 1/2	97748907
		0-15	(0 - 1.0)				97748908
		0-25	(0 - 1.6)				97748909
		0-35	(0 - 2.5)				97748910

### Adapters

Adapter	Product number
Adapter for 1/4" NPT	98344015

## DPI V.2 transmitter

### Combined differential-pressure and temperature transmitter

Scope of delivery:

- DPI V.2 transmitter
- open 6.5 ft (2 m) cable with M12 connection in one end
- capillary tube with fitting
- quick guide.



TM047866

*DPI V.2 transmitter*

Sensor	Measuring range [psi (bar)]	Measuring range [°F (°C)]	Transmitter output	Power supply [VDC]	Temperature measurement	O-ring	Process connection	Product number
						EPDM *		
Grundfos DPI	0 - 8.7 (0 - 0.6)	32-212 (0-100)	4-20 mA	12.5 - 30		•	G 1/2	97747194
			0-10 VDC	16.5 - 30	•	97747202		
Grundfos DPI	0 - 14.5 (0 - 1.0)	32-212 (0-100)	4-20 mA	12.5 - 30		•	G 1/2	97747195
			0-10 VDC	16.5 - 30	•	97747203		
Grundfos DPI	0 - 23.2 (0 - 1.6)	32-212 (0-100)	4-20 mA	12.5 - 30		•	G 1/2	97747196
			0-10 VDC	16.5 - 30	•	97747204		
Grundfos DPI	0 - 36.26 (0 - 2.5)	32-212 (0-100)	4-20 mA	12.5 - 30		•	G 1/2	97747197
			0-10 VDC	16.5 - 30	•	97747205		

**\* Note:**

EPDM: approved for potable water.

FKM: for use in oily media.

## Cable for sensors

Description	Length [ft (m)]	Product number
Screened cable	6.5 (2.0)	98374260
Screened cable	16.4 (5.0)	98374271

## Blanking flange

The accessory is used to blank off the opening when one of the pump heads of a twin-head pump is removed for service to enable uninterrupted operation of the other pump.

The accessory set consists of a blanking flange and a fastener set.

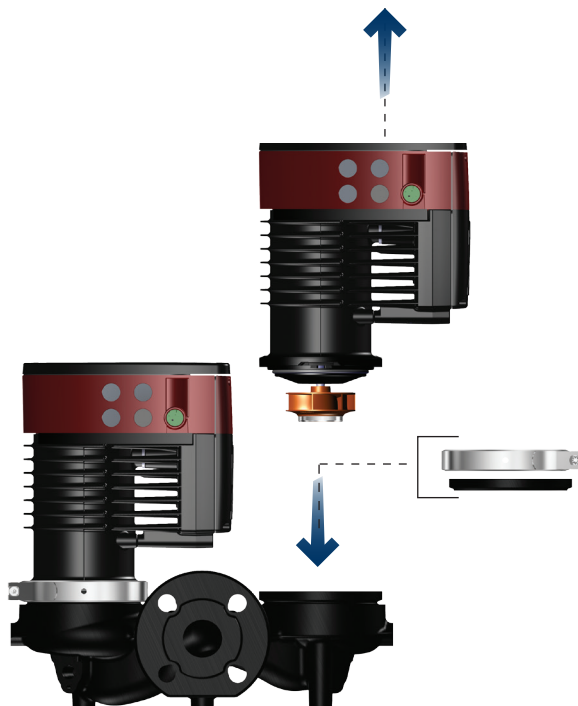

TM068518

*Position of a blind flange*

Pump type	Product number
MAGNA3 D 32-40/60/80/100 (F)	98159373
MAGNA3 D 40-40/60 F	
MAGNA3 D 32-120 F	98159372
MAGNA3 D 40-80/100/120/150/180 F	
MAGNA3 D 50-40/60/80/100/120/150/180 F	
MAGNA3 D 65-40/60/80/100/120/150 F	
MAGNA3 D 80-40/60/80/100/120 F	
MAGNA3 D 100-40/60/80/100/120 F	

Not all variants are available in all markets.

## Pipe connections

The accessory is designed to go from the pump to the pipe, working as an adapter with a specific extension length depending on the adapter type.

The accessory set includes everything you need for installation.

### Flange-flange adapters

Material	Flange	Description	Part number
Cast iron	GF 15/26 flange	3/4" NPT flange fitting set	519601
		1" NPT flange fitting set	519602
		1-1/4" NPT flange fitting set	519603
		1-1/2" NPT flange fitting set	519604
	GF 40/43 flange	1-1/2" NPT flange fitting set	539605
	GF 50 flange	2" NPT flange fitting set	96409354
	GF 53 flange	2" NPT flange fitting set	91584910
		2-1/2" NPT flange fitting set	91584911
		3" NPT flange fitting set	91584912
		GF 65 flange	2-1/2" NPT flange fitting set
GF 80 flange	3" NPT flange fitting set	569601	
GF 100 flange	4" NPT flange fitting set	579801	
Stainless steel	GF 65 flange	Stainless steel, 2-1/2" NPT flange fitting set	91121951
<b>Replacement flange gaskets</b>			
GF 15/40		2-bolt, single o-ring for 1-1/2" flange	98476425

## 12. Product numbers

### Single-head pumps

Single-head pump type	Port-to-port length [in. (mm)]	Flange connection	Cast iron		Stainless steel (N)		Section
			115 V	208-230 V	115 V	208-230 V	
MAGNA3 32-60 F (N)	6 - 1/2 (165)	GF	98126820		98126822		MAGNA3 32-60 F (N)
MAGNA3 32-100 F (N)	6 - 1/2 (165)	GF	98126824		98126826		MAGNA3 32-100 F (N)
MAGNA3 32-120 F (N)	6 - 1/2 (165)	GF	99833304		99833308		MAGNA3 32-120 F (N)
MAGNA3 40-80 F (N)	8 - 9/16 (216)	GF	98126800	98126828	98126802	98126830	MAGNA3 40-80 F (N)
MAGNA3 40-120 F (N)	8 - 9/16 (216)	GF	98126804	98126832	98126806	98126834	MAGNA3 40-120 F (N)
MAGNA3 40-180 F (N)	8 - 9/16 (216)	GF	98126808	98126836	98126810	98126838	MAGNA3 40-180 F (N)
MAGNA3 50-80 F (N)	9 - 1/2 (240)	DN50	98126812	98126840	98126814	98126842	MAGNA3 50-80 F (N)
MAGNA3 50-120 F (N)	11 - 1/16 (280)	DN50	99833473	99833476	99833475	99833477	MAGNA3 50-120 F (N)
MAGNA3 50-150 F (N)	11 - 1/16 (280)	DN50	98126816	98126844	98126818	98126846	MAGNA3 50-150 F (N)
MAGNA3 50-180 F (N)	11 - 1/16 (280)	DN50	99833480	99833483	99833481	99833485	MAGNA3 50-180 F (N)
MAGNA3 65-120 F (N)	13 - 7/16 (340)	DN65	98124696	98126848	98124702	98126850	MAGNA3 65-120 F (N)
MAGNA3 65-150 F (N)	13 - 7/16 (340)	DN65	-	98126852	-	98126854	MAGNA3 65-150 F (N)
MAGNA3 80-100 F (N)	14 - 3/16 (360)	DN80	-	98126856	-	98126858	MAGNA3 80-100 F (N)
MAGNA3 100-120 F (N)	17 - 3/4 (450)	DN100	-	98126860	-	98126862	MAGNA3 100-120 F (N)

## Twin-head pumps

Twin-head pump type	Port-to-port length [in. (mm)]	Flange connection	Cast iron		Stainless steel (N)		Section
			115 V	208-230 V	115 V	208-230 V	
MAGNA3 D 65-150 F	13 - 7/16 (340)	DN65	-	98126863	-	-	<a href="#">MAGNA3 D 65-150 F</a>
MAGNA3 D 80-100 F	14 - 3/16 (360)	DN80	-	98126864	-	-	<a href="#">MAGNA3 D 80-100 F</a>
MAGNA3 D 100-120 F	17 - 3/4 (450)	DN100	-	98126865	-	-	<a href="#">MAGNA3 D 100-120 F</a>

**Note:** Click on the product number and go directly to the performance curve in Grundfos Product Center.

## 13. Grundfos Product Center

Online search and sizing tool to help you make the right choice.

From the international view, you can select your specific country to view the product range available to you.

International view: <http://product-selection.grundfos.com>

### All the information you need in one place

Performance curves, technical specifications, pictures, dimensional drawings, motor curves, wiring diagrams, spare parts, service kits, 3D drawings, documents, system parts. The Product Center displays any recent and saved items - including complete projects - right on the main page.

### Downloads

On the product pages, you can download installation and operating instructions, data booklets, service instructions, etc., in PDF format.

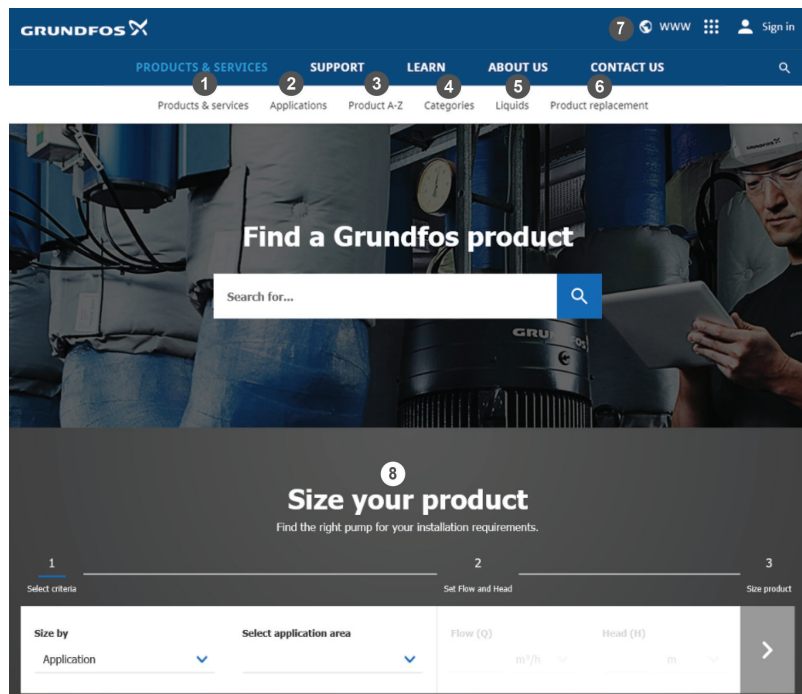
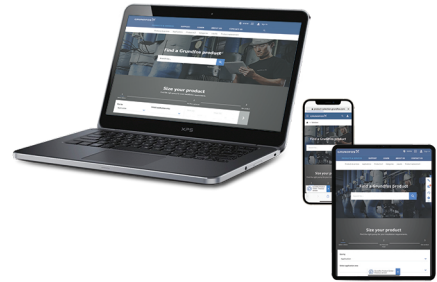

When you select your country, you will see the menus below. Note that some menus may not be available depending on the country.

Example: <https://product-selection.grundfos.com/uk>

Pos.	Description
1	<b>Products &amp; services</b> enables you to find products and documents by typing a product number or name into the search field.
2	<b>Applications</b> enables you to choose an application to see how Grundfos can help you design and optimize your system.
3	<b>Products A-Z</b> enables you to look through a list of all the Grundfos products.
4	<b>Categories</b> enables you to look for a product category.
5	<b>Liquids</b> enables you to find pumps designed for aggressive, flammable or other special liquids.
6	<b>Product replacement</b> enables you to find a suitable replacement.
7	<b>WWW</b> enables you to select the country, which changes the language, the available product range and the structure of the website.
8	<b>Sizing</b> enables you to size a product based on your application and operating conditions.

<b>92662550</b> 12.2025
ECM: 1438617

**GRUNDFOS Holding A/S**  
Poul Due Jensens Vej 7  
DK-8850 Bjerringbro  
Tel: +45 87 50 14 00  
[www.grundfos.com](http://www.grundfos.com)

