



# AQUAVAR<sup>®</sup> CPC

(Centrifugal Pump Control)

**INSTALLATION AND OPERATION MANUAL**

# AQUAVAR® CPC

## Centrifugal Pump Controller

### Quick Start Guide



#### Overview

The installation of the AQUAVAR CPC adjustable speed drive follows the outline below.

- | Task                      |
|---------------------------|
| PREPARE for installation  |
| UNPACK the drive          |
| PREPARE mounting location |
| REMOVE the front cover    |
| MOUNT the drive           |
| INSTALL wiring            |
| CHECK installation        |
| REINSTALL the cover       |
| APPLY power               |
| START-UP Wizards          |

#### Application

This guide provides a quick reference for installing Aquavar CPC drives having a standard enclosure (NEMA 1).

**NOTE:** This guide does not provide detailed installation, safety or operational instructions. See the installation Operation Manual for complete information.

#### Prepare for Installation

**WARNING!** The Aquavar should ONLY be installed by a qualified electrician.

##### Check

- Motor Compatibility - Motor type, nominal current, frequency and voltage range must match drive specifications (3 phase motor only).
- Suitable Environment - Drive requires heated, indoor controlled environment that is suitable for the selected enclosure below 104° F.
- Wiring - Follow local codes for wiring and fusing requirements. Refer to NEC, Local, State or Municipal codes.

Refer to the Installation Operation Manual and confirm that all preparations are complete.

##### Tools Required

Screwdrivers, wire stripper, tape measure, mounting screws or bolts, and drill.  
Use the following chart to interpret the type code found on the drive label.

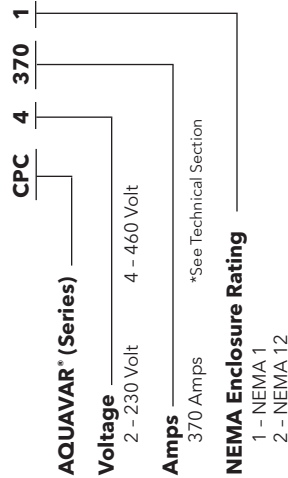

##### Options

\* Consult factory for other options, if available. Not all combinations may be available.

##### Collect Motor Data

Collect the following data from the motor nameplate for later use in the Aquavar startup:

- Voltage \_\_\_\_\_
- Nominal Motor Current \_\_\_\_\_
- Nominal Frequency \_\_\_\_\_
- Nominal Speed \_\_\_\_\_
- Nominal Power \_\_\_\_\_

#### Unpack the Drive

**NOTE:** Lift the Aquavar by its chassis and not by its cover.

1. Unpack the drive.
2. Check for any damage and notify the shipper immediately if damaged components are found.

3. Check the contents against the order and the shipping label to verify that all parts have been received.

#### Prepare the Mounting Location

The drive requires a smooth, vertical, solid surface, free from heat and moisture, with free space for air flow - 200 mm (8 in.) above and below, and 25 mm (1 in.) around the sides of the drive.

1. Mark the mounting points.
2. Drill the mounting holes.

#### Remove the Front Cover

1. Remove the control panel (display), if attached.
2. Loosen the captive screw at the top.
3. Pull near the top to remove the cover.

#### Mount the Drive

1. Position the AQUAVAR and use screws or bolts to securely tighten all four corners.
2. Attach a warning appropriate language on the inside plastic shell.

#### Install the Wiring (copper only)

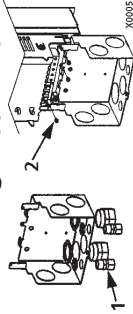

1. Install thin-wall conduit clamps (not supplied) in the conduit/gland box.
2. Install conduit/gland box.

##### Wiring Power

1. Connect conduit runs to box.
2. Route input power and motor wiring through conduits.

3. Strip wires.
4. Connect power, motor and ground wires to the drive terminals. See "Power Connections" in the instruction manual.

#### Frame Sizes R1...R4

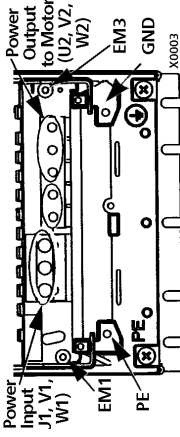

\* Single phase input power must use U1, W1 and PE for wiring.

**WARNING!** For floating networks remove screws at EM1 and EM3 on Frame Sizes R1...R4.

#### Frame Size R5

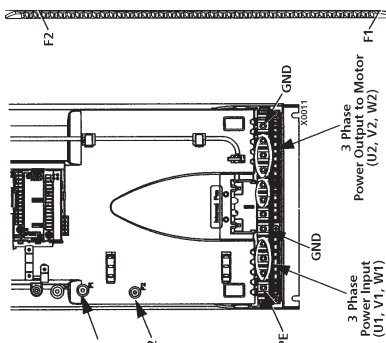

#### Frame Size R6

**WARNING!** For floating networks remove screws at F1 and F2 on Frame Sizes R5 or R6.

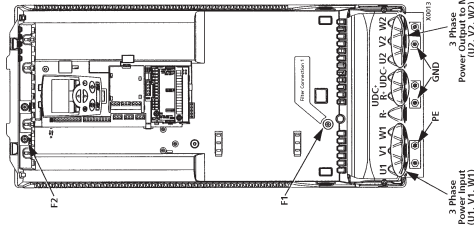

## Wiring the Transducer

- Route the transducer cable through the conduit.
- Strip the transducer cable sheathing and twist the screen wire.
- Connect the screen wire of the transducer to terminal X1-1.
- Connect the power supply wire of the transducer (red or brown) to terminal X1-10.
- Connect analog output wire from the transducer (white or black) to X1-5. See chart in next column.

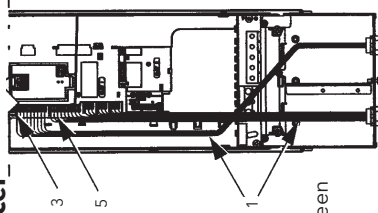

### Note 1. Jumper Setting: (Analog Input)

- J1**
- AI1: 0...10 V
  - AI2: 0(4)...20 mA (default)

Relay Outputs	Relay output 1, programmable. Default <sup>2</sup> = run power to drive	Relay output 2, programmable. Default <sup>2</sup> = ready, pump is running	Relay output 3, programmable. Default <sup>2</sup> = not used
19 RO1C	Maximum: 250 VAC/30 VDC, 2 A	Maximum: 250 VAC/30 VDC, 2 A	Maximum: 250 VAC/30 VDC, 2 A
20 RO1A	Minimum: 500 mW (12 V, 10 mA)	Minimum: 500 mW (12 V, 10 mA)	Minimum: 500 mW (12 V, 10 mA)
21 RO1B			
22 RO2C			
23 RO2A			
24 RO2B			
25 RO3C			
26 RO3A			
27 RO3B			

- Install the conduit/gland box cover (1 screw).

X1	Control Wiring	Analog I/O	Digital Inputs <sup>1</sup>
1	Terminal for transducer shield. (Connected internally to chassis ground.)	(-) Transducer (4-20 mA)	12 DCOM
2	AI1	Transducer Power Supply (Brown or Red)	13 D11
3	AGND	Connection (White or Black)	14 D12
4	+10V		15 D13
5	AI2		16 D14
6	AGND		17 D15
7	AO1		18 D16
8	AO2		
9	AGND		
10	+24V		
11	GND		

X1	Control Wiring	Digital Inputs <sup>1</sup>
10-15	Estop or Jumper	13 D11
16	Estop/start Jumper to +24V for enable (15 to 10 Jumper)	14 D12
17		15 D13
18		16 D14
19		17 D15
20		18 D16

## Reinstall the Cover

- Align the cover and slide it on.
- Tighten the captive screw.
- Reinstall the control panel.

## Apply Power

Always reinstall the front cover before turning power on.



**WARNING!** The AQUAVAR will start up automatically at power up, if the external run command is on.

- Apply input power.

When power is applied to the AQ-UAVAR, the green LED comes on.

**NOTE!** Before increasing motor speed, check that the motor is running in the desired direction.

## Start-Up

In Start-Up, enter motor data (collected earlier) and, if needed, edit parameters that define how the drive operates and communicates.

### Wizards

The Start-Up Wizard steps through typical start-up selections and runs automatically upon the initial power up. At other times, use the steps below to run the Start-Up Wizard.

- Use the MENU key to access the Menu list.
- Select Wizards.
- Select Start-Up Wizards.
- Follow the screen instructions to configure the system.

**DEFAULT PASSWORD IS "66".**

**NOTE!** For common parameters and menu items, use the Help Key (H) to display descriptions. If you encounter Alarms or Faults, use the Help Key or refer to the Diagnostic section of the instruction manual.

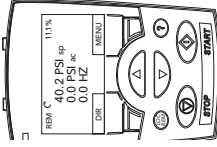

## Check Installation

Before applying power, perform the following checks.

Check	Check
Environment conforms to specifications.	Environment conforms to specifications.
The drive is mounted securely.	The drive is mounted securely.
Proper cooling space around the drive.	Proper cooling space around the drive.
Motor and driven equipment are ready for start.	Motor and driven equipment are ready for start.
Floating networks: Internal RFI filter disconnected.	Floating networks: Internal RFI filter disconnected.
Drive is properly grounded, with pump/motor.	Drive is properly grounded, with pump/motor.
Input power (mains) voltage matches the drive nominal input voltage.	Input power (mains) voltage matches the drive nominal input voltage.
The input power (mains) terminals, U1, V1, W1, are connected and tightened as specified.	The input power (mains) terminals, U1, V1, W1, are connected and tightened as specified.
The input power (mains) fuses / mains switch is installed.	The input power (mains) fuses / mains switch is installed.
The motor terminals, U2, V2, W2, are connected and tightened as specified.	The motor terminals, U2, V2, W2, are connected and tightened as specified.
Motor cable is routed away from other cables.	Motor cable is routed away from other cables.
NO power factor compensation capacitors are connected to the motor cable.	NO power factor compensation capacitors are connected to the motor cable.
Control terminals are wired and tightened as specified.	Control terminals are wired and tightened as specified.
NO tools or foreign objects (such as drill shavings) are inside the drive.	NO tools or foreign objects (such as drill shavings) are inside the drive.
NO alternate power source for the motor is connected - no input voltage is applied to the output of the drive.	NO alternate power source for the motor is connected - no input voltage is applied to the output of the drive.

## FEATURES

### Quick Reference Guide

Analog Output, 102

Auto Restart, 102

Energy Savings Information, 103

Fieldbus Control, 103

Keypad (Control Panel), 104

Language, 104

Locking, 104

Low Water Protection, 108

Manual Override, 104

Minimum Speed Options, 105

Priming Delay, 106

Pump Protect Control, 107

Ramp Hysteresis, 113

Ramp Settings, 113

Regulation Mode, 107

Relay Outputs, 107

Restart Value, 106

Secondary Protection, 108

Setpoints, Dual, 109

System Curve Compensation, 110

Test Run, 111

Tuning, 111

Window (Regulation), 112

# TABLE OF CONTENTS

## Section 1 SAFETY

Use of Warnings and Notes.....	7
--------------------------------	---

## Section 2 POWER DISTRIBUTION SYSTEMS

Delta / Wye with grounded Wye neutral .....	9
Delta / Delta with grounded leg.....	9
Ungrounded secondary.....	9
Resistance grounding and ground fault protection.....	10
Open Delta.....	10
Single Phase Connection.....	10

## Section 3 INTRODUCTION

Input Power and Line Transformer Requirements .....	11
Issues for Drive Input Isolation Transformers .....	11
Installation Flow Chart .....	13
Aquavar CPC Product Numbering .....	14
Preparing for Installation; Drive Identification .....	15

## Section 4 INSTALLATION (Frames R1-R6)

Supply Connection.....	19
Thermal Overload and Short-Circuit Protection .....	19
Ground Fault Protection.....	19
Emergency Off Devices .....	19
Selecting the Power Cables.....	20
Motor Cable Shield .....	20
Additional US Requirements.....	20
Installing the Drive.....	21
Wiring Connection Diagrams .....	24
Single Phase Wiring / Connection Diagram .....	26
Wiring IP 21 / UL Type 1 Enclosure with Conduit.....	27
Wiring IP 54 / UL Type 12 Enclosure with Conduit.....	28
Power Connections .....	29
Control Wiring.....	30
Communications.....	31
Installation Check Sheet .....	32
Reinstall Cover .....	33

## Section 4 INSTALLATION (Frames R7-R8)

Aquavar Drive Manuals Descriptions.....	34
Introduction, Planning , Moving the Unit and Mounting .....	35
Connecting Power and Control Cables .....	36
R7 Frame Size.....	37
R8 Frame Size.....	38
Maintenance.....	39
Technical Data - Extension Module R7.....	41
Detail R7 .....	42
Technical Data - Extension Module R8.....	43
Detail R8 .....	44

## Section 5 START-UP

Wizards and Assistant Control Panel (Display).....	45
Controls / Display Overview.....	45
Start-Up Wizard.....	48

## Section 6 PARAMETER LISTINGS

Aquavar CPC Parameter List .....	50
----------------------------------	----

## Section 7 PROGRAMMING

Single Pump Programming (Pressure Transducer) .....	73
Single Pump - Submersible Pump Constant Pressure .....	78
MultiPump - Constant Pressure Control .....	87
MultiPump - Slave Pump Control .....	94

## Section 8 FEATURES

Analog Outputs .....	102
Auto Restart, Energy Saving Information (Group 26).....	102

## TABLE OF CONTENTS

Fieldbus Control .....	103
Language, Locking .....	104
Minimum Speed Options .....	105
Priming Delay, Pump Protect Ctrl, Regulation Mode .....	106-107
Relay Outputs; Restart Options; Low Water (Suction) Protection .....	107-108
Keypad Failure .....	109
Set Points, Dual with example .....	109
System Curve Compensation .....	110
Test Run; Tuning, System Pressure .....	111
Window Setting (Reg Window) .....	112
Ramp Hysteresis .....	113
Adjusting Ramp Rates .....	113
<b>Section 9 FAULTS/ALARMS</b>	
Diagnostic Displays .....	115
Correcting Faults .....	116
Fault Resetting .....	119
Correcting Alarms .....	120
<b>Section 10 MAINTENANCE (Frame Sizes R1-R6)</b>	
Maintenance Intervals .....	122
Heatsink .....	122
Main Fan Replacement .....	122
Internal Enclosure Fan Replacement .....	123
Capacitors .....	124
Control Panel .....	124
<b>Section 10 MAINTENANCE (Frame Sizes R7-R8)</b>	
Layout .....	125
Heatsink, Fan .....	126
Replacing the Fan .....	126
Capacitors .....	128
LEDs .....	129
Control Panel .....	129
<b>Section 11 TECHNICAL DATA</b>	
Sizing; Derating .....	130
Cable Sizing / Ratings 208-240 Volt Drives .....	131
Cable Sizing / Ratings 380-480 Volt Drives .....	132
Fuse Sizing / Ratings 208-240 Volt Drives .....	133
Fuse Sizing / Ratings 380-480 Volt Drives .....	134
Cable Terminals (frames R1-R6 and frames R7-R8) .....	135
Input Power (Mains) Connection .....	136
Motor Connection .....	136
Control Connection .....	137
Efficiency (frames R1-R8); Cooling (frames R1-R6) .....	137
Cooling (frames R7-R8); Mounting Orientations a & b .....	138
Air Flow 380-480 Volt Drives .....	139
Air Flow 208-240 Volt Drives .....	140
Dimensions and Weights (Frames R1-R6) .....	141
Units with IP 54 / UL Type 12 Enclosures .....	143
Weights and Dimensions (Frames R7-R8) 460 Volt .....	144
Degrees of Protection .....	144
Ambient Conditions .....	145
Materials; Applicable Standards .....	146
UL Markings; Liability Limits .....	147
<b>Section 12 APPENDIX</b>	
Pressure Transducer .....	148
Transducer Data / Specifications Drawing #A00462C .....	149
Transducer Data / Specifications Drawing #A00436C .....	150
Spare Parts List .....	151
Warranty .....	152



## SAFETY



**WARNING!** The AQUAVAR adjustable speed AC drive should ONLY be installed by a qualified electrician.



**WARNING!** Even when the motor is stopped, dangerous voltage is present at the Power Circuit terminals U1, V1, W1 and U2, V2, W2 and, depending on the frame size, UDC+ and UDC-, or BRK+ and BRK-.



**WARNING!** Dangerous voltage is present when input power is connected. After disconnecting the supply, wait at least 5 minutes (to let the intermediate circuit capacitors discharge) before removing the cover.



**WARNING!** Even when power is removed from the input terminals of the AQUAVAR, there may be dangerous voltage (from external sources) on the terminals of the relay outputs R01...R03.



**WARNING!** When the control terminals of two or more drive units are connected in parallel, the auxiliary voltage for these control connections must be taken from a single source which can either be one of the units or an external supply.



**WARNING!** The AQUAVAR CPC wall mount version is not a field repairable unit. Never attempt to repair a malfunctioning unit; contact the factory or your local Authorized Service Center for replacement.



**WARNING!** The AQUAVAR will start up automatically after an input voltage interruption if the external run command is on.



**WARNING!** The heat sink may reach a high temperature, in excess of 200° F. Severe burns are possible.



**WARNING!** If the drive will be used in a floating network, remove screws at EM1 and EM3 (Frame size R1...R4), or F1 and F2 (Frame size R5 or R6). See diagrams on pages 24 and 25 respectively.

**NOTE!** For more technical information, contact the factory or your local AQUAVAR representative.



**WARNING!** Always consult your local, state, municipal or NEC codes for proper wiring, electrical installation of inverter drives and AC motors.

## USE OF WARNINGS AND NOTES

There are two types of safety instructions throughout this manual:

- Notes draw attention to a particular condition or fact, or give information on a subject.
- Warnings caution you about conditions which can result in serious injury or death and/or damage to the equipment. They also tell you how to avoid the danger. The warning symbols are used as follows:



**DANGEROUS VOLTAGE WARNING** warns of high voltage which can cause physical injury and/or damage to the equipment.



**GENERAL WARNING** warns about conditions, other than those caused by electricity, which can result in physical injury and/or damage to the equipment.

**TYPICAL DRIVE LABEL**

SW: **ACS550-U1-046A-2**

**ACS550-U1-046A-2**

SW:

V.2.06B

V.2.06B

2053901277



**S/N2053901277**



**S/N2053901277**

2053901277

<b>Input</b>	<b>3 PH 48...63</b>	<b>1 PH 48...63 Hz</b>
<b>Voltage (U1)</b>	<b>208...240 Vac</b>	<b>208...240 Vac</b>
<b>Current (11n)</b>	<b>46.2 A</b>	<b>46.2 A</b>
<b>Short Circuit</b>	<b>100 kAIC</b>	<b>100 kAIC</b>
<b>Output</b>	<b>3 PH 0...500 Hz</b>	<b>3 PH 0...500 Hz</b>
<b>Voltage (U2)</b>	<b>0...U1 Vac</b>	<b>0...U1 Vac</b>
<b>Current (12n)</b>	<b>46.2 A</b>	<b>22 A</b>
<b>Current (12hd)</b>	<b>30.8 A</b>	
<b>Power (Pn)</b>	<b>15 HP</b>	<b>7.5 HP</b>
<b>Power (Phd)</b>		

Made in USA of foreign parts



Mfg. Date: 31-October-2005

Orig. Firmware: V.2.06B



**S/N2053901277**



**ACS550-U1-046A-2**



# POWER DISTRIBUTION SYSTEMS

The type of transformer and the connection configuration feeding a drive plays an important role in its performance and safety. The following is a brief description of some of the more common configurations and a discussion of their virtues and shortcomings. Always ask what type of power system the site has before sizing the drive.

## Delta / Wye with grounded Wye neutral:

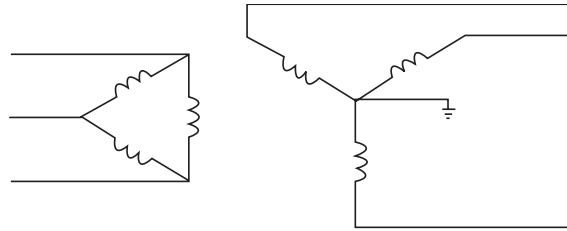

This configuration is one of if not the most common. It provides rebalancing of unbalanced voltage with a 30 degree phase shift. Depending on the output connections from the drive to motor, the grounded neutral may be a path for common mode current caused by the drive output.

## Delta / Delta with grounded leg:

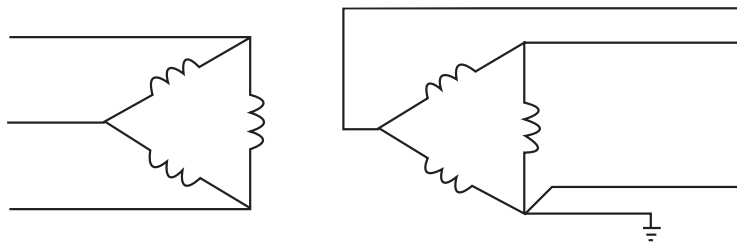

Another common configuration providing voltage rebalancing with no phase shift between input and output. Again, depending on the output connections from the drive to motor, the grounded neutral may be a path for common mode current caused by the drive output.

## Ungrounded secondary:

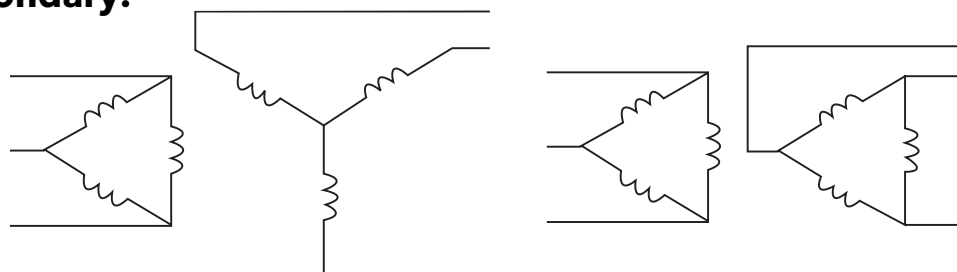

Grounding of the transformer secondary is essential to the safety of personnel as well as the safe operation of the drive. Leaving the secondary floating can permit dangerously high voltages between the chassis of the drive and the internal power structure components. In many cases this voltage could exceed the rating of the input MOV protection devices of the drive causing a catastrophic failure. In all cases, the input power to the drive should be referenced to ground. If the transformer can not be grounded, then an isolation transformer must be installed with the secondary of the transformer grounded.

# POWER DISTRIBUTION SYSTEMS

## Resistance grounding and ground fault protection:

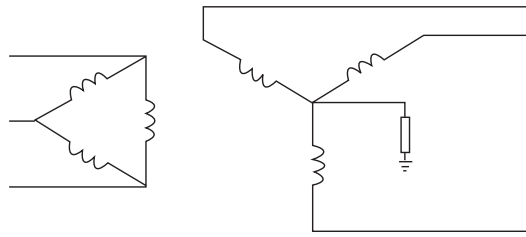

Connecting the Wye secondary neutral to ground through a resistor is an acceptable method of grounding. Under a short circuit secondary condition, any of the output phases to ground will not exceed the normal line to line voltage. This is within the rating of the MOV input protection devices on the drive. The resistor is often used to detect ground current by monitoring the associated voltage drop. Since high frequency ground current can flow through this resistor, care should be taken to properly connect the drive motor leads using the recommended cables and methods. In some cases, multiple drives on one transformer can produce a cumulative ground current that can trigger the ground fault interrupt circuit.

## Open Delta (consult factory):

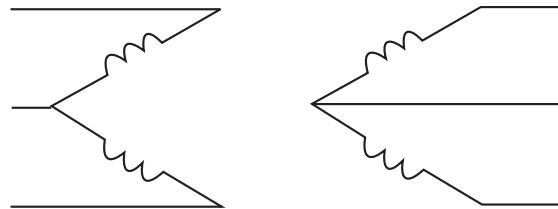

This type of configuration is common on 230 volt systems. From time to time it may be encountered where only single phase power is available and three-phase power is required. The technique uses two single phase transformers to derive a third phase. When used to power a drive this configuration must be derated to about 70% of the single phase rating of one transformer. This system provides poor regulation and it is possible that only the two line connected phases will provide power. In this case the drive must be derated to 50% of its rating. (Ex. A 20 HP 230 volt drive now becomes a 10 HP 230 volt drive.)

## Single Phase Connection:

For small drive with a diode rectifier front end it is possible to run a three phase output with a single phase input. Only part of the three phase input bridge is used. Ripple current becomes 120 Hz rather than 360. This places a greater demand on the DC filter components (capacitor bank and DC choke). The result is that the drive must be derated to 50% current. Single phase will not work with an SCR front end drive.

# INTRODUCTION

## Input Power and Line Transformer Requirements

The Aquavar CPC™ requires that the input line voltage and transformer power that meet certain phase and balance requirements. **If you or your installing electrical contractor is in doubt of the requirements, the following provide guidelines for the Aquavar CPC. When in doubt contact the local power utility or the factory.**

Drive input isolation transformers are not generally required for the Aquavar CPC. The Aquavar CPC utilizes as standard 3% line impedance, therefore unless additional filtering is needed, an input line reactor is not required.

**NOTE: 60 THROUGH 550 HP UNITS PROVIDE AN ACTUAL 3% IMPEDANCE LINE REACTOR BUILT INTO THE DRIVE CABINET.**

The internal power circuit of the drive is floating with respect to earth ground except for transient protection (MOV's and EMI capacitors) therefore earth ground potential reference is established only by the user's power line grounding configuration. The drive can operate with many different power grounding schemes. The drive requires only that the steady state RMS voltage from any input line to ground be always less than 110% of the nominal power line to line voltage. The use of optional RFI/EMC filters may require that the voltage from any input line to ground be less than 110% of the nominal power line to neutral voltage.

### Drive input isolation or dry type transformers may be required for the following:

- 1. Step up or down:** An input transformer may be required to step the local input power line voltage up or down to the level of the drive input rating.
- 2. Ground Isolation:** An input isolation transformer with a direct or a high impedance wye neutral secondary ground connection may be required to establish a local power source with a ground relationship different from the utility power source.
  - A. If ground isolation is required to prevent a ground fault in one section from shutting down equipment in another section.
  - B. To bring local line voltages within the line to ground limits (110% balance) stated in the opening paragraph.
  - C. Some ground fault protection schemes and peripheral components require a grounded neutral power source.
  - D. A symmetrical wye neutral grounded power source along with proper ground wiring techniques according to NEC (good ac grounding from motor to drive and from drive to earth ground) provides the best means to control the ground currents that the drive switching frequency and dv/dt rate insert into the motor frame and shaft.
- 3. Phase shifting** delta-wye or "zig-zag" isolation transformers are used to feed 12 or 18 pulse drive inputs to provide harmonic mitigation.

If an isolation transformer is used for 6 pulse input, **the best choice is ONE three phase, six winding transformer. A delta primary is best for third harmonic cancellation.** A wye secondary avoids circulating current problems and provides the very desirable option of grounding the secondary neutral for minimum voltage stress and ripple to ground. The transformer should have a KVA rating at least 1.1 times the maximum connected HP. A K Factor of 6 is sufficient if transformer impedance is greater than 2%. A K Factor of 5 is sufficient

# INTRODUCTION

if transformer impedance is greater than 3%. The transformer manufacturer may provide derating for non K Factor rated transformers to operate at the drive produced K Factor levels.

Other transformer configurations are acceptable. **Three single phase transformers can be used if they are identical for phase to phase symmetry and balance.** A wye connected primary neutral should never be grounded. Great care should be taken with delta primary delta secondary configurations. Any lack of phase to phase symmetry could result in circulating currents and unacceptable transformer heating.



**WARNING!** Never use phase converters with drives as nuisance tripping and possible damage may occur. Size the drive for single phase input using 50% derate factor.



**WARNING!** Use of "Open Delta" 230 volt power systems should be sized using the 50% derate factor. Consult factory.

**Sometimes drive input isolation transformers are specified to deal with one or more of the following issues:**

- 1. Short Circuit Protection:** Input transformers are sometimes used to provide impedance to reduce the available short circuit current to levels that the input clearing devices, such as fuses or circuit breakers, are rated to handle. **Line reactors can perform this impedance function much more cost effectively.**
- 2. Transient Protection:** Input transformers are sometimes used to provide transient surge impedance. All the Aquavar CPC drives have capacitors and MOV's (Metal Oxide Varistor transient protectors) providing 120 to 360 joules, line to line and line to ground transient protection. Isolation transformers are not required for this protection within those energy levels. Additional distribution transformer primary transient surge arrestors may be required if the potential transient energy reflected to the drive exceed those levels. MOV's are rated to handle high levels of one shot transient energy. MOV's are not meant to handle continuously recurring transients. A problem of continuously recurring transients should be corrected before connecting a drive.
- 3. Harmonic Mitigation:** Input transformers are sometimes used to provide impedance to reduce the harmonic currents generated in the drive. **Line reactors can perform this function much more cost effectively.**
- 4. Power Factor Capacitor Isolation:** Input transformers are sometimes used to provide impedance to isolate drives from line connected power factor correction capacitors. PWM drive inputs do not require power factor correction capacitors as drive power factors are generally greater than 92% and cannot be significantly improved with power factor correction capacitors which only correct for fundamental. However drives should be isolated from power factor correction capacitors by about 3 to 6% additional impedance with respect to the drives. Line reactors can perform this function much more cost effectively than isolation transformers. ABB drives have either an internal 3% line reactor or an equivalent 3 to 5% bus reactor.
- 5. RFI/EMI Mitigation:** Neither input isolation transformers nor line or bus reactors provide good high frequency filtering although an isolation transformer with a static shield will provide some RFI mitigation. If RFI/EMI mitigation is required, an RFI/EMI filter mounted inside the drive should be used together with all the proper wiring and grounding techniques. Some RFI/EMI filters may operate only on a power source with a grounded neutral. Establishing a local neutral ground may require the use of an input isolation transformer.

# INTRODUCTION

Study these installation instructions carefully before proceeding. **Failure to observe the warnings and instructions may cause a malfunction or personal hazard.**



**WARNING!** Before you begin read "Safety" on page 7.

## Installation Flow Chart

The installation of the AQUAVAR adjustable speed pump controller follows the outline below. The steps must be carried out in the order shown. At the right of each step are references to the detailed information needed for the correct installation of the unit.

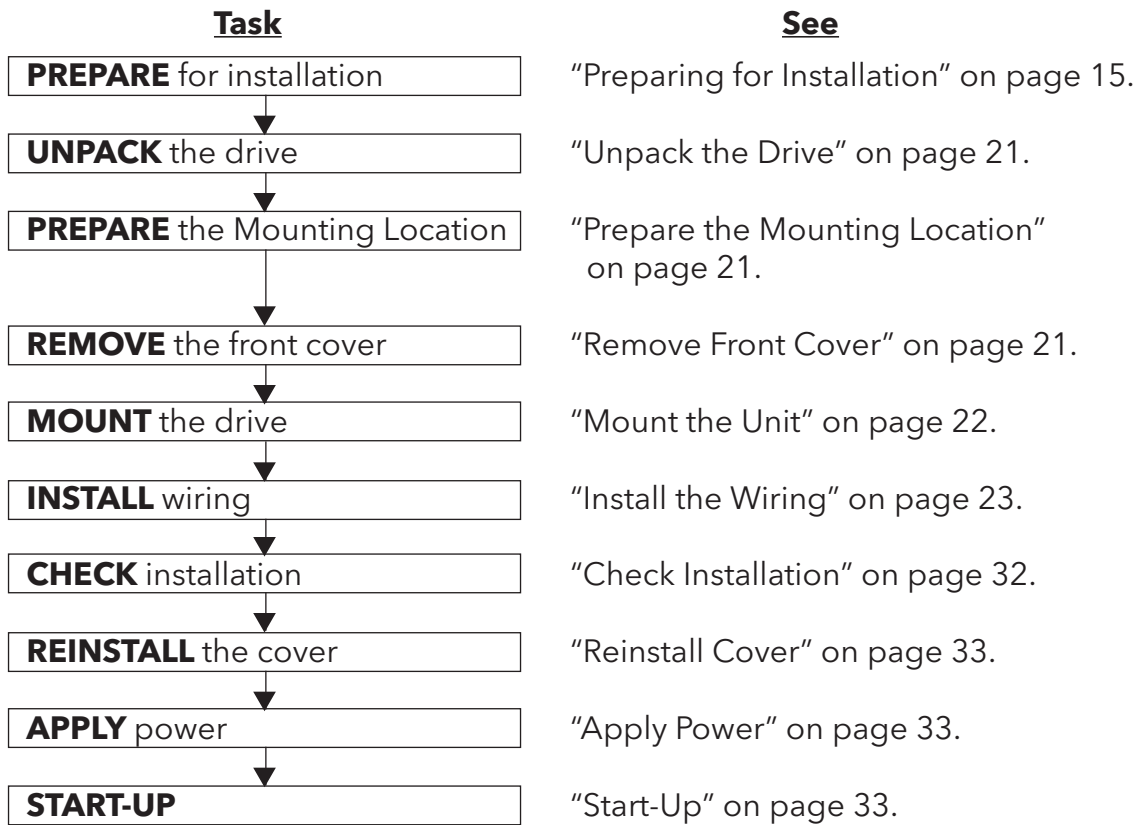

# INTRODUCTION

## AQUAVAR CPC Product Numbering

Voltage	Phase	NEMA 1 Base Model	Full Load Amps Normal Duty	Frame Size	Normal Duty Horsepower
230	1	CPC20071	3.7	R1	1
		CPC20171	8.5	R1	2
		CPC20241	12	R2	3
		CPC20311	15.5	R2	5
		CPC20461	23	R3	7.5
		CPC20591	29.5	R3	10
		CPC20881	44.0	R4	15
		CPC21141	57.0	R4	20
		CPC21431	71.5	R6	25
		CPC21781	89.0	R6	30
		CPC22481	124.0	R6	40
CPC22481	124.0	R6	50		
230	3	CPC20041	4.6	R1	1
		CPC20071	7.5	R1	2
		CPC20121	11.8	R1	3
		CPC20171	16.7	R1	5
		CPC20241	24.2	R2	7.5
		CPC20311	30.8	R2	10
		CPC20461	46.2	R3	15
		CPC20591	59.4	R3	20
		CPC20751	74.8	R4	25
		CPC20881	88.0	R4	30
		CPC21141	114.0	R4	40
		CPC21431	143.0	R6	50
		CPC21781	178.0	R6	60
		CPC22211	221.0	R6	75
		CPC22481	248.0	R6	100
460	3	CPC40061	6.9	R1	3
		CPC40081	8.8	R1	5
		CPC40121	11.9	R1	7.5
		CPC40151	15.4	R2	10
		CPC40231	23	R2	15
		CPC40311	31	R3	20
		CPC40381	38	R3	25
		CPC40451	45	R3	30
		CPC40591	59	R4	40
		CPC40721	72	R4	50
		CPC40781	78	R4	60
		CPC40971	97	R4	75
		CPC41251	125	R5	100
		CPC41571	157	R6	125
		CPC41801	180	R6	150
		CPC42451	245	R7	200
		CPC43161	316	R7	250
		CPC43681	368	R8	300
		CPC44141	414	R8	350
		CPC44861	486	R8	400
CPC45261	526	R8	450		
CPC46021	602	R8	500		
CPC46451	645	R8	550		
575	3	CPC50031	2.7	R2	2
		CPC50041	3.9	R2	3
		CPC50061	6.1	R2	5
		CPC50091	9	R2	7.5
		CPC50111	11	R2	10
		CPC50171	17	R2	15
		CPC50221	22	R2	20
		CPC50271	27	R3	25
		CPC50321	32	R4	30
		CPC50411	41	R4	40
		CPC50521	52	R4	50
		CPC50621	62	R4	60
		CPC50771	77	R6	75
		CPC50991	99	R6	100
		CPC51251	125	R6	125
CPC51441	144	R6	150		

\*\*\* - HP classifications are for reference purposes only, always size the Aquavar according to the output amps and the service factor amps of the motor.

# INTRODUCTION

## Preparing for Installation

### Drive Identification

#### Drive Labels

To determine the type of drive you are installing, refer to either:

- Serial number label attached on upper part of the chokeplate between the mounting holes.

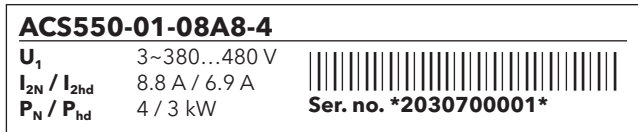

- Type code label attached on the heat sink - on the right side of the unit cover.

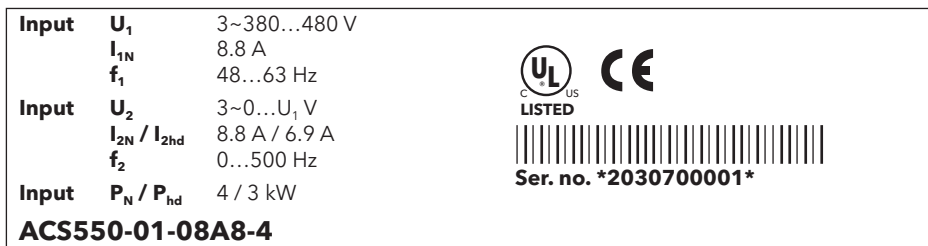

#### Type Code

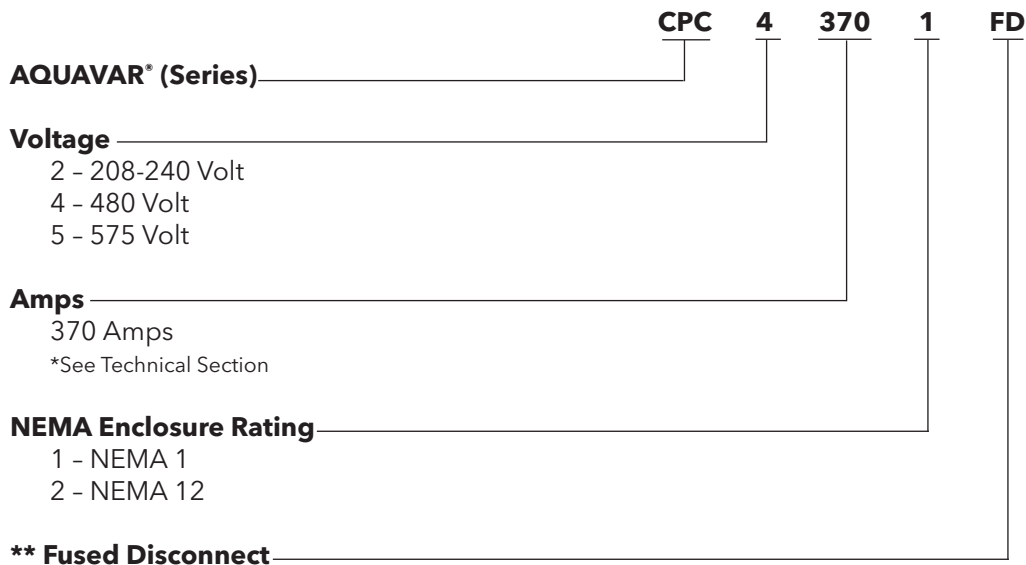

#### Options

\* Consult factory for other options, if available. Not all combinations may be available.

\*\* Standard equipment on 200 HP and above 460 volt models.



# INTRODUCTION

## Ratings and Frame Size

The chart in “Ratings” on page 131 lists technical specifications, and identifies the drive’s frame size - significant, since some instructions in this document, vary, depending on the drive’s frame size. To read the Ratings table, you need the “Output current rating” entry from the type code. Also, when using the Ratings table, note that the table is broken into sections based on the drive’s “Voltage rating”.

## Motor Compatibility

The motor, drive and supply power must be compatible:

Motor Specification	Verify	Reference
Motor type	3-phase induction motor	NEMA MG1
Nominal current	Motor value is within this range: $0.2...2.0 * I_{2hd}$ ( $I_{2hd}$ = drive heavy duty)	<ul style="list-style-type: none"> <li>Type code label on drive, entry for Output Current or</li> <li>Type code on drive and rating current table in “Technical Data” on page 131.</li> </ul>
Nominal frequency	50 - 70 Hz	–
Voltage range	Motor is compatible with the AQUAVAR voltage range.	208...240 V (for CPC2XXXX) or 380...480 V (for CPC4XXXX)

## Tools Required

To install the AQUAVAR you need the following:

- True RMS multimeter
- Screwdrivers (as appropriate for the mounting hardware used)
- Wire stripper
- Tape measure
- Drill
- Mounting hardware: screws or nuts and bolts, four each. The type of hardware depends on the mounting surface and the frame size:

Frame Size	Mounting Hardware	
R1...R4	M5	#10
R5	M6	¼ in.
R6	M8	5/16 in.

## Suitable Environment and Enclosure

Confirm that the site meets the environmental requirements. To prevent damage prior to installation, store and transport the drive according to the environmental requirements specified for storage and transportation. See “Ambient Conditions” on page 145.

Confirm that the enclosure is appropriate, based on the site contamination level:

- IP 21 / UL type 1 enclosure, indoor use only. The site must be free of airborne dust, corrosive gases or liquids, and conductive contaminants such as condensation, carbon dust and metallic particles.

# INTRODUCTION

- IP 54 / UL type 12 enclosure, indoor use only. This enclosure provides protection from airborne dust and light sprays or splashing water from all directions.
- UL Type 3R- Enclosures are intended for outdoor use to provide a degree of protection from falling rain. Undamaged by the formation of ice on the enclosure. May be cooled by forced air and louvers for vents.
- IP 56 / UL type 4 enclosure. Constructed for outdoor use or hose down applications. Provides a degree of protection against falling dirt, rain, sleet, snow, windblown dust and splashing water. Not suitable for direct sun. A sun shield or canopy may be required.

## Suitable Mounting Location

Confirm that the mounting location meets the following constraints:

- The drive must be mounted vertically on a smooth, solid surface, and in a suitable environment as defined above.
- The minimum space requirements for the drive are the outside dimensions (see "Outside Dimensions" on page 141 and 143), plus air flow space around the unit (see "Cooling" on page 137).
- The distance between the motor and the drive is limited by the maximum motor cable length. See "Motor Connection" on page 136.
- The mounting site must support the drive's modest weight and noise output. See "Dimensions and Weights" on page 141.

## Wiring and EMC Considerations

Determine electromagnetic compliance (EMC) requirements per local codes. In general, always follow the NEC in the absence of a local code.

- Follow local codes for cable size, conduit, grounding and motors.
- Keep these four classes of wiring separated: input power wiring, motor wiring, control/communications wiring. Always use separate conduit for motor/control wires.
- Refer to the specifications/recommendations in:  
"Cable Sizing/Rating" on page 131, "Cable Terminals" on page 135, "Input Power (Mains) Connection" on page 136 and "Motor Connection" on page 136.
- Multiple motor wire should always be run in separate conduit. Shielded and grounded!

## Control Cables

### General Recommendations

Use shielded cables, temperature rated at 60° C (140° F) or above:

- Control cables must be multi-core cables with a braided copper wire screen.

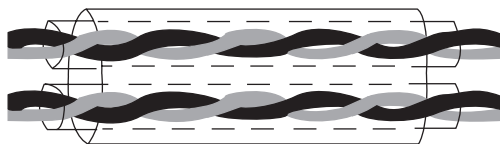

Double Shielded

Example: JAMAK by Draka NK Cables

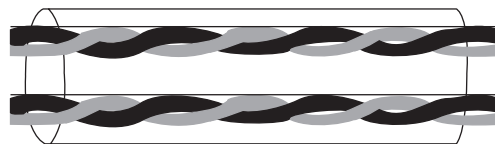

Single Shielded

Example: NOMAK by Draka NK Cables

- The screen must be twisted together into a bundle not longer than five times its width and connected to terminal X1-1 (for digital and analog I/O cables) or to either X1-28 or X1-32 (for RS485 cables).

# INTRODUCTION

Route control cables to minimize radiation to the cable:

- Route as far away as possible from the input power and motor cables (at least 20 cm (8 in)).
- Where control cables must cross power cables make sure they are at an angle as near 90° as possible.
- Stay at least 20 cm (8 in) from the sides of the drive.

Use care in mixing signal types on the same cable:

- Do not mix analog and digital input signals on the same cable.
- Run relay-controlled signals as twisted pairs (especially if voltage > 48 V). Relay-controlled signals using less than 48 V can be run in the same cables as digital input signals.

**NOTE!** Never mix 24 VDC and AC power signals in the same cable.

## *Analog Cables*

Recommendations for analog signal runs:

- Use double shielded, twisted pair cable
- Use one individually shielded pair for each signal.
- Do not use a common return for different analog signals.

## *Digital Cables*

Recommendations for digital signal runs:

- A double shielded cable is the best alternative, but single shielded twisted multi-pair cable is also usable.

## *Control Panel Cable*

If the control panel is connected to the drive with a cable, use only Category 5 Patch ethernet cable.

# INSTALLATION (Frames R1-R6)

## Supply Connection

### Disconnecting Device (Mains)

Install a hand-operated input disconnecting device between the AC power source (MCC) and the drive. The disconnecting device must be of a type that can be locked to the open position for installation and maintenance work. Follow all local NEC codes.

### Fuses

See Technical Data: Fuse Sizing/Rating on pages 133 and 134.

### Thermal Overload and Short-circuit Protection

The drive protects itself and the input and motor cables against thermal overload when the cables are dimensioned according to the nominal current of the drive. No additional thermal protection devices are needed.



**WARNING!** If the drive is connected to multiple motors, a separate thermal overload switch or a circuit breaker must be used for protecting each cable and motor. These devices may require a separate fuse to cut off the short-circuit current.

The drive protects the motor cable and the motor in a short-circuit situation when the motor cable is dimensioned according to the nominal current of the drive.

### Mains Cable (AC line cable) Short-circuit Protection

Always protect the input cable with fuses. Standard gG (US: T or L) very fast acting, fuses will protect the input cable in short-circuit situations and prevent damage to adjoining equipment in case of a short-circuit inside the drive.

Size the fuses according to local safety regulations, appropriate input voltage and the rated current of the drive. For fuse ratings, see Technical Data, pages 133 and 134.



**WARNING!** Circuit breakers are not capable of providing sufficient protection because they are inherently slower than fuses. Always use fuses with circuit breakers, if you are not sure of the circuit braking capacity and mains short circuit power.

### Ground Fault Protection

The drive is equipped with an internal ground fault protective function to protect the unit against ground faults in the motor and the motor cable. This is not a personal safety or a fire protection feature. The ground fault protective function can be disabled with a parameter contact factory for more information.

The EMC filter of the drive includes capacitors connected between the main circuit and the frame. These capacitors and long motor cables increase the ground leakage current and may cause fault current circuit breakers to function.

### Emergency Off Devices

For safety reasons, install the emergency off devices at each operator control station and at other operating stations where emergency off may be needed. Pressing the stop key (⏹) on the control panel of the drive does not generate an emergency off of the motor or separate the drive from dangerous potential.

# INSTALLATION (Frames R1-R6)

## Selecting the Power Cables (copper only)

### General Rules

Dimension the mains (input power) and motor cables according to local regulations:

- Do not use aluminum wires.
- The cable must be able to carry the drive load current. See Technical Data for the rated currents.
- The cable must be rated for at least 70° C (158° F) maximum permissible temperature of conductor in continuous use. For US, follow local codes for cable size, or refer to NEC table 310.16.
- The inductance and impedance of the PE conductor/cable (grounding wire) must be rated according to permissible touch voltage appearing under fault conditions (so that the fault point voltage will not rise excessively when an ground fault occurs).
- 600 VAC cable is accepted for up to 500 VAC concerning the entire AQUAVAR CPC range.

For frame sizes R7 and R8, symmetrical shielded motor cable must be used (figure below). A four-conductor system used up to 30 kW motors cannot be used.

Compared to a four conductor system, the use of symmetrical shielded cable reduces electromagnetic emission of the whole drive system as well as motor bearing currents and wear of bearings.

The motor cable and its PE pigtail (twisted screen) should be kept as short as possible in order to reduce electromagnetic emission as well as capacitive current.

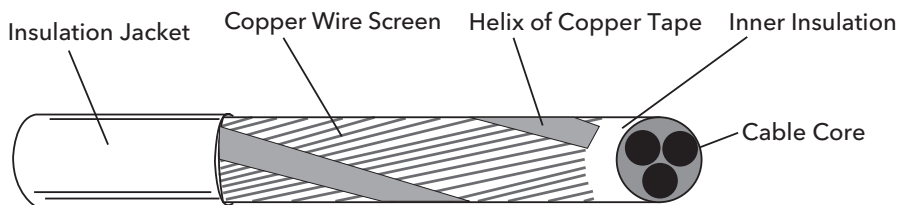

### Motor Cable Shield

To effectively suppress radiated and conducted radio-frequency emissions, the shield conductivity must be at least 1/10 of the phase conductivity. The requirements are easily met with a copper or aluminum shield. The minimum requirement of the motor cable shield of the drive is shown below. It consists of a concentric layer of copper wires with an open helix of copper tape. The better and tighter the shield, the lower the emission level and the bearing currents.

### Additional US Requirements

Type MC continuous corrugated aluminum armor cable with symmetrical grounds or shielded power cable must be used for the motor cables **if metallic conduit is not used**. For the North American market, 600 VAC cable is accepted for up to 500 VAC. For drives rated over 100 amperes, the power cables must be rated for 70°C (158°F).

# INSTALLATION (Frames R1-R6)

## Conduit

Where conduits must be coupled together, bridge the joint with a ground conductor bonded to the conduit on each side of the joint. Bond the conduits also to the drive enclosure. Use separate conduits for input power, motor, brake resistors, and control wiring. **Do not run motor wiring from more than one drive in the same conduit.**

## Armored cable / shielded power cable

The motor cables can be run in the same cable tray as other 460 V power wiring. Control and signal cables must not be run in the same tray as power cables. Six conductor (3 phases and 3 ground) type MC continuous corrugated aluminum armor cable with symmetrical grounds is available from the following suppliers (tradenames in parenthesis):

- Anixter Wire & Cable (Philsheath)
- BICC General Corp (Philsheath)
- Rockbestos Co. (Gardex)
- Oaknite (CLX).

Shielded power cables are available from Belden, LAPPKABEL (OLEFLEX) and Pirelli.

## Installing the Drive



**WARNING!** Before installing the AQUAVAR, ensure the input power supply to the drive is off.

### Unpack the Drive

1. Unpack the drive.
2. Check for any damage and notify the shipper immediately if damaged components are found.
3. Check the contents against the order and the shipping label to verify that all parts have been received.

### Prepare the Mounting Location

The AQUAVAR should only be mounted where all of the requirements defined "Preparing for Installation" on page 15 are met.

1. Mark the position of the mounting holes. Refer to page 138 for mounting hole location.
2. Drill the holes.

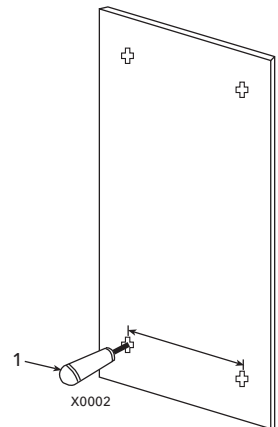

**NOTE!** Frame sizes R3 and R4 have four holes along the top. Use only two. If possible, use the two outside holes (to allow room to remove the fan for maintenance).

### Remove Front Cover

#### IP 21 / UL Type 1

1. Remove the control panel, if attached.
2. Loosen the captive screw at the top.
3. Pull near the top to remove the cover.

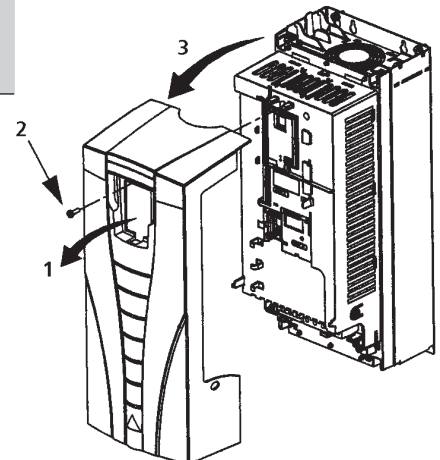

# INSTALLATION (Frames R1-R6)

## IP 54 / UL Type 12

1. If hood is present: Remove screws (2) holding hood in place.
2. If hood is present: Slide hood up and off of the cover.
3. Loosen the captive screws around the edge of the cover.
4. Remove the cover.

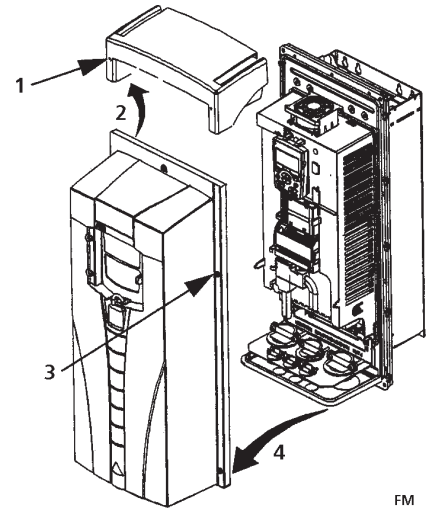

## Mount the Drive

### IP 21 / UL Type 1

1. Position the AQUAVAR onto the mounting screws or bolts and securely tighten in all four corners.

**NOTE!** Lift the AQUAVAR by its metal chassis.

2. Non-English speaking locations: Add a warning sticker in the appropriate language over the existing warning on the top of the module.

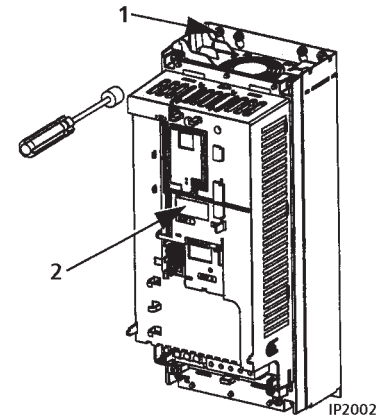

### IP 54 / UL Type 12

For the IP54 / UL Type 12 enclosures, rubber plugs are required in the holes provided for access to the drive mounting slots.

1. As required for access, remove the rubber plugs. Push plugs out from the back of the drive.
2. Position the AQUAVAR onto the mounting screws or bolts and securely tighten in all four corners.

**NOTE!** Lift the AQUAVAR by its metal chassis.

3. Reinstall the rubber plugs.
4. Non-English speaking locations: Add a warning sticker in the appropriate language over the existing warning on the top of the module.

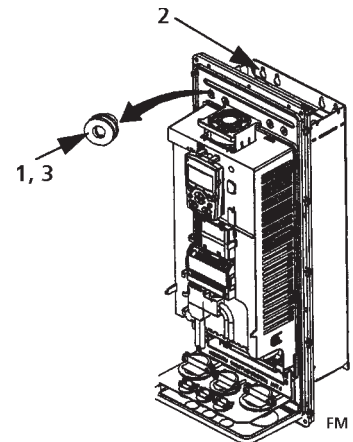



# INSTALLATION (Frames R1-R6)

## Install the Wiring

### *Conduit/Gland Kit*

Wiring drives with the IP 21 / UL type 1 Enclosure requires a conduit/gland kit with the following items:

- Conduit/gland box
- Screws
- Cover

The kit is included with IP 21 / UL type 1 Enclosures.

### *Overview*

As you install the wiring, observe the following:

- There are four sets of wiring instructions - one set for each combination of drive enclosure type (IP 21 / UL type 1 and IP 54 / UL type 12), and wiring type (conduit or cable). Be sure to select the appropriate procedure.
- "Connection Diagrams" on page 24 shows the connection points on the drive.
- "Power Connections" on page 29 describes specific instructions for wiring the power. Use in combination with the appropriate general procedure.
- "Control Connections" on page 29 describes specific instructions for wiring the control. Use in combination with the appropriate general procedure.
- "Cable Terminals" on page 135 list the recommended tightening torques.
- Where applicable, observe EMC recommendations. For example, properly ground the wire screen cable shields.

# INSTALLATION (Frames R1-R6)

## Three Phase Wiring/Connection Diagrams

The layout of connection terminals is similar for all frame sizes (R1...R6). The only significant layout difference is in the power and ground terminals for frame sizes R5 and R6. The following diagrams show:

- Terminal layout for frame size R3, which, in general, applies to all frame sizes except as noted above.
- Power and ground terminal layout for frame sizes R5 and R6.

Diagram shows the R3 frame. Other frames have similar layouts.

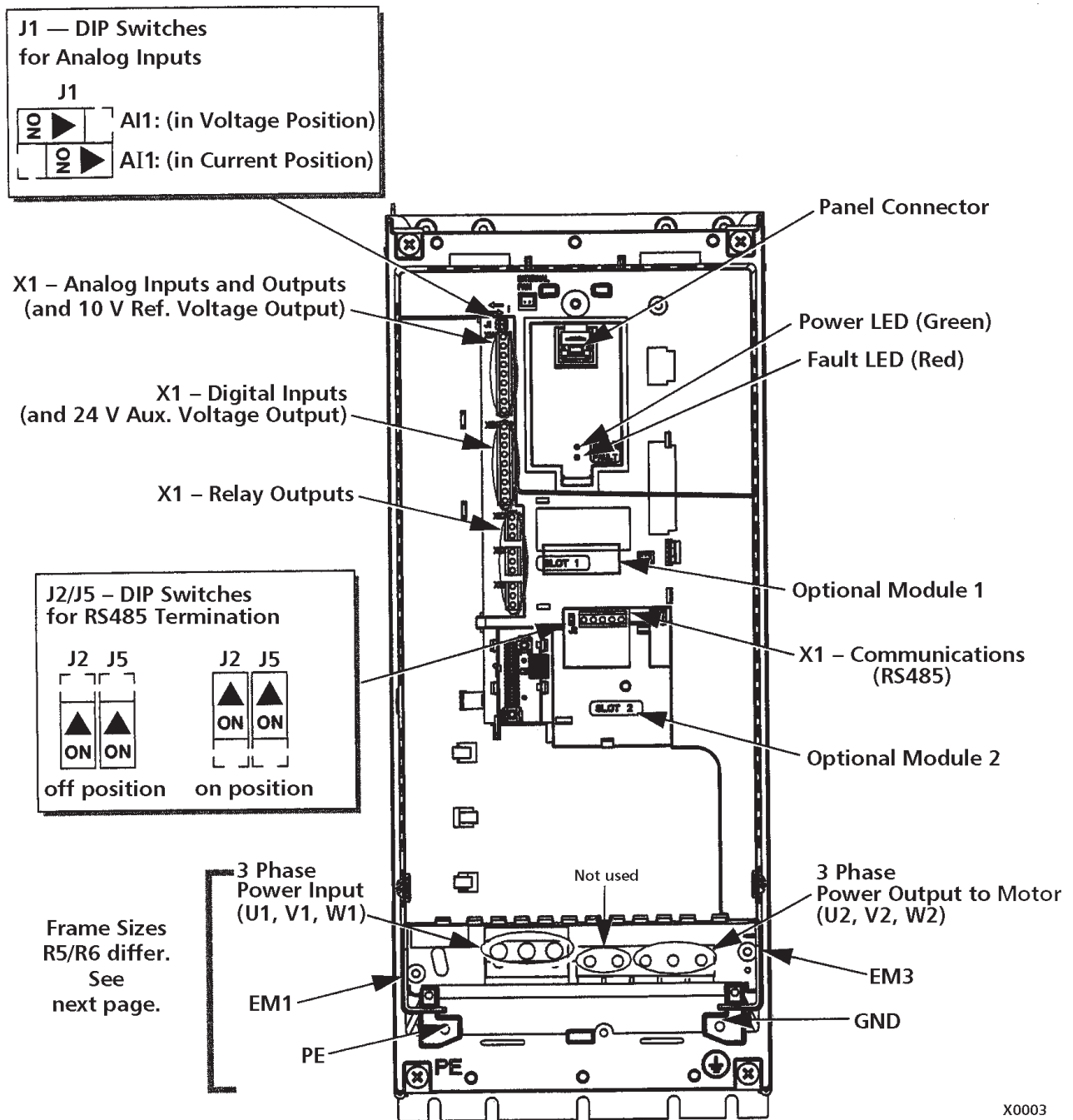

**WARNING!** For floating networks remove screws at EM1 and EM3.

# INSTALLATION (Frames R1-R6)

## Three Phase Wiring/Connection Diagrams *continued*

Frame Size R5

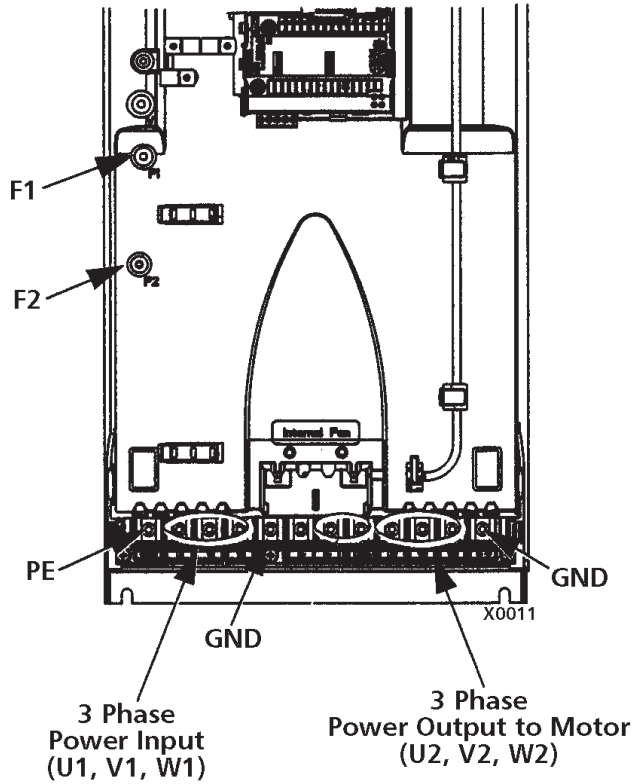

Frame Size R6

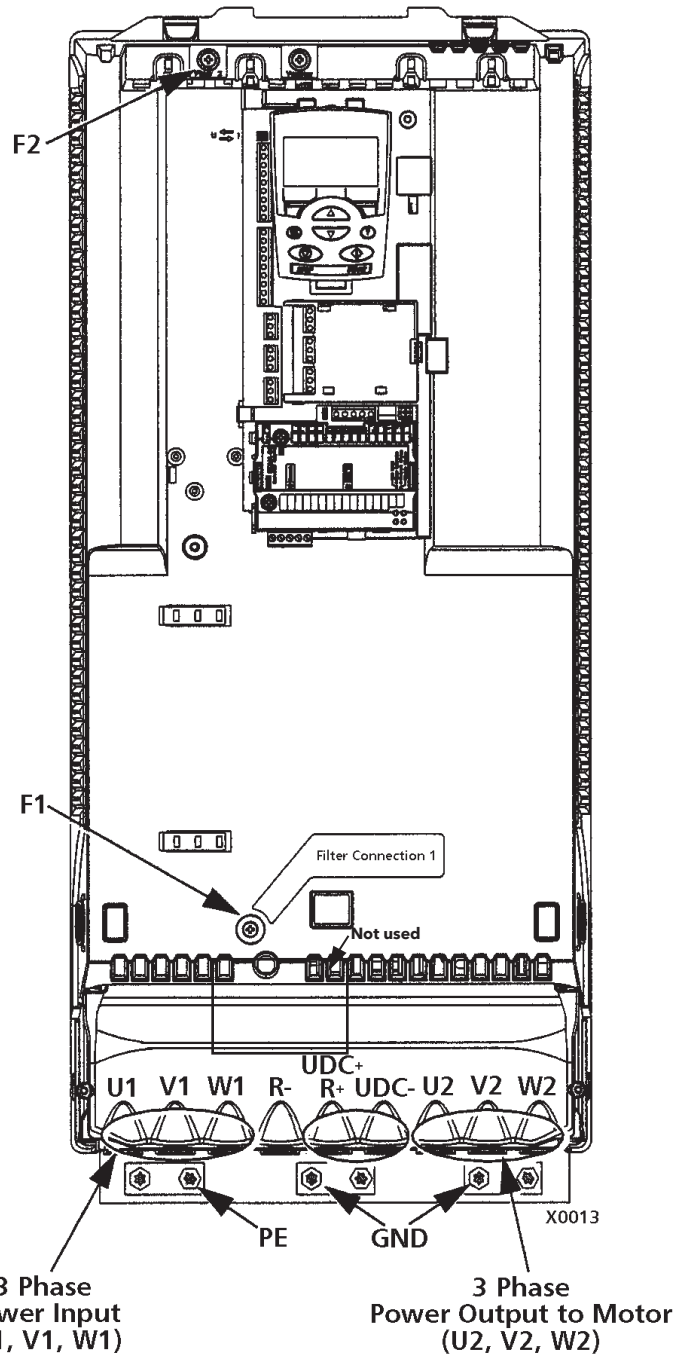

**WARNING!** For floating networks remove screws at F1 and F2.

# INSTALLATION (Frames R1-R6)

## Single Phase Wiring/Connection Diagram

Diagram shows the R3 frame. Other frames have similar layouts.

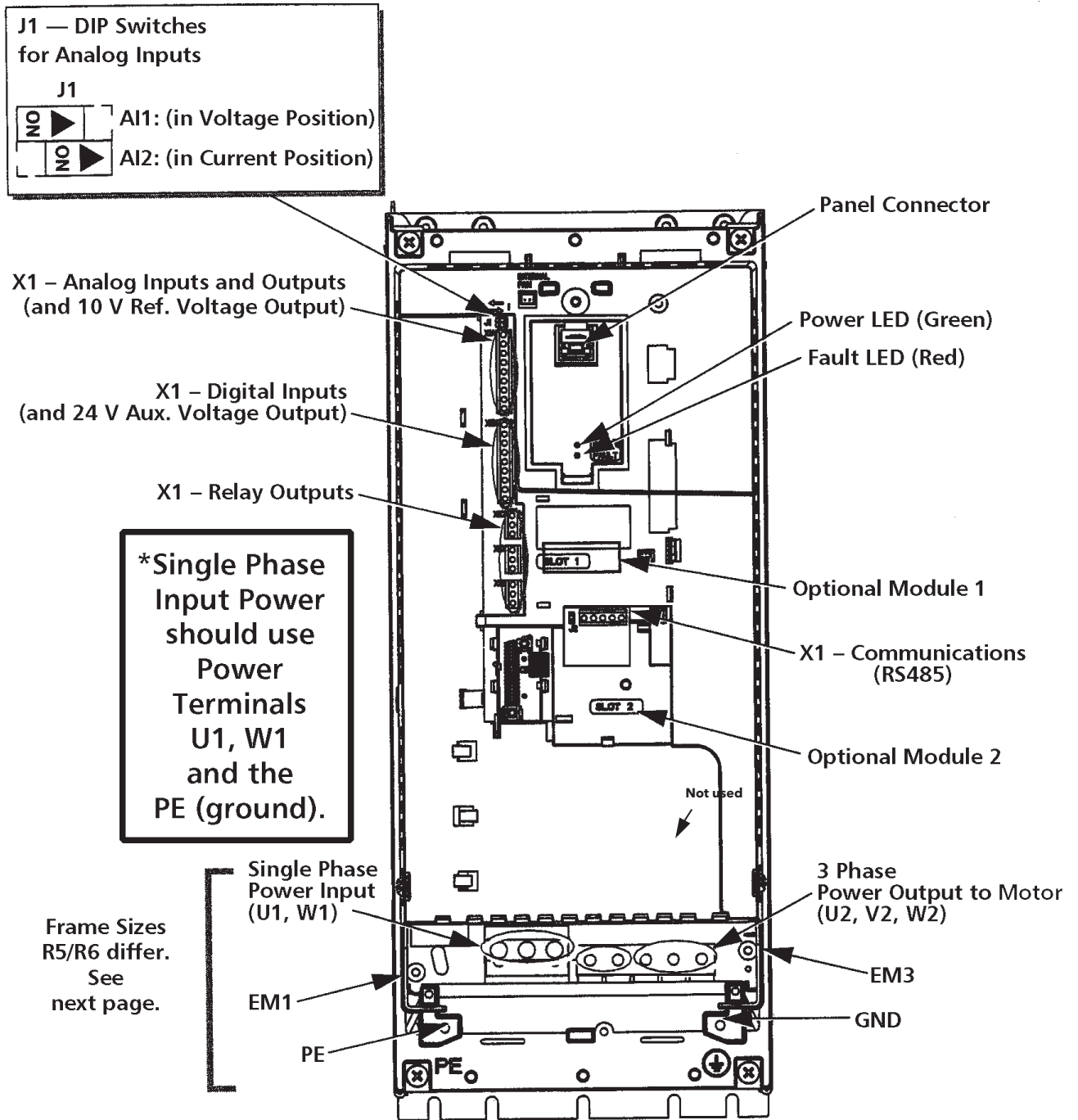

**WARNING!** For floating networks remove screws at EM1 and EM2.



**WARNING!** For single phase wiring, derate the 3 phase nominal HP and amps 50%.

# INSTALLATION (Frames R1-R6)

## Wiring IP 21 / UL Type 1 Enclosure with Conduit

1. Open the appropriate knockouts in the conduit/gland box.
2. Install thin-wall conduit clamps (not supplied).
3. Install conduit/gland box.
4. Connect conduit runs to box. Always follow appropriate NEC or local electrical codes for inverter drives, motor wiring.
5. Route input power and motor wiring through conduits. Preferably metal, grounded type.
6. Strip wires.
7. Connect power, motor, and ground wires to the drive terminals. See "Power Connections" on page 29.
8. Route the control cable, transducer cable through the conduit.
9. Strip the control cable sheathing and twist the copper screen into a pigtail.
10. Connect the transducer screen pigtail for digital and analog I/O cables at X1-1.
11. Strip and connect the individual control wires to the drive terminals. See "Control Connections" on page 29. Including transducer.
12. Install the conduit/gland box cover (1 screw).
13. Wire transducer leads to analog 2, terminal(s) +24V, AI2 and GND.
14. Wire positive lead of transducer to terminal 10 (+24VDC). Color is red or brown.
15. Wire analog lead (negative) to terminal 10 of X1 for 4-20mA signal. Color is white or black.
16. Take the transducer cable screen to X1, #1 Terminal.

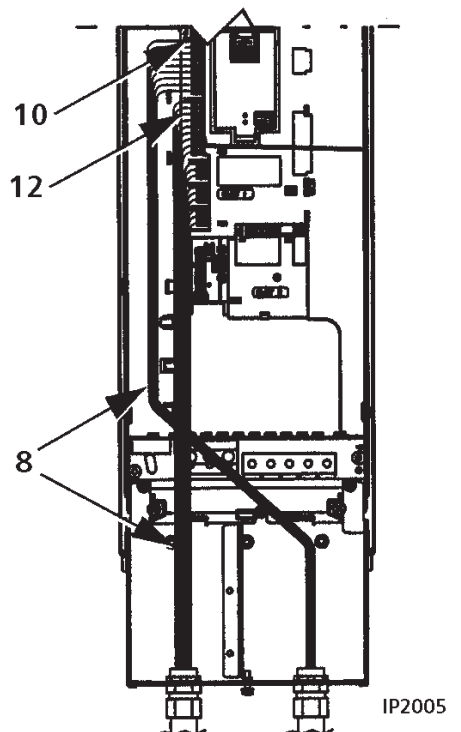
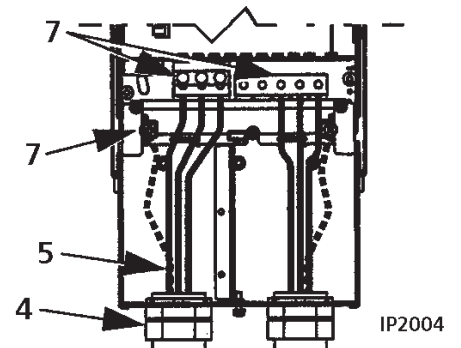
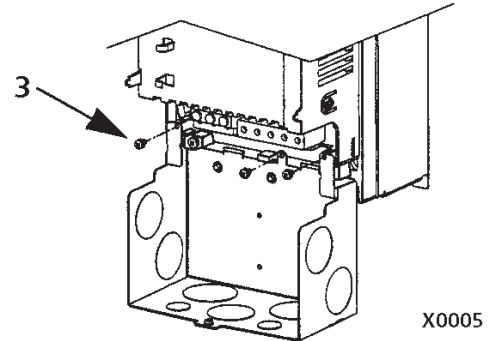
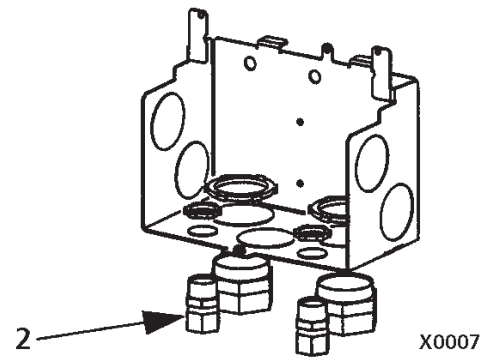

# INSTALLATION (Frames R1-R6)

## Wiring IP 54 / UL Type 12 Enclosure with Conduit

1. Remove and discard the clamping plate.
2. Remove and discard the cable seals where conduit will be installed. (The cable seals are cone-shaped, rubber seals on the bottom of the drive.)
3. For each conduit run, install water tight conduit connectors (not supplied).
4. Route the power wiring through the conduit.
5. Route the motor wiring through the conduit.
6. Strip the wires.
7. Connect the power, motor and ground wires to the drive terminals. See "Power Connections" on page 29.
8. Route the control wiring through the conduit.
9. Strip the control cable sheathing and twist the copper screen into a pigtail.
10. Connect the ground screen pigtail for digital and analog I/O cables X1-1.
11. Strip and connect the individual control wires to the drive terminals. See "Control Connections" on pages 29 and 30.
12. Install the conduit/gland box cover (1 screw).
13. Install and wire transducer as stated in previous steps on pages 27 and 28.

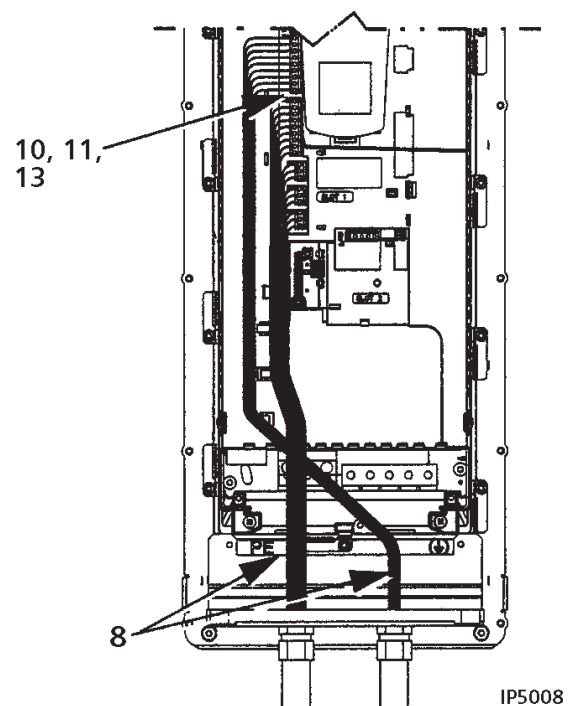
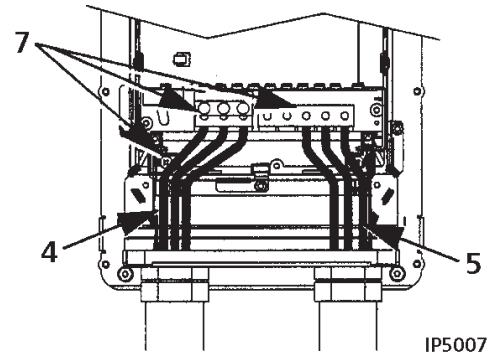
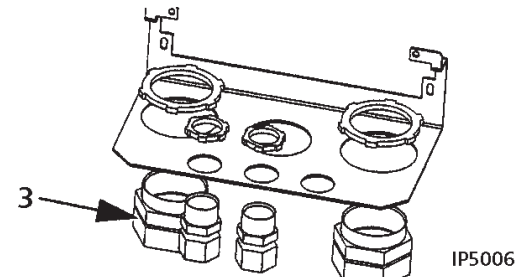
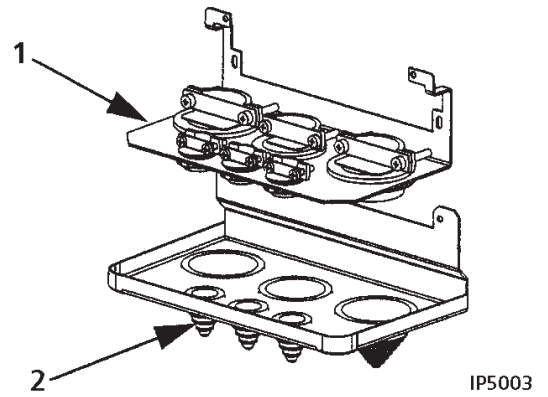

# INSTALLATION (Frames R1-R6)

## Power Connections



**WARNING!** Ensure the motor is compatible for use with the AQUAVAR. The AQUAVAR must be installed by a competent person in accordance with the considerations defined in “Preparing for Installation” on page 15. If in doubt, contact your local AQUAVAR sales or service office. Always consult the NEC for information.

- Refer to the following table to complete the power connections. If appropriate, also perform the instructions for the braking and floating networks.

Terminal	Description	Note
U1, V1, W1*	3-phase power supply input	“Input Power (Mains) Connection” on page 136.
PE	Protective Ground	Follow local rules for cable size.
U2, V2, W2	Power output to motor	“Motor Connection” on page 136.

\* **NOTE:** The AQUAVAR (208...240V series) can be used with a single phase supply, if output current is derated by 50%. For single phase supply voltage, connect power at U1 and W1. Refer to page 26.

## Floating Networks

For floating networks (also known as IT, ungrounded or high impedance networks):

- Disconnect the internal RFI filter by removing both the EM1 and EM3 screws (frame sizes R1...R4, see page 24), or F1 and F2 screws (frame sizes R5...R6, see page 25).
- Where EMC requirements exist, check for excessive emission propagated to neighboring low voltage networks. In some cases, the natural suppression in transformers and cables is sufficient. If in doubt, use a supply transformer with static screening between the primary and secondary windings.
- Do NOT install an external filter. Using an RFI filter grounds the input power through the filter capacitors, which could be dangerous and could damage the unit.



## Control Connections

To complete the control connections, use:

- Following tables
- “Single/Multipump”
- “Complete Parameter Descriptions”
- Cable recommendations in “Control Cables”



# INSTALLATION (All Frames)

		X1	Control Wiring	
Analog I/O	Transducer Screen/ Shield	1	SCR Terminal for transducer shield. (Connected internally to chassis ground.)	
	Jumper Wire	2	AI1 Analog input channel 1, 2nd transducer. Default <sup>2</sup> = frequency reference. Resolution 0.1%, accuracy ±1%. J1:AI1 OFF: 0...10 V (Ri = 312 kΩ) 	
			J1:AI1 ON: 0...20 mA (Ri = 100 Ω)  Switch positions listed on page 25.	
			3	AGND Analog input circuit common. (Connected internally to chassis gnd. through 1 MW. Jumper wire to X1-11.)
	(-) Transducer (4-20mA) Connection (White or Black)	4	+10 V 10 V/10 mA reference voltage output for analog input potentiometer, accuracy ±2%. (Not used.)	
			5	AI2 Analog input channel 2. Resolution 0.1%, accuracy ±1%. Transducer input 4-20 mA
				6
	Digital Inputs <sup>1</sup>	(+) Transducer Power Supply (Brown or Red)	7	AO1 Analog output, programmable. Default <sup>2</sup> = Not used. Current 0...20 mA (load < 500 Ω)
		Jumper Wire 11 and 12	8	AO2 Analog output, programmable. Default <sup>2</sup> = Not used. 0...20 mA (load < 500 Ω)
9				AGND Analog output circuit common (Connected internally to chassis gnd. through 1 MΩ)
10 - 15 E-stop or Jumper		10	+24V Auxiliary voltage output 24 VDC / 250 mA (reference to GND). Short circuit protected. Transducer/digital input power supply.	
			11	GND Auxiliary voltage output common. (Connected internally as floating.)
Relay Outputs		E-stop/start Jump to +24V for enable (15 to 10 Jumper)	12	DCOM Digital input common. To activate a digital input, there must be ≥+10 V (or ≤-10 V) between that input and DCOM. The 24 V may be provided by the AQUAVAR (X1-10) or by an external 12...24 V source of either polarity.
			13	DI1 Digital input 1, programmable. Default <sup>2</sup> = run enable (Group 24)
			14	DI2 Digital input 2, programmable. Default <sup>2</sup> = low water (Group 24)
			15	DI3 Digital input 3, programmable. Default <sup>2</sup> = E-stop or jumper
	16		DI4 Digital input 4, programmable. Default <sup>2</sup> = set point selection	
	17		DI5 Digital input 5, programmable. Default <sup>2</sup> = HOA (Group 12)	
	18		DI6 Digital input 6, programmable. Default <sup>2</sup> = not used	
Relay Outputs		19	RO1C Relay output 1, programmable. Default <sup>2</sup> = drive ready	
		20	RO1A Maximum: 250 VAC / 30 VDC, 2 A	
		21	RO1B Minimum: 500 mW (12 V, 10 mA)	
		22	RO2C Relay output 2, programmable. Default <sup>2</sup> = pump run	
		23	RO2A Maximum: 250 VAC / 30 VDC, 2 A	
		24	RO2B Minimum: 500 mW (12 V, 10 mA)	
		25	RO3C Relay output 3, programmable. Default <sup>2</sup> = fault	
		26	RO3A Maximum: 250 VAC / 30 VDC, 2 A	
		27	RO3B Minimum: 500 mW (12 V, 10 mA)	

<sup>1</sup> Digital input impedance 1.5 kΩ. Maximum voltage for digital inputs is 30 V.

<sup>2</sup> Default values depend on the macro used. Values specified are for the default macro, single/multipump.

**NOTE:** Jumper Wires between 3 and 11, 10 and 15, 11 and 12.

**NOTE!** Terminals 3, 6 and 9 are at the same potential.

**NOTE!** For safety reasons the fault relay signals a "fault" when the AQUAVAR is powered down.

# INSTALLATION (Frames R1-R6)

You can wire the digital input terminals in either a PNP or NPN configuration.

PNP Connection (Source)

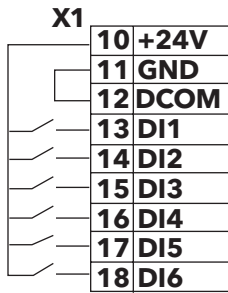

NPN Connection (Sink)

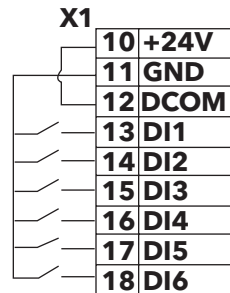

## Communications

Terminals 28...32 are for RS485 or modbus communications. Use shielded cables. For lengths of cable beyond 100 feet, use screen connections.

Do not directly ground the RS485 network at any point. Ground all devices on the network using their corresponding earthing terminals.

As always, the grounding wires should not form any closed loops, and all the devices should be earthed to a common ground.

Terminate the RS485 network using 120 Ω resistors at both ends of the network. Use the DIP switch to connect or disconnect the termination resistors. See following diagram and table.

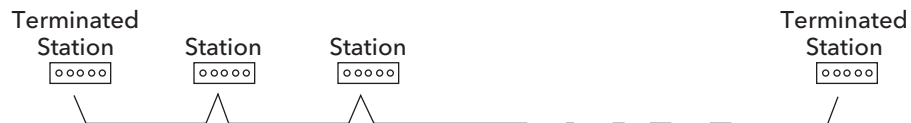

X1	Identification	Hardware Description <sup>1</sup>	
28	Screen	<b>RS485 Multidrop Application Other Modbus Devices</b> 	<b>RS485 Interface</b>  off position    on position <b>Bus Termination</b>
29	B		
30	A		
31	AGND		
32	Screen		

RS485 Multipump Connections

<sup>1</sup> For functional descriptions, see "Standard Serial Communication" addendum.

# INSTALLATION (Frames R1-R6)

## Check Installation

Before applying power, perform the following checks.

√	Check
	Installation environment conforms to the drive's specifications for ambient conditions.
	The drive is mounted securely.
	Space around the drive meets the drive's specifications for cooling.
	The motor and driven equipment are ready for start (3 phase motor).
	For floating networks: The internal RFI filter is disconnected.
	The drive is properly grounded, along with the pump, motor and control panel.
	The input power (mains) voltage matches the drive nominal input voltage (watch for "open delta" power).
	The input power (mains) connections at U1, V1 and W1 are connected and tightened as specified. Loose connections may cause arcing!
	The input power (mains) fuses are installed, according to NEC.
	The motor connections at U2, V2 and W2 are connected and tightened as specified.
	The motor cable is routed away from other cables and in separate conduit.
	NO power factor compensation capacitors are in the motor cable.
	The control connections are connected and tightened as specified.
	NO tools or foreign objects (such as drill shavings) are inside the drive.
	NO alternate power source for the motor (such as a bypass connection) is connected - no voltage is applied to the output of the drive.
	Single phase power is connected to U1 and W1 with GND.

# INSTALLATION (Frames R1-R6)

## Reinstall Cover

### IP 21 / UL Type 1

1. Align the cover and slide it on.
2. Tighten the captive screw.
3. Reinstall the control panel.

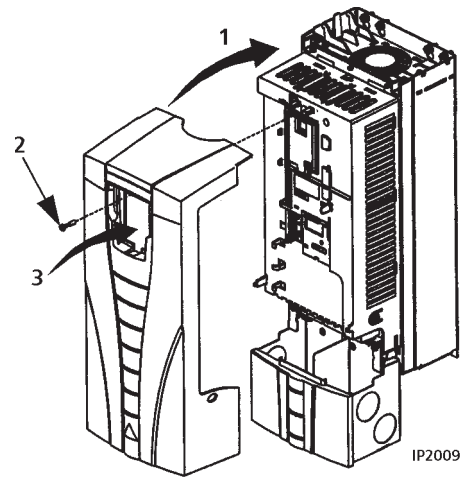

### IP 54 / UL Type 12

1. Align the cover and slide it on.
2. Tighten the captive screws around the edge of the cover.
3. Slide the hood down over the top of the cover.
4. Install the two screws that attach the hood.
5. Reinstall the control panel.

**NOTE!** The control panel window must be closed to comply with IP 54/UL type 12.

6. Optional: Add a lock (not supplied) to secure the control panel window.

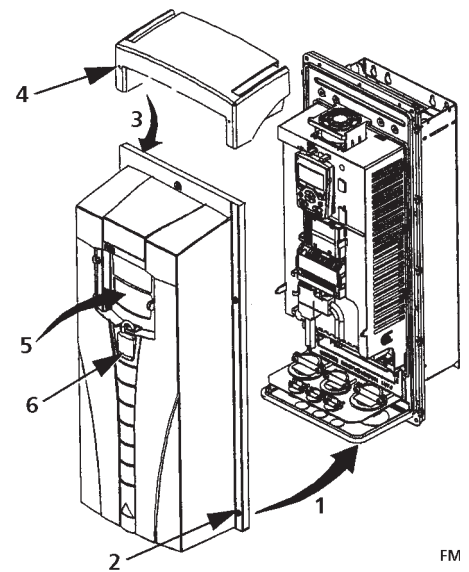

## Apply Power

Always reinstall the front cover before turning power on.



**WARNING!** The AQUAVAR will start up automatically at power up, if the external run command is on.

1. Apply input power.  
When power is applied to the AQUAVAR, the green LED comes on.

**NOTE!** Before increasing motor speed, check that the motor is running in the desired direction.

## Start-Up

The AQUAVAR has default parameter settings that are sufficient for many situations. However, review the following situations. Perform the associated procedures as appropriate. Proceed to Start-Up section of this manual.

# INSTALLATION (Frames R7-R8)

## AQUAVAR Drive Manuals

### GENERAL MANUALS

---

#### AQUAVAR User's Manual (IOM) (1...150 HP)

- Safety
- Installation
- Start-Up
- Diagnostics
- Maintenance
- Technical Data

#### AQUAVAR User's Manual (IOM) (200...550 HP)

- Safety
- Installation
- Start-Up
- Diagnostics
- Maintenance
- Technical Data

### OPTION MANUALS

---

(Fieldbus Adapters, I/O Extension Modules etc., manuals delivered with optional equipment.)

#### Relay Output Extension Module (typical title)

- Installation
- Start-Up
- Diagnostics
- Technical Data



# INSTALLATION (Frames R7-R8)

## Introduction

AQUAVAR CPC drives include an extension module that is not covered in the AQUAVAR User's Manual. The extension module is attached to the drive module at the factory, which includes fusible disconnect.

This supplement provides the additional extension module information required for AQUAVAR drives:

- Additional installation steps and considerations.
- Steps for separating the drive from the extension module for drive service access.
- Dimensions for the extension module.

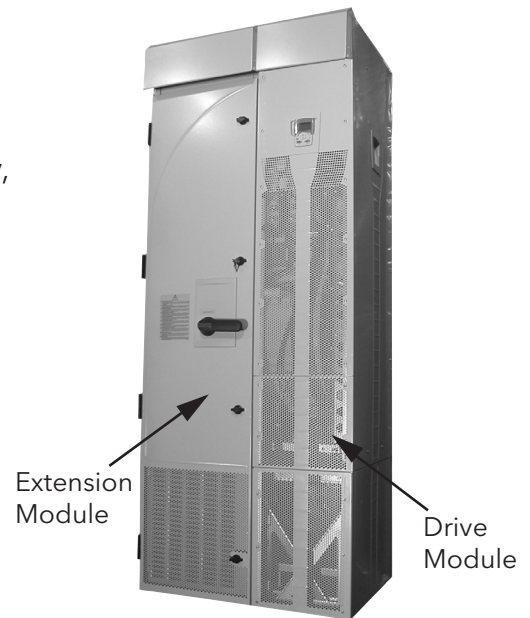

**WARNING!** Only qualified electricians are allowed to carry out the work described in this chapter. Follow requirements in "Safety" on the first pages of this manual. Ignoring the safety instructions can cause injury or death.

## Planning

When planning for cable/conduit routing, refer to the AQUAVAR User's Manual, but note that, for the AQUAVAR, all connections are routed through the top of the extension module.

## Moving the Unit

1. Move the transport package by pallet truck to the installation site.
2. Unpack the transport package.
3. To position the unit, use a lift, connected as shown.

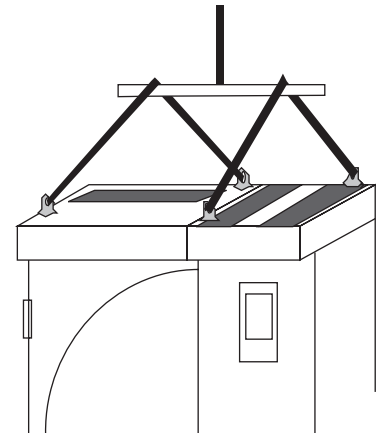

## Mounting

### Fastening the Unit

See the "Dimensional Drawings" on page 41 for the exact locations of the mounting points.

1. Use at least four screws - two at the front, two at the back - to attach the unit base plate to the floor.
2. Use at least two screws to attach the back of the enclosure to a wall.

There are two holes available at the top of each: the extension module and the drive module.

# INSTALLATION (Frames R7-R8)

## Connecting Power and Control Cables

Additional considerations that apply with the enclosure extension:

- The power cable connection diagram that applies for the AQUAVAR is:

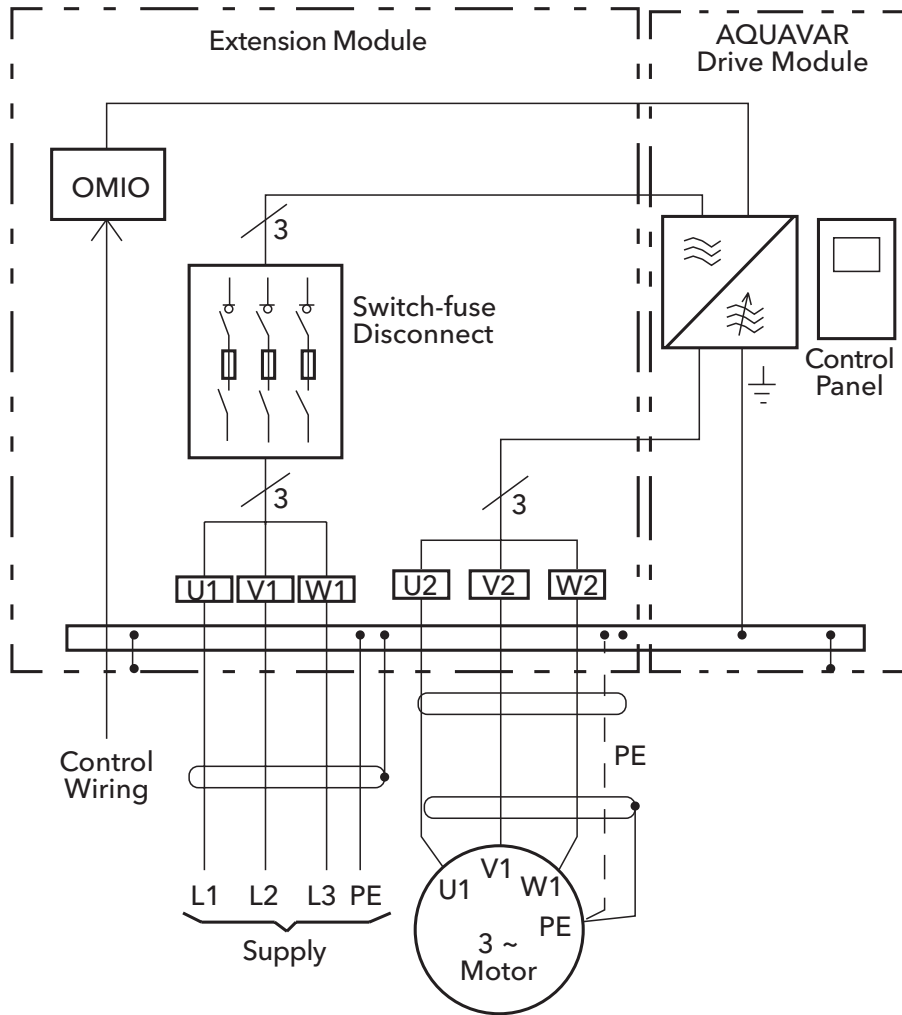

- Temporarily remove the upper high voltage shield (clear plastic) to gain access to the power connections in the extension module.
- To avoid metal shavings inside the cabinet, temporarily remove the gland/conduit plate at the top of the extension module. Then drill holes and mount conduit or cable fittings as needed.
- Route all power and control wiring through the top of the extension module.



# INSTALLATION (Frames R7-R8)

- The following diagram shows the power and control connection points in the enclosure module supplied with the R7 drive module.

## R7 Frame Size

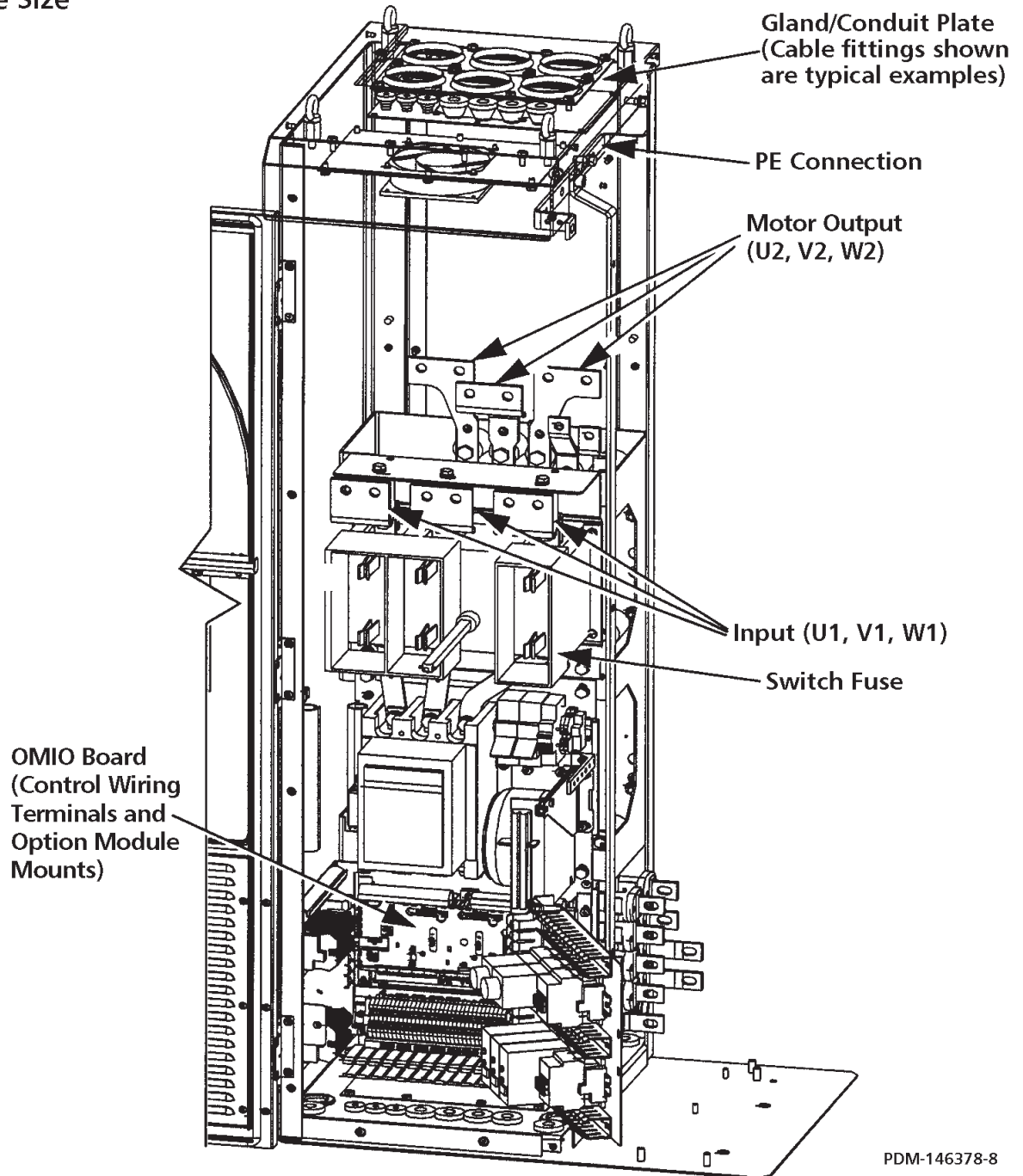



# INSTALLATION (Frames R7-R8)

- The following diagram shows the power and control connection points in the enclosure module supplied with the R8 drive module.

R8 Frame Size

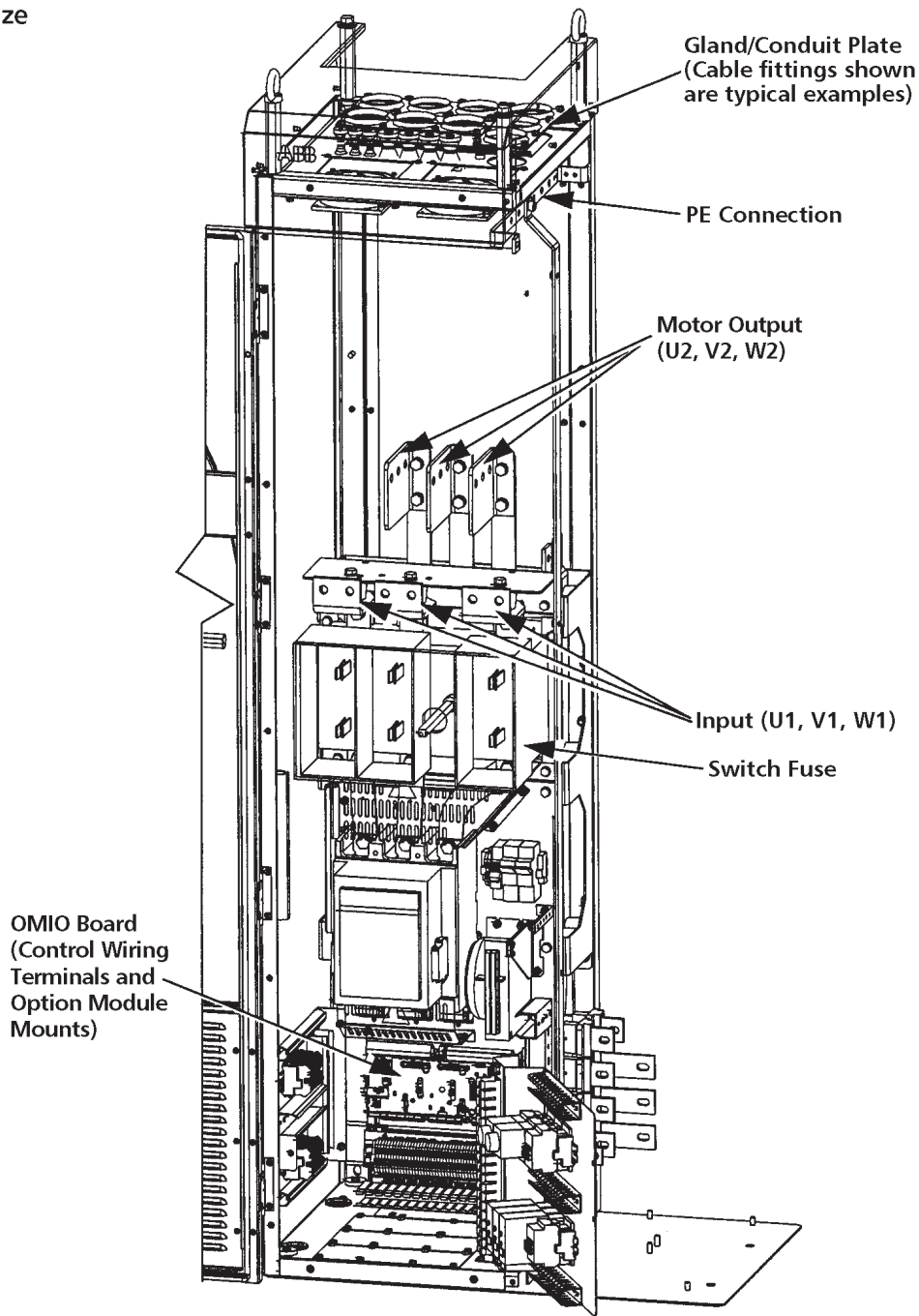

- Re-mount the high voltage shield.

 **WARNING!** Always replace all high voltage shields before applying power.

- See the AQUAVAR User's Manual for detailed instructions on control connections, installation check list and drive start-up process.

# INSTALLATION (Frames R7-R8)

## Maintenance

This section describes the procedure for separating the drive and extension modules, which is required to provide service access to the drive module.

## Safety



**WARNING!** Read "Safety" on the first pages of this manual before performing any maintenance on the equipment. Ignoring the safety instructions can cause injury or death. **Note:** There are parts carrying dangerous voltages near the OMIO board when the drive is powered.

## Separating the Drive and Extension Modules

The drive module is mounted on a trolley that straddles a pedestal. The following procedure removes mechanical connections so that the drive module and trolley can roll forward for service access.

1. Disconnect all power sources from the drive/extension modules and **wait at least 5 minutes for internal capacitors to fully discharge.**
2. Remove all front covers from the drive module.
3. Disconnect the control panel cable.
4. Remove the upper side plate from the drive module if convenient.
5. Remove screws (if any) that fasten the drive module to the wall.
6. Inside the pedestal, toward the rear are screws that attach the drive bus bars to the pedestal bus bars. The connections are staggered for easy access using a wrench with an extension. Remove these screws (6).

Torque when re-assembling:

- R7: M8 (5/16 in) screws, 15...22 Nm (11...16 lb ft)
- R8: M10 (3/8 in) screws, 30...44 Nm (22...32 lb ft)



**WARNING!** Be careful not to drop screws inside the pedestal. Loose metal pieces inside the unit may cause damage.

7. The following cables between the drive and the extension module are split by a connector located at the front of the drive. Disconnect both cables at this location.
  - The power supply cable to the OMIO board.
  - The power supply cable to the extensionmodule cooling fan.
8. At the OTIF board, disconnect the two fiber optic cables. Make note of the terminal colors for use when reconnecting.
9. Carefully remove the cables disconnected in the above steps: Pull the cables down inside the pedestal and bundle them so that they will not get damaged or caught in the trolley when the drive module is wheeled out.

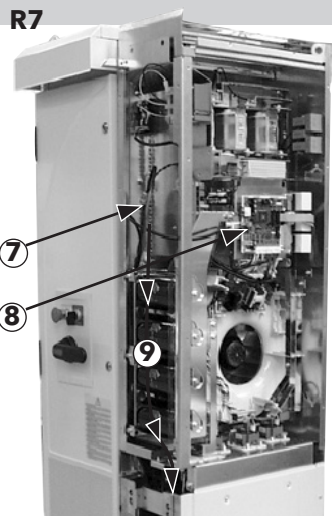

## INSTALLATION (Frames R7-R8)

10. Remove screws fastening the drive module trolley to the pedestal.



**WARNING!** These screws are an important step during re-assembly - the screws are required for grounding the drive.

11. **R8:** The front of the trolley includes support braces that fold out. Lift each brace slightly and fold it out.
12. Remove screws that fasten the drive module to the extension module.



**CAUTION!** The drive module is now separated and could tip over. Use care when moving the drive module.

13. Pull on the handle to wheel the drive module out.

### Drive Maintenance

See the AQUAVAR User's Manual for drive maintenance procedures, page 34.

### Re-Assembly

Re-attach the modules in reverse order to the above.



# INSTALLATION (Frames R7-R8)

## Technical Data

### Dimensional Drawings

See the AQUAVAR User's Manual for drive module dimensions.

### Extension Module R7

Dimensions are listed in millimeters and [inches].

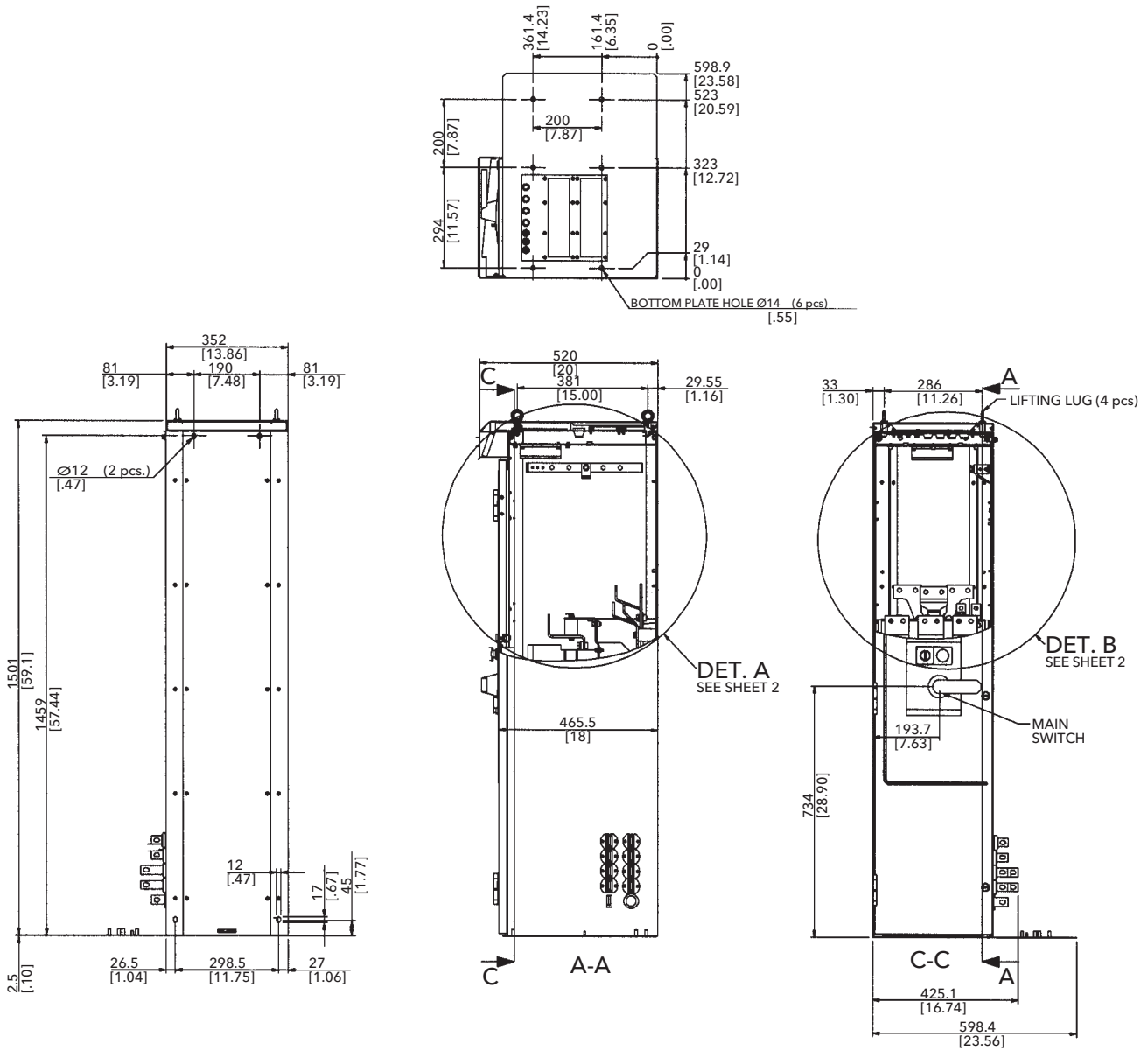

3AFE 64626264 30.04.02

# INSTALLATION (Frames R7-R8)

## Detail R7

Dimensions are listed in millimeters and [inches].

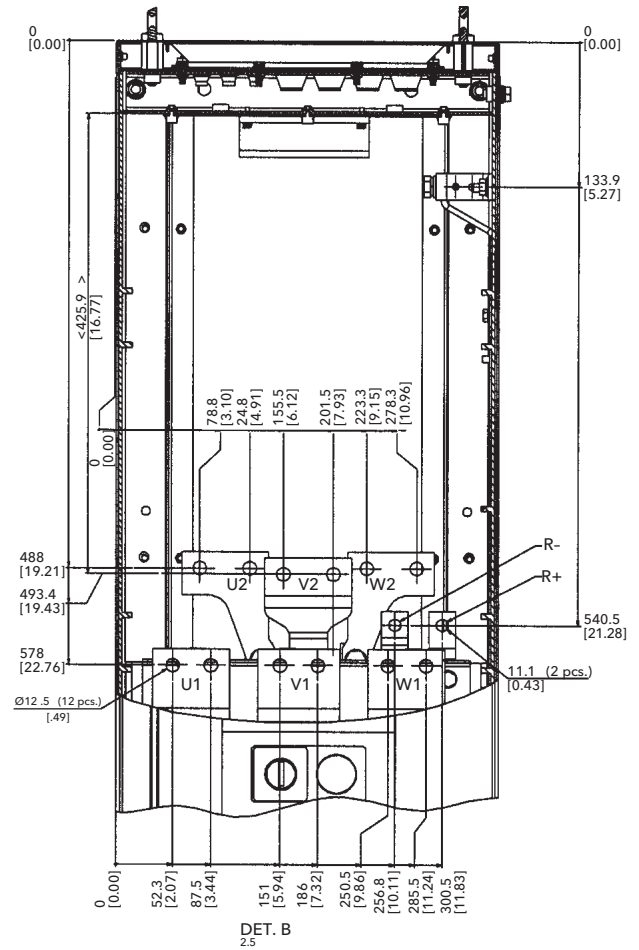
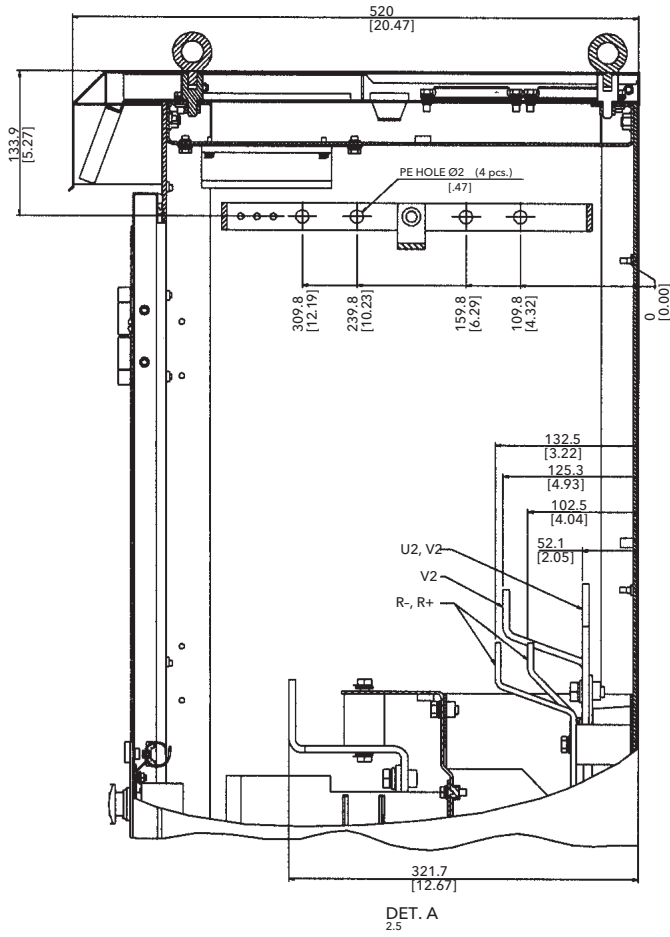

# INSTALLATION (Frames R7-R8)

## Extension Module R8

Dimensions are listed in millimeters and [inches].

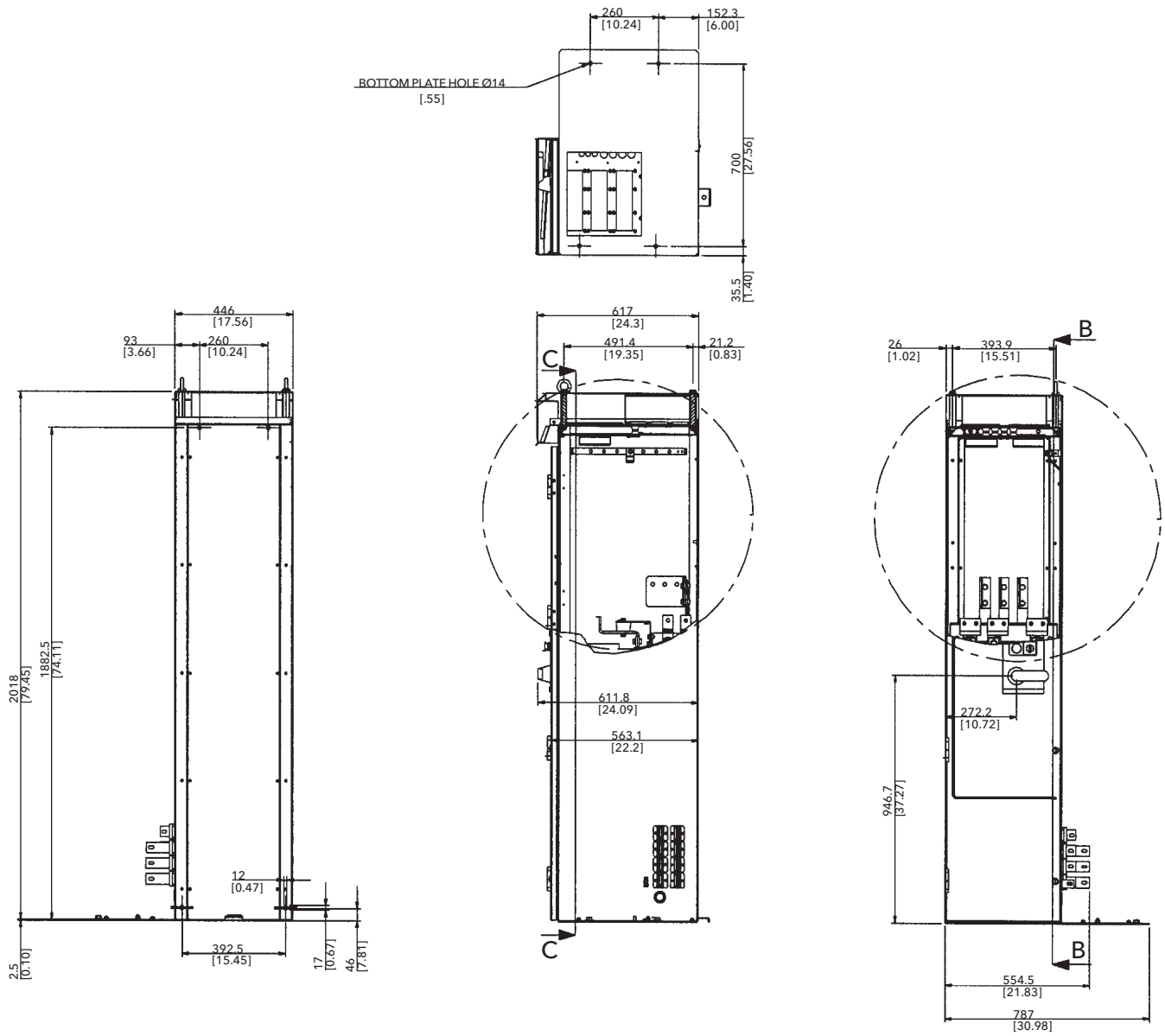

3AFE 64626388 30.04.02

# INSTALLATION (Frames R7-R8)

## Detail R8

Dimensions are listed in millimeters and [inches].

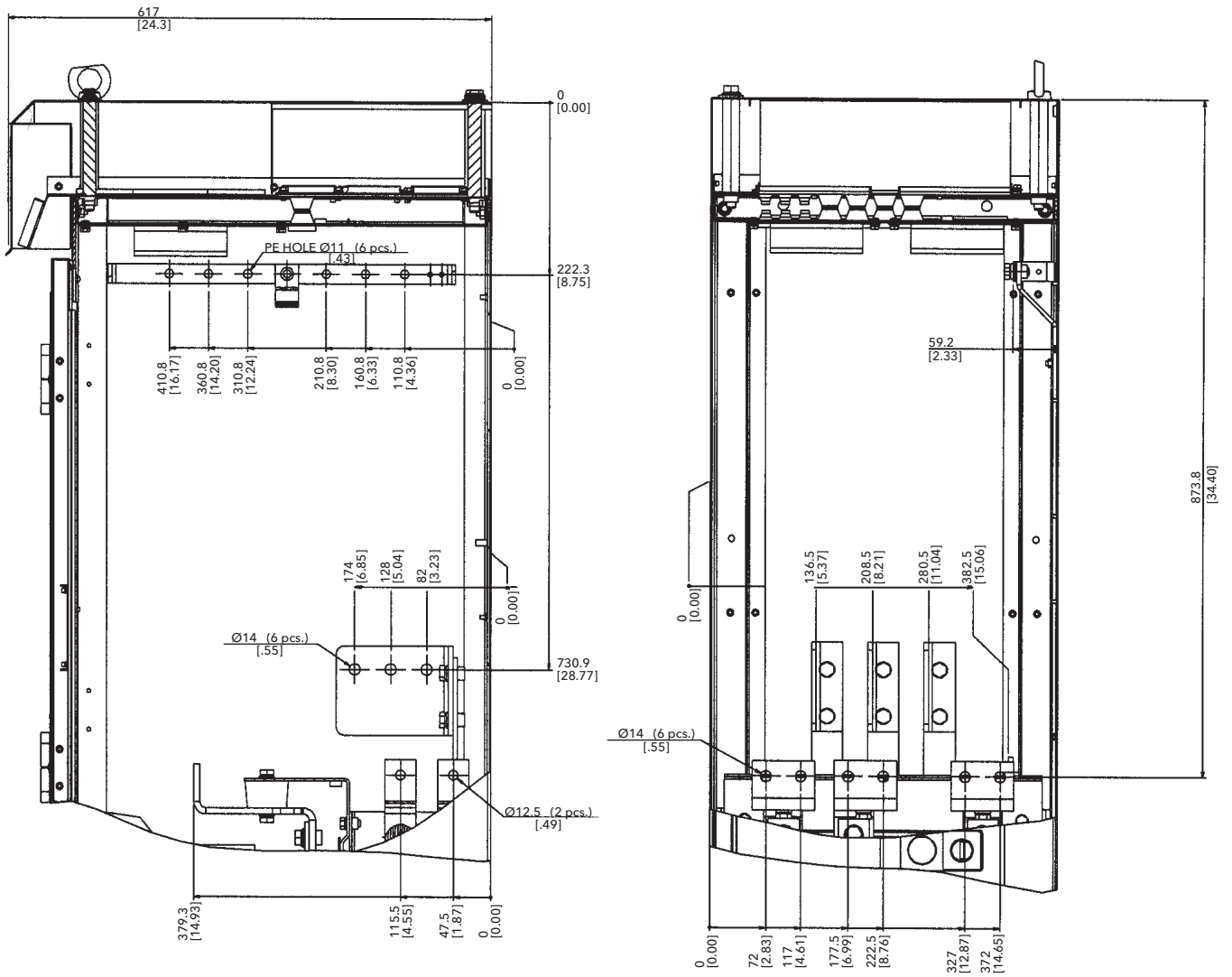

# START-UP

## Wizards

The “Wizard” configures the drive. This process sets parameters that define how the drive operates and communicates. Depending on the control and communication requirements, the start-up process may require any or all of the following:

- The Start-up Wizard steps you through the default configuration. The Start-up Wizard can be activated at the first power up, or can be accessed at any time using the main menu.
- Application macros can be selected to define common, alternate system configurations, using the default settings. See “Single or Multipump Setup/Programming” on page 73.
- Additional refinements can be made using the control panel to manually select and set individual parameters. See “Complete Parameter Descriptions” on page 50.

## Assistant Control Panel (Display)

### Features

The AQUAVAR CPC Control Panel features:

- Alphanumeric control panel with a LCD display
- Language selection for the display
- Drive connection that can be made or detached at any time
- Start-Up Wizard to ease drive commissioning
- Copy function - Parameters can be copied to the Control Panel memory for later transfer to other drives or for backup of a particular system.
- Context sensitive help

## Control Panel (Keypad)

The following table summarizes the button functions and displays on the Control Panel.

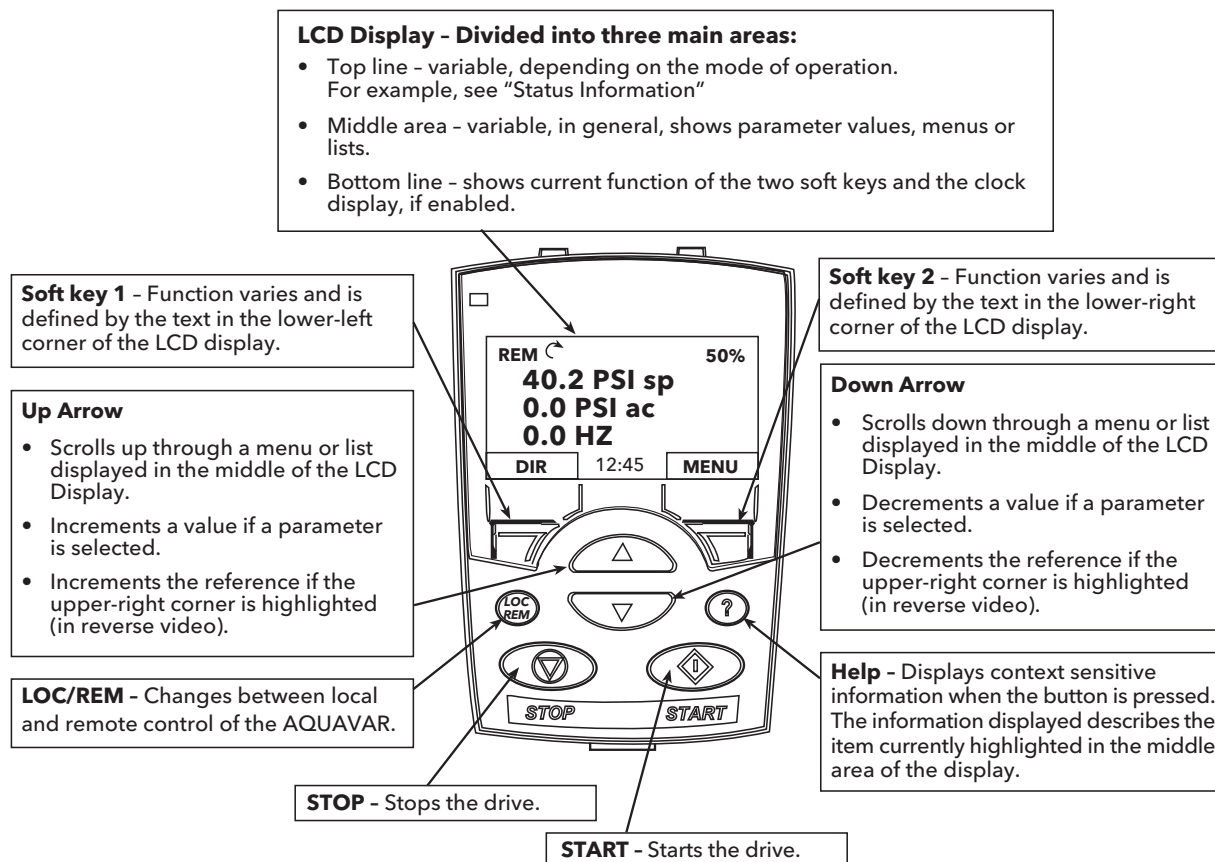



# START-UP

## Output mode

Use the output mode to read information on the drive's status and to operate the drive. To reach the Output Mode, press EXIT until the LCD display shows status information as described below.

### Status Information

**Top** - The top line of the LCD display shows the basic status information of the drive.

- **LOC** - indicates that the drive control is local, that is, from the control panel.
- **REM** - indicates that the drive control is remote, which is required to operate the pump and automatically control pressure. This mode is also used for fieldbus control. (e.g. Transducer or PLC control)
- ↻ - indicates the drive status as follows:

Control Panel Display	Significance
Rotating arrow blinking	Drive is running
Stationary arrow	Drive is stopped

- **Upper right (50%)** - shows the percentage of full scale the transducer is operating.

**Middle** - The middle of the LCD display will display:

- **For Single Pump**
  - Reference or set point. "Pressure SP"
  - Actual set point. "Pressure AC"
  - Frequency in HZ.

REM ↻	50%	
40.2 PSI sp		
0.0 PSI ac		
0.0 HZ		
DIR	12:45	MENU

**NOTE!** The AQUAVAR display will show (SET PRESSURE), (ACTUAL PRESSURE) and Frequency (Hz), in single pump mode.

**Bottom** - The bottom of the LCD display shows:

- **Lower corners** - show the functions currently assigned to the two soft keys.
- **Lower middle (12:45)** - displays the current time (if configured to show the time).

### Operating the Drive

**LOC/REM** - The very first time the drive is powered up, it is in the remote control (REM) mode, and is controlled from the Transducer and Control Panel.

To switch to local control (LOC) and control the drive using the Control Panel, press and hold the  button. The drive must be stopped!

- The Remote (REM) Mode uses the transducer and set point to control the speed output to the pump.
- The Local (LOC) Mode uses the control panel for manual control of the drive output. Speed up or down.

To switch back to remote control (REM) press and hold the  button until REMOTE CONTROL is displayed.

**Start/Stop** - To start and stop the drive press the START or STOP buttons.

# START-UP

## Other Modes

Besides the Output Mode, the Control Panel has:

- Other operating modes that are available through the main menu.
- A fault mode that is triggered by faults. The fault mode includes a diagnostic assistant mode.

### Access to Main Menu Modes

To reach the main menu:

1. Press EXIT, as necessary, to step back through the menus or lists associated with a particular mode. Continue until you are back to the Output Mode.
2. Press MENU from the Output Mode. At this point, the middle of the display is a listing of the other modes, and the top-right text says "Main Menu".
3. Press UP/DOWN to scroll to the desired mode.
4. Press ENTER to enter the mode that is highlighted. The following sections describe each of the other modes.



## Parameters Mode

Use the Parameters Mode to view and edit parameter values:

1. Select PARAMETERS in the main menu.
2. Press UP/DOWN to highlight the appropriate parameter group, then press SEL.
3. Press UP/DOWN to highlight the appropriate parameter in a group.

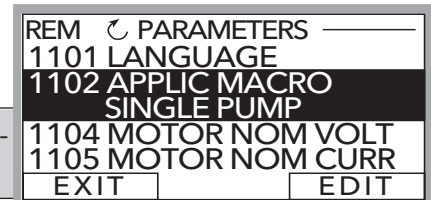
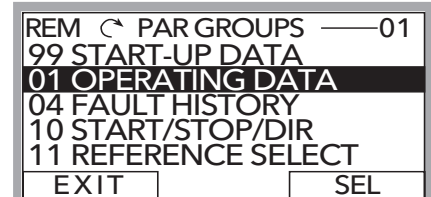

**NOTE!** The current parameter value appears below the highlighted parameter.

4. Press EDIT.
5. Press UP/DOWN to step to the desired parameter value.

**NOTE!** To view the parameter default value: In the set mode, press UP/DOWN simultaneously.

- Press SAVE to store the modified value or press CANCEL to leave the set mode. Any modifications not saved are cancelled.
- Press EXIT to return to the listing of parameter groups and again to return to the main menu.

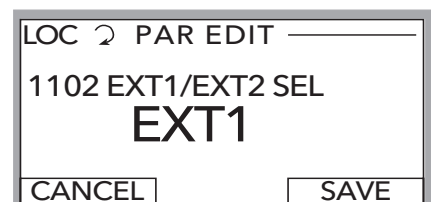

# START-UP

## Wizard Mode

When the drive is first powered up, the Start-Up Wizard guides you through the setup of a few basic parameters. For example, at the first start, the drive automatically suggests entering the first task, password.

The Start-Up Wizard is divided into tasks. You may activate the tasks one after the other, as the Start-Up Wizard suggests, or independently. (You are not required to use the assistant, you may use instead, the parameter mode to set the drive parameters.)

The order of the tasks presented by the Start-Up Wizard depends on your entries. The task list in the following table (*next page*) is typical.

## Start-Up Wizard

The start-up wizard is a tool that can be used to quickly program an Aquavar with the most commonly used single / multi-pump parameters. The wizard will prompt the programmer to enter the required parameters by automatically bringing them to the screen. To enable the wizard following the steps below:

1. In the main screen select MENU. Then press enter.
2. Press the up / down arrow to select WIZARDS, then press SELECT.
3. Enter the values for the parameters as seen in the table below, and follow each entry by pressing the SAVE key.
4. When complete, press the EXIT key until the main screen is displayed again.
5. Set the required system pressure using the up and down arrows, then start the pump using the green START key.

Task Name	Description
10.02 Pass Code	Pass word setting to open the parameter lock.
10.01 Parameter Lock	Enables or disables the parameters from being changed.
11.01 Language	Selects the display language.
11.04 Motor Nom Voltage	Defines the motor nameplate voltage.
11.05 Motor Nom Current	Defines the motor nameplate current.
11.06 Motor Frequency	Defines the motor nameplate frequency.
11.08 Nominal Motor Power	Defines the motor nominal power.
15.06 Sensor Min	Adjusts the transducer to a zero reference point.

## Changed Parameters Mode

Use the Changed Parameters Mode to view (and edit) a listing of all parameters that have been changed from default values.

### Procedure:

1. Select CHANGED PAR in the Main Menu. The display lists all changed parameters.
2. Press ENTER.
3. Press UP/DOWN to select a changed parameter. As each parameter is highlighted, the parameter value appears.
4. Press EDIT to edit the parameter value.

# START-UP

5. Press UP/DOWN to select a new value / edit the parameter value. (Pressing both keys at the same time sets a parameter to its default value.)
6. Press SAVE to save the new parameter value. (If the new value is the default value, the parameter will no longer appear on the Changed Parameters listing.)

## Par Backup Mode

The Control Panel can store a full set of drive parameters. If two sets of parameters are defined, both are copied and transferred when using this feature.

The Par Backup Mode has three functions:

- **Upload to Panel** - Copies all parameters from the drive to the Control Panel. The Control Panel memory is nonvolatile and does not depend on the panel's battery.
- **Restore All (Download To Drive All)** - Restores the full parameter set(s) from the Control Panel to the drive. Use this option to restore a drive or to configure identical drives. **Drive must be in local mode.**

**NOTE!** The Restore All function writes all parameters to the drive, including motor parameters. Only use this function to restore a drive or to transfer parameters to systems that are identical to the original system.

- **Download Application** - Copies partial parameter set(s) from the Control Panel to a drive. The partial set does not include internal motor parameters. Use this option to transfer parameters to systems that use similar configurations - the drive and motor sizes do not need to be the same.
  1. Select COPY in the Main Menu.
  2. Press UP/DOWN to step to the desired option.
  3. Press SAVE. The parameter set is transferred as directed. During the transfer, the display shows the transfer status as a percent of completion.
  4. Press EXIT to step back to the Output Mode.

## Clock Set Mode

Use the Clock Set Mode to:

- Enable/disable the clock function.
  - Set date and time.
  - Select display format.
1. Select CLOCK SET in the Main Menu.
  2. Press UP/DOWN to step to the desired option.
  3. Press EDIT.
  4. Press UP/DOWN to select the desired setting.
  5. Press SAVE to save setting.

# PARAMETER LISTINGS

## Aquavar CPC Parameter List

The Aquavar CPC parameter list contains all of the necessary pump, drive, fault and control parameters needed for programming this unit. Each group indicates a certain function and control for the Aquavar, in order to set up single or multipump control.

To view the available parameter list, on your keypad, press the MENU button to access the parameter list. The parameters are write protected with a password. Please contact your Aquavar representative for more information on this password (located in GROUP 10 LOCKS/PASSWORDS).

**Group 01, VFD SIGNALS** - (READ ONLY DATA) This set of parameters sets up the drive and motor. These parameters can only be adjusted and changed when the motor has stopped. Monitoring of motor output, and various analog and digital outputs.

**Group 02, PUMP SIGNALS** - (Data output only) Provides output set points, energy savings and wire to water power.

**Group 03, STATUS WORDS** - Provides status of drive and alarm condition.

**Group 10, LOCKS/PASSWORDS** - Provides password and parameter save information. Keypad and set point locks.

**Group 11, START UP DATA** - Provides parameters used for initial start up information (e.g language, application, voltage, motor current, motor RPM, horsepower). Used for initial motor setup.

**Group 12, START/ STOP** - Determines method(s) of starting and stopping the Aquavar. i.e. Keypad, external switch, Modbus, manual, test run and motor jog.

**Group 13, RAMPS & WINDOWS** - Parameters used for the acceleration and deceleration of the pump. Window and Hysterisis contains modulation of algorithm (pressure control regulation).

**Group 14, SPD LIM/START LVL** - Parameters that contain speed control, max and min frequency, restart value, priming delay.

**Group 15, TRANSDUCER VAR** - Parameters used for the setup and tuning of the pressure transducer, flow meter and adjustment of transducer range.

**Group 16, REFERENCE SELECT** - Parameters that control how the set point is maintained. i.e. Modbus, keypad, analog input (transducer).

**Group 18, RELAY OUTPUTS** - Parameters that define how the Aquavar output relays are controlled and what delay time is actuated for each relay. Three total relays can be used (RO1, RO2, RO3).

# PARAMETER LISTINGS

## **Aquavar CPC Parameter List** *(continued)*

**Group 19, ANALOG OUTPUTS** - Defines the analog outputs available on the drive. Two possible analog outputs that can be used to monitor various parameters (AO1, AO2).

**Group 21, REGULATE** - Defines type of control regulation with analog input from transducer. Normal, Inverse modes. Friction loss compensation.

**Group 22, MULTIPUMP CONTROL** - Defines parameters for multi-pump control algorithm. Addresses each drive. Required group for alternating each pump.

**Group 24, FAULT FUNCTIONS** - Defines parameters for faults, pump protection and run enable mode (e.g. keypad failure, pump protect, low water, error reset).

**Group 25, AUTOMATIC RESET** - This group defines conditions for automatic reset. An automatic reset occurs after a particular fault is detected. The Aquavar holds for a delay time, then automatically restarts. You can limit the number of restarts in a specific period of time for a variety of faults (e.g. overcurrent, over/ under voltage).

**Group 26, ENERGY SAVINGS** - Defines parameters used for energy savings, and kW/hr usage.

**Group 27, CRITICAL SPEEDS** - This group defines up to three critical speeds or resonant frequencies. This mechanical resonance may occur on certain loads at certain frequencies.

**Group 30, OPTION MODULES** - Defines parameters used for fieldbus communication networks and optional fieldbus adapter.

**Group 31, FIELD BUS SETUP** - Parameters used for actual set up for the field bus communication via the RS485 terminals.

**Group 32, MODBUS SETUP** - Defines parameters used for the Modbus setup and protocol, baud rate, parity, status functions.

**Group 50, MOTOR CONTROL** - Provides adjustment of the switching frequency for the drive.

**Group 51, MAINTENANCE TRIGGERS** - Defines the parameters for trigger points on the cooling fan, motor revolutions, run time, used power in Megawatts. Provides actual time run on each component.

**Group 99, INFORMATION** - Provides firmware version, drive rating for the Aquavar.

# PARAMETER LISTINGS

Group 01 <sup>①</sup>	VFD Signals	Range	Description	Defaults				
				Single Pump	Synch- ronous	Multi- Control	Constant Slave	Speed Control
0101	Motor Frequency	0.0...500.0 Hz	Calculated VFD output frequency, Hz					
0102	Motor Current	0...2.0*I <sub>2hd</sub>	Measured Motor Current, A					
0103	Motor Power	-2...2*P <sub>hd</sub>	Motor Power, kW					
0104	DC Bus Voltage	0...2.5*V <sub>dn</sub>	Measured intermediate circuit voltage, V					
0105	Motor Voltage	0...2.0*V <sub>dn</sub>	Calculated motor voltage, V					
0106	Drive Temp	0...150° C	VFD Temp, Deg C					
0107	VFD On Time	0...9999h	Elapsed time counter; runs when the drive is powered, Hrs (since last reset). Re-settable by parameter 2605.					
0108	Run Time	0...9999h	Motor run time counter, Hrs (since last reset). The counter runs when the inverter modulates. Re-settable by parameter 2605.					
0109	KWh Counter	0...9999kWh	kWh counter, kWh (since last reset). Re-settable by parameter 2605.					
0110	DI6-1 Status	000000... 111111	Status of digital inputs. Example: 0000001=DI1 is on, DI2-DI6 off					
0111	AI1	0...100 %	Value of analog input 1, %					
0112	AI2 Trnsdcr Fdbk	0...100 %	Value of analog input 2, %					
0113	RO3-1 Status	000...111	Status of relay outputs. Example: 001=RO1 is energized, RO2 & RO3 are de-energized.					
0114	AO1[mA]	0...20 mA	Value of analog output 1, mA					
0115	AO2[mA]	0...20 mA	Value of analog output 2, mA					
0116	Last Fault	Fault Codes	Last fault code of the drive.					
0117	Previous Fault 1	Fault Codes	Previous fault code of the drive.					
0118	Previous Fault 2	Fault Codes	Oldest fault code of the drive.					
0119	Fault Time 1							
0120	Fault Time 2							
0121	Speed at Flt	- RPM	Speed at the time of the latest fault.					
0122	Freq at Flt	- Hz	Frequency at the time of the latest fault.					
0123	Voltage at Flt	- V	DC bus voltage at the time of the latest fault.					

① **NOTE:** Group 01 is read-only. Used for monitoring.

# PARAMETER LISTINGS

				Defaults				
Group 01	VFD Signals	Range	Description	Single Pump	Synch-ronous	Multi-Control	Constant Slave	Speed Control
0124	Current at Flt	- A	Motor current at the time of the latest fault.					
0125	Status at Flt	-	The drive status word at the time of the latest fault.					
0126	DI 6-1 At Fault	000...111	The drive digital input status at the time of the latest fault.					
0127	Drive On Time Hi	- Days	Drive "on - time in days.					
0128	Drive On Time Lo	- Hrs : Min : Sec	Drive "on - time in hrs/min/secs.					
Group 02	Pump Signals	Range	Description	Single Pump	Synch-ronous	Multi-Control	Constant Slave	Speed Control
0201	Set Point	0...max scale	Controller set point; unit determined by parameter 1501.					
0202	Actual	0...max scale	Actual feedback; unit determined by parameter 1501.					
0203	Pump Speed	0 - 60 Hz	Actual frequency of motor, Hz.					
0204	Wire to Water Power	0...? Hp	Overall hp includes pump, motor and VFD.					
0205	Set Point #1	0...max scale	Set Point (reference) #1; unit determined by parameter 1501.					
0206	Set Point #2	0...max scale	Set Point (reference) #2; unit determined by parameter 1501.					
0207	Energy Savings	0...65353 USD	Calculated AV savings (option 1 or 2) since last reset. Savings are compared to conventional system (\$). Re-settable by parameter 26.05.					
0208	Pump Number	Stopped, Pump 1...Pump 4	Actual pump number in multi-pump control mode.					
0209	Used Set Point	0...max scale	Same value as in 0205 or 0206, depending on which is in use.					
Group 03	Status Words	Range	Description	Single Pump	Synch-ronous	Multi-Control	Constant Slave	Speed Control
0301	FB CMD Word 1	–	Low word of drive's control word					
0302	FB CMD Word 2	–	High word of drive's control word					
0303	FB STS Word 1	–	Low word of drive's status word					
0304	FB STS Word 2	–	High word of drive's status word					
0305	Fault Word 1	–	Fault word 1 of the drive					
0306	Fault Word 2	–	Fault word 2 of the drive					
0307	Fault Word 3	–	Fault word 3 of the drive					
0308	Alarm Word 1	–	Alarm word 1 of the drive					
0309	Alarm Word 2	–	Alarm word 2 of the drive					



# PARAMETER LISTINGS

				Defaults				
Group 03	Status Words	Range	Description	Single Pump	Synchronous	Multi-Control	Constant Slave	Speed Control
0310	AV Alarm Word	–	Aquavar Alarm word					
0311	AV Fault Word	–	Aquavar Fault word					
0312	Comm RO Word	–						
0313	Comm Value 1	–						
0314	Comm Value 2	–						
Group 10	Locks/ Passwords	Range	Description	Single Pump	Synchronous	Multi-Control	Constant Slave	Speed Control
1001	Parameter Lock		Selects the state of the parameter lock. The lock prevents parameters from being changed.	Locked	Locked	Locked	Locked	Locked
		Open	The lock is open. Parameter values can be changed.					
		Locked (Default)	Parameter values cannot be changed from the keypad. The lock can be opened by entering the valid password in parameter 10.02. When the keypad is locked the AV keypad functionality is limited to starting, stopping and changing the reference (set point).					
1002	Pass Code	0...300000	Password setting <b>66</b> opens the lock and returns the value to zero on the display. The password relocks when power is disconnected. To relock the keypad reset parameter 1001 to "Locked".	0	0	0	0	0
1003	Local Lock		Disables local control on the keypad. <b>WARNING!</b> Before activating, ensure that the control panel is not needed for stopping the drive.	Off	Off	Off	Off	Off
		Off (Default)	Local control allowed.					
		On	Local control disabled.					
1004	Parameter Save		Saves the parameter values to the permanent memory.	Done	Done	Done	Done	Done
		Done (Default)	Parameters entered via the keypad are automatically saved. Parameters are not automatically saved when altered through the fieldbus connection.					

# PARAMETER LISTINGS

Group 10	Locks/ Passwords	Range	Description	Defaults				
				Single Pump	Synch-ronous	Multi-Control	Constant Slave	Speed Control
1004	Parameter Save (continued)	Save	Used for manually saving parameters that have been altered through the fieldbus connection.	Done	Done	Done	Done	Done
1005	New Pass Code	0...300000	Sets new pass code for parameter lock. Returns to 0 after saving.	0	0	0	0	0
1006	Set Point Lock		Disables set point changes from the keypad.	Off	Off	Off	Off	Off
		Off (Default)	Local control allowed.					
		On	Local control allowed.					
Group 11	Start-Up Data	Range	Description	Single Pump	Synch-ronous	Multi-Control	Constant Slave	Speed Control
1101	Language		Selects the display language	English	English	English	English	English
		English (AM) (Default)	American English.					
		Español	Spanish (full translation)					
		Francais	French (full translation)					
1102	Application Macro		Selects the application macro	✓	✓	✓	✓	✓
		Single Pump (Default)	One AV regulating to a set point					
		Synchronous	Lag pumps start as needed and all pumps regulate to the set point at the same speed. Note: it is recommended that all pumps be identical.					
		Multicontrol	Lag pumps start as needed. The last lag pump to start regulates to the set point; the remaining pumps operate at an enable sequence speed (2203).					
		Constant Slave	The master unit starts up to three fixed speed slave units when needed. See RO1, RO2 and RO3 settings (parameters 1801, 1804 and 1807).					
		Speed Control	AV follows a speed reference only. Pump protect fault function is inactive.					
1103	Application Restore	No	Resets parameters to default settings.					
		Yes						

# PARAMETER LISTINGS

				Defaults				
Group 11	Start-Up Data	Range	Description	Single Pump	Synch-ronous	Multi-Control	Constant Slave	Speed Control
1104	Motor Nom Voltage	11...345V/ 230...690V	Defines the motor voltage. Equal to the value on the motor nameplate.	230/ 460/ 575	230/ 460/ 575	230/ 460/ 575	230/ 460/ 575	230/ 460/ 575
1105	Motor Nom Current	0.2*I <sub>2hd</sub> ... 2.0*I <sub>2hd</sub>	Defines the motor current. Equal to the value on the motor nameplate.	1.0* I <sub>2hd</sub>	1.0* I <sub>2hd</sub>	1.0* I <sub>2hd</sub>	1.0* I <sub>2hd</sub>	1.0* I <sub>2hd</sub>
1106	Motor Nom Freq	10.0...500Hz	Defines the motor nominal frequency. Equal to the value on the motor nameplate.	60	60	60	60	60
1107	Motor Nom RPM	50...18000 RPM	Defines the motor nominal speed. Equal to the value on the motor nameplate.	3550	3550	3550	3550	3550
1108	Motor Nominal Power	0.2...2.0*P <sub>hd</sub>	Defines the motor power (hp). Equal to the value on the nameplate.	1.0*P <sub>hd</sub>	1.0*P <sub>hd</sub>	1.0*P <sub>hd</sub>	1.0*P <sub>hd</sub>	1.0*P <sub>hd</sub>
Group 12	Start/Stop	Range	Description	Single Pump	Synch-ronous	Multi-Control	Constant Slave	Speed Control
1201	Start/Stop		Defines the connections and source of the start/stop commands. <i>Comment - DI1=Enable. 0= Disable, 1= Enable. DI2= Low Water. 0= Fault, 1= OK, DI3= Estop 0= Estop, 1= OK, After Estop restart from keypad required.</i>	Keypad	Keypad	Keypad	Keypad	Keypad
		Keypad	Start/Stop from keypad. After a fault reset, the drive will restart only if auto restart (1202) is set to on. If auto restart is off the drive must be started from the keypad.					
		Fieldbus	Start via fieldbus control word					
1202	Auto Restart		Selects whether the AV will automatically restart after a power failure or fault reset.	On	On	On	On	On
		Off	Not selected					
		On	Selected. The AV will automatically restart if conditions permit.					
1203	Test Run		Selects when the drive will perform a test run	Not Sel	Not Sel	Not Sel	Not Sel	Not Sel
		Not Sel (default)	Not selected					

# PARAMETER LISTINGS

Group 12	Start/Stop	Range	Description	Defaults				
				Single Pump	Synch-ronous	Multi-Control	Constant Slave	Speed Control
1203	Test Run (continued)	Automatic	If selected and the drive has not run for the test delay (1205) the drive will start and run at 50% of maximum speed (1401) for 20 seconds and shutdown. Auto Restart 1202 must be on.					
		Manual	Once manual is selected the drive will start and run at test speed (1204) for 20 seconds and shutdown. Once the manual test is complete this parameter will return to "Not Sel".	Not Sel	Not Sel	Not Sel	Not Sel	Not Sel
1204	Test Speed % (FL)	0...100%	Selects the speed the test runs at in manual test mode (1203).	25%	25%	25%	25%	25%
1205	Test Run Delay	0...3600 Hr	Selects how long after the drive is idle before it will do a test run.	1000	1000	1000	1000	1000
1206	Motor Jog		Jogs motor for 10 sec @ 60 RPM to check for motor rotation.	Disabled	Disabled	Disabled	Disabled	Disabled
1209	Manual Override	Disabled (Default)	Drive will run at constant speed as set in Parameter 1210 when enabled and contact DI5 is active.					
1210	Override Freq	0-60 Hz	Sets motor speed when manual override is active.					
Group 13	Ramps/Windows	Range	Description	Single Pump	Synch-ronous	Multi-Control	Constant Slave	Speed Control
1301	Ramp 1 Fast Accel	0...1800 sec	Defines the fast acceleration time.	5	5	5	5	5
1302	Ramp 2 Fast Decel	0...1800 sec	Defines the fast deceleration time.	5	5	5	5	5
1303	Ramp 3 Slow Accel	0...1800 sec	Defines the slow acceleration time.	60	60	60	60	60
1304	Ramp 4 Slow Decel	0...1800 sec	Defines the slow deceleration time.	60	60	60	60	60
1305	Ramp Hysteresis	0...100 %	Per cent of window set aside for hysteresis error.	80	80	80	80	80
1306	Reg Window	0...100 %	Window around the set point which the control algorithm operates.	8	8	8	8	8
Group 14	Spd Lim/Strt Lvl	Range	Description	Single Pump	Synch-ronous	Multi-Control	Constant Slave	Speed Control
1401	Maximum Frequency/Speed	Minimum Frequency... 60 Hz	Defines the allowable maximum speed. Default setting is parameter 1106 Motor Nom Freq. (May want to show RPM or HZ.)	60	60	60	60	60

# PARAMETER LISTINGS

Group 14	Spd Lim/ Strt/Lvl	Range	Description	Defaults				
				Single Pump	Synch-ronous	Multi-Control	Constant Slave	Speed Control
1402	Minimum Frequency/Speed	0...Max Frequency	Defines the minimum speed range. Default setting is 10% of parameter 1106 Motor Nom Freq. (May want to show RPM or HZ.)	6	6	6	6	6
1403	Config Speed Min		Defines the reaction of the drive when the AV tries to regulate at a speed at or below minimum frequency (1402).	0	0	0	0	0
		0 (Default)	The drive will stay at Minimum Frequency until Stp Delay Min Spd (1404) times out; the unit will then shutdown.					
		Min Freq	The AV will stay at this speed until the transient clears or unit is manually shutdown; unless a fault occurs.					
1404	Stp Delay Min Spd	0...1800 s	The time period the drive will stay at MinSpd (1402) before stopping. Functions when 1403 is set to 0. Becomes active if set point would result in regulation below min spd, closed valve condition in pressure control and Secondary Protect A&B.	0	0	0	0	0
1405	Restart Value	0...150 %	If the drive is shutdown by Config speed min (1403) due to no system demand (pressure control and level control only) the drive will sleep until the process actual value drops below a set restart value (1405) for longer than the restart delay (1406). If operating in inverse mode (2101) the drive will sleep until the process variable rises above the restart value. Wake-up level in % of set point value. To disable the Restart Value function in both normal and inverse settings enter "0%". Auto Restart (parameter 1202) does not influence the restart function. Default = 0.	0	0	0	0	0
1406	Restart Delay	0...1800 s	Time delay for restart value (1405),(Default = 0 sec)	0	0	0	0	0

# PARAMETER LISTINGS

Group 14	Spd Lim/ Strt/Lvl	Range	Description	Defaults				
				Single Pump	Synch-ronous	Multi-Control	Constant Slave	Speed Control
1407	Priming Delay	0...6000 s	When the drive is starting from 0 RPM this parameter delays pump protection faults (2404 and 2407) for the setting time. The default setting is "0". Once the priming delay time is complete the protection delay (parameter 2406) becomes functional. During the priming delay the pump runs at the maximum speed setting (parameter 1401) since it cannot achieve the set point.	0	0	0	0	0
Group 15	Transducer Var	Range	Description	Single Pump	Synch-ronous	Multi-Control	Constant Slave	Speed Control
1501	Transducer Unit		Selects the units (default is pressure) for the primary process transmitter feedback located at AI2. In speed control macro default unit is RPM.	Psig	Psig	Psig	Psig	Psig
		%						
		GPM						
		Psig (Default)						
		Ft						
		F Deg						
C Deg								
1502	Transducer Max	0...6553.5	For single pump and multipump macros this parameter defines the full-scale feedback (20 mA setting) of the primary process transmitter at AI2. This parameter also correlates to the maximum value of Reference (set points) 1 and 2. For the Speed Control macro this parameter scales the maximum (20 mA or keypad ) speed setting. Note when units are in Ft, M, In or Cm: AI2 Max is always based on a specific gravity = 1 regardless of setting for parameter 1506. Actual pressure signals in Ft, M, In or Cm are corrected for specific gravity by the firmware. Signal can be quadratic or linear.	300	300	300	300	60

# PARAMETER LISTINGS

Group 15	Transducer Var	Range	Description	Defaults				
				Single Pump	Synch-ronous	Multi-Control	Constant Slave	Speed Control
1503	Transducer Min	0...6553.5	For single pump and multipump macros this parameter defines the value (normally zero) of the 4 mA setting for the primary process transmitter at AI2. This parameter also correlates to the minimum value of Reference (set points) 1 and 2. For the Speed Control macro this parameter scales the value (normally zero) of the 4 mA or keypad speed setting. Note when units are in Ft, M, In or Cm: AI2 Min is always based on a specific gravity = 1 regardless of setting for parameter 1506. Actual pressure signals in Ft, M, In or Cm are corrected for specific gravity by the firmware. Signal can be quadratic or linear.	0	0	0	0	0
1506	Sensor Min <i>(Not in Software)</i>		Defines the value for analog sensor input.	4 mA	4 mA	4 mA	4 mA	4 mA
		4 mA (Default)	4 mA is selected as the minimum value.					
		Tuned Value	Select tuned value after the tune function has been completed. This will select the tuned value for the minimum value of sensor input.					
		Tune	This parameter sets the minimum value of the signal to be applied to sensor input. When tune is selected and enter is pressed the tuned value for sensor input is set to the actual sensor input value when the tune function was activated. This function is useful for zeroing out any system hysteresis.					

# PARAMETER LISTINGS

Group 16	Reference Select	Range	Description	Defaults				
				Single Pump	Synchronous	Multi-Control	Constant Slave	Speed Control
1601	SP1/SP2 Select		Defines the source from which the drive reads the signal that selects the setpoint.	Ref 1	Ref 1	Ref 1	Ref 1	Ref 1
		Reference 1 (Default)	Reference 1 (set point 1) is being used only.					
		DI4	Digital Input 4 selects set point 1 or set point 2. Open = Set Point 1, Closed = Set Point 2.					
		Fieldbus	The set point is sent via Fieldbus control word.					
1602	Set Point 1 Select		Selects the signal source for Reference1 (set point #1).	Keypad	Keypad	Keypad	Keypad	Keypad
		Keypad (Default)	The set point is selected from the keypad.					
		Analog Input Speed Control	The set point is selected by an analog input (AI1).					
		Fieldbus	The set point is selected via Fieldbus control word.					
1603	Set Point 2 Select		Selects the signal source for Reference1 (set point #2).	Keypad	Keypad	Keypad	Keypad	Keypad
		Keypad (Default)	The set point is selected from the keypad.					
		AI 1	The set point is selected by an analog input (AI1).					
		Fieldbus	The set point is selected via Fieldbus control word.					
1604	AI 1 Minimum		Defines the minimum value for analog input AI1.	4-20 mA	4-20 mA	4-20 mA	4-20 mA	4-20 mA
		0-10 VDC	A 0VDC signal will activate a Sensor Failure fault function unless 24.01 and 24.02 are disabled.					
		4 - 20 mA (Default)	4 mA is selected as the minimum value.					
		Tuned Value	Select tuned value after the tune function has been completed. This will select the tuned value for the minimum value of AI1.					



# PARAMETER LISTINGS

Group 16	Reference Select	Range	Description	Defaults				
				Single Pump	Synch-ronous	Multi-Control	Constant Slave	Speed Control
1604	AI 1 Minimum <i>(continued)</i>	Tune	This parameter sets the minimum value of the signal to be applied to AI1. When tune is selected and enter is pressed the tuned value for AI1 is set to the actual AI1 value when the tune function was activated. This function is useful for zeroing out any system hysteresis.	4-20 mA	4-20 mA	4-20 mA	4-20 mA	4-20 mA
Group 18	Relay Outputs	Range	Description	Single Pump	Synch-ronous	Multi-Control	Constant Slave	Speed Control
1801	Relay RO1 Output		Selects the AV status to be indicated through relay output 1 (RO1). The relay energizes when the status meets the setting. Relay warnings are reset automatically, faults must be manually reset.	Ready	Ready	Ready	Start Slave	Ready
		Not Sel	The output is not used					
		Run	The output indicates the drive is running.					
		Ready (Default)	The output indicates that power is supplied to the drive and it is awaiting a start command.					
		VFD Fault	The drive has faulted					
		Low Water	The secondary protection warning or fault function has been activated. DI4 is low for the protection delay setting (2404). Closed = normal, Open = Secondary Protect fault function is active.					
		Pump Protect	The pump protection warning or fault function has been activated.					
		Start Slave	Used in multipump macro to start slave pump only.					
	Stand by	Drive is in sleep mode due to no system demand.						
1802	RO1 ON Delay	0...3600 s	Defines the operation delay for relay output RO1.	0	0	0	0	0
1803	RO1 OFF Delay	0...3600 s	Defines the release delay for relay output RO1.	0	0	0	0	0

# PARAMETER LISTINGS

Group 18	Relay Outputs	Range	Description	Defaults				
				Single Pump	Synchronous	Multi-Control	Constant Slave	Speed Control
1804	Relay RO2 Output		Selects the AV status to be indicated through relay output 2 (RO2). The relay energizes when the status meets the setting. Relay warnings are reset automatically, faults must be manually reset.	Running	Running	Running	Start Slave	Running
		Not Sel	The output is not used					
		Run (Default)	The output indicates the drive is running.					
		VFD Fault	The drive has faulted					
		Low Water	The secondary protection warning or fault function has been activated. D14 is low for the protection delay setting (2404). Closed = normal, Open = Secondary Protect fault function is active.					
		Pump Protect	The pump protection warning or fault function has been activated.					
		Start Slave	Used in multipump macro to start slave pump only.					
		Stand by	Drive is in sleep mode due to no system demand.					
1805	RO2 ON Delay	0...3600 s	Defines the operation delay for relay output RO2.	0	0	0	0	0
1806	RO2 OFF Delay	0...3600 s	Defines the release delay for relay output RO2.	0	0	0	0	0
1807	Relay RO3 Output		Selects the AV status to be indicated through relay output 3 (RO3). The relay energizes when the status meets the setting. Relay warnings are reset automatically, faults must be manually reset.	Not Used	Not Used	Not Used	Not Used	Not Used
		Not Sel (default)	The output is not used					
		Run	The output indicates the drive is running.					
		Ready	The output indicates that power is supplied to the drive and it is awaiting a start command.					
		VFD Fault	The drive has faulted					

# PARAMETER LISTINGS

				Defaults				
Group 18	Relay Outputs	Range	Description	Single Pump	Synch-ronous	Multi-Control	Constant Slave	Speed Control
		Low Water	The secondary protection warning or fault function has been activated. DI4 is low for the protection delay setting (2404). Closed = normal, Open = Secondary Protect fault function is active.					
		Pump Protect	The pump protection warning or fault function has been activated.					
		Start Slave	Used in multipump macro to start slave pump only.					
		Stand by	Drive is in sleep mode due to no system demand.					
1808	RO3 ON Delay	0...3600 s	Defines the operation delay for relay output RO3.	0	0	0	0	0
1809	RO3 OFF Delay	0... 3600 s	Defines the release delay for relay output RO3.	0	0	0	0	0
Group 19	Analog Outputs	Range	Description	Single Pump	Synch-ronous	Multi-Control	Constant Slave	Speed Control
1901	AO 1 Content Sel		Connects a AV signal to analog output 1 (AO1).	Not Used	Not Used	Not Used	Not Used	Not Used
		Not Sel (default)	Not in use.					
		Frequency	Output frequency. 20 mA = motor nominal frequency (1106).					
		Current	Output current. 20 mA = motor nominal current (1105).					
		Torque	Motor torque. 20 mA = 100% of motor nominal rating.					
		Power	Motor Power. 20 mA = 100% of motor power rating.					
		Proc Var/ Actual	Actual value of process variable AI2. 20 mA = Reference 1 Max (1603).					
		Energy Saving	Calculated energy savings (option 1 or 2) over a conventional fixed speed system. 20 mA = Savings scale (2603).					
1902	AO1 Content Min	Various	Selects the minimum value of the characteristic being monitored.					
1903	AO1 Content Max	Various	Selects the maximum value of the characteristic being monitored.	4	4	4	4	4

# PARAMETER LISTINGS

Group 19	Analog Outputs	Range	Description	Defaults				
				Single Pump	Synch-ronous	Multi-Control	Constant Slave	Speed Control
1904	Minimum AO1	0.0...20.0 mA	Defines the minimum value of AO1. Default = 4 mA.	0.1	0.1	0.1	0.1	0.1
1905	Maximum AO1	0.0...20.0 mA	Defines the maximum value of AO1. Default = 20 mA.	20	20	20	20	20
1906	AO 2 Content Sel		Connects a AV signal to analog output 2 (AO2).	Not Used	Not Used	Not Used	Not Used	Not Used
		Not Sel (default)	Not in use.					
		Frequency	Output frequency. 20 mA = motor nominal frequency (1106).					
		Current	Output current. 20 mA = motor nominal current (1105).					
		Torque	Motor torque. 20 mA = 100% of motor nominal rating.					
		Power	Motor Power. 20 mA = 100% of motor power rating.					
		Proc Var/ Actual	Actual value of process variable AI2. 20 mA = Reference 1 Max (1603).					
		Energy Saving	Calculated energy savings (option 1 or 2) over a conventional fixed speed system. 20 mA = Savings scale (2603).					
1907	AO2 Content Min	Various	Selects the minimum value of the characterisitc being monitored.					
1908	AO2 Content Max	Various	Selects the maximum value of the characteristic being monitored.					
1909	Minimum AO2	0.0...20.0 mA	Defines the minimum value of AO2. Default = 4 mA	4	4	4	4	4
1910	Maximum AO2	0.0...20.0 mA	Defines the maximum value of AO2. Default = 20 mA	20	20	20	20	20
Group 21	Regulate	Range	Description	Single Pump	Synch-ronous	Multi-Control	Constant Slave	Speed Control
2101	Regulation Mode		Selects the type of AV control with falling process variable signal.	Normal	Normal	Normal	Normal	Normal
		Normal (Default)	Increases the output speed with falling process variable signal. For level control applications the tank is on the discharge side.					
		Inverse	Decreases the output speed with falling process variable signal. For level control applications the tank is on the suction side.					

# PARAMETER LISTINGS

				Defaults				
Group 21	Regulate	Range	Description	Single Pump	Synchronous	Multi-Control	Constant Slave	Speed Control
2102	Press Incr Speed	0...60 Hz	Sets the speed for which additional pressure is added to compensate for system frictional losses at increased flow. Used for single pump and backup modes only. Default = 20 Hz.	20	20	20	20	20
2103	Press Incr	0...10000	The pressure increase in selected units point which is added to the set point pressure to compensate for frictional losses at the pressure increase speed. Used for single pump and backup modes only. Note the full set point pressure increase (%) is achieved at maximum speed (1401).	0	0	0	0	0
Group 22	Multipump Control	Range	Description	Single Pump	Synchronous	Multi-Control	Constant Slave	Speed Control
2201	Value Decrease	0...1000	Defines how much the actual can drop before the next lag pump is started. Used for multicontrol, synchronous control and slave modes only.	5	5	5	5	5
2202	Value Increase	0...1000	Defines the increase in set point when a lag pump starts. This value is cumulative with each lag pump that turns on. Used for multicontrol, synchronous control and slave modes only. The default setting for 2202 is equal to the value set in 2201.	5	5	5	5	5
2203	Enable Sequence	0... 60 Hz	Defines the speed the drive must be at before multipump operation is allowed.. Applies to synchronous, multicontrol and slave modes only. Default = 98% of 1401 Maximum Speed.	59	59	59	59	59
2204	Switch Lead Lag	1...100 h	Defines the time the lead unit will run before a new unit is deemed the lead unit. Note if set to 1001 (Not SEL) the switching function is disabled (including switching during a fault). Default setting is 48 hrs.	48	48	48	48	48

# PARAMETER LISTINGS

				Defaults				
Group 22	Multipump Control	Range	Description	Single Pump	Synchronous	Multi-Control	Constant Slave	Speed Control
2205	Sync Limit	0...60 Hz	Selects the speed at which lag pump #1 (or slave #1 RO1) should be turned off. Applies to synchronous, multicontrol and slave modes.		45	45	45	
2206	Sync Window	0...60 Hz	The speed step above the sync limit (2206) used to turn off lag pump #2 (or slave #2 RO2). Twice the Sync Window is the speed step at which lag pump #3 (or slave #3 RO3) is turned off. Used for synchronous and slave modes only.		8	8	8	
2207	Pump Address	1...4	Defines the pump address for multipump systems.	1	1	1	1	1
2208	Setp2 Source	OFF, 1...4	Defines which pump has the analog input connected for second set point.	Off	Off	Off	Off	Off
Group 24	Fault Functions	Range	Description	Single Pump	Synchronous	Multi-Control	Constant Slave	Speed Control
2401	Keypad Failure		Selects how the AV will react to a keypad communication break.					
		Disabled	Protection is inactive					
		Fault	The drive trips on fault and the motor coasts to a stop. A fault message is generated "Panel Loss".					
2402	Pump Protect Ctrl	Fault	Actual process value is lower than protection limit (2403) for protection delay (2404) and AV is at max speed for the protection delay.	Dis-abled	Dis-abled	Dis-abled	Dis-abled	Dis-abled
		Disabled (Default)	Protection is disabled.					
		Warning	The AV generates a warning only "Pump Protect"; no other action is taken.					
		Warn and Control	The AV generates a warning "Pump Protect" and controls according to the setting of Config Speed Min (1403).					

# PARAMETER LISTINGS

Group 24	Fault Functions	Range	Description	Defaults				
				Single Pump	Synch-ronous	Multi-Control	Constant Slave	Speed Control
2403	Protection Limit	0...6553.5	This is the protection limit in PSI for the process value at which Pump Protect Ctrl (2402) activates when pump is at max speed for the protection delay.	0	0	0	0	0
2404	Protection Delay	0...200 s	This is the protection delay period prior to activation of Pump Protect Ctrl (2402). Default setting is "0 sec".	0	0	0	0	0
2405	Low Water		Loss of digital input 2 (DI2) for protection delay (2404).	Dis-abled	Dis-abled	Dis-abled	Dis-abled	Dis-abled
		Disabled (Default)	Protection is disabled.					
		Warn	The AV generates a warning only "Secondary Protect A"; no other action is taken.					
		Warn and Control	Parameter 1202 Auto Restart must be set to "On" to automatically restart once fault has been reset.					
2406	Error Reset	0...9999	Indicates number of fault resets. Note parameter 1202 Auto Restart must be set to "on". When set to "0" Error Reset is disabled. Time between resets is parameter 2407 Reset Delay. Manual intervention is required if fault is still active after set number of resets has been achieved. The drive reaction to the fault will be according to parameter 1405 Config Speed Min setting. Reset is applicable to parameters 2404 and 2405.	0	0	0	0	0
2407	Reset Delay	1...250 s	Defines the time that the AV will wait after an alarm and control condition before attempting an error reset.	60 s	60	60	60	60
2408	Run Enable		DI1 has to be closed for drive to be able to run.					
		Disable	Run Enable is not in use					
		Enable	DI1 is used for Run Enable Function.					

# PARAMETER LISTINGS

				Defaults				
Group 24	Fault Functions	Range	Description	Single Pump	Synch-ronous	Multi-Control	Constant Slave	Speed Control
2409	Comm Fault Function		Selects how the drive reacts in a fieldbus comm break i.e.; if the drive fails to receive command word or reference. The time delays is given by parameter 2410.	Last Speed	Last Speed	Last Speed	Last Speed	Last Speed
		Not Selected	No response					
		Fault	Drive Faults and coasts to stop					
		Last Speed	Drive displays a warning and remains running at last speed reference.					
2410	Comm Fault Time	0...60.0s	Defines the time delay for the control word or reference supervision.	3.0 s	3	3	3	3
Group 25	Automatic Reset	Range	Description	Single Pump	Synch-ronous	Multi-Control	Constant Slave	Speed Control
2501	NR of Trials	0...5	Sets the number of allowed automatic resets within a trial period defined by parameter 2502.	0	0	0	0	0
2502	Trial Time	1.0...600.0 s	Sets the time limit used for counting and limiting the number of resets.	30 s	30 s	30 s	30 s	30 s
2503	Delay Time	0.0...120.0 s	Sets the delay between fault detection and attempted drive restart.	0 s	0 s	0 s	0 s	0 s
2504	AR Overcurrent		Auto reset after overcurrent fault.	Enabled	Enabled	Enabled	Enabled	Enabled
		Disable						
2505	AR Overvoltage		Auto reset of overvoltage fault.	Enabled	Enabled	Enabled	Enabled	Enabled
		Disable						
2506	AR Undervoltage		Auto reset for undervoltage of drive.	Enabled	Enabled	Enabled	Enabled	Enabled
		Disable						
2507	AR AI<Min		Auto reset after transducer signal loss.	Enabled	Enabled	Enabled	Enabled	Enabled
		Disable						
Group 26	Energy Savings	Range	Description	Single Pump	Synch-ronous	Multi-Control	Constant Slave	Speed Control
2601	Energy Cost	0.000...1.000	Cost of energy in USD					
2602	Baseline Power	0...1000 hp	Baseline HP for a conventional fixed speed system.					
2603	Savings Scale	0...65535	This parameter scales the analog output when energy savings is selected.	10000	10000	10000	10000	10000
2604	Energy Save Methd			Savings Op 1	Savings Op 1	Savings Op 1	Savings Op 1	Savings Op 1
		Savings Op 1						
		Savings Op 2						



# PARAMETER LISTINGS

				Defaults				
Group 26	Energy Savings	Range	Description	Single Pump	Synchronous	Multi-Control	Constant Slave	Speed Control
2605	Energy Save Reset		Resets energy savings counter. After resetting, parameter 2605 returns to disabled.	Dis-abled	Dis-abled	Dis-abled	Dis-abled	Dis-abled
		Disabled						
		Reset						
Group 30	Option Modules	Range	Description	Single Pump	Synchronous	Multi-Control	Constant Slave	Speed Control
3001	Comm Protocol Select		Activates the optional external DCS and selects the interface. Refer to the ABB IOM chapter on fieldbus control. Can be used only with Single Pump, Constant Slave or Speed Control modes.	No	No	No	No	No
		Not Selected (Default)	No fieldbus communication.		Aquavar	Aquavar		
		Std Modbus	Drive uses Modbus protocol on the standard RS485 port. Protocol settings are in group 32.					
		Ext Fba	The drive communicates with a fieldbus adapter module in option slot 2 of the drive. Note when Ext Fba is selected Parameter Groups 31 is unlocked.					
		Aquavar	This protocol is used for communication between the drives in the Synchronous and Multicontrol macros.					
Group 31	Fieldbus Setup	Range	Description	Single Pump	Synchronous	Multi-Control	Constant Slave	Speed Control
3101	FBA Type		This parameter configures the module type automatically by the fieldbus adapter. No action is required by the user unless changes to default settings are desired. Refer to the fieldbus manual.					
3102-3133	FBA Parameters		Meaning and values of these parameters depend on the fieldbus option connected to the drive.					

# PARAMETER LISTINGS

Group 32	Modbus Setup	Range	Description	Defaults				
				Single Pump	Synchronous	Multi-Control	Constant Slave	Speed Control
3201	Protocol ID	0...0xFFFF	This parameter configures the module type automatically by the fieldbus adapter. No action is required by the user unless changes to default settings are desired. Refer to the fieldbus manual.					
3202	Station ID	0...247		1	1	1	1	1
3203	Baud Rate	1.2...57.6 kbits/s		9.6 kbits/s	9.6 kbits/s	9.6 kbits/s	9.6 kbits/s	9.6 kbits/s
3204	Parity		Defines the data length, parity and stop bits.	8N2	8N2	8N2	8N2	8N2
		8N1	8 data bits, no parity and one stop bit					
		8N2	8 data bits, no parity and two stop bits					
		8E1	8 data bits, even parity and one stop bit.					
		8O1	8 data bits, odd parity and one stop bit.					
3205	Control Profile		Selects the communication profile.	ABB Drives	ABB Drives	ABB Drives	ABB Drives	ABB Drives
		ABB Drives	ABB Drives control word and Status Word.					
		AV	Alternate Profile.					
3206	OK Messages	0...65535	Read only counter of good Modbus messages.					
3207	CRC Errors		Read only counter of CRC errors.					
3208	EFBUART Errors		Read only counter of UART errors.					
3209	EFB Status		Contains the status of Modbus protocol.					
		Idle	Drive is configured for Modbus, but not receiving any messages.					
		Exec. Init	Drive is initializing Modbus.					
		Time Out	A time-out has occurred .					
		Config Error	Drive has configuration error.					
		Off-line	Drive is receiving messages that are NOT addressed to itself.					
		On-Line	Drive is receiving messages that are addressed to itself.					
		Reset	Drive is performing hardware reset.					
Listen Only	Drive is in listen only mode.							

# PARAMETER LISTINGS

				Defaults				
Group 32	Modbus Setup	Range	Description	Single Pump	Synchronous	Multi-Control	Constant Slave	Speed Control
3210-3220	EFB Parameters		Meaning and values of these parameters depend on the selected fieldbus protocol.					
Group 50	Motor Control	Range	Description	Single Pump	Synchronous	Multi-Control	Constant Slave	Speed Control
5001	Switching Freq	4, 8, 12 kHz	Sets the switching frequency for the drive.	4 kHz	4 kHz	4 kHz	4 kHz	4 kHz
Group 51	Maintenance Triggers	Range	Description	Single Pump	Synchronous	Multi-Control	Constant Slave	Speed Control
5101	Cooling Fan Trig	0.0...6553.5 kh	Sets the trigger point for the drive's cooling fan counter. 0.0 = disabled	20	20	20	20	20
5102	Cooling Fan Act	0.0...6553.5 kh	Defines the actual value of the drive's cooling fan counter. The parameter is reset by writing 0.0 to it.					
5103	Revolution Trig	0...65535 MRev	Sets the trigger point for the motor's accumulated revolutions counter. 0.0 = disabled	32000	32000	32000	32000	32000
5104	Revolution Act	0...65535 MRev	Defines the actual value of the motor's accumulated revolutions counter. The parameter is reset by writing 0 to it.					
5105	Run Time Trig	0.0...6553.5 kh	Sets the trigger point for the drive's run time counter. 0.0 = disabled	40	40	40	40	40
5106	Run Time Act		Displays actual run time.					
Group 99	Information	Range	Description	Single Pump	Synchronous	Multi-Control	Constant Slave	Speed Control
9901	FW Version	Axxx hex	Version of the firmware loaded to the AV.					
9902	Drive Rating	XXX Y	Indicates the drive's current and voltage rating. The format is XXXY, where: XXX = The nominal current rating in amps. If present an "A" indicates the decimal point in the rating for the current. Y = The voltage rating of the drive, where Y=2 indicates a 208...240 Volt rating and Y=4 indicates a 380...480 Volt rating.					

# PROGRAMMING

## Single Pump Programming (Pressure transducer)

Standard view of display in REM (remote) mode. You will see the reference pressure (REF PRESSURE), actual pressure (ACT PRESSURE) and motor frequency in HZ.

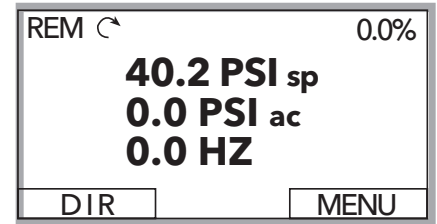

## RECOMMENDED INSTALLATION LAYOUT

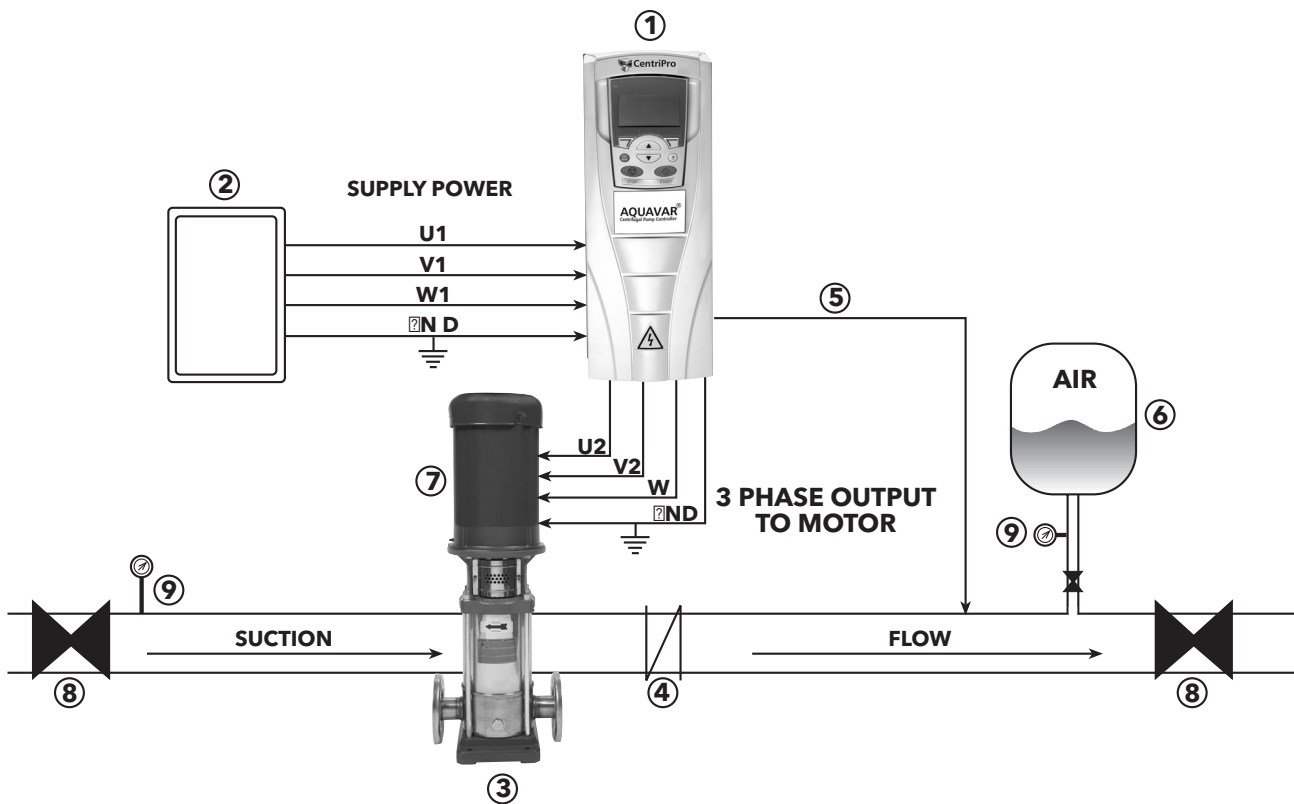

- |  |                           |
|--|---------------------------|
| ① AQUAVAR CPC                          | ⑥ AIR BLADDER TANK        |
| ② FUSIBLE DISCONNECT                   | ⑦ 3 PHASE MOTOR           |
| ③ CENTRIFUGAL PUMP                     | ⑧ GATE VALVE (BALL VALVE) |
| ④ CHECK VALVE (NON-SLAM TYPE)          | ⑨ PRESSURE GAUGE          |
| ⑤ PRESSURE TRANSDUCER (CABLE ASSEMBLY) |                           |

- NOTES:**
- A. Use of load filter (reactor) should be used between the Aquavar and motor, if motor leads exceed 60 wire feet.
  - B. If single phase power is supplied on 200 - 240 volt three phase units, use U1 and W1 as input terminals from single phase supply, and de-rate unit by 50% of three phase rating.
  - C. Tank size should be 10-20% (total volume) of flow in system. Pre-charge tank 10-15 PSI below system pressure.

# PROGRAMMING

## Single Pump Programming (Pressure transducer)

### Programming Step(s)

1. Access the main menu on the keypad. Press the MENU key once and the display will show (PARAMETERS, WIZARDS, CHANGED PAR). Using the arrow keys, highlight the "parameters" option, then press the "ENTER" key .

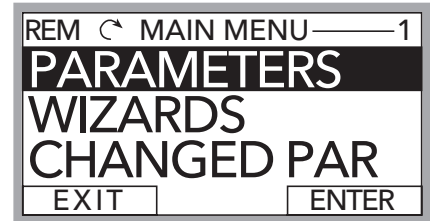

2. Once the parameters option has been chosen, the parameter groups will be displayed. Each group will be numbered (see parameter groups list on page 50 for detailed information). Use the arrow keys to highlight the parameter group 10, "LOCKS/PASSWORDS, then press the SEL key.

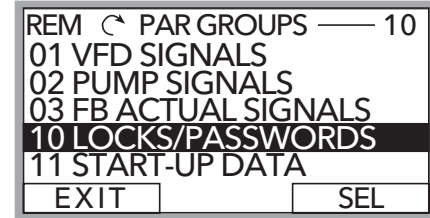

3. Use the arrow keys to highlight group 1002 "PASSCODE", then press the EDIT key. Enter your factory password number (Default is 66). Press the save key.

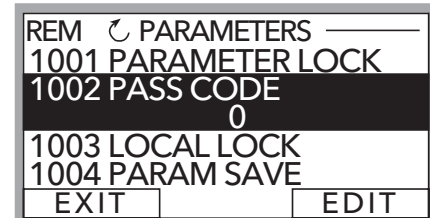

4. Use up arrow to group 1001 "PARAMETER LOCK", then press the EDIT key. Next, use the up arrow to select "OPEN", then press the SAVE key. This group should appear as "OPEN", if it does not you have entered the pass code incorrectly, or it has changed. Contact your local CentriPro representative for the master code. Once your group 1001 is showing "OPEN", you can access all of the pump and drive parameters in the Aquavar.



5. After the SAVE key is pressed in the above group, press the EXIT key, then the down arrow to highlight the group 11 "START UP DATA", then Press the SEL key once. Using the arrows, highlight 1102 "APPLIC MACRO", then press the EDIT key. Default is set for SINGLE PUMP. Change this group whether your system is Single Pump, Multi-Pump, Slave Pump etc. To exit press CANCEL, to save this parameter, press the SAVE key once.

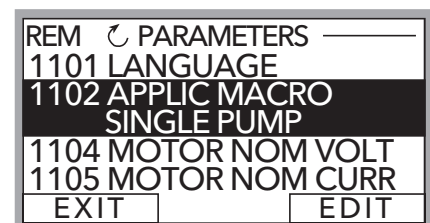

6. Use down arrow until group parameter 1104 "MOTOR NOM VOLTAGE" is highlighted, then press EDIT. Use the arrows to enter your motors nameplate voltage, then press the SAVE key.

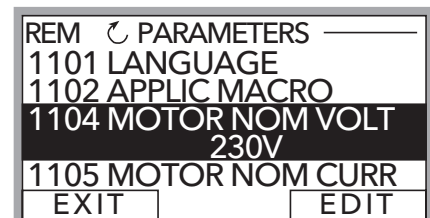

# PROGRAMMING

## Single Pump Programming (Pressure transducer)

7. Use the down arrow until group parameter 1105 "MOTOR NOM CURRENT" is highlighted, then press EDIT. Using arrows, enter your motor's maximum allowed amp draw at speed, or Service Factor Amps. **NOTE:** Enter motors service factor from nameplate or motor manual. Once you have entered the amps, press the SAVE key.

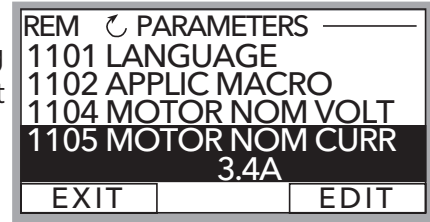

8. Use down arrow until you highlight group parameter 1107 "MOTOR NOM RPM", then press the EDIT key. Use arrows to enter the RPM from the motor nameplate, default is 3550 RPM. Press the SAVE key to store setting.

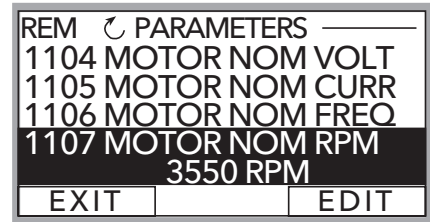

9. Use down arrow until you highlight group parameter 1108 "MOTOR NOM POW", then press the EDIT key. Use arrows to enter the motors Horsepower rating from nameplate, then press the SAVE key.

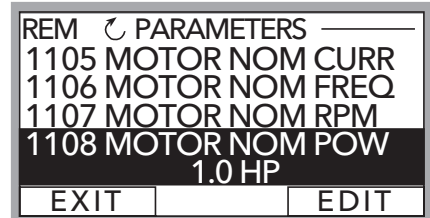

10. Once you have saved parameter 1108, use the down arrow until you highlight group parameter 1201 "START/STOP", then press EDIT. Default is "KEYPAD". This parameter determines how the operator will control the Aquavar; via the keypad or via MODBUS communication. If no changes are required, press the CANCEL key then EXIT and go to the next step.

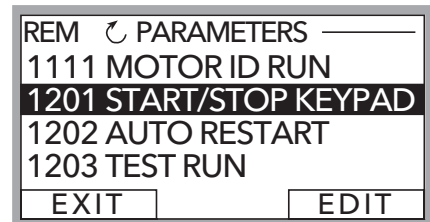

11. From group 12, press the down arrow until group 14 "SPD LIM/STRT LVL" is highlighted, then press EDIT. Use down arrows to highlight group 1402 "MINIMUM FREQ", then press EDIT. Using the arrow keys select the appropriate minimum speed in HZ. Default is 10% of the parameter 1106 MOTOR NOM FREQ which is 6 HZ. For a submersible motor or suction lift situation, this would be set to at least 30 HZ. For a positive suction booster system, leave at the default setting. Once changed, press the SAVE key to store the setting.

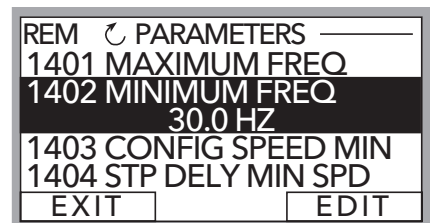

# PROGRAMMING

## Single Pump Programming (Pressure transducer)

12. From group 1402, press the down arrow until group 1502 TRANSDUCER MAX is highlighted, then press EDIT. Default pressure transducer setting is 300 psi. Adjust this based on your maximum rating for a new transducer. NOTE: CentriPro provides a 0 -300 psi transducer as standard. Select the appropriate range, then press SAVE. If no changes are necessary, press CANCEL.

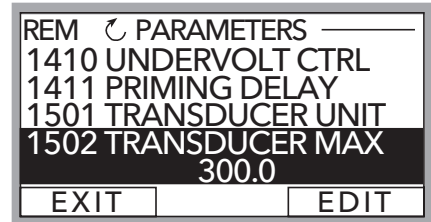

13. Use the down arrow to highlight 1503 "TRANSDUCER MIN" 0.0 , then press EDIT. Default should be 0 psi. Press CANCEL to advance to the next step. If this group needs to be changed based on another type of transducer value, press SAVE to store.

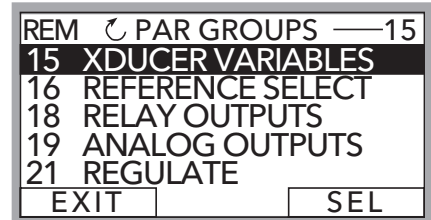

14. Use the down arrow to highlight 1506 "SENSOR MIN", then press EDIT. Use the up arrow until the "TUNE" value is displayed, press the SAVE key. This provides the transducer a tune value of 0 (ZERO) psi. **NOTE: Make sure that your transducer is wired to the Aquavar but free from any pressure in the system.** The transducer must be exposed to 0 psi only when this step is performed. Press the SAVE key to tune your transducer.

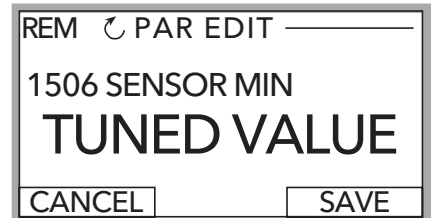
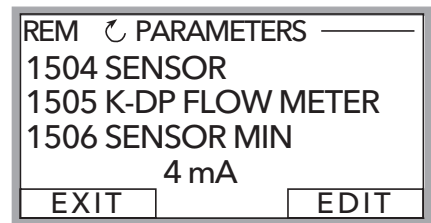

15. Final step is to enter your required pressure in the system. After above programming has been completed, press the EXIT key three (3) times, until you arrive back to the first control display screen. Then press the UP or DOWN arrow to select the required system pressure. Once pressure has been selected, press the green START key on the keypad.

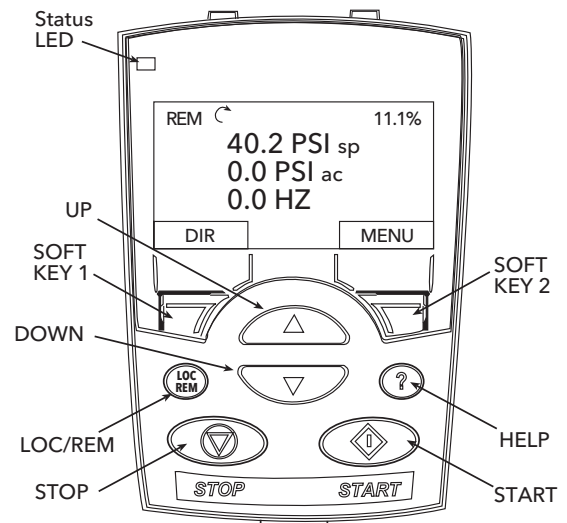

# PROGRAMMING

## Single Pump Programming (Pressure transducer)

16. **Optional Step:** To lock out access to the control panel (keypad), refer to page 109. This will prevent unauthorized users from changing programming.

**NOTE:** If an error or fault occurs, refer to the troubleshooting/faults section of this manual, page 116. When troubleshooting an Aquavar system, always break down into the following components:

1. **Aquavar programming** – check default settings recommended for single pump, multi-pump, slave pump etc.
2. **Electrical supply/ motor/ wiring/grounding** – check your supply voltage, motor wiring, transducer wiring, and grounding.
3. **Mechanical/Pump/ Rotation** – check your pump rotation, rubbing or other mechanical problems. Pump “run out”.
4. **Hydraulic System/ Piping** – check to ensure proper suction and discharge piping layout, proper NPSHa, air entrainment, vortex, friction loss, system curve compensation etc.
5. **Environment** – protect from high temperatures, direct sun, freezing temperatures, high altitude, dust, vibration, lack of air flow.



# PROGRAMMING

## Single Pump - Submersible Pump Constant Pressure

### SINGLE PUMP SUBMERSIBLE CONSTANT PRESSURE LAYOUT

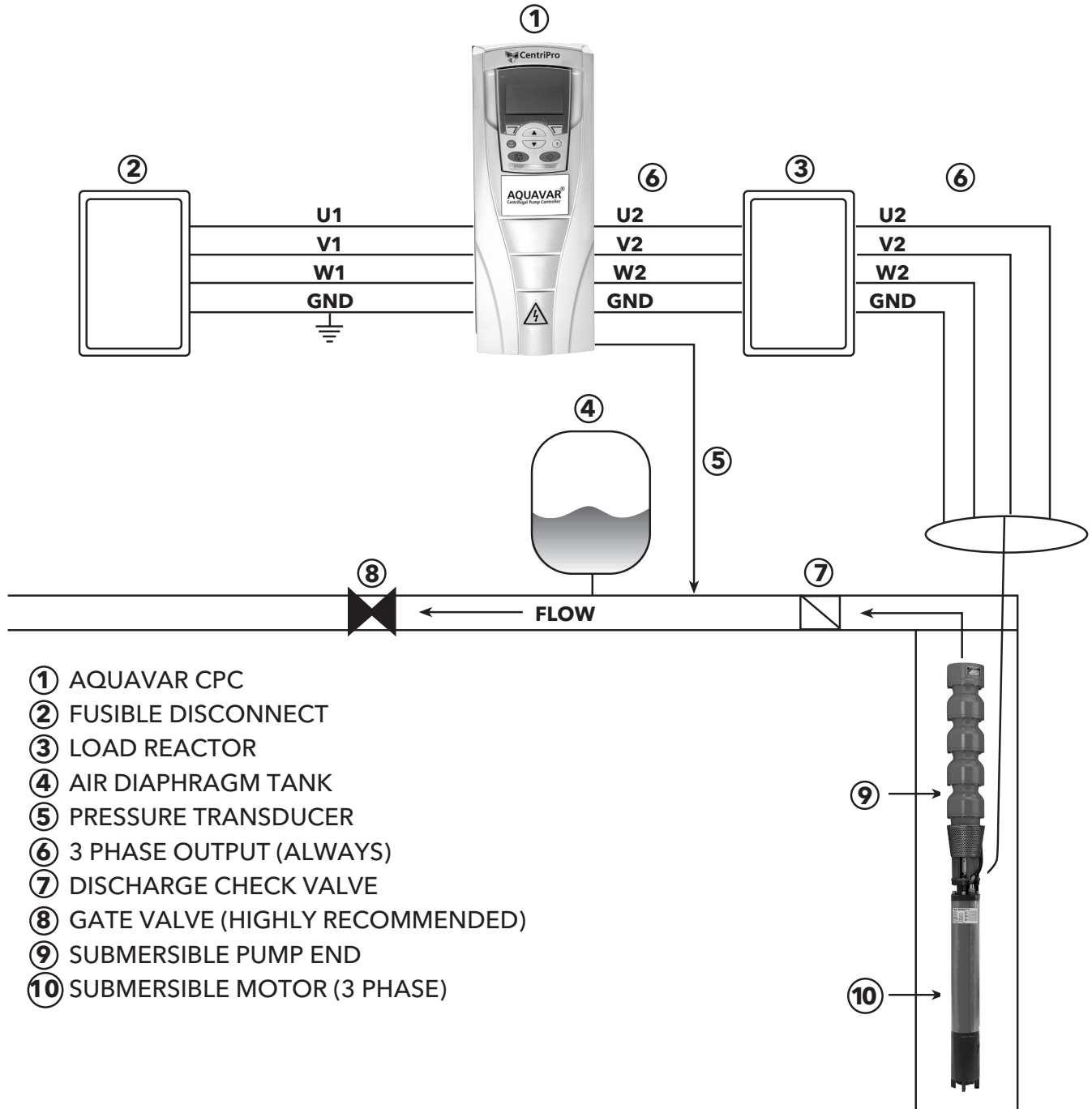

# PROGRAMMING

## Single Pump - Submersible Pump Constant Pressure

It is possible to utilize the Aquavar® Centrifugal Pump Controller on commercial/industrial well and submersible turbine applications. Submersible pumps and motors require specific installation, programming and pipe layout compared to above ground booster pump systems. However, specific programming must be followed to meet minimum requirements set forth by the motor manufacturer (i.e. Franklin Electric). Always consult with the appropriate motor technical manual for motor compatibility and requirements when using a Variable Frequency type drives.

**NOTE:** THE AQUAVAR IS NOT RECOMMENDED FOR RESIDENTIAL WELL APPLICATIONS. CONSULT CENTRIPRO FOR SUITABLE VARIABLE SPEED CONTROLLERS DESIGNED FOR RESIDENTIAL WELL PUMPS (e.g. BF15 series).

### Service Factor Amps

The submersible pump will sometimes utilize the motor service factor or MAX AMPS. Therefore, during peak use times, it is recommended to select the appropriate Aquavar based on the MOTOR MAXIMUM AMPS or **service factor amps**. Normally, this can be found on the motor nameplate or the AIM (application, installation manual). This will avoid nuisance tripping or current overload by the Aquavar. The Aquavar is designed to protect the motor on overcurrent! Compare the motor max amps with the list of Aquavar models.

**NOTE:** ALL MOTORS MUST BE THREE PHASE.

### Minimum Frequency

Submersible pump motors require a minimum speed or frequency to operate properly. Because submersible motors use the water to lubricate and cool, they require this minimum frequency when controlled by a Variable Speed Drive. Franklin has suggested that the **Minimum Frequency** is set to at least 30 HZ in the Aquavar. Therefore, it is recommended to set the Aquavar Minimum Frequency to 30 to 35 HZ (depending on static head) in programming group 1402. See programming section.



**WARNING:** FAILURE TO SET THE MINIMUM FREQUENCY FOR SUBMERSIBLE TURBINE INSTALLATION COULD RESULT IN DAMAGE TO THE PUMP AND/OR MOTOR.

### Tank Sizing

An appropriate size diaphragm tank must be sized for smooth operation. The tank will also provide a needed compressibility at zero flow. A tank with approximately 20% of total system volume in GPM would be recommended.

# PROGRAMMING

## Single Pump - Submersible Pump Constant Pressure

### Load Reactor (Filter)

A Load reactor or load filter is an electrical device that provides protection to the motor windings from a specific variable speed drive. Motors are more susceptible to voltage “spikes” and switching frequencies found in IGBT type drives, especially when the motor leads exceed 50 ft. Therefore, a load reactor is required when **all** of the following conditions are met for ANY type of AC induction motor (above ground or submersible type):

1. Motor cable length from the Aquavar to the motor is more than 50 wire feet.
2. Drive uses IGBT type of switching (which is industry standard and is used by the **Aquavar**).

If all of the conditions are present above, then it is recommended to wire a LOAD REACTOR between the Aquavar output (U2, V2, W2) and the motor. Keep the load reactor as close to the output of the Aquavar for best results. NOTE: See suggested layout drawing and always refer to your specific motor manufacturers recommendation for VFD's.

### Grounding

**NOTE:** Always follow local codes for wiring and grounding or refer to the National Electrical Codes.

Submersible installations are susceptible to stray voltage or grounding problems. It is recommended to ground the transducer shield to the chassis of the Aquavar cabinet and to check with a meter for any stray voltage from the three phase motor. Each component of the electrical Aquavar system should have the same grounding point or reference. Always follow the submersible motor manufacturer's recommended installation procedures.

#### NOTES:

- ✓ Motors used must be three phase, equal to input voltage.
- ✓ Standard enclosure is rated for NEMA 1 INDOOR USE ONLY. Consult Factory/ Price pages for outdoor rated enclosures.
- ✓ Aquavar CPC not for use on RESIDENTIAL WELL PUMP applications. Consult with factory for appropriate variable speed controller like the BF15.
- ✓ Input voltage for the Aquavar can be single phase. Use the U1 , W1 and Ground connections, and derate the drive by 50% from the three phase rating. Example: 230 volt, three phase 10 HP Aquavar becomes a 5 HP, 230 volt, single phase rated drive.

# PROGRAMMING

## Single Pump - Submersible Pump Constant Pressure

Each component of the electrical Aquavar system should have the same grounding point or reference.

### Programming Step(s)

Standard view of the display in REM (remote) mode. You will see the reference pressure (REF PRESSURE), actual pressure (ACT PRESSURE) and motor frequency in HZ.

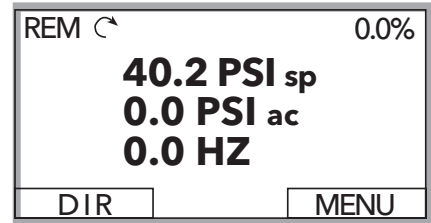

1. Access the main menu on the keypad. Press the MENU key once and the display will show (PARAMETERS, WIZARDS, CHANGED PAR). Using the arrow keys, highlight the "parameters" option, then press the "ENTER" key.



2. Once the parameters option has been chosen, the parameter groups will be displayed. Each group will be numbered (see parameter groups list on page 51 for detailed information). Use the arrow keys to highlight the parameter group 10, "LOCKS/PASSWORDS", then press the SEL key.

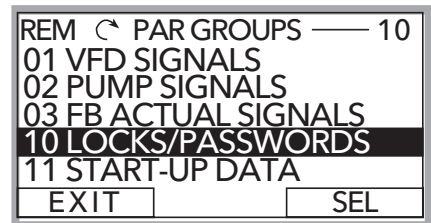

3. Use the arrow keys to highlight group 1002 "PASSCODE", then press the EDIT key. Using the up arrow, enter your factory password number (Default is 66). Press the save key.

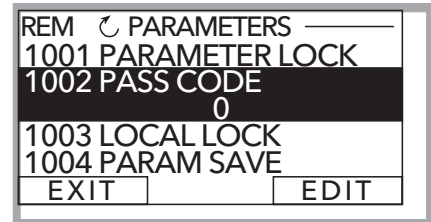

4. Use up arrow to group 1001 "PARAMETER LOCK", then press the EDIT key. Next, use the up arrow to select "OPEN", then press the SAVE key. This group should appear as "OPEN", if it does not you have entered the pass code incorrectly, or it has changed. Contact your local CentriPro representative for the master code. Once your group 1001 is showing "OPEN", you can access the entire pump and drive parameters in the Aquavar.

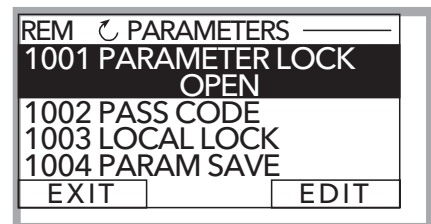

5. After the SAVE key is pressed in the above group, press the EXIT key, then the down arrow to highlight the group 11 "START UP DATA", then Press the SEL key once. Using the arrows, highlight 1102 "APPLIC MACRO", then press the EDIT key. Default is set for SINGLE PUMP. Change this group whether your system is Single Pump, Multi-Pump, Slave Pump etc. To exit press CANCEL, to save this parameter, press the SAVE key once.

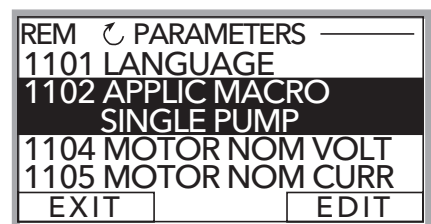

# PROGRAMMING

## Single Pump - Submersible Pump Constant Pressure

6. Use down arrow until group parameter 1104 "MOTOR NOM VOLTAGE" is highlighted, then press EDIT. Use the arrows to enter your motors nameplate voltage, then press the SAVE key.

REM	⌂	PARAMETERS	_____
1101	LANGUAGE		
1102	APPLIC MACRO		
1104	MOTOR NOM VOLT		
	230V		
1105	MOTOR NOM CURR		
EXIT			EDIT

7. Use the down arrow until group parameter 1105 "MOTOR NOM CURRENT" is highlighted, then press EDIT. Using the arrows, enter your motor's maximum allowed amp draw at speed, or Service Factor Amps. **NOTE:** Enter motor service factor from nameplate or motor manual. Once you have entered the amps, press the SAVE key.

REM	⌂	PARAMETERS	_____
1101	LANGUAGE		
1102	APPLIC MACRO		
1104	MOTOR NOM VOLT		
1105	MOTOR NOM CURR		
	3.4A		
EXIT			EDIT

8. Use down arrow until you highlight group parameter 1107 "MOTOR NOM RPM", then press the EDIT key. Use arrows to enter the RPM from the motor nameplate, default is 3550 RPM. Press the SAVE key to store setting.

REM	⌂	PARAMETERS	_____
1104	MOTOR NOM VOLT		
1105	MOTOR NOM CURR		
1106	MOTOR NOM FREQ		
1107	MOTOR NOM RPM		
	3550 RPM		
EXIT			EDIT

9. Use down arrow until you highlight group parameter 1108 "MOTOR NOM POW", then press the EDIT key. Use arrows to enter the motors Horsepower rating from nameplate, then press the SAVE key.

REM	⌂	PARAMETERS	_____
1105	MOTOR NOM CURR		
1106	MOTOR NOM FREQ		
1107	MOTOR NOM RPM		
1108	MOTOR NOM POW		
	1.0 HP		
EXIT			EDIT

10. Once you have saved parameter 1108, use the down arrow until you highlight group parameter 1201 "START/STOP", then press EDIT. Default is "KEYPAD". This parameter determines how the operator will control the Aquavar; via the keypad or via MODBUS communication. If no changes are required, press the CANCEL key then EXIT and go to the next step.

REM	⌂	PARAMETERS	_____
1111	MOTOR ID RUN		
1201	START/STOP KEYPAD		
1202	AUTO RESTART		
1203	TEST RUN		
EXIT			EDIT

11. From group 12, press the down arrow until group 14 "SPD LIM/STRT LVL" is highlighted, and then press SEL. Use down arrows to highlight group 1402 "MINIMUM FREQ", then press EDIT. Using the arrow keys select the appropriate minimum speed in HZ. Default is 10% of the parameter 1106 MOTOR NOM FREQ which is 6 HZ. For a submersible motor or suction lift situation, this would be set to at least 30 HZ.

REM	⌂	PARAMETERS	_____
1401	MAXIMUM FREQ		
1402	MINIMUM FREQ		
	30.0 HZ		
1403	CONFIG SPEED MIN		
1404	STP DELY MIN SPD		
EXIT			EDIT

Depending upon the static water level, and pipe distance to the transducer, you may have to increase this setting up to 40HZ. Once changed, press the SAVE key to store the setting.

# PROGRAMMING

## Single Pump - Submersible Pump Constant Pressure

12. Next step will set the appropriate time delay in seconds at the MINIMUM FREQUENCY. Use the down arrow until you highlight parameter 1404 STP DELY MIN SPD, and then press the EDIT key. Use the UP ARROW to select a time in seconds. A suggested delay time is 5 seconds. When the pump reaches the minimum frequency, it will have a delay of 5 seconds before shutting down. Once entered, then press the SAVE key.

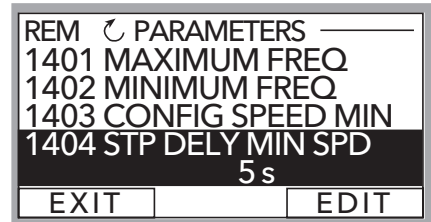

13. From group 1404, press the down arrow until group 1502 TRANSDUCER MAX is highlighted, then press EDIT. Default pressure transducer setting is 300 psi. Adjust this based on your maximum rating for a new transducer. **NOTE:** CentriPro provides a 0 -300 psi transducer as standard. Select the appropriate range, then press SAVE. If no changes are necessary, press CANCEL.

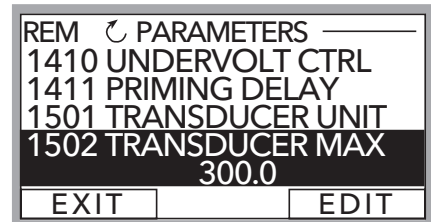

14. Use the down arrow to highlight 1503 "TRANSDUCER MIN" 0.0 , then press EDIT. Default should be 0 psi. Press CANCEL to advance to the next step. If this group needs to be changed based on another type of transducer valve, press SAVE to store.

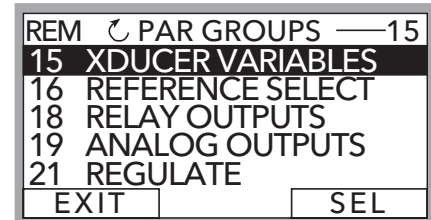

15. Use the down arrow to highlight 1506 "SENSOR MIN", then press EDIT. Use the up arrow until the "TUNE" value is displayed, press the SAVE key. This provides the transducer a tune value of 0 (ZERO) psi.

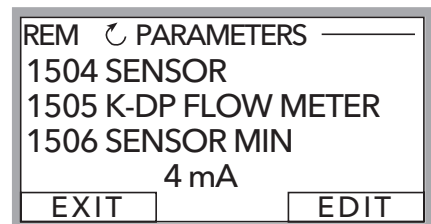

**NOTE:** Make sure that your transducer is wired to the Aquavar but free from any pressure in the system. The transducer must be exposed to 0 psi when this step is performed. Press the SAVE key to tune your transducer.

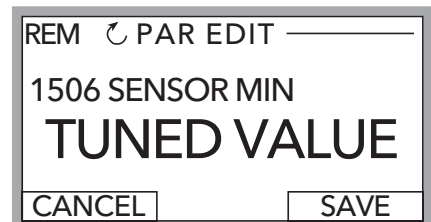

# PROGRAMMING

## Single Pump - Submersible Pump Constant Pressure

16. Final step is to enter your required pressure in the system. After above programming has been completed, press the EXIT key three (3) times, until you arrive back to the first control display screen. Then press the UP or DOWN arrow to select the required system pressure. Once pressure has been selected, press the green START key on the keypad.

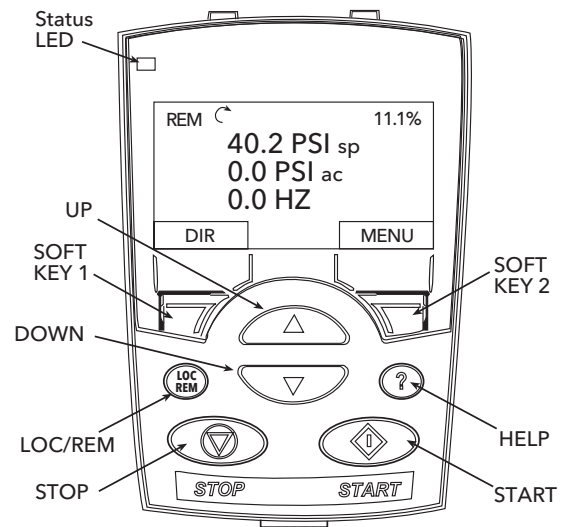

17. **Optional Step:** To lock out access to the control panel (keypad), refer to page 109. This will prevent unauthorized users from changing programming.

**NOTE:** If an error or fault occurs, refer to the troubleshooting/faults section of this manual, page 116. When troubleshooting an Aquavar system, always break down into the following components:

1. **Aquavar programming** – check default settings recommended for single pump, multi-pump, slave pump etc.
2. **Electrical supply/ motor/ wiring/grounding** – check your supply voltage, motor wiring, transducer wiring, and grounding.
3. **Mechanical/Pump/ Rotation** – check your pump rotation, rubbing or other mechanical problems. Pump “run out”.
4. **Hydraulic System/ Piping** – check to ensure proper suction and discharge piping layout, proper NPSHa, air entrainment, vortex, friction loss, system curve compensation etc.
5. **Environment** – protect from high temperatures, direct sun, freezing temperatures, high altitude, dust, vibration, lack of air flow.



# PROGRAMMING

## SINGLE-PUMP LEVEL CONTROL

### Submersible Transducer Setup

#### PARAMETER SETTINGS QUICK LIST

- 1002** – Pass Code = 66
- 1001** – Parameter Lock = OPEN
- 1102** – Application Macro = SINGLE PUMP
- 1104** – Motor Nom. Volt.
- 1105** – Motor Nom. Current
- 1106** – Motor Nom. Freq.
- 1107** – Motor Nom. RPM
- 1108** – Motor Nom. Pow.
- 2101** – Regulation Mode = INVERSE
- 1501** – Transducer Unit = FT

#### SYSTEM TUNING

**Group 13** – Ramps allow for tuning of the system response. Ramps 1 and 2 provide control of start and stop ramps and can be used to produce smooth operation throughout pumping level. Ramps 3 and 4 work within the regulation window to provide a final adjustment of system operation when needed (reference pages 107-111).

**NOTE:** Level control application performance is dependant on sump size, maximum flow rate and pump selection. An oversized pump may produce on/off type system operation, similar to a level switch. This condition might not be fully correctable with ramp control.



# PROGRAMMING

## MULTI-PUMP LEVEL CONTROL

### Submersible Transducer Setup

#### PARAMETER SETTINGS QUICK LIST

- 1002** – Pass Code = 66
- 1001** – Parameter Lock = OPEN
- 1102** – Application Macro = MULTIPUMP
- 1104** – Motor Nom. Volt.
- 1105** – Motor Nom. Current
- 1106** – Motor Nom. Freq.
- 1107** – Motor Nom. RPM
- 1108** – Motor Nom. Pow.
- 2101** – Regulation Mode = INVERSE
- 1501** – Transducer Unit = FT
- 2207** – Pump Address = 1, 2, 3 or 4

#### SYSTEM TUNING

**Group 13** – Ramps allow for tuning of the system response. Ramps 1 and 2 provide control of start and stop ramps and can be used to produce smooth operation throughout pumping level. Ramps 3 and 4 work within the regulation window to provide a final adjustment of system operation when needed (reference pages 112-114).

**NOTE:** Level control application performance is dependant on sump size, maximum flow rate and pump selection. An oversized pump may produce on/off type system operation, similar to a level switch. This condition might not be fully correctable with ramp control.

# PROGRAMMING

## MultiPump - Constant Pressure Control

### Overview

The Aquavar CPC has the ability to connect and control up to four centrifugal pumps, to form a Multi-Pump, lead-lag and alternating pumping system. This will allow the operator to maintain a constant pressure through a larger system flow range, and provides equal wear for the pumps and motors. The Aquavar units will be hard wired together via the RS485 terminals (29,30,31), and provide communication to maintain a constant pressure to the system. Once the lead pump cannot maintain a certain pressure and allows a slight pressure drop, the next (lag) pump will turn on and vary the speed according to the flow demand. This sequencing can be programmed according to the specific system requirements, and is field adjustable. If a pump or controller fails, the next pump will automatically turn on in its place. Each Aquavar controlled pump will provide a fully functional lead/lag and automatic alternation system, with automatic back up control when required.

### System Curve - Friction Compensation

It is possible to program the Aquavar to maintain a constant pressure, and compensate for increasing friction loss according to a system curve. As the flow rate increases in the system, the friction loss will increase as well. The Aquavar can compensate for this friction loss with the simple adjustment of the parameter 2202 "VALUE INCREASE". When each Aquavar unit enables the pump, it will increase the system pressure by the programmed amount. This pressure is additive with each additional pump. Therefore, if you set this parameter for 3 psi, and you initial constant pressure is 50 psi, and you have 4 pumps total:  $(50 \text{ psi} + 3 \text{ psi} + 3 \text{ psi} + 3 \text{ psi}) = 59 \text{ psi}$  when all 4 pumps are operating at full speed. This final system pressure should be enough to overcome your calculated head and friction loss, and to provide constant pressure at the end of the pipe run. **NOTE: This program function is not intended for substitution of proper pipe layout and sizing according to Hydraulic Institute Standards. This feature may not work for excessive friction losses!**

### Pump Sequencing

The Aquavar CPC has the ability to operate in a multiple pump with lead and lag pumps. Each Aquavar will be given an address then operate as Pump 1, Pump 2, Pump 3 or Pump 4. When Pump 1 cannot maintain the required system pressure and the speed reaches 60 Hz, then that will trigger the lag pump to come on and help maintain the set pressure. In order for the lag pump to turn on, the lead pump must be at full speed (Maximum Frequency) and programmed system pressure drop must be met (VALUE DECREASE). Each Aquavar controlled pump will vary its speed according to the demand on the entire system. In a Duplex System, you could have Pump 1 running at full speed 60 Hz, and Pump 2 running at 50 Hz in order to maintain the system pressure at the flow demand. Each pump will operate in a sequential mode, when called.

# PROGRAMMING

## MultiPump - Constant Pressure Control

### Wiring/Connection RS485

Each Aquavar unit must be connected via terminals 29, 30 and 31. Using a three wire shielded cable between each Aquavar terminal. **Suggested wire specifications would be 3 or 4 wire, 22AWG, one pair shielded, TYPE CM or CL3, 75 degree C(UL).** Remember to keep the color coded wires the same to each terminal connection, and inspect for loose or bad connections.



When using all the same Aquavar CPC units, you must provide a BUS TERMINATION for the last drives in the multi-pump system. The RS485 has two yellow DIP SWITCHES that must be in the ON position when that Aquavar CPC unit is the last or first in the system. Therefore, if you have 4 pumps in multi-pump configuration, Aquavar address 1 and Aquavar address 4 would have their DIP SWITCHES in the ON position (see diagram). If you have a DUPLEX system, then Aquavar address 1 and Aquavar address 2 would have the switches in the ON position.

Always follow your local codes or National codes and have a certified electrician perform the necessary wiring.

**NOTE:** Fieldbus cannot be used with RS485 multipump (Modbus, Devicenet, Profibus). Single pump only!



X1	Identification	Hardware Description <sup>1</sup>	
28	Screen	<div style="display: flex; justify-content: space-around;"> <div style="text-align: center;"> <p><b>RS485 Multidrop Application</b> Other Modbus Devices</p> </div> <div style="text-align: center;"> <p><b>RS485 Interface</b></p> <p>off position    on position Bus Termination</p> </div> </div>	
29	B		
30	A		
31	AGND		
32	Screen		

Multipump Connections for each Aquavar

<sup>1</sup> For functional descriptions, see "Standard Serial Communication" addendum.

# PROGRAMMING

## MultiPump - Constant Pressure Control

### Pump Sizing

It is recommended to use the same size pump for a multi-pump configuration. This is to ensure even distribution of flow rates especially when small flow demands are put on the system. If the operator requires a flow range of 10 - 500 GPM for the system, it would be recommended to select a TRIPLEX system, with each pump capable of a maximum of 167 GPM at the required TDH. (167 GPM x 3 pumps = 501 GPM ) A smaller sized pump is more capable of providing the low flow rates, rather than a larger pump that may oscillate more at the low flows. One of the immediate benefits is to have all the same pumps for parts and spares. No smaller jockey pumps. Each pump is evenly distributing the required flow and pressure. Remember to allow system friction losses at maximum flow!

### Tank Sizing

Similar to the single pump constant pressure system, the multi-pump system should have a diaphragm or bladder type tank for system cushion. The tank should be rated for the maximum system pressure, and be sized for 10-25% of the single pump capacity. This is total tank volume, not drawdown. If you have a triplex system of 167 GPM per pump capacity, then your tank size should be a minimum of 17 Gallon capacity. **Go to the next higher tank volume if you have a suction lift or flooded suction.** The tank provides small drawdown capacities on drive start up and provides a "cushion" for the entire system at normal operation and will provide compressibility at shut-down. The tank pressure will greatly improve system operation. A larger tank is acceptable and sometimes required, just do not exceed 50% volume of the flow for one pump, this may cause system problems.

### Programming

The following steps are for multi-pump, constant pressure systems, with up to four (4) Aquavar CPC. Each Aquavar CPC will have to be programmed according to this parameter guide. The parameters will not transfer over to each unit. There are two options for downloading the parameters into each Aquavar:



- A)** Manually entering each parameter into the Aquava control panel/display with the following steps.
- B)** Using the first Aquavar control panel, you can download the software to each additional Aquavar via the control panel. Take the programmed control panel from Aquavar #1, then insert and replace each additional control panel for Aquavar #2, #3, #4. This will automatically download saved parameters into the other Aquavar units. See diagram to the left.

# PROGRAMMING

## MultiPump - Constant Pressure Control

### Programming Step(s)

Standard view of the display in REM (remote) mode. You will see the reference pressure (REF PRESSURE), actual pressure (ACT PRESSURE) and motor frequency in HZ.

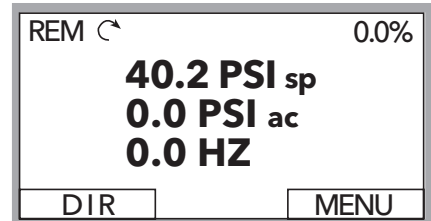

1. Access the main menu on the keypad. Press the MENU key once and the display will show (PARAMETERS, WIZARDS, CHANGED PAR). Using the arrow keys, highlight the "parameters" option, then press the "ENTER" key.

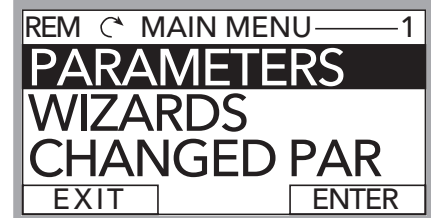

2. Once the parameters option has been chosen, the parameter groups will be displayed. Each group will be numbered (see parameter groups list on page 51 for detailed information). Use the arrow keys to highlight the parameter group 10, "LOCKS/PASSWORDS", then press the SEL key.

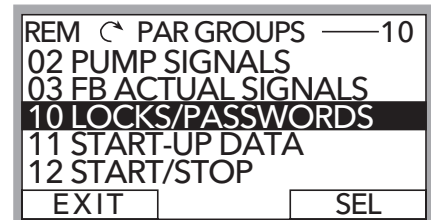

3. Use the arrow keys to highlight group 1002 "PASSCODE", then press the EDIT key. Using the up arrow, enter your factory password number (Default is 66). Press the save key.

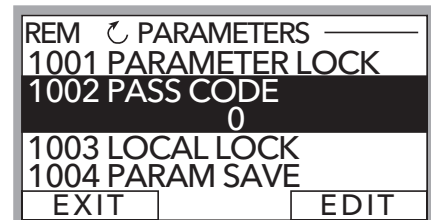

4. Use up arrow to group 1001 "PARAMETER LOCK", then press the EDIT key. Next, use the up arrow to select "OPEN", then press the SAVE key. This group should appear as "OPEN", if it does not you have entered the pass code incorrectly, or it has changed. Contact your local CentriPro representative for the master code. Once your group 1001 is showing "OPEN", you can access the entire pump and drive parameters in the Aquavar.

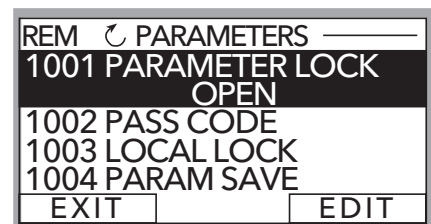

5. After the SAVE key is pressed in the above group, press the EXIT key, then the down arrow to highlight the group 11 "START UP DATA", then Press the SEL key once. Using the arrows, highlight 1102 "APPLIC MACRO", then press the EDIT key. Using the UP arrow, highlight "MULTICONTROL" option, then press the SAVE key.

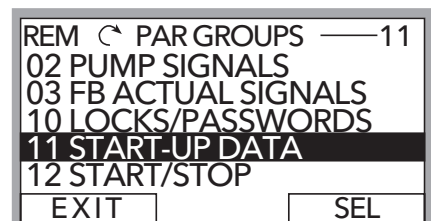

# PROGRAMMING

## MultiPump - Constant Pressure Control

6. Use down arrow until group parameter 1104 "MOTOR NOM VOLTAGE" is highlighted, then press EDIT. Use the arrows to enter your motors nameplate voltage, then press the SAVE key.

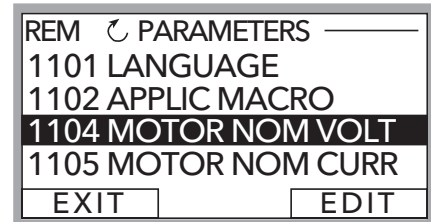

7. Use the down arrow until group parameter 1105 "MOTOR NOM CURRENT" is highlighted, then press EDIT. Using the arrows, enter your motor's maximum allowed amp draw at full speed, or Service Factor Amps. **NOTE:** Enter motors service factor from nameplate or motor manual. Once you have entered the amps, press the SAVE key.

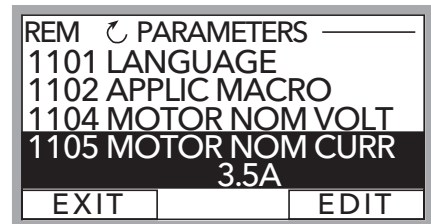

8. Use down arrow until you highlight group parameter 1107 "MOTOR NOM RPM", then press the EDIT key. Use arrows to enter the RPM from the motor nameplate, default is 3550 RPM. Press the SAVE key to store setting.

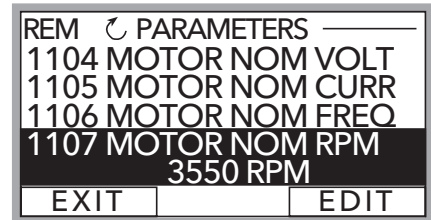

9. Use down arrow until you highlight group parameter 1108 "MOTOR NOM POW", then press the EDIT key. Use arrows to enter the motors Horsepower rating from nameplate, then press the SAVE key.

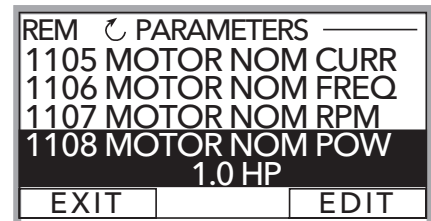

10. After saving your motor horsepower, press the EXIT key. Use the down arrow until you highlight the Group 15 "XDUCER VARIABLES", then press SEL.

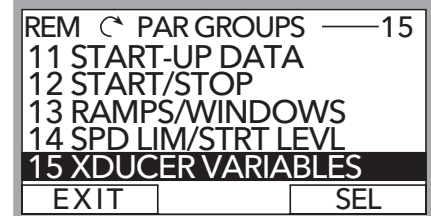

11. Press the down arrow until parameter 1502 "TRANSDUCER MAX" is highlighted, then press EDIT. Default pressure transducer setting is 300 psi. Adjust this based on your maximum rating for a new transducer. **NOTE:** CentriPro provides a 0-300 psi transducer as standard. Always check the maximum range of your transducer before proceeding. Select the appropriate range, then press SAVE. If no changes are necessary, press CANCEL.

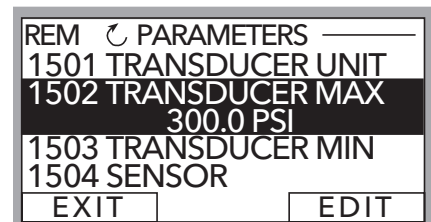



# PROGRAMMING

## MultiPump - Constant Pressure Control

12. Use the down arrow to highlight 1503 "TRANSDUCER MIN" 0.0 , then press EDIT. Default should be 0 psi. Press CANCEL to advance to the next step. If this group needs to be changed based on another type of transducer value, press SAVE to store.

13. Use the down arrow to highlight 1506 "SENSOR MIN", then press EDIT. Use the up arrow until the "TUNE" value is displayed, press the SAVE key. This provides the transducer a tuned value of 0 (ZERO) psi. **NOTE: Make sure that your transducer is wired to the Aquavar but free from any pressure in the system.** The transducer must be exposed to 0 psi when this step is performed. Press the SAVE key to tune your transducer.

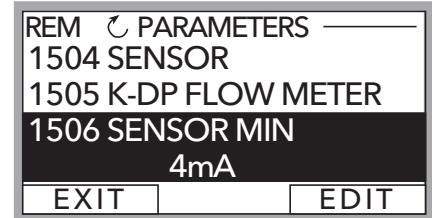

14. Once you have saved the parameter 1506, press the EXIT key. Use down arrow until you highlight parameter Group 22 "MULTIPUMP CTRL" Then press the SEL key.

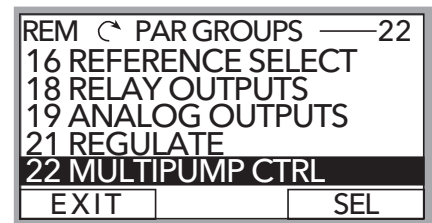

15. After above step, you should have parameter 2201 "VALUE DECREASE" highlighted. Press the EDIT once. Uses the up or down arrow to select the allowable pressure drop before the next lag pump comes on. (Example: If the first pump reaches maximum frequency, and the pressure drop allowed before the lag pump turns on is 3 psi, you would set this parameter for 3.0 psi). Once a pressure is set in 2201, then press the SAVE key.

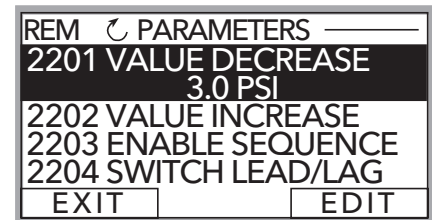

16. Use the down arrow to highlight parameter 2202 "VALUE INCREASE" then press EDIT. Use the UP or DOWN arrow to set your system pressure curve compensation. If you do not require friction loss compensation at maximum frequency, then enter 0 psi. Then press the SAVE key. (**NOTE:** System friction loss or overcoming head loss, can be compensated by setting this parameter for each pump. This value increase is additive for each lag pump).

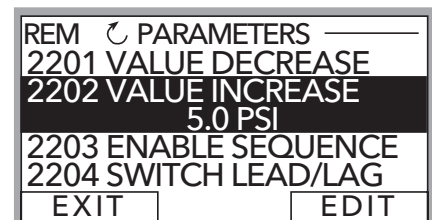

17. Once parameter 2202 has been saved, use the DOWN arrow to highlight parameter 2203 "ENABLE SEQUENCE" then press the EDIT key. Using the up or down arrows select the frequency in HZ that will turn the next lag pump on, when the lead pump has reached this frequency. Normal setting is 59 HZ, which allows the lag pump to start when the frequency has reached 59HZ on the lead pump, plus value decrease has been met). **NOTE: Always set this parameter at or BELOW the MAXIMUM FREQUENCY).** If no changes from default are required, press the CANCEL key.

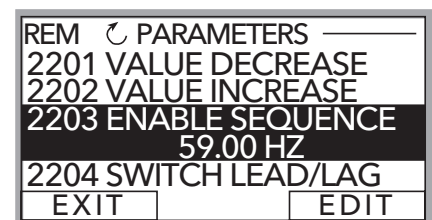

# PROGRAMMING

## MultiPump - Constant Pressure Control

18. After 2203 has been selected, press the down arrow to highlight parameter 2204 "SWITCH LEAD LAG". Press the EDIT key once. Using the up or down arrows, select the alternating time between lead and lag pumps. Once selected, press the SAVE key.

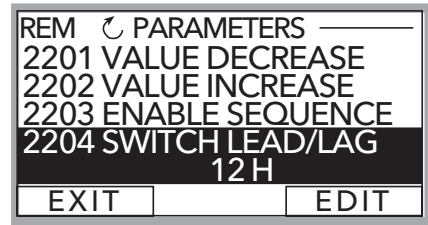

19. Once 2204 has been saved, press the down arrow to highlight "2207 PUMP ADDRESS". Press the EDIT key once. Use the up arrow to select your appropriate address for each pump. Always start with address one. Once each pump has a different address, press the SAVE key.

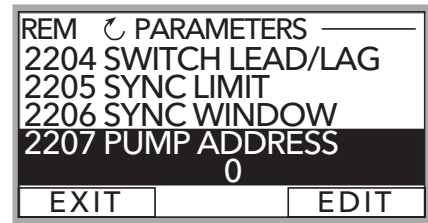

20. Final step is to enter your required system pressure. After above programming has been completed for each Aquavar controlled pump, press the EXIT key two (2) or three (3) times, until you arrive back to the first control display screen. (SEE DIAGRAM.) Then press the UP or DOWN arrow to select the required system pressure for your Aquavar controlled pump. Once pressure has been selected, press the green START key on the keypad.

21. **Optional Step:** To lock out access to the control panel (keypad), refer to page 104. This will prevent unauthorized users from changing programming.

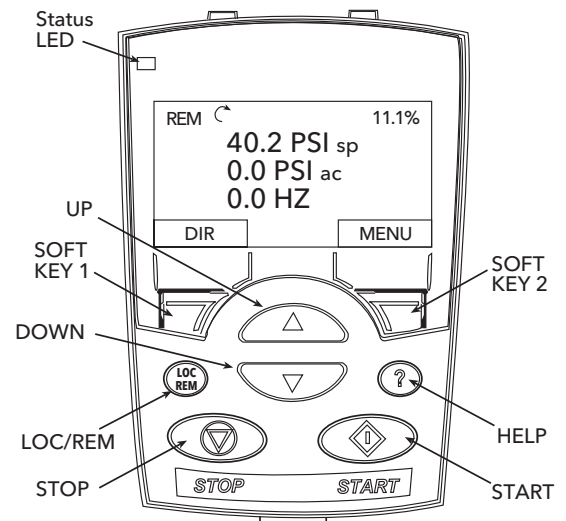

**NOTE:** If an error or fault occurs, refer to the troubleshooting/faults section of this manual. When troubleshooting an Aquavar system, always break down into the following components:

1. **Aquavar programming** – check default settings recommended for single pump, multi-pump, slave pump etc.
2. **Electrical supply/ motor/ wiring/grounding** – check your supply voltage, motor wiring, transducer wiring, and grounding.
3. **Mechanical/Pump/ Rotation** – check your pump rotation, rubbing or other mechanical problems. Pump "run out".
4. **Hydraulic System/ Piping** – check to ensure proper suction and discharge piping layout, proper NPSHa, air entrainment, vortex, friction loss, system curve compensation etc.
5. **Environment** – protect from high temperatures, direct sun, freezing temperatures, high altitude, dust, vibration, lack of air flow.



# PROGRAMMING

## MultiPump - Slave Pump Control

### AQUAVAR CPC (SLAVE PUMP) DIAGRAM

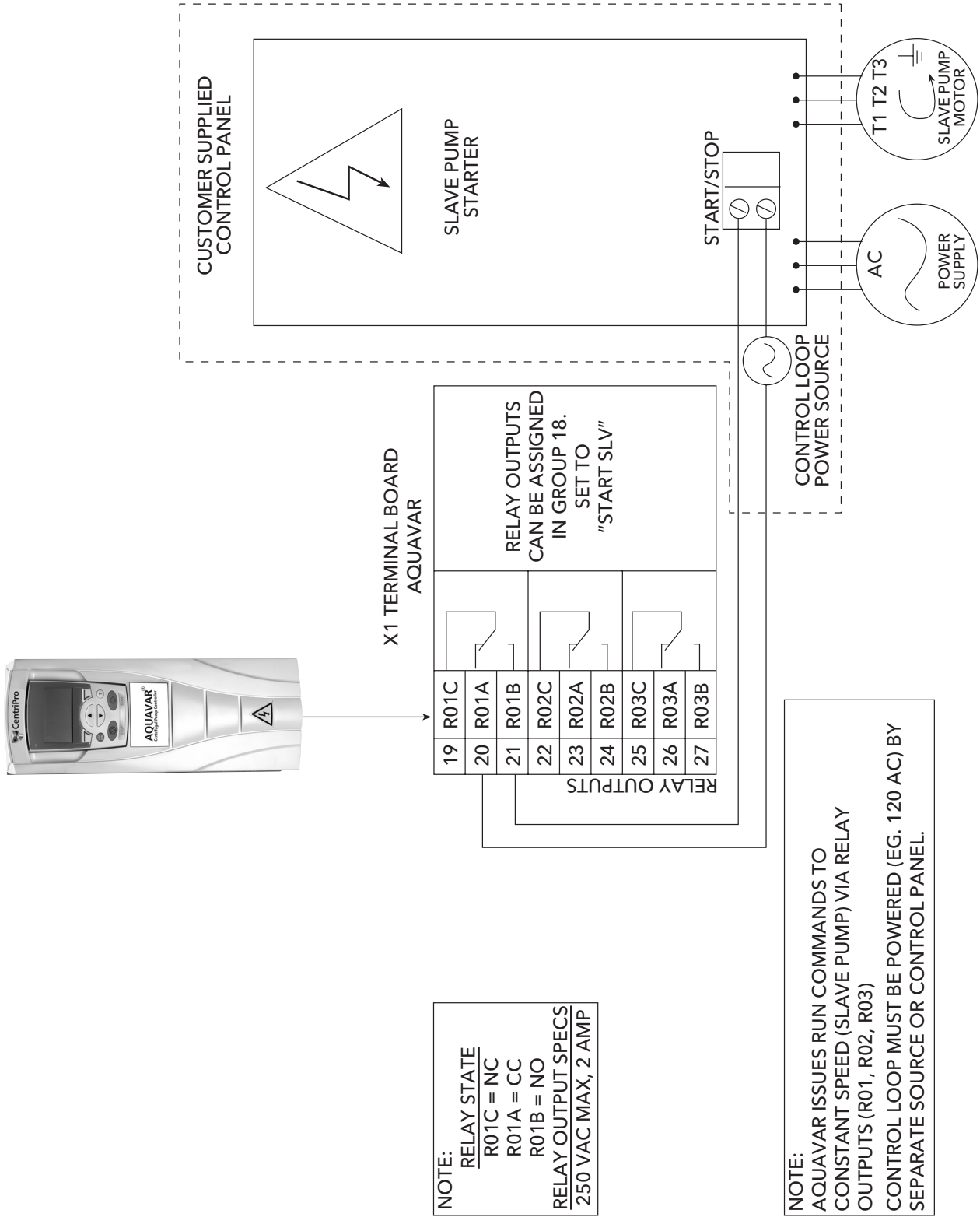

# PROGRAMMING

## MultiPump - Slave Pump Control

### Overview

The Aquavar CPC has the ability to use up to three “dry” relay contacts for constant speed “SLAVE” or lag pump control. This is useful if the operator requires a wide range of flow rates in certain situations (i.e. emergency flow), and does not require all variable speed controlled pumps. When the required demand increases beyond capacity of the variable speed controlled lead pump, then the FULL SPEED lag pump will turn on. Each relay will be wired to your constant speed pump starter, sized for the appropriate horsepower and voltage. The relay outputs located on the terminal control board X1 (SEE DIAGRAM FROM PREVIOUS PAGE) will actuate when programmed according to the operators desired output. The lag pumps will turn on when the Aquavar controlled pump cannot keep up to the required demand. The lag pumps will be operated by across the line starters, and signaled to start via the Aquavar relays located on terminal’s 19 through 27 of the X1 terminal block. The lag pumps are referred to as “SLAVE” pumps, because they operate with commands from the Aquavar controlled “LEAD” pump. The Aquavar controller will actuate the relays, and provide a time delay for ON/ OFF on each relay.

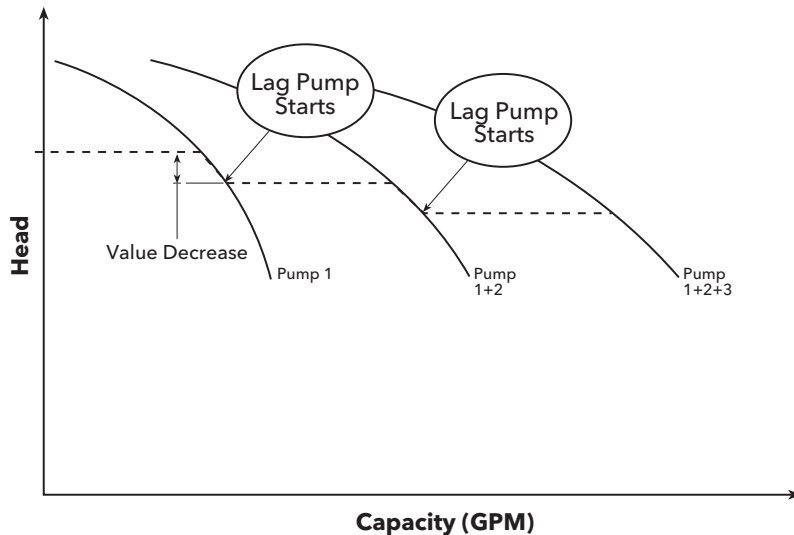

The figure shows Pump 1 when it cannot maintain the system pressure (value decrease). Next, Pump 1 + lag pump 2 will operate as a lead and lag system. If Pump 1 + 2 cannot maintain system flow, then lag # 2 pump will turn on, then you will have all three pumps ( 1 + 2 + 3 ) operating in the system. You can operate up to 3 slave pumps, with 1 Aquavar controlled pump.

**NOTE:** Each lag pump is controlled by the speed of the lead Aquavar pump, system pressure drop (value decrease), and a delay time in seconds. Do not set the pressure drop too close to operating system pressure, or pump cycling will occur!

# PROGRAMMING

## MultiPump - Slave Pump Control









### Lead vs. Lag

The Aquavar controlled pump will always be considered the "LEAD" pump, and start first in the system sequence. The constant speed pumps will always be the "SLAVE" or "LAG" pumps in the system. When the Aquavar controlled pump, starts to "run out" or cannot meet the system demand, then the first relay output will actuate based on a programmed pressure and time delay. The Aquavar CPC has up to three contacts that can be used for "SLAVE" operation.

### Wiring/ Connection

The relays used for the SLAVE pump control are dry relay contacts, rated for a MAXIMUM 250 VAC or 30VDC, 2 Amps free from inductivity. Minimum is 500 mW (12V, 10mA). Refer to diagram below, or in APPENDIX section.

Each relay will be wired to a voltage starter DO NOT EXCEED 250 VOLTS AC through each relay. Each relay is designed for control power only. It is up to the operator to provide necessary starters, overloads or fuses for each SLAVE pump motor control. Always follow your local codes or National codes and have a certified electrician perform the necessary wiring.

Relay Outputs	19	RO1C		Relay output 1, programmable. Default = Run power to drive Maximum: 250 VAC / 30 VDC, 2 A Minimum: 500 mW (12 V, 10 mA)
	20	RO1A		
	21	RO1B		
	22	RO2C		Relay output 2, programmable. Default = Ready pump is running Maximum: 250 VAC / 30 VDC, 2 A Minimum: 500 mW (12 V, 10 mA)
	23	RO2A		
	24	RO2B		
	25	RO3C		Relay output 3, programmable. Default = not used Maximum: 250 VAC / 30 VDC, 2 A Minimum: 500 mW (12 V, 10 mA)
	26	RO3A		
	27	RO3B		

**NOTE:** Normally Closed (NC) = R01A, R02A, R03A  
Common Connection (CC) = R01C, R02C, R03C  
Normally Open (NO) = R01B, R02B, R03B

### SLAVE Pump Sizing/ Piping

It is recommended that each slave pump be sized the same and with the same performance curve. All necessary check valves, ball valves, or gate valves should be installed in the system to limit or "choke" each SLAVE pump discharge in order to maintain proper head conditions and to prevent pressure oscillations or system "hunting". Follow all recommended Hydraulic Institute standards for piping size and pipe layout.

# PROGRAMMING

## MultiPump - Slave Pump Control

### Programming Steps

Default settings for each relay are set for NOT USED. Therefore, the operator will have to access the programming, and go to GROUP 18 "RELAY OUTPUTS" and set each relay to START SLAVE. **(SEE BELOW FOR DETAILED PROGRAMMING STEPS.)** Each relay is labeled (R01, R02, R03) and can be programmed to respond based on a drop in system pressure and delay time in seconds. Therefore, you can control the relay when the system pressure starts to drop, and you allow a certain time delay in seconds to respond. When the demand stops, each LAG pump will stop after a time delay, and operation will return solely to the Aquavar controlled pump.

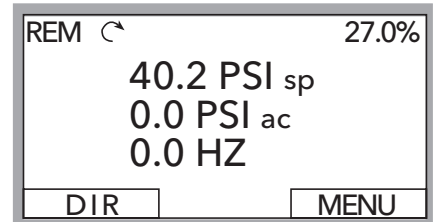

1. Access the main menu on the keypad. Press the MENU key once and the display will show (PARAMETERS, WIZARDS, CHANGED PAR). Using the arrow keys, highlight the "parameters" option, then press the "ENTER" key.



2. Once the parameters option has been chosen, the parameter groups will be displayed. Each group will be numbered (see parameter groups list on page 50 for detailed information). Use the arrow keys to highlight the parameter group 10, "LOCKS/PASSWORDS", then press the SEL key.

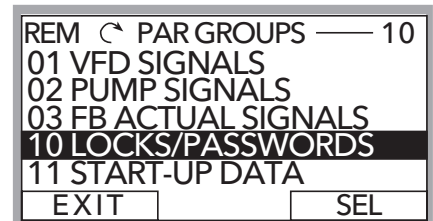

3. Use the arrow keys to highlight group 1002 "PASSCODE", then press the EDIT key. Enter your factory password number (Default is 66). Press the save key.

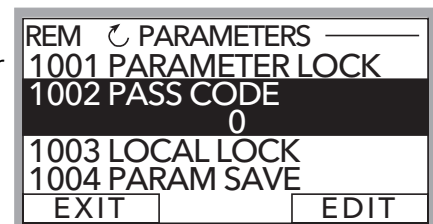

4. Use up arrow to group 1001 "PARAMETER LOCK", then press the EDIT key. Next, use the up arrow to select "OPEN", then press the SAVE key. This group should appear as "OPEN", if it does not you have entered the pass code incorrectly, or it has changed. Contact your local CentriPro representative for the master code. Once your group 1001 is showing "OPEN", you can access the entire pump and drive parameters in the Aquavar.

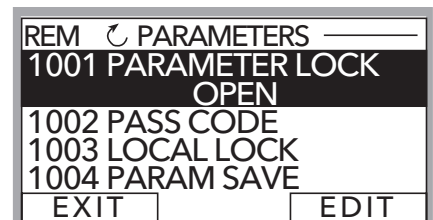

# PROGRAMMING

## MultiPump - Slave Pump Control

5. After the SAVE key is pressed in the above group, press the EXIT key, then the down arrow to highlight the group 11 "START UP DATA", then Press the SEL key once. Using the arrows, highlight 1102 "APPLIC MACRO", then press the EDIT key. Using the UP arrow, highlight "CONSTANT SLV" option, then press SAVE key.

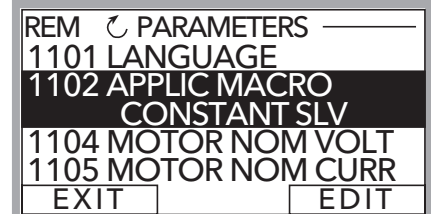
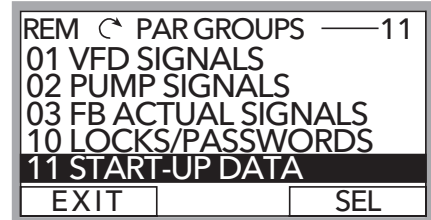

6. Use down arrow until group parameter 1104 "MOTOR NOM VOLTAGE" is highlighted, then press EDIT. Use the arrows to enter your motors nameplate voltage, then press the SAVE key.

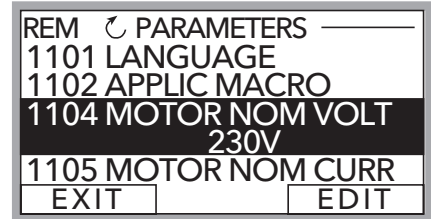

7. Use the down arrow until group parameter 1105 "MOTOR NOM CURRENT" is highlighted, then press EDIT. Using the arrows, enter your motor's maximum allowed amp draw at speed, or Service Factor Amps. **NOTE: Enter motors service factor from nameplate or motor manual.** Once you have entered the amps, press the SAVE key.

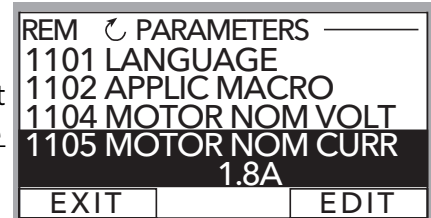

8. Use down arrow until you highlight group parameter 1107 "MOTOR NOM RPM", then press the EDIT key. Use arrows to enter the RPM from the motor nameplate, default is 3450 RPM. Press the SAVE key to store setting.

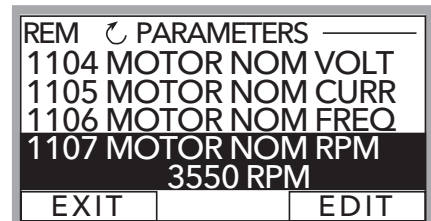

9. Use down arrow until you highlight group parameter 1108 "MOTOR NOM POW", then press the EDIT key. Use arrows to enter the otors Horsepower rating from nameplate, then press the SAVE key.

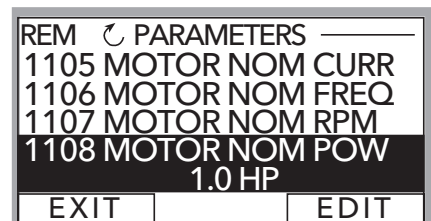

# PROGRAMMING

## MultiPump - Slave Pump Control

10. After saving your motor horsepower, press the EXIT key. Use the down arrow until you highlight the group 15 "XDUCER VARIABLES", then press EDIT.

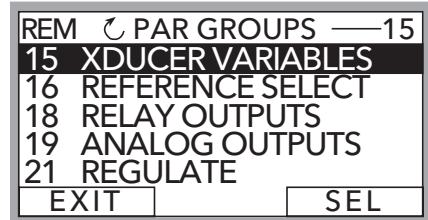

11. Press the down arrow until parameter 1502 TRANSDUCER MAX is highlighted, then press EDIT. Default pressure transducer setting is 300 psi. Adjust this based on your maximum rating for a new transducer. **NOTE:** CentriPro provides a 0 -300 psi transducer as standard. Select the appropriate range, then press SAVE. If no changes are necessary, press CANCEL.

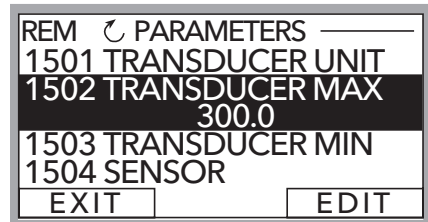

12. Use the down arrow to highlight 1503 "TRANSDUCER MIN" 0.0, then press EDIT. Default should be 0 psi. Press CANCEL to advance to the next step. If this group needs to be changed based on another type of transducer value, press SAVE to store.

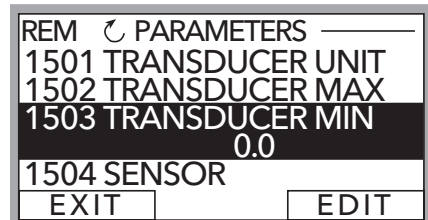

13. Use the down arrow to highlight 1506 "SENSOR MIN", then press EDIT. Use the up arrow until the "TUNE" value is displayed, press the SAVE key. This provides the transducer a tuned value of 0 (ZERO) psi. **NOTE: Make sure that your transducer is wired to the Aquavar but free from any pressure in the system.** The transducer must be exposed to 0 psi when this step is performed. Press the SAVE key to tune your transducer.

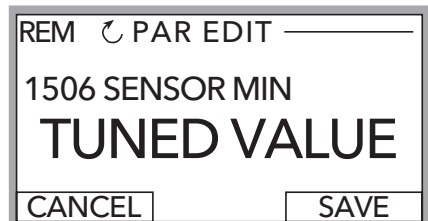
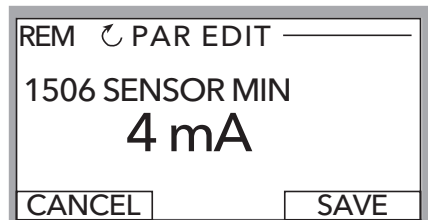
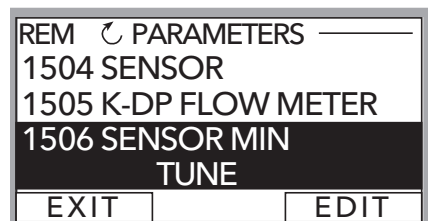

# PROGRAMMING

## MultiPump - Slave Pump Control

14. Once you have saved the parameter 1506, press the EXIT key. Use down arrow until you highlight parameter group 18 "RELAY OUTPUTS". Then press the SEL key.

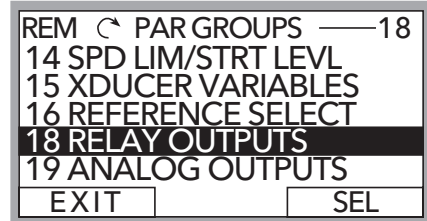

15. After above step, you should have parameter 1801 "RELAY OUTPUT 1" highlighted. Press the EDIT once. Uses the up arrow to highlight "START SLV", then press SAVE.

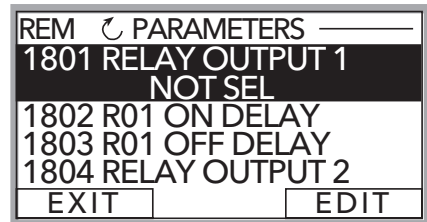

16. Use the down arrow to highlight parameter 1802 "RO 1 ON DELAY", then press EDIT. Use the UP arrow to set your time delay to TURN ON RELAY 1 in seconds. Then press the SAVE key. **NOTE: You may have to adjust this time delay based on your system.**

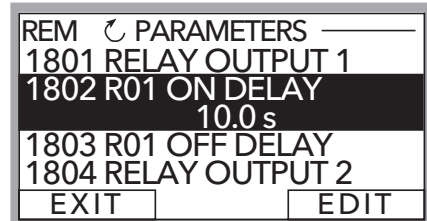

17. Once parameter 1802 has been saved, use the DOWN arrow to highlight parameter "1803 RO 1 OFF DELAY", then press the EDIT key. Use the UP arrow to select the OFF DELAY for relay 1 in seconds. Press the SAVE key. This will allow a timed delay when relay 1 turns off the first slave pump.

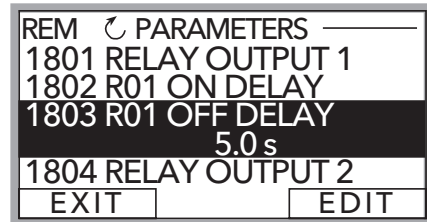

18. If you do not require other SLAVE relays, then proceed to the next step MULTIPUMP CONTROL. If more relays are required, repeat steps above for RELAY 2 and RELAY 3, parameters 1804, 1805, 1806, 1807, 1808.

19. Once you have saved your last relay output, press the EXIT key once. Use the down arrow until you highlight parameter group 22 "MULTIPUMP CTRL", then press SEL key.

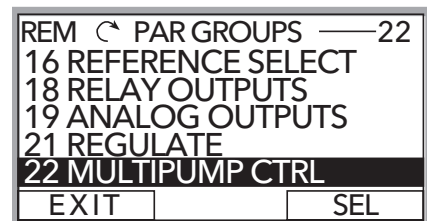

20. After above step, highlight parameter 2201 VALUE DECREASE, then press EDIT. Use arrows to program the required pressure drop allowed by the Aquavar pump, before the first slave pump turns on. Press the SAVE key.

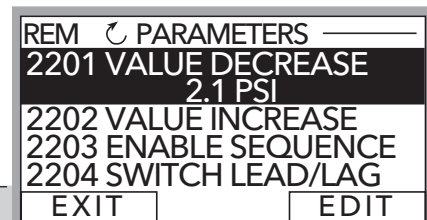

**NOTE:** Keep this pressure low enough from the Aquavar pressure setting and adjust your relay ON TIME DELAY to PREVENT PUMP "CYCLING"!



# PROGRAMMING

## MultiPump - Slave Pump Control

21. Once previous step has been saved, use the Down Arrow and highlight parameter "2203 ENABLE SEQUENCE", then press EDIT. Using the up or down arrow, enter the frequency in Hertz (HZ) that you wish the SLAVE pump will turn on once the lead pump reaches this speed. Default is set for 59 HZ and is typical for 60HZ systems. If you change this setting, press the SAVE key. If no changes are required, then press the EXIT key.

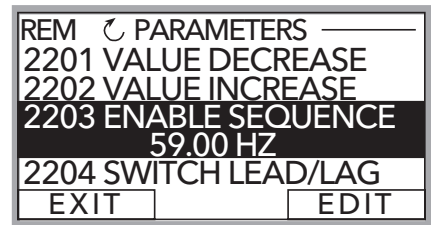

22. Group 2205 - Enter frequency for slave pump to be turned off.

23. Final step is to enter your required pressure in the system. After above programming has been completed, press the EXIT key two (2) or three (3) times, until you arrive back to the first control display screen. (SEE DIAGRAM) Then press the UP or DOWN arrow to select the required system pressure for your Aquavar controlled pump. Once pressure has been selected, press the green START key on the keypad.

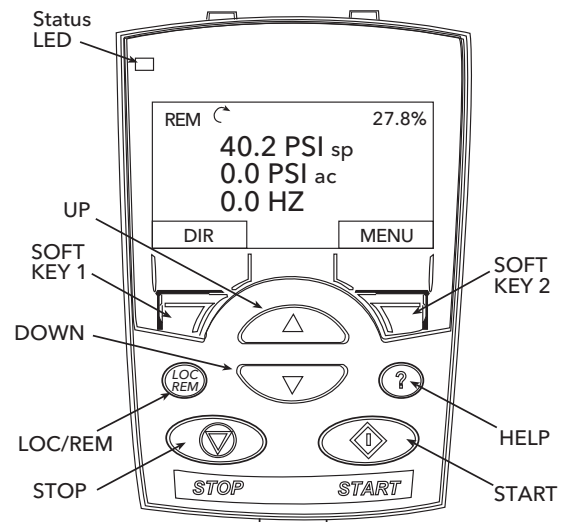

24. **Optional Step:** To lock out access to the control panel (keypad), refer to page 104. This will prevent unauthorized users from changing programming.

**NOTE:** If an error or fault occurs, refer to the faults/alarms section of this manual, page 115. When troubleshooting an Aquavar system, always break down into the following components:

1. **Aquavar programming** – check default settings recommended for single pump, multi-pump, slave pump etc.
2. **Electrical supply/ motor/ wiring/grounding** – check your supply voltage, motor wiring, transducer wiring, and grounding.
3. **Mechanical/Pump/ Rotation** – check your pump rotation, rubbing or other mechanical problems. Pump " run out".
4. **Hydraulic System/ Piping** – check to ensure proper suction and ischarge piping layout, proper NPSHa, air entrainment, vortex, friction loss, system curve compensation etc.
5. **Environment** – protect from high temperatures, direct sun, freezing temperatures, high altitude, dust, vibration, lack of air flow.



# FEATURES

## Analog Outputs

The Aquavar CPC has two 4-20 mA analog outputs as standard. These outputs may be configured by the user to output from a selection of nine actual pump signals. Parameter group 19 is used to configure these outputs. Analog Outputs are found on X1 Terminal Block, # 2 and # 5 pins. Reference the terminal block diagram on **pages 24-31** for detailed wiring connections.

Parameter	Name	Value/Range	Note(s)
19.01	AO 1 Content Sel	Not SEL (default) MOTOR FREQUENCY MOTOR CURRENT MOTOR POWER MOTOR PROC VAR MOTOR ENERGY SAVNGS	CONNECTS an ANALOG SIGNAL TO THE ANALOG OUTPUT. RANGE IS 0-20mA input.
19.06	AO 2 Content Sel	Not SEL (default) MOTOR FREQUENCY MOTOR CURRENT MOTOR POWER MOTOR PROC VAR MOTOR ENERGY SAVNGS	CONNECTS an ANALOG SIGNAL TO THE ANALOG OUTPUT. RANGE IS 0 - 20mA input. <b>THIS IS THE DEFAULT PRESSURE TRANSDUCER INPUT. 4 - 20Ma.</b>
21.01	REGULATION MODE	NORMAL (DEFAULT) INVERSE	SELECTS THE TYPE OF AQUAVAR CONTROL AS THE ANALOG SIGNAL RISES OR FALLS. SET TO INVERSE FOR DECREASED MOTOR SPEED BASED ON SUCTION LEVEL TRANSDUCER.
26.03	SAVINGS SCALE	0-65535 Default - 10,000	If ENERGY SAVNG is selected as an output, this parameter must be set to scale the signal. 4 mA = \$0.00 and 20 mA equals this amount. For example 20 mA = \$10,000.

## Auto Restart

The Aquavar drive can be configured to start automatically following a power failure. Changing the value to ON will enable auto-restart. Selecting OFF disables the auto-restart. AUTO RESTART is also used with ERROR RESET for automatic restarts following a shutdown due to a pump fault. AUTO RESTART will also restart the pump once a secondary protection fault is reset.

Parameter	Name	Value/Range	Note(s)
12.02	AUTO RESTART	OFF ON (DEFAULT)	When this is set to "ON", the Aquavar will automatically re-start after a power failure or fault reset.
25.04	AR OVER- CURRENT	ENABLE	Allows the drive to restart after a motor overcurrent error.
25.05	AR OVER- VOLTAGE	ENABLE	Allows the drive to restart after an INPUT OVERVOLTAGE error.
25.06	AR UNDER- VOLTAGE	ENABLE	Allows the drive to restart after an INPUT UNDERVOLTAGE error.
25.07	AR AI < MIN	ENABLE	Allows the drive to restart after a transducer or analog signal loss.

# FEATURES

## Energy Savings Information [Group 26]

Aquavar can calculate the energy savings as compared to a constant speed pump application. To enable this function to perform properly, local energy costs and comparative application information must be entered.

Enter the local energy cost in \$ (local currency) per kWh into parameter 26.01(\$/KWhr) and then enter the nominal power rating of a comparable fixed speed unit into parameter 26.02 (baseline power). To find this, look at the fixed speed pump performance curve and enter the power for the rated operating point or maximum Brake Horsepower for the specific pump/impeller combination.

*Example - If your power cost is \$0.06 per kWh, enter a value of .06 into parameter 26.01.*

Parameter	Name	Value/Range	Note(s)
26.01	\$/kWh	0-1.00	Default is zero.
26.02	BASELINE POWER	0-1000 HP	Default is zero.
26.03	SAVINGS SCALE	0...65535	Scales the analog output when energy savings is selected.
26.04	ENERGY SAVE METHOD	SAVINGS OP 1	Calculates energy savings with the Aquavar based on a fixed speed pump that turns ON and OFF when not required.
		SAVINGS OP 2	Calculates energy savings with the Aquavar based on a fixed speed pump that operates 24 hrs a day. Does not turn off.
26.05	ENERGY SAVE RESET	DISABLED (Default) RESET	Allows resetting of savings to zero.

One of the benefits of using Aquavar is its ability to automatically shut off the pump when not required. Parameter 26.04 SAVINGS OPTION #2 allows the savings of using Aquavar to be tracked during automatic shutdown. The OPTION # 2 will calculate according to a fixed speed unit that is designed to run continuously 24 hrs a day, 7 days a week.

**NOTE:** This is an estimated comparative data used for ideal situations, CentriPro cannot guarantee savings will be exactly as stated. Many system variables may increase or decrease estimated savings.

## Fieldbus Control

The Aquavar CPC may be integrated into BMS (Building Management Systems) or existing Distributive Control Systems (DCS) via optional Fieldbus control modules. The use of Fieldbus control modules allows selected Aquavar parameters and operating signals to be accessed and modified.

Fieldbus control modules are available in numerous communication protocols, including: DeviceNet, Modbus, Profibus.

Modbus® is the DEFAULT protocol for the Aquavar CPC.

With the control module installed (See INSTALLATION manual), set parameter 30.01 FIELDBUS to YES. This will open up parameter groups 90 D SET REC ADDR and 92 D SET TR ADDR. These parameter groups define the addresses and data sets that are exchanged between Aquavar and the DCS.

# FEATURES

Parameter	Name	Value/Range	Note(s)
30.01	COMM PROTOCOL SELECT	NOT SELECTED (Default)	No fieldbus communication
		STD MODBUS	Drive uses MODBUS protocol on the standard RS485 port. Protocol settings are in group 32.
		EXT FBA	The drive communicates with a fieldbus adapter module in option slot 2 of the drive. NOTE: When EXT. FBA is selected parameter group 31 is unlocked.

Any parameter changes that are made using a Fieldbus control system must be saved to the drive.

Parameter	Name	Value/Range	Note(s)
10.04	PARAMETER SAVE	DONE (Default) SAVE	Parameters that are manually entered through the keypad are automatically saved, only parameters entered through a Fieldbus connection must be saved. To save, select SAVE and press the ENTER key.

## Language

The Aquavar CPC system fully supports 3 languages; English(AM), French, and Spanish. English(AM) refers to American English and is the default language. Units of power are in HP.

Parameter	Name	Value/Range	Note(s)
11.01	LANGUAGE	ENGLISH (AM) ESPANOL FRANCAIS	ENGLISH (AM) is the default setting.

## Locking

The AQUAVAR CPC has three levels of control panel (keypad) locking; LOCAL LOCK, PARAMETER LOCK and SET POINT LOCK.

- **PARAMETER LOCK** - In parameter lock, parameters may be viewed, however they cannot be changed. Starting, Stopping, set point changes and drive fault resets may still be performed using the keypad. A valid password must be entered in parameter group 10.02.
- **LOCAL LOCK** - In local lock, starting and stopping, and setpoint changes are prevented. Resetting of drive faults is still possible and ON and OFF control.
- **SET POINT LOCK** - When in the "ON" position, the set-point cannot be changed from the control panel. This prevents unwanted changes to Aquavar settings.

To change the drive parameters, including 10.03 LOCAL LOCK, the parameter lock must be opened. To open the parameter lock, go to parameter 10.02 PASS CODE and scroll to the number 66 and press ENTER. Parameter 10.01 PARAMETER LOCK will read OPEN.

**NOTE:** If power to the drive is lost [power failure, disconnect, etc...] parameter 10.01 PARAMETER LOCK will automatically reset to LOCKED.

# FEATURES

Parameter	Name	Value/Range	Note(s)
10.01	PARAMETER	LOCKED (Default) OPEN	This parameter displays the status of the parameter lock and can be used to lock the parameters when necessary. To OPEN the parameter lock, use parameter 10.02.
10.02	PASS CODE	-Not Displayed-	Using the arrow keys, scroll to the number "66" and press enter. This will open the parameter lock. Note - The number entry will disappear once ENTER has been pressed.
10.03	LOCAL LOCK	OFF (Default) ON	This parameter disables local control of the drive (Start/Stop/setpoint changes).
10.06	SET POINT LOCK	OFF (Default) ON	This lock prevents the set point from being changed on the control panel. Must enter password first.



**WARNING!** It is not possible to stop the drive through the keypad with LOCAL LOCK set to ON.

- Use LOCAL LOCK only with a remote (external) stop/start method.
- Keypad must be set in REMOTE before enabling LOCAL LOCK.

## Minimum Speed Options

When the Aquavar CPC reaches the minimum speed that is set in parameter 14.02, it can be programmed to stay at that minimum speed indefinitely, or to shut-down after a time delay. This reaction applies to conditions where Aquavar is trying to regulate to a setpoint, when it faults due to a secondary protect condition, or there is little or no process demand.

If the parameter 14.03 CONFIG SPEED MIN is set to MINIMUM FREQ the drive will stay at minimum speed indefinitely, until the system demand increases, it is shutdown manually, or a fault occurs forcing it to shutdown. If it is operating at minimum speed due to a Secondary Protect fault, it will stay at minimum speed until the fault is reset.

If a Pump Protect condition exists and CONFIG SPEED MIN is set to MINIMUM FREQ, Aquavar will try to reset the fault while at minimum speed if parameter 12.02 AUTO RESTART is set to "ON" and parameter 24.06 ERROR RESET is set for the desired number of attempts. If the fault has not cleared after the selected number of resets has been attempted, the pump will be shut down. If parameter 24.06 ERROR RESET = 0, the pump will be shut down upon a Pump Protect fault.

If parameter 14.03 CONFIG SPEED MIN is set to ZERO "0" (DEFAULT), the drive will stop the pump for Pump Protect and Secondary Protect faults. The reaction to stop the pump when at minimum speed can be delayed for up to 1800 seconds by programming parameter 14.04 (Stp Delay Min Spd).

**For example, if the MINIMUM FREQ. is set for 35 HZ, and the Stp. Delay Min Spd is set for 5 seconds, the pump will ramp down to 35HZ and remain at that speed for 5 seconds, then turn off. This is dependent upon the demand decreasing in the system. Leaks will keep the pump running at slow speeds. Also check for properly seated check valves and bladder tank pressure.**



**WARNING!** It is not possible to manually set speed or frequency below the MINIMUM SPEED setting in parameter 14.02

# FEATURES

## Minimum Speed Options *(continued)*

Parameter	Name	Value/Range	Note(s)
14.03	CONFIG SPEED MIN	SPD=MINSPEED SPD=0 [default]	Selecting SPD=MINSPEED will result in the drive staying at minimum speed until it is manually shut-off, process demand increases, a secondary protection fault is cleared, or a pump protection fault forces it to shutdown. If SPD=0 is selected, the drive will stop.
14.04	STP DELAY MIN SPD	0-1800 sec 0 (default)	This parameter enables the drive to remain at minimum speed for a period (up to 1800 seconds) before shutting down.
14.05	RESTART VALUE	0.0-150% 0 (default)	If the drive is shutdown by CONFIG SPEED MIN (14.03) due to no system demand (pressure control and level control modes only) the drive will sleep until the process actual value drops below a set restart value (14.05) for longer than the restart delay (14.06). If operating in inverse mode (21.01) the drive will sleep until the process variable rises above the restart value. Wake-up level in % of setpoint value = 0 - 150%. Default is 0%. To disable the Restart Value function enter "0%".
14.06	RESTART DELAY	0-3600 Sec 0 (default)	This is the length of time the drive waits between starting the pump according to 1405 value.
12.02	AUTO RESTART	OFF (default) ON	This enables the drive to restart on its own following a power failure or ERROR RESET.
24.06	ERROR RESET	0 (Default) 1-9999	If the Aquavar unit faults on Pump Protection, this parameter will reset the fault up to the selected number of times before completely shutting off the drive.
24.07	RESET DELAY	0-250 seconds 60 seconds (Default)	The automatic reset of protection faults can be delayed. Default value is 60 seconds.

### Restart Value

Allows a pressure or value drop before the Aquavar starts to maintain system pressure. Units are in % of set value. (e.g. If set pressure is 100 PSI and 14.05 is set for 90%, then the Aquavar will wait until system pressure drops to 90 PSI before starting.)

### Priming Delay

This feature will override the PUMP PROTECT feature and is designed to allow self-priming pumps sufficient time to prime before the Aquavar Pump Protection logic becomes active. The delay period is applied only if the pump is being started from a zero-speed condition. Once the priming delay is complete, the PROTECTION DELAY (24.06) becomes active, if set.

Parameter	Name	Value/Range	Note(s)
14.07	PRIMING DELAY	0-6000 Seconds 0 (Default)	The priming delay time is added to the pump protection delay time.

**NOTE:** Do not set beyond normal priming time for specific pumps or damage may occur. Refer to pump manufacturer for maximum allowed priming times before shutdown.

# FEATURES

## Pump Protect Ctrl

This feature is designed to protect the pump from lack of available NPSH, loss of or low suction, pump run-out. This pump protection feature is exclusive to the Aquavar® and measures the discharge pressure of the pump via the transducer, and compares it with the minimum allowed system pressure as entered into parameter (2403) PROTECTION LIMIT. If this parameter is set, then a time delay will need to be set in number of seconds allowed to run at or below this limit, before shutting down on a fault.

Parameter	Name	Value/Range	Note(s)
24.02	PUMP PROTECT CTRL	Disabled (Default) WARN WARN & CTRL.	Provides no warning, warning or warning and then shut off.
24.03	PROTECTION LIMIT	0 - 6553.5	Actual value units.
24.04	PROTECTION DELAY	0 - 200 seconds	Provides a time delay for 24.03.

**NOTE:** It is recommended to set this pump protection according to suggested minimum allowed system requirements. (i.e. pump run-out limits)

## Regulation Mode

The regulation mode can either be NORMAL or INVERSE. The **default** and more common selection is NORMAL, where the Aquavar software anticipates an increase in system pressure, and will decrease speed of the pump based on a rising system pressure. If the regulation mode is set to INVERSE, the process condition is expected to increase with a decrease in pump speed.

Parameter	Name	Value/Range	Note(s)
21.01	REGULATION MODE	NORMAL (Default) INVERSE	Inverse is normally used for control of suction side systems.

**EXAMPLE** - If an Aquavar unit is trying to control the level in a suction-side tank or sump, the regulation mode would be set to INVERSE. As the level in the sump increased, Aquavar would respond by increasing pump speed to maintain a constant level.

## Relay Outputs

The AQUAVAR CPC has three relay outputs that are configurable for different operating and fault conditions. Relays will revert to original states once warnings or faults are reset or cleared.

Comment(s)	
Maximum Contact Voltage	30 VDC, 250 VAC
Maximum Continuous Current	2 A RMS

Refer to the terminal layout diagram for RELAY OUTPUT specifications.  
Maximum Contact current/ power = 6A, 30 VDC, 1500 VA, 250 VAC

# FEATURES

Parameter	Name	Value/Range	Note(s)
18.01	RELAY R0 OUTPUT	NOT USED	Default for RO1
18.04	RELAY R02 OUTPUT	RUNNING	Default for RO2
18.07	RELAY R03	READY OUTPUT VFD FAULT SECND PRTECT A PUMP PROTECT START SLAVE STAND BY	Default for RO3  Secondary Protect A activation. Pump protection activation. Used with multi-pump macro only.

**NOTE:** When using relay outputs to activate constant speed pumps in a multi-pump application, the slave pumps 1, 2 and 3 should utilize relay outputs RO1, RO2, and RO3 accordingly (Slave 1 → RO1). Sequence logic is affected by these selections.

## Restart Options

Parameter 14.05 – See MINIMUM SPEED OPTIONS

## Low Water (Suction) Protection

The Aquavar provides protection from “dry-run” conditons in pressure, level, temperature and speed control modes. This feature may also be used to provide inter-lock capabilities. In these cases, additional system condition inputs (e.g. level switch, pressure switch, flow switch, etc...) are used to alert Aquavar of conditions that require protection of the pump.

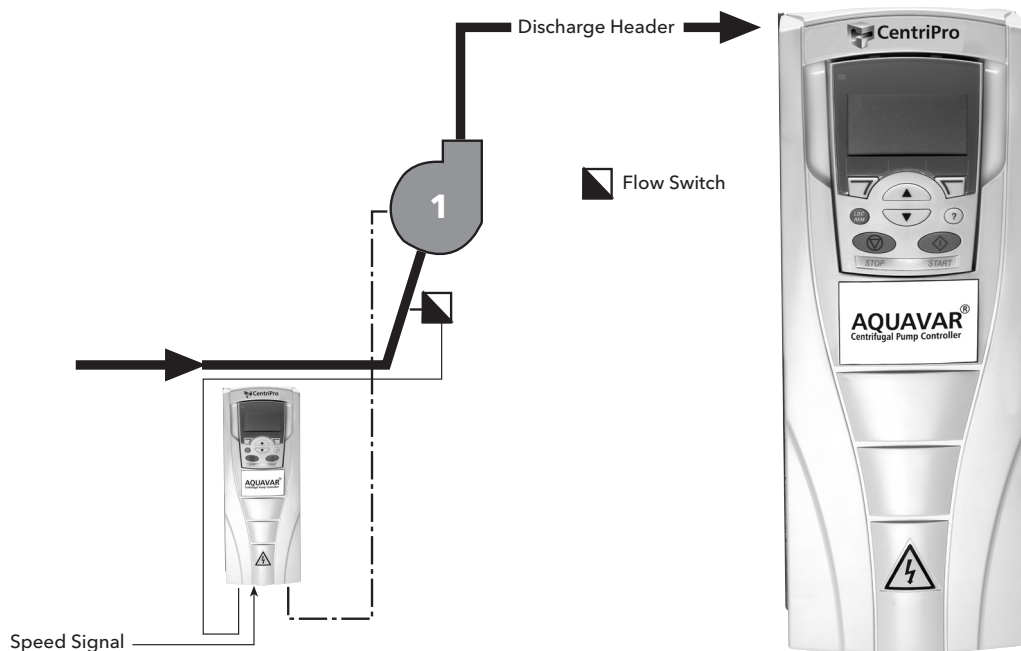

Once wired, parameter 24.05 LOW WATER must be set to WARNING or WARN AND CONTROL. Digital Input 2 (DI 2), terminal # 14 on the X1 terminal board. If this contact is OPEN, the response being:

- 1. WARN & CONTROL** - In this response, Aquavar will issue a warning and then either shut down or reduce speed depending on your settings. At this point the pump will behave similar to the description in MINIMUM SPEED. Alarm & Control is the recommended setting.



# FEATURES

**2. WARNING ONLY** - In this response, Aquavar will simply issue an alarm/warning displayed on the keypad screen, but continues to operate.

**NOTE:** The WARNING ONLY mode may result in damage to the pump if a low water condition occurs. It is recommended to set this for WARN & CONTROL.

## Keypad Failure

In the event of a keypad failure, Aquavar has been configured to fault and shut down the controller. This functionality can be disabled, or configured to result in a drive fault.

Parameter	Name	Value/Range	Note(s)
24.01	KEYPAD FAILURE	DISABLED (default) FAULT	Fault message - "PANEL LOSS"

## Set Points, Dual

The Aquavar can alternate between two fixed set points or one fixed point and a variable set point. The alternating between set points may be accomplished using a digital switch or through a Fieldbus command.

Parameter	Name	Value/Range	Note(s)
16.01	SP1/SP2 SELECT	SETP 1 [Default] DI4 FIELDDBUS	This parameter defines the source that toggles the Aquavar unit between Set Point 1 or Set Point 2. <ul style="list-style-type: none"> <li>• SET POINT 1 (Default) indicates that only set point 1 is being used.</li> <li>• DI4 is a digital input where "0" (Open) selects Set Point 1 and "1" (Closed) selects Set Point 2.</li> </ul>
16.02	SET POINT 1 SEL	KEYPAD (Default) AI 1 FIELDDBUS	This selects where the value for Set Point-1 or 2 is coming from. <ul style="list-style-type: none"> <li>• KEYPAD - a number [e.g. 100] will be manually entered via the keypad. Selecting ANALOG INPUT will require entry of parameters 16.03-16.04.</li> </ul>
16.03	SET POINT 2 SEL	KEYPAD (Default) ANALOG INPUT FIELDDBUS	This selects where the value for Set Point-1 or 2 is coming from. <ul style="list-style-type: none"> <li>• KEYPAD - a number [e.g. 100] will be manually entered via the keypad. Selecting ANALOG INPUT will require entry of parameters 16.03-16.04.</li> </ul>
22.08	SET POINT 2 SOURCE	OFF, 1...4	Must select source.

**EXAMPLE for 16.02 and 16.03** - An irrigation system requires 110 psi for watering all zones, then during the daytime normal water pressure is set for 60 psi.



# FEATURES

Parameter	Value	Notes
16.01	DI4	A switch would be wired into DI4 and the DCOM on the X1 terminal to toggle between set point 1 and set point 2.
16.02	KEYPAD	The setpoint would be manually entered using the Aquavar keypad. When the switch [DI4] is set to "0" (Open), the set point would be entered as "110 psi" using the keypad "REF" button.
16.03	KEYPAD	The set point would be manually entered using the Aquavar keypad. When the switch [DI4] is set to "1" (Closed), the set point would be entered as "60 psi" using the keypad "REF" button.



**WARNING!** Parameter 16.01, 16.02 and 16.05 can only be changed when the motor is not running. Most parameters require you to stop the pump, before programming.

## System Curve Compensation

The AQUAVAR CPC system can automatically compensate for system friction losses due to increased flow in single pump operation or multi-pump backup modes. Tables are available in most pump catalogs to assist in determining the amount of friction loss that can be expected for various pipe sizes and flow rates on simple systems. As flow increases, velocity increases causing friction loss through piping and various fixtures. Normally this would provide a loss in flow or overall pressure to the system. With the Aquavar you can compensate for this friction loss!

The diagram below illustrates a typical system curve in relation to pump speed.

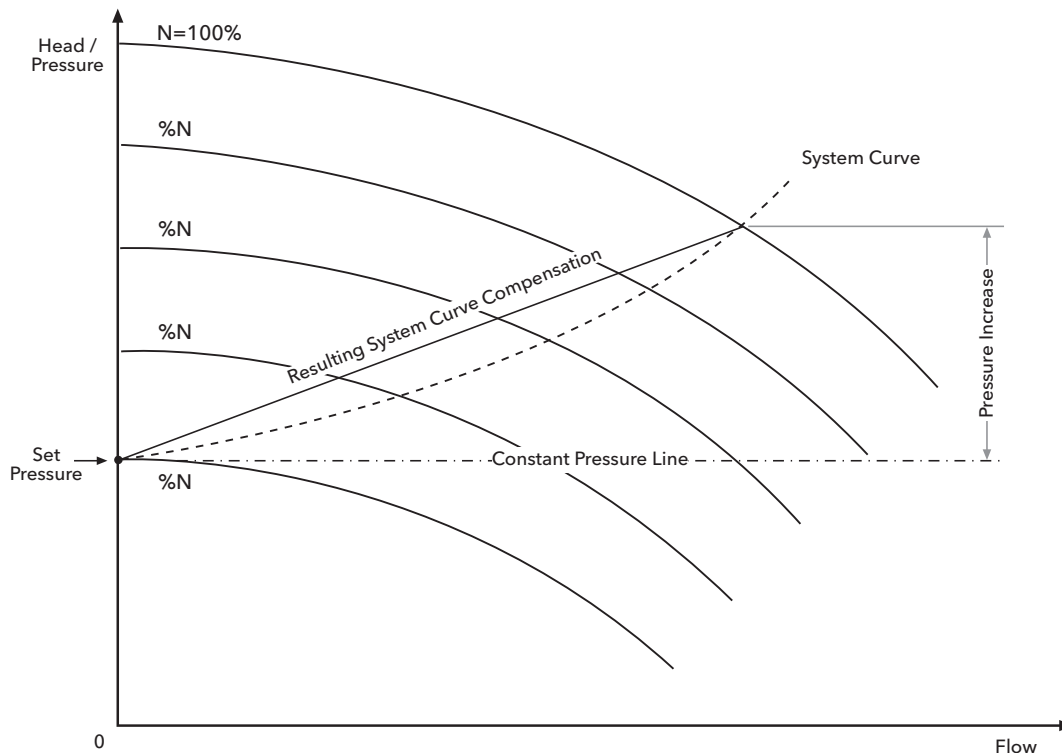

In this case the system pressure set point is shown at shutoff ( 0 flow) and the increase in setpoint pressure is shown for increasing flow. **EXAMPLE** - If the set point is 150 Ft [65 PSIG @ 1.0 SG] and the system resistance increase 10 Ft at the maximum flow rate, or roughly 7% of the set point, parameter 21.08 would be set as "7".

# FEATURES

Parameter	Name	Value/Range	Note(s)
21.02	PRESS INCR SPEED	0- 60 HZ 20 HZ (Default)	This is the frequency at which system curve compensation begins. At speeds below this, no compensation for increased resistance is made.
21.03	PRESS INCR 0.0 %	0-100% 0% (Default)	This is the amount that Aquavar will have increased the set point at maximum speed.

## Test Run

The TEST RUN capability allows the Aquavar system to run periodically if it has been inactive. The most common circumstance for which Test Run would be applied is when a standby pump is infrequently used; the test run would allow lubrication of bearings and help verify if the unit is ready for operation. The TEST RUN DELAY sets the interval that automatic test runs will occur at.

Test runs are factory programmed for 20 seconds. This duration cannot be changed. If Automatic test run is selected, the test run is at 50% of maximum speed.

**NOTE:** Once manual test is selected and the test is complete, parameter 12.03 will return to NOT SEL.

Parameter	Name	Value/Range	Note(s)
12.02	AUTO RESTART	OFF (Default) ON	Must be set to ON for test run function to operate.
12.03	TEST RUN	NOT SEL (default) AUTOMATIC MANUAL	
12.04	TEST SPEED % (FL)	0-100% 50% (Default)	The speed, as a percent of maximum speed, which the test run will occur at if MANUAL is selected.
12.05	TEST RUN DELAY	0-3600 hours 1000 Hrs (Default)	This is the period of pump inactivity before the test run will begin, based on power up time.

## Tuning, System Pressure

If the pump appears to oscillate in speed [e.g. Hunting], cannot maintain a uniform set point, or shuts off too quickly or too slowly, the ramp rates and regulation window settings may need to be modified, or adjustments.

When an operating mode is selected [i.e. Flow, Pressure, Level, etc...], Aquavar engages factory default settings for the rate that the drive adjusts at to meet the set point demand. In most cases these settings will not require adjustment. The most common exceptions are with process instruments with slow response times [e.g. insertion type flowmeter<sup>1</sup>], or in temperature/level control applications, where variables such as tank size is unknown. HVAC Systems with flow meters may require adjustment as well.

When the Aquavar system is adjusting speed to meet the set-point demand, it does so using a fast rate and a slow rate. As shown in the figure below, the 2-point control algorithm uses four ramp rates; fast acceleration, fast deceleration, slow acceleration, and slow deceleration. Aquavar characterizes these rates in terms of seconds to meet the set point hysteresis window maximum value (described later).

**NOTE:** In speed control mode, there is only fast acceleration and fast deceleration [R1, R2].

<sup>1</sup>An insertion-type flowmeter uses a magnetic flux/Coriolis effect to measure fluid flow. This should not be confused with magnet flow meters or differential pressure flow meters.

# FEATURES

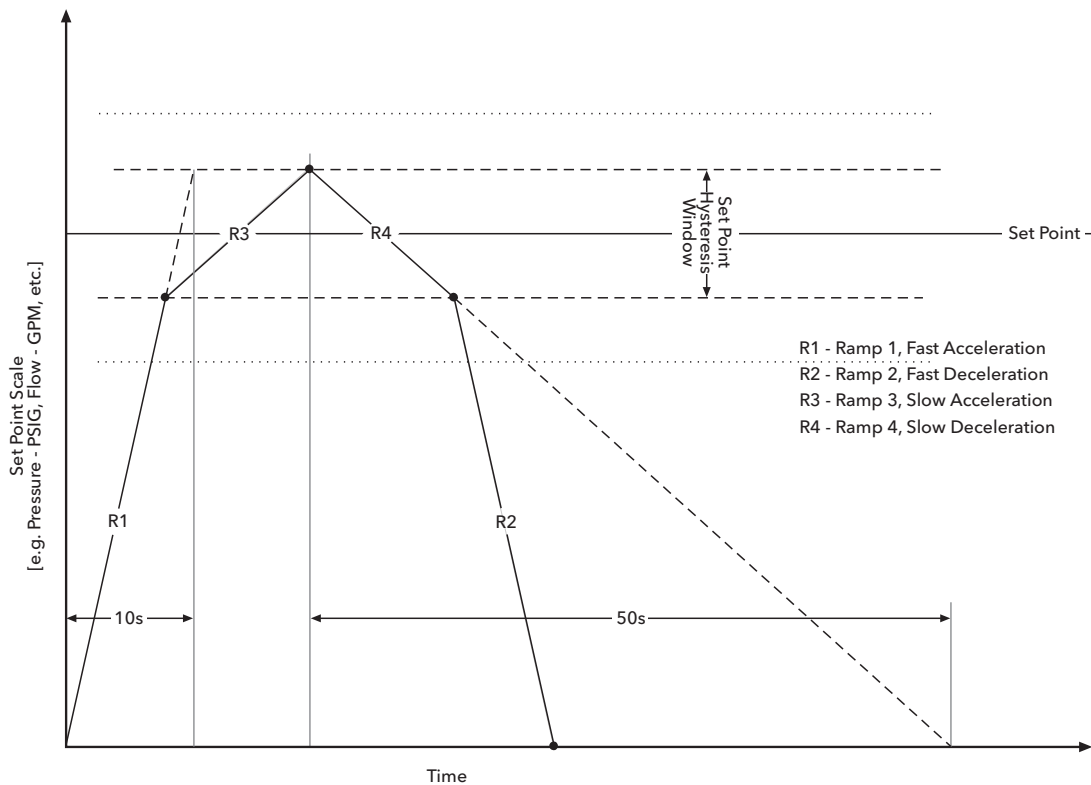

## Window Setting (Reg Window)

Aquavar controls the set-point within a defined window. This window, called the Regulation Window [*Parameter 13.06 REG WINDOW*] is automatically set based upon the operating modes and instrument type selected during programming. Values may be adjusted in parameter 13.06.

**EXAMPLE:** if the Aquavar unit was in pressure control with the set point at 100 psig, the regulation window would be factory preset at 8% of the set point. This would result in an 8 PSIG window; 4 PSIG above the set point and 4 PSIG below the set point.

Parameter	Name	Value/Range	Note(s)
13.06	REG WINDOW	0-100%	Constant Pressure = 8% Flow [Direct] = 30%

Suggested settings are above in the notes. Sometimes the REGULATION WINDOW will have to be adjusted to smooth out the system pressure. Default setting is 8%.

**NOTE:** If the system pressure drops below or goes above the hysteresis limits (DASHED lines), then the Aquavar control software will adjust the speed with the fast ramps. This would occur if you have a rapid demand of water in your system. Normally it takes a few seconds to level off.

# FEATURES

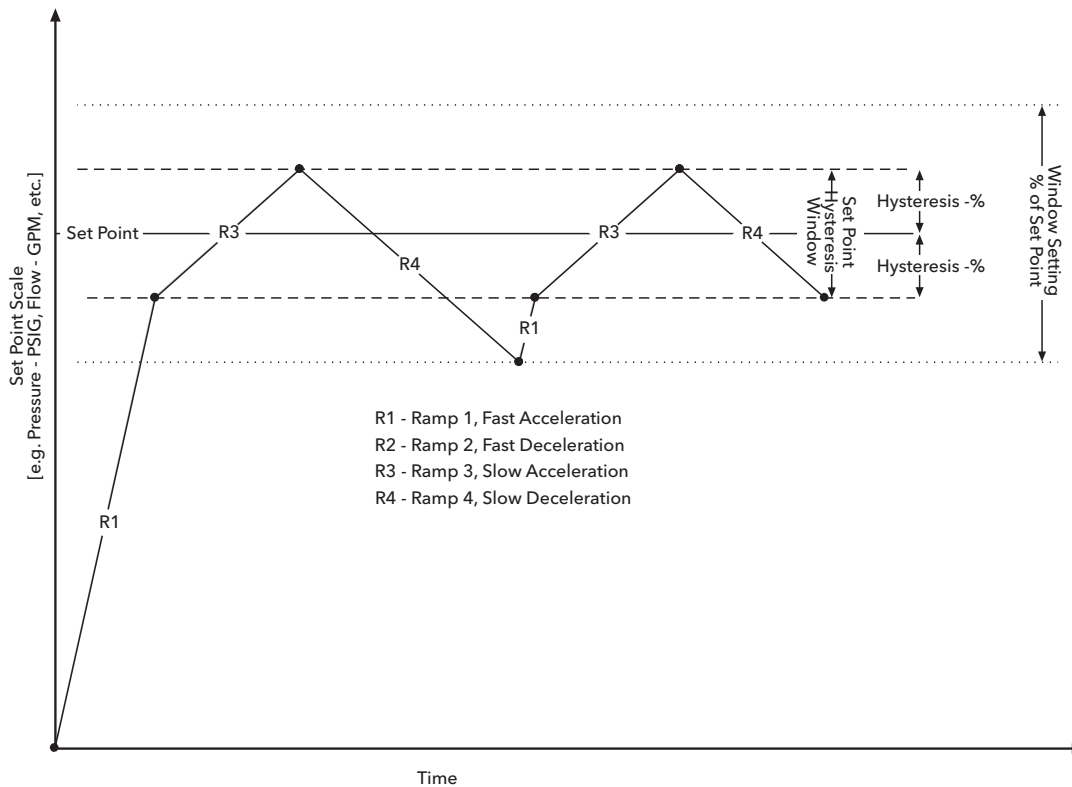

## RAMP HYSTERESIS

Ramp hysteresis is the point at which the Aquavar controller changes over from the fast ramp to the slow ramp. Default values of Ramp Hysteresis are in % of the regulation window. The values for RAMP HYSTERESIS are automatically selected based upon the control mode selection made during programming.

**EXAMPLE:** Using the same example above, the Regulation Window was 8 psig. An 80% ramp hysteresis would be 3.2 PSIG. Note from the graph, this is 1.6 PSIG on the upper half of the regulation window, and 1.6 PSIG on the lower half of the regulation window.

Parameter	Name	Value/Range	Note(s)
13.05	RAMP HYSTERESIS	0-100%	Pressure = 80% Flow [Direct] = 5%

As the figure shows, Aquavar attempts to keep the actual process reading within the Setpoint Hysteresis Window using the slow acceleration and deceleration ramp rates. When the process reading exceeds this window, it will compensate using the fast acceleration or deceleration ramp rates.

## Adjusting Ramp Rates

**Ramp 1 - Fast Acceleration:** This ramp is the fast run up time used when the pump first starts and is trying to reach the setpoint. A setting too fast may overshoot the set-point, while a setting too slow may cause the drive to respond too slowly to set point changes. **NOTE: FOR AQUAVAR UNITS ABOVE 10 HP, SET RAMP 1 AND RAMP 2 TO AT LEAST 8 - 10 SECONDS.**

Parameter	Name	Value/Range	Note(s)
13.01	RAMP 1 FAST ACCEL	0-1800s	Pressure default = 5 seconds Level, Temperature default = 20 seconds

# FEATURES

**Ramp 2 - Fast Deceleration:** This ramp is the fast run down time used when the pump is shutting down. If the setting R2 setting is too fast, the pump may oscillate, or “hunt” while it tries to attain the set point. If it is too slow, the actual process value may rise well above the set point. **NOTE: AQUAVAR UNITS ABOVE 10 HP, RAMP 1 AND RAMP 2 SHOULD BE SET FOR AT LEAST 8 - 10 SECONDS.**

**NOTE:** Air in the pump system may cause a condition that looks like oscillation or hunting. Make sure all the air is purged from the system before trying to change the Ramp 2 setting.

Parameter	Name	Value/Range	Note(s)
13.02	RAMP 2 FAST DECEL	0-1800s	Pressure default = 5 sec Level, Temperature default = 20 seconds

**Ramp 3, Slow Acceleration:** This ramp is the slow run up time used when the pump is operating within its setpoint window. If the R3 setting is too slow, pressure or flow may be slow to respond to the set point as demand varies. A setting too fast may lead to oscillation.

Parameter	Name	Value/Range	Note(s)
13.03	RAMP 3 SLOW ACCEL	0-1800s	Pressure default = 60 seconds Flow [magnetic flow meter] default = 50 sec Level, Temperature default = 200 seconds

**Ramp 4, Slow Deceleration:** This ramp is the slow run down time used when the pump is operating within its set point window. If the R4 setting is too slow, it will lead to oscillation. A setting too fast may delay the motor shut-down when demand is reduced.

Parameter	Name	Value/Range	Note(s)
13.04	RAMP 4 SLOW DECEL	0-1800s	Pressure default = 60 seconds Flow [magnetic flow meter] default = 50 sec Level, Temperature default = 200 seconds

# FAULTS/ALARMS



**Warning!** Do not attempt any measurement, parts replacement or other service procedure not described in this manual. Such action will void the warranty, may endanger correct operation, and increase downtime and expense.



**Warning!** All electrical installation and maintenance work described in this chapter should only be undertaken by qualified service personnel. The Safety instructions on the first pages of this manual must be followed.

## Diagnostic Displays

The drive detects error situations and reports them using:

- The green and red LED on the body of the drive.
- The status LED on the control panel (if a control panel is attached to the drive).
- The control panel display (if a control panel is attached to the drive).
- The Fault Word and Alarm Word parameter bits (parameters 0310 to 0311).  
See "Group 03: FB Status Words" on page 50 for the bit definitions.

The form of the display depends on the severity of the error. You can specify the severity for many errors by directing the drive to:

- Ignore the error situation.
- Report the situation as an alarm.
- Report the situation as a fault.

### Red - Faults

The drive signals that it has detected a severe error, or fault, by:

- Enabling the red LED on the drive (LED is either steady on or blinking).
- Setting an appropriate bit in a Fault Word parameter (0305 to 0307).
- Overriding the control panel display with the display of a fault code.
- Stopping the motor (if it was on).

The fault code on the control panel display is temporary. Pressing any of the following buttons removes the fault message: MENU, ENTER, UP button or DOWN button. The message reappears after a few seconds if the control panel is not touched and the fault is still active.

### Flashing Green - Alarms

For less severe errors, called alarms, the diagnostic display is advisory. For these situations, the drive is simply reporting that it had detected something "unusual."

The drive signals that it has detected an alarm, by:

- Flashing the green LED on the drive - does not apply to alarms that arise from control panel operation errors (Alarms 1 to 7).
- Setting an appropriate bit in an Alarm Word parameter (0308 or 0309).  
See "Group 03: FB Status Words" on page 50 for the bit definitions.
- Overriding the control panel display with the display of an alarm code and/or name.

The alarm messages disappears from the control panel display if/when any of the following are pressed on the control panel: MENU, ENTER, UP button, or DOWN button.

# FAULTS/ALARMS

## Correcting Faults

The recommended corrective action for faults is:

- Use the “Fault Listing” table below to find and address the root cause of the problem.
- Reset the drive. See “Fault Resetting” on page 119.

\* **Drive not ready fault.** Check supply voltage / DC Bus = 1.35 x input voltage.

\* **Comm fault drive not responding.** Internal communication lost.

- Cycle Power
- Remove and reinstall panel
- Replace panel

## Fault Listing

Fault Code	Fault Name In Panel	Description and Recommended Corrective Action
1	OVERCURRENT	Output current is excessive. Check for and correct: <ul style="list-style-type: none"> <li>• Excessive motor load, pump overload.</li> <li>• Insufficient acceleration time (parameters 1301 Ramp 1 and 1302 Ramp 2).</li> <li>• Faulty motor, motor cables or connections.</li> </ul>
2	DC OVERVOLT	Intermediate circuit DC voltage is excessive. Check for and correct: <ul style="list-style-type: none"> <li>• Static or transient overvoltages in the input power supply.</li> <li>• Insufficient deceleration time (parameters 1302 Ramp 2, increase to at least 8 seconds).</li> </ul>
3	DEV OVERTEMP	Drive heatsink is overheated. Temperature is at or above 115° C (239° F). Check for and correct: <ul style="list-style-type: none"> <li>• Fan failure</li> <li>• Obstructions in the air flow</li> <li>• Dirt or dust coating on the heat sink</li> <li>• Excessive ambient temperature</li> <li>• Excessive motor load</li> <li>• Ambient temperature</li> <li>• Altitude</li> </ul>
4	SHORT CIRC	Fault current. Check for and correct: <ul style="list-style-type: none"> <li>• A short-circuit in the motor cable(s) or motor</li> <li>• Supply disturbances</li> </ul>
5	OVERLOAD	Inverter overload condition. The drive output current exceeds the ratings given in “Ratings” on pages 131-134 of this manual.
6	DC UNDERVOLT	Intermediate circuit DC voltage is not sufficient. Check for and correct: <ul style="list-style-type: none"> <li>• Missing phase in the input power supply</li> <li>• Blown fuse/check input wiring</li> <li>• Undervoltage on mains</li> </ul>
7	AI1 LOSS	Analog input 1 loss. Analog input value is less than AI1 MIN (1604). Check for and correct: <ul style="list-style-type: none"> <li>• Source and connection for analog input.</li> <li>• Parameter settings for AI1 MIN (1604).</li> </ul>
8	AI2 LOSS	Analog input 2 loss. Analog input value is less than SENSOR MIN (1506). Check for and correct: <ul style="list-style-type: none"> <li>• Source and connection for analog input.</li> <li>• Parameter settings for SENSOR MIN (1506) and (1503) TRANSDUCER MIN.</li> </ul>
9	MOT OVERTEMP	Motor is too hot, based on either the drive’s estimate or on temperature feedback device. <ul style="list-style-type: none"> <li>• Check for overloaded motor.</li> <li>• Adjust the parameters used for the estimate (1104...1109).</li> <li>• Check the temperature sensors and Group 11 parameters.</li> <li>• Check motor wiring and connections. Possible MOTOR phase loss.</li> </ul>

# FAULTS/ALARMS

Fault Code	Fault Name In Panel	Description and Recommended Corrective Action
10	PANEL LOSS	<p>Panel communication is lost and either:</p> <ul style="list-style-type: none"> <li>• Drive is in local control mode (the control panel displays LOC) or</li> <li>• Drive is in remote control mode (REM) and is parameterized to accept start/stop, direction or reference from the control panel.</li> </ul> <p>To correct check:</p> <ul style="list-style-type: none"> <li>• Communication lines and connections for control panel.</li> <li>• Parameter 2401 KEYPAD FAILURE.</li> <li>• Parameters in Group 10: Command Inputs and Group 11: Reference Select (if drive operation is REM).</li> </ul>
11	ID RUN FAIL	<p>The motor ID run was not completed successfully. Check for and correct:</p> <ul style="list-style-type: none"> <li>• Motor connections, wiring.</li> </ul>
12	MOTOR STALL	<p>Motor or process stall. Motor is operating in the stall region. Check for and correct:</p> <ul style="list-style-type: none"> <li>• Excessive load</li> <li>• Insufficient motor power</li> <li>• Blocked pump</li> </ul>
13	RESERVED	Not used
14	PUMP PROTECT	Pressure has fallen below value in Group 2403
15	LOW WATER	DI12 has been activated. Check for proper suction supply.
16	EARTH FAULT	<p>The load on the input power system is out of balance.</p> <ul style="list-style-type: none"> <li>• Check for/correct faults in the motor or motor cable.</li> <li>• Verify that motor cable does not exceed maximum specified length.</li> </ul>
17	UNDERLOAD	<p>Motor load is lower than expected. Check for and correct:</p> <ul style="list-style-type: none"> <li>• Disconnected load</li> <li>• Drive oversized</li> </ul>
18	THERM FAIL	Internal fault. The thermistor measuring the internal temperature of the drive is open or shorted. Contact your local factory representative.
19	OPEX LINK	Internal fault. A communication-related problem has been detected on the fiber optic link between the OITF and OINT boards. Contact your local factory representative.
20	OPEX PWR	Internal fault. Low voltage condition detected on OINT power supply. Contact your local factory representative.
21	CURR MEAS	<p>Internal fault. Current measurement is out of range. Contact your local factory representative.</p> <ul style="list-style-type: none"> <li>• Replace drive</li> </ul>
22	SUPPLY PHASE	<p>Ripple voltage in the DC link is too high. Check for and correct:</p> <ul style="list-style-type: none"> <li>• Missing mains phase</li> <li>• Blown fuse</li> <li>• Input wiring/connections</li> </ul>
23	RESERVED	Not used
24	OVERSPEED	<p>Motor speed is greater than 120% of the larger (in magnitude) of 1402 MINIMUM SPEED or 1401 MAXIMUM SPEED. Check for and correct:</p> <ul style="list-style-type: none"> <li>• Parameter settings for 1401 and 1402</li> <li>• Adequacy of motor braking torque</li> <li>• Applicability of torque control</li> </ul>
25	RESERVED	Not used
26	DRIVE ID	Internal fault. Configuration Block Drive ID is not valid. Contact your local factory representative.



# FAULTS/ALARMS

<b>Fault Code</b>	<b>Fault Name In Panel</b>	<b>Description and Recommended Corrective Action</b>
27	CONFIG FILE	Internal configuration file has an error. Contact your local factory representative. <ul style="list-style-type: none"> <li>• Cycle power</li> <li>• Check Group 9902 / Drive Size Type</li> </ul>
28	SERIAL 1 ERR	Fieldbus communication has timed out. Check for and correct: <ul style="list-style-type: none"> <li>• Fault setup (2409 COMM FAULT FUNC and 2410 COMM FAULT TIME).</li> <li>• Communication settings (Group 31 or 32 as appropriate).</li> <li>• Poor connections and/or noise on line.</li> </ul>
29	EFB CON FILE	Error in reading the configuration file for the fieldbus adapter.
30	FORCE TRIP	Fault trip forced by the fieldbus. See the fieldbus User's Manual.
31	EFB 1	Fault code reserved for the EFB protocol application. The meaning is protocol dependent.
32	EFB 2	
33	EFB 3	
34	MOTOR PHASE	
35	OUTP WIRING	Error in power wiring suspected. Check for and correct: <ul style="list-style-type: none"> <li>• Input power wired to drive output</li> <li>• Ground faults</li> </ul>
101	SERF CORRUPT	Error internal to the drive. Contact your local factory representative and report the error number.
102	SERF IITFILE	
103	SERF MACRO	
104	SERF EFBPROT	
105	SERF BPFIL	
201	DSP T1 OVERLOAD	Error internal to the drive. Contact your local factory representative and report the error number.
202	DSP T2 OVERLOAD	
203	DSP T3 OVERLOAD	
204	DSP STACK ERROR	
205	DSP REV ERROR	
206	OMIO ID ERROR	

Faults that indicate conflicts in the parameter settings are listed below.

1000	PAR HZRPM	Parameter values are inconsistent. Check for any of the following: <ul style="list-style-type: none"> <li>• 2001 MINIMUM SPEED &gt; 2002 MAXIMUM SPEED.</li> <li>• 2007 MINIMUM FREQ &gt; 2008 MAXIMUM FREQ.</li> <li>• 2001 MINIMUM SPEED / 9908 MOTOR NOM SPEED &gt; 128 (or &lt; -128).</li> <li>• 2002 MAXIMUM SPEED / 9908 MOTOR NOM SPEED &gt; 128 (or &lt; -128).</li> <li>• 2007 MINIMUM FREQ / 9907 MOTOR NOM FREQ &gt; 128 (or &lt; -128).</li> <li>• 2008 MAXIMUM FREQ / 9907 MOTOR NOM FREQ &gt; 128 (or &lt; -128).</li> </ul>
1001	PAR PFCREFNG	Parameter values are inconsistent. Check for the following: <ul style="list-style-type: none"> <li>• 2007 MINIMUM FREQ is negative.</li> </ul>
1003	PAR AI SCALE	Parameter values are inconsistent. Check for any of the following: <ul style="list-style-type: none"> <li>• 1503 TRANSDUCER MIN &gt; 1502 TRANSDUCER MAX.</li> </ul>
1004	PAR AO SCALE	Parameter values are inconsistent. Check for any of the following: <ul style="list-style-type: none"> <li>• 1904 AO 1 MIN &gt; 1905 AO 1 MAX.</li> <li>• 1909 AO 2 MIN &gt; 1910 AO 2 MAX.</li> </ul>

# FAULTS/ALARMS

Fault Code	Fault Name In Panel	Description and Recommended Corrective Action
1005	PAR PCU 2	Parameter values for power control are inconsistent: Improper motor nominal kVA or motor nominal power. Check for the following: <ul style="list-style-type: none"> <li>• <math>1.1 \leq (1104 \text{ MOTOR NOM CURR} * 1103 \text{ MOTOR NOM VOLT} * 1.73 / P_N) \leq 2.6</math></li> <li>• Where: <math>P_N = 1000 * 1107 \text{ MOTOR NOM POWER}</math> (if units are kW) or <math>P_N = 746 * 1107 \text{ MOTOR NOM POWER}</math> (if units are HP, e.g. in US)</li> </ul>
1007	PAR FBUS	Parameter values are inconsistent. Check for and correct: <ul style="list-style-type: none"> <li>• A parameter is set for fieldbus control (e.g. 1201 START/STOP = Fieldbus), but 3001 COMM PROT SEL = 0.</li> </ul>
1009	PAR PCU 1	Parameter values for power control are inconsistent: Improper motor nominal frequency or speed. Check for both of the following: <ul style="list-style-type: none"> <li>• <math>1 \leq (60 * 1105 \text{ MOTOR NOM FREQ} / 1106 \text{ MOTOR NOM SPEED}) \leq 16</math></li> <li>• <math>0.8 \leq 1106 \text{ MOTOR NOM SPEED} / (120 * 1105 \text{ MOTOR NOM FREQ} / \text{Motor Poles}) \leq 0.992</math></li> </ul>

## Fault Resetting

The AQUAVAR can be configured to automatically reset certain faults. Refer to parameter Group 24: Fault Functions and Group 25: Automatic Reset.



**Warning!** If an external source for start command is selected and it is active, the AQUAVAR may start immediately after fault reset.

### Flashing Red LED

To reset the drive for faults indicated by a flashing red LED:

- Turn the power off for 5 minutes.

### Red LED

To reset the drive for faults indicated by a red LED (on, not flashing), correct the problem and do one of the following:

- From the control panel: Press RESET
- Turn the power off for 5 minutes.

**NOTE:** In some cases a fault reset “soft key” will appear on the display. Press this button to reset, then press the start key.

- When the fault has been removed, the motor can be started.

## Fault History

For reference, the last three fault codes are stored in Group 01: VFD Signals. Specifically parameters 0116...0118. The Aquavar CPC stores additional fault data, which helps the operator identify operating conditions at the time of fault. (Parameters 0119...0126).

To clear the fault history, go to PAR GROUPS 01, VFD SIGNALS. Press the SEL key. Down arrow to 0116 LAST FAULT, then press the EDIT key. Next press the UP and DOWN arrow at the same time until NO RECORD shows on the display. This clears all the faults in the history.

# FAULTS/ALARMS

## Correcting Alarms

The recommended corrective action for alarms is:

- Determine if the Alarm requires any corrective action (action is not always required).
- Use "Alarm Listing" below to find and address the root cause of the problem.
- Press the reset key (when available) or turn the power off for at least 5 minutes.

## Alarm Listing

The following table lists the alarms by code number and describes each.

Alarm Code	Display	Description
2001	Reserved	
2002		
2003		
2004	DIR LOCK	The change in direction being attempted is not allowed. Either: <ul style="list-style-type: none"> <li>• Do not attempt to change the direction of motor rotation.</li> </ul>
2005	I/O COMM	Fieldbus communication has timed out. Check for and correct: <ul style="list-style-type: none"> <li>• Fault setup (2411 COMM FAULT FUNC and 2412 COMM FAULT TIME).</li> <li>• Communication settings (Group 31 or 32 as appropriate).</li> <li>• Poor connections and/or noise on the line.</li> </ul>
2006	AI1 LOSS	Analog Input 1 is lost, or value is less than the minimum setting. Check: <ul style="list-style-type: none"> <li>• Input source and connections</li> <li>• Parameter that sets the minimum (1604)</li> </ul>
2007	TRANSDUCER LOSS	Analog Input 2 is lost, or value is less than the minimum setting. Check: <ul style="list-style-type: none"> <li>• Transducer, connection and wiring</li> <li>• Input source and connections</li> <li>• Parameter that sets the minimum (1506)</li> </ul>
2008	PANEL LOSS	Panel communication is lost and either: <ul style="list-style-type: none"> <li>• Drive is in local control mode (the control panel displays LOC), or</li> <li>• Drive is in remote control mode (REM) and is parameterized to accept start/stop, direction or reference from the control panel.</li> </ul> To correct check: <ul style="list-style-type: none"> <li>• Communication lines and connections</li> <li>• Parameter 2401 KEYPAD FAILURE</li> </ul>
2009	RESERVED	

# FAULTS/ALARMS

<b>Alarm Code</b>	<b>Display</b>	<b>Description</b>
2010	MOT OVERTEMP	Motor is hot, based on either the drive's estimate or on temperature feedback. This alarm warns that a Motor Underload fault trip may be near. Check: <ul style="list-style-type: none"> <li>• Check for overloaded motor, pump.</li> </ul>
2011	UNDERLOAD	Motor load is lower than expected. This alarm warns that a Motor Underload fault trip may be near. Check: <ul style="list-style-type: none"> <li>• Motor and drive ratings match (motor is NOT undersized for the drive).</li> </ul>
2012	MOTOR STALL	Motor is operating in the stall region. This alarm warns that a Motor Stall fault trip may be near. Check motor connections.
2013 (note 1)	AUTORESET	This alarm warns that the drive is about to perform an automatic fault reset, which may start the motor. <ul style="list-style-type: none"> <li>• To control automatic reset, use parameter Group 12 AUTOMATIC RESET.</li> </ul>
2015	ALARM 2015 PUMP PROTECT	Pump protection has been triggered via parameter 2403 (protection limit) and 2404 (protection delay). This protection is enabled when the pump reaches maximum frequency and cannot maintain system set point for the specific delay time. Check for air entrainment, plugged impeller, blocked suction, lack of NPSHa, pump run-out.
2016	LOW WATER	Check DI2 contact or suction switch continuity.
2017	NOT USED	
2023	E-STOP FAULT	Check jumper / connection, between Terminal 10 and 15 (DI3).

# MAINTENANCE (Frame Sizes R1-R6)



**WARNING!** Read "Safety" on page 7 before performing any maintenance on the equipment. Ignoring the safety instructions can cause injury or death.

## Maintenance Intervals

If installed in an appropriate environment, the drive requires very little maintenance. This table lists the routine maintenance intervals recommended by CentriPro.

Maintenance	Interval	Instruction
Heatsink Temperature Check and Cleaning	Depends on the dustiness of the environment (every 6... 12 months).	See "Heatsink" on page 122
Main Cooling Fan Replacement	Every five years	See "Main Fan Replacement" on pages 122, 123, 126 and 127
Internal Enclosure Cooling Fan Replacement (IP 54/UL Type 12 units)	Every three years	See "Internal Enclosure Fan Replacement" on page 123
Capacitor Change (Frame size R5 and R6)	Every ten years	See "Capacitors" on page 124
Replace Battery in Advanced Control Panel	Every ten years	See "Battery" on page 124

## Heatsink

The heatsink fins accumulate dust from the cooling air. Since a dusty heatsink is less efficient at cooling the drive, overtemperature faults become more likely. In a "normal" environment (not dusty, clean) check the heatsink annually, in a dusty environment check more often.

Clean the heatsink as follows (when necessary):

1. Remove power from drive
2. Remove the cooling fan (see section "Main Fan Replacement" below)
3. Blow clean compressed air (not humid) from bottom to top and simultaneously use a vacuum cleaner at the air outlet to trap the dust.

**Note:** If there is a risk of the dust entering adjoining equipment, perform the cleaning in another room.

4. Replace the cooling fan
5. Restore power

## Main Fan Replacement

The drive's main cooling fan has a life span of about 60,000 operating hours at maximum rated operating temperature and drive load. The expected life span doubles for each 10° C (18° F) drop in the fan temperature (fan temperature is a function of ambient temperatures and drive loads).

Fan failure can be predicted by the increasing noise from fan bearings and the gradual rise in the heatsink temperature in spite of heatsink cleaning. If the drive is operated in a critical part of a process, fan replacement is recommended once these symptoms start appearing. Replacement fans are available from the factory. Do not use other than factory specified spare parts.

# MAINTENANCE (Frame Sizes R1-R6)

## Frame Size R1...R4

To replace the fan:

1. Remove power from drive
2. Remove drive cover
3. For Frame Size:
  - R1, R2: Press together the retaining clips on the fan cover sides and lift.
  - R3, R4: Press in on the lever located on the left side of the fan mount and rotate the fan up and out.
4. Disconnect the fan cable.
5. Install the fan in reverse order
6. Restore power

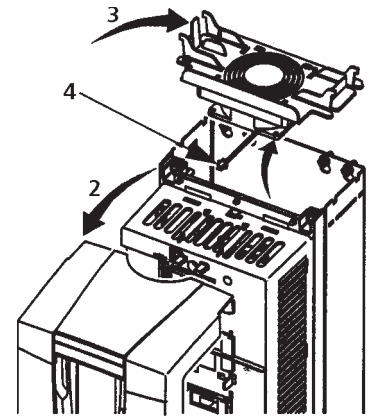

X0021

## Frame Size R5 and R6

To replace the fan:

1. Remove power from drive
2. Remove the screws attaching the fan
3. Disconnect the fan cable.
4. Install the fan in reverse order
5. Restore power

Bottom View (R5)

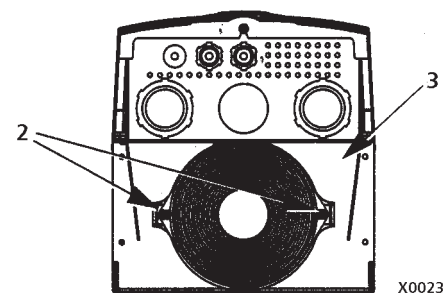

X0023

Bottom View (R6)

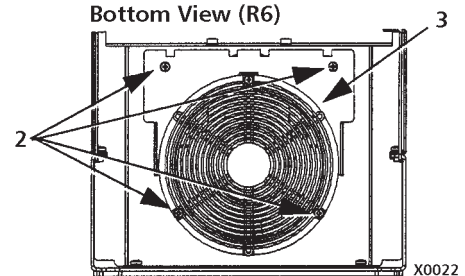

X0022

## Internal Enclosure Fan Replacement

IP 54 / UL Type 12 enclosures have an additional internal fan to circulate air inside the enclosure.

### Frame Size R1 to R4

To replace the internal enclosure fan in frame sizes R1 to R4:

1. Remove power from drive
2. Remove the front cover
3. The housing that holds the fan in place has barbed retaining clips at each corner. Press all four clips toward the center to release the barbs.
4. When the clips/barbs are free, pull the housing up to remove from the drive.
5. Disconnect the fan cable
6. Install the fan in reverse order
  - The fan air flow is up (refer to arrow on fan)
  - The fan wire harness is toward the front
  - The notched housing barb is located in the right-rear corner
  - The fan cable connects just forward of the fan at the top of the drive

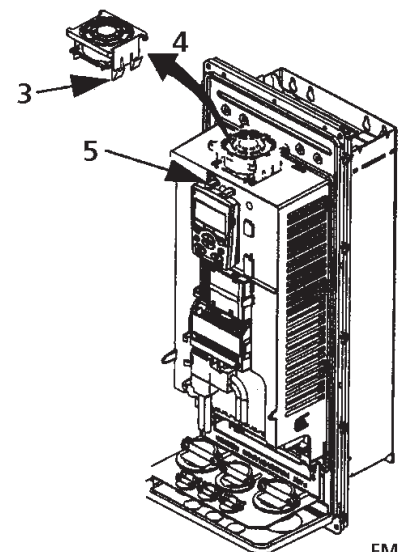

FM

# MAINTENANCE (Frame Sizes R1-R6)

## Frame Size R5 and R6

To replace the internal enclosure fan in frame sizes R5 or R6:

1. Remove power from drive
2. Remove the front cover
3. Lift the fan out and disconnect the cable
4. Install the fan in reverse order
5. Restore power

## Capacitors

The drive intermediate circuit employs several electrolytic capacitors. Their life span is from 35,000...90,000 hours depending on drive loading and ambient temperature. Capacitor life can be prolonged by lowering the ambient temperature.

It is not possible to predict a capacitor failure. Capacitor failure is usually followed by a input power fuse failure or a fault trip. Contact factory if capacitor failure is suspected. Replacements for frame size R5 and R6 are available from the factory. Do not use other than factory specified spare parts.

## Control Panel

### Cleaning

Use a soft damp cloth to clean the control panel. Avoid harsh cleaners which could scratch the display window.

### Battery

A battery is only used in control panels that have the clock function available and enabled. The battery keeps the clock operating in memory during power interruptions. To remove the battery, use a coin to rotate the battery holder on the back of the control panel. Replace the battery with type CR2032.

# MAINTENANCE (Frame Sizes R7-R8)

## Layout

The layout stickers of the drive are shown below. The stickers show all possible components concerning maintenance activities. Not all of them are present in each delivery.

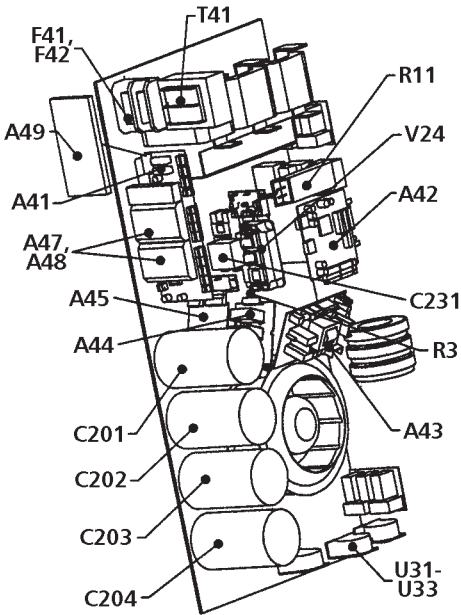
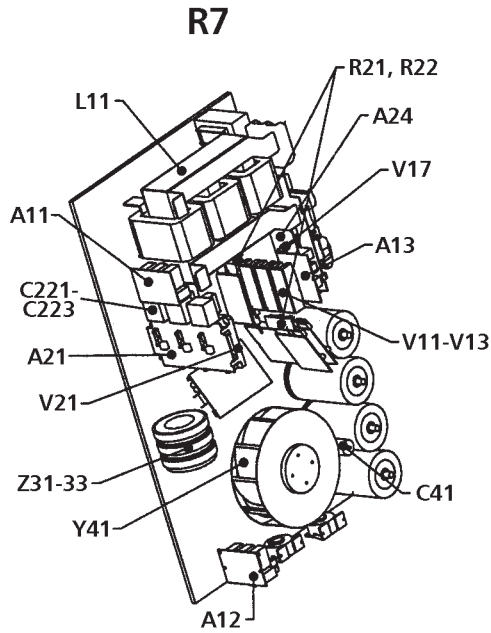

Code: 64572261

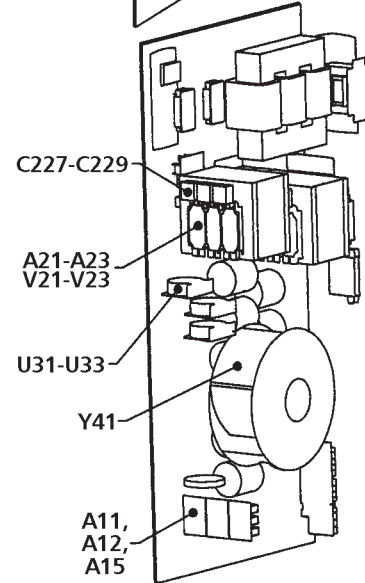
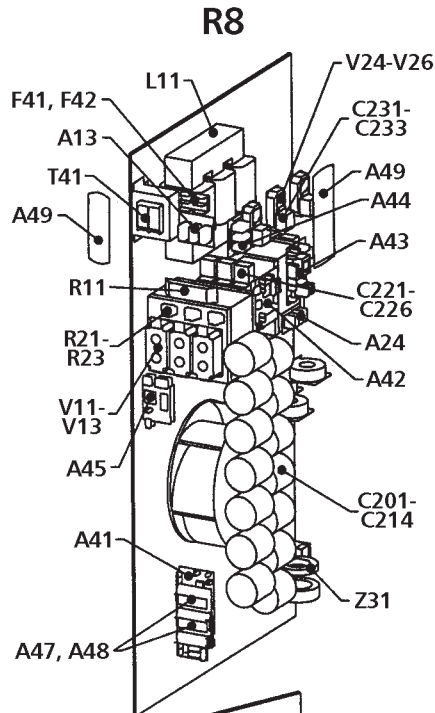

Code: 64601423

### Designation

- A49
- A41
- Y41
- C\_

### Component

- Control Panel
- Motor Control and I/O Board (OMIO)
- Cooling Fan
- Capacitors



# MAINTENANCE (Frame Sizes R1-R6)

## Heatsink

The heatsink fins pick up dust from the cooling air. The drive runs into overtemperature warnings and faults if the heatsink is not clean. In a “normal” environment (not dusty, not clean) the heatsink should be checked annually, in a dusty environment more often.

### Clean the heatsink as follows (when necessary):

1. Remove the cooling fan (see section “Fan” below).
2. Blow dry clean compressed air from bottom to top and simultaneously use a vacuum cleaner at the air outlet to trap the dust. **Note:** Prevent dust from entering adjoining equipment.
3. Replace the cooling fan

## Fan

The life span of the cooling fan of the drive is about 50,000 (R7) and 60,000 (R8) hours. The actual life span depends on the running time of the fan, ambient temperature and dust concentration. See the appropriate Aquavar CPC User Manual for the actual signal which indicates the running time of the cooling fan.

Replacement fans are available from CentriPro. Do not use other than factory specified spare parts.

### Replacing the Fan (R7)

1. Remove the upper front cover and disconnect the control panel cables.
2. Disconnect the discharging resistor wire.

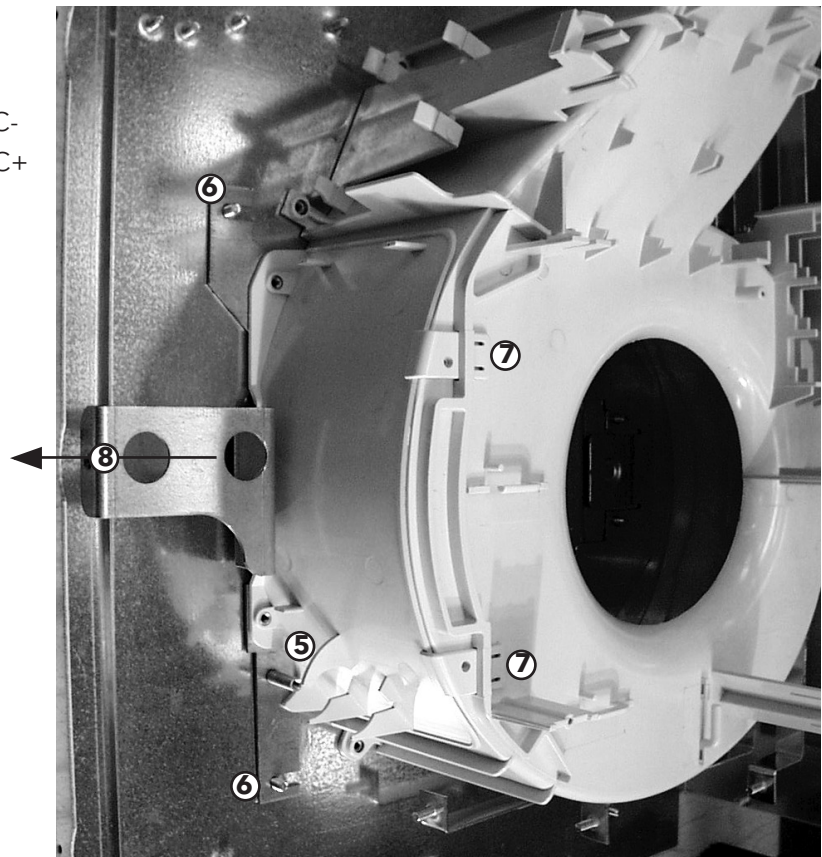
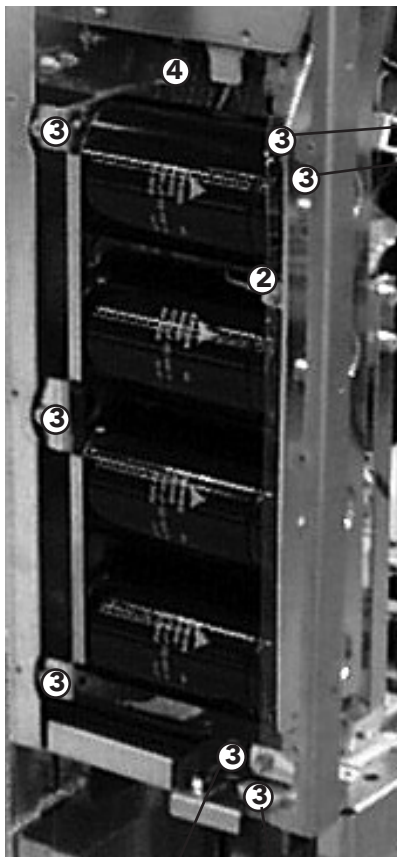

## MAINTENANCE (Frame Sizes R7-R8)

3. Remove the DC capacitor pack by undoing the black fixing screws.
4. Disconnect the fan supply wires (detachable terminal).
5. Disconnect the fan capacitor wires.
6. Undo the black fixing screws of the fan cassette.
7. Press the snap-on holders to release the side cover.
8. Lift from the handle and pull the fan cassette out.
9. Install the fan in reverse order to the above and replace the fan capacitor.

### Replacing the Fan (R8)

1. Remove the upper front cover.
2. Remove the OMIO board.
3. Disconnect the fan capacitor and power supply wires. Replace the starting capacitor.
4. Undo the black fastening screws of the plastic side cover of the fan and lift the cover off.
5. Undo the black fastening screws of the fan.
6. Lift the fan out of the cabinet.
7. Install the fan in reverse order to the above.

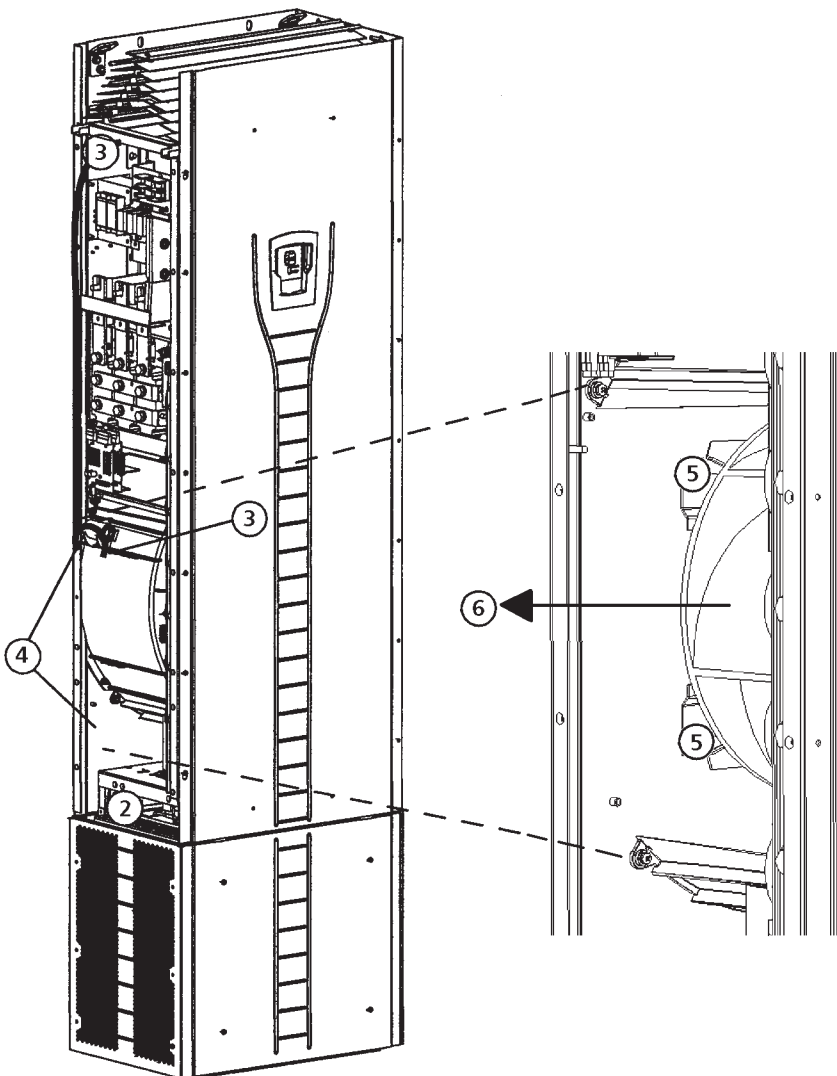

# MAINTENANCE (Frame Sizes R1-R6)

## Capacitors

The drive intermediate circuit employs several electrolytic capacitors. Their life span is at least 90,000 hours depending on the operating time of the drive, loading and ambient temperature. Capacitor life can be prolonged by lowering the ambient temperature.

It is not possible to predict a capacitor failure. Capacitor failure is usually followed by damage to the unit and an input cable fuse failure or a fault trip. Contact your CentriPro authorized Aquavar CPC distributor or the factory.

## Replacing the Capacitor Pack (R7)

Replace the capacitor pack as described in section "Replacing the Fan (R7)" on page 126.

## Replacing the Capacitor Pack (R8)

1. Remove the upper front cover and the side plate equipped with control panel mounting slot.
2. Disconnect the discharging resistor wire.
3. Undo the fastening screws.
4. Lift the capacitor pack out.
5. Install the capacitor pack in reverse order to the above.

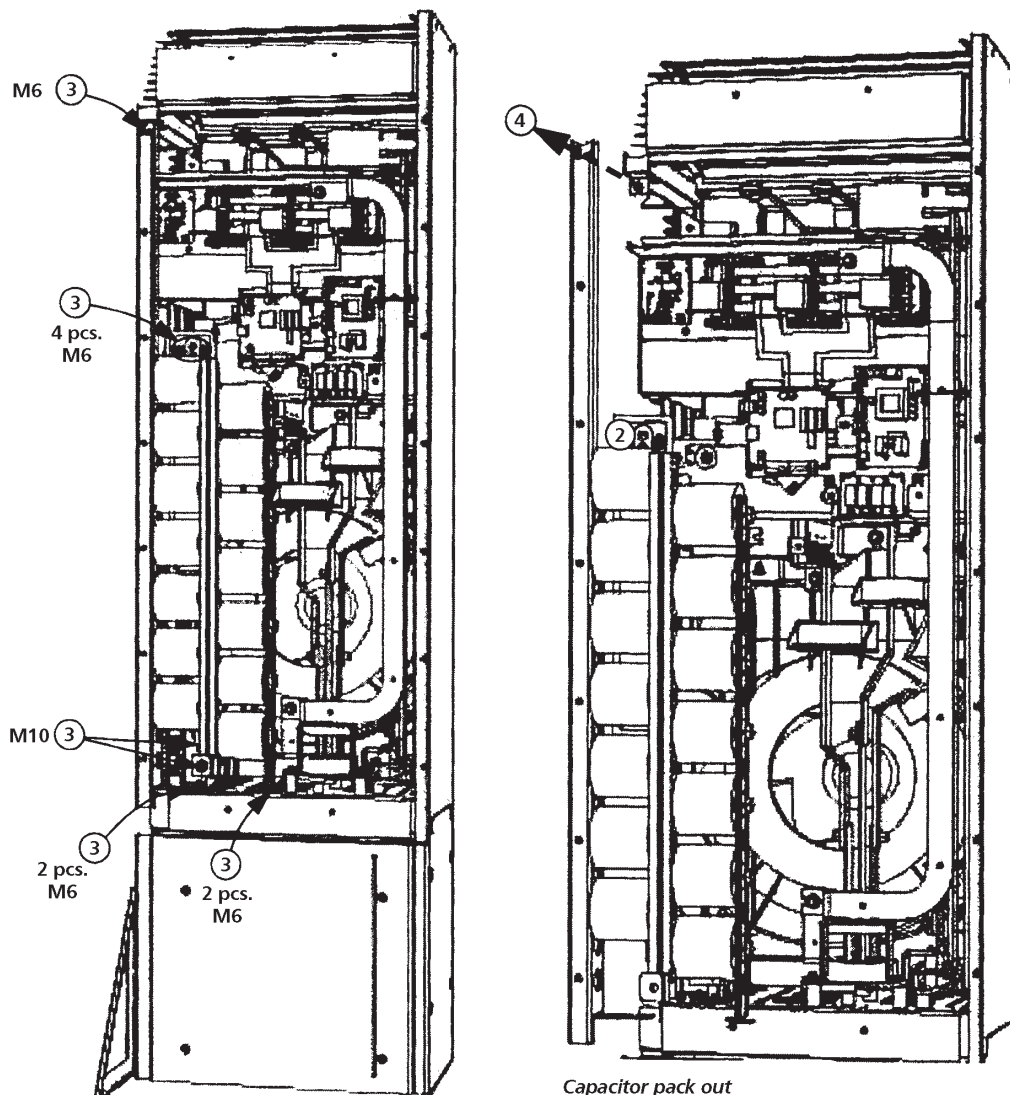

# MAINTENANCE (Frame Sizes R7-R8)

## LEDs

This table describes LEDs of the drive.

Where	LED	When the LED is lit
OMIO Board	Red (blinking)	Drive in fault state.
	Green	The power supply on the board is OK.
Control Panel Mounting Platform	Red	Drive in fault state.
	Green	The main +24 V power supply for the control panel and the OMIO board is OK.
OITF Board	V204 (green)	+5 V voltage of the board is OK.
	V309 (red)	Prevention of unexpected start is ON.
	V310 (green)	IGBT control signal transmission to the gate driver control boards is enabled.

## Control Panel

### Cleaning

Use a soft damp cloth to clean the control panel. Avoid harsh cleaners which could scratch the display window.

### Battery

A battery is only used in Assistant Control Panels that have the clock function available and enabled. The battery keeps the clock operating in memory during power interruptions.

The expected life for the battery is greater than ten years. To remove the battery, use a coin to rotate the battery holder on the back of the control panel. Replace the battery with type CR2032.

# TECHNICAL DATA

## Sizing

The current ratings are the same regardless of the supply voltage within one voltage range. To achieve the rated motor power given in the table, the rated current of the drive must be higher than or equal to the rated motor current.

**Note 1:** The maximum allowed motor shaft power is limited to  $1.5 \cdot I_A$  Times Rated HP. If the limit is exceeded, motor torque and current are automatically restricted. The function protects the input bridge of the drive against overload.

**Note 2:** The ratings apply in ambient temperature of 40° C (104° F).

## Derating

The load capacity (current and power) decreases if the installation site altitude exceeds 1000 meters (3300 ft), or if the ambient temperature exceeds 40° C (104° F) or if 8 kHz switching frequency (parameter 5001) is used.

### Temperature Derating

In the temperature range +40° C...50° C (+104° F...122° F) the rated output current is decreased 1% for every 1° C (1.8° F) above +40° C (+104° F). The output current is calculated by multiplying the current given in the rating table by the derating factor.

Example: If the ambient temperature is 50° C (+122° F) the derating factor is

$$100\% - 1\%/^{\circ}\text{C} \times 10^{\circ}\text{C} = 90\% \text{ or } 0.90.$$

The output current is then  $0.90 \times I_{2N}$  or  $0.90 \times I_{2hd}$ .

### Altitude Derating

The derating is 1% for every 100 m (330 feet) above 3300 feet. If the installation site is higher than 2000 m (6600 feet) above sea level, please contact the factory for assistance.

### Single Phase Supply Derating

For 208...240 Volt series drives, a single phase supply can be used. In that case, the derating is 50%, for the maximum amps and corresponding power rating of the three phase drive at 208-230 Volt input.

### Switching Frequency Derating

If the 8 kHz switching frequency (parameter 5001) is used, derate HP and current output to 80%.

# TECHNICAL DATA

## Cable Sizing/Ratings

### 208...240 Volt Drives

The following tables provide current, horsepower, frame size and recommended cable sizes for the Aquavar CPC.

CENTRIPRO AQUAVAR CPC							
Voltage	Phase	NEMA 1 Base Model	Full Load Amps	NORMAL DUTY HORSEPOWER	Frame Size <sup>2</sup>	Output Cable Size Min. AWG <sup>1</sup>	Input Cable Size Min. AWG <sup>1</sup>
230	1	CPC20171	8.5	2	R1	14	10
		CPC20241	12	3	R2	12	8
		CPC20311	15.5	5	R2	12	8
		CPC20461	23	7.5	R3	10	6
		CPC20591	29.5	10	R3	8	4
		CPC20881	44.0	15	R4	6	2
		CPC21141	57.0	20	R4	4	1/0
		CPC21431	71.5	25	R6	3	3/0
		CPC21781	89.0	30	R6	2	4/0
		CPC22211	110.5	40	R6	1/0	300MCM
		CPC22481	124.0	50	R6	2/0	350MCM
230	3	CPC20121	11.8	3	R1	14	14
		CPC20171	16.7	5	R1	10	10
		CPC20241	24.2	7.5	R2	8	8
		CPC20311	30.8	10	R2	8	8
		CPC20461	46.2	15	R3	6	6
		CPC20591	59.4	20	R3	4	4
		CPC20751	74.8	25	R4	3	3
		CPC20881	88.0	30	R4	2	2
		CPC21141	114.0	40	R4	1/0	1/0
		CPC21431	143.0	50	R6	3/0	3/0
		CPC21781	178.0	60	R6	4/0	4/0
		CPC22211	221.0	75	R6	300MCM	300MCM
		CPC22481	248.0	100	R6	350MCM	350MCM

(1) Recommended AWG Size based on NEC table 310.16, 40° C ambient, 90° C, UL type copper wire. For other wire sizes or types, consult local, state or NEC codes.

(2) Frame sizes R7 and R8, the Aquavar CPC will have multiple conductor terminals for each phase. Consult technical section (CABLE TERMINALS).

# TECHNICAL DATA

## Cable Sizing/Ratings

### 380...480 Volt Drives

The following table provides Aquavar CPC rating information and recommended wire sizing for the input and output cables.

Voltage	Phase	CENTRIPRO AQUAVAR CPC			Frame Size <sup>2</sup>	Output Cable Size Min. AWG <sup>1</sup>	Input Cable Size Min. AWG <sup>1</sup>
		NEMA 1 Base Model	Full Load Amps	NORMAL DUTY HORSEPOWER			
460	3	CPC40061	6.9	3	R1	14	14
		CPC40081	8.8	5	R1	14	14
		CPC40121	11.9	7.5	R1	14	14
		CPC40151	15.4	10	R2	12	12
		CPC40231	23	15	R2	12	12
		CPC40311	31	20	R3	10	8
		CPC40381	38	25	R3	8	8
		CPC40451	45	30	R3	8	6
		CPC40591	59	40	R4	6	4
		CPC40721	72	50	R4	4	3
		CPC40771	77	60	R4	4	3
		CPC40971	97	75	R4	3	1
		CPC41251	125	100	R5	1	2/0
		CPC41571	157	125	R6	2/0	3/0
		CPC41801	180	150	R6	3/0	4/0
		CPC42451	245	200	R7	350MCM	350MCM
		CPC43161	316	250	R7	2 X 250MCM	2 X 250MCM
		CPC43681	368	300	R8	2 X 300MCM	2 X 300MCM
		CPC44141	414	350	R8	2 X 400MCM	2 X 400MCM
		CPC44861	486	400	R8	2 X 500MCM	2 X 500MCM
CPC45261	526	450	R8	2 X 350MCM	2 X 350MCM		
CPC46021	602	500	R8	2 X 500MCM	2 X 500MCM		
CPC46451	645	550	R8	2 X 500MCM	2 X 500MCM		

(1) Recommended AWG Size based on NEC table 310.16, 40° C ambient, 90° C, UL type copper wire. For other wire sizes or types, consult local, state or NEC codes.

(2) Frame sizes R7 and R8, the Aquavar CPC will have multiple conductor terminals for each phase. Consult technical section (CABLE TERMINALS) for maximum wire diameter and torque values.



# TECHNICAL DATA

## Fuse Sizing/Ratings

### 208...240 Volt Drives

Branch circuit protection must be provided by the end user, electrical contractor or distributor, sized per local, state or local National Electrical Codes. Recommendations for fused circuit protection are in the following tables.

CENTRIPRO AQUAVAR CPC							
Voltage	Phase	NEMA 1 Base Model	Full Load Amps	NORMAL DUTY HORSEPOWER	Frame Size	Input Current Amps	Fuse Type <sup>3</sup> JJN
230	1	CPC20171	8.5	2	R1	17.3	20
		CPC20241	12	3	R2	24.5	30
		CPC20311	15.5	5	R2	31.6	40
		CPC20461	23	7.5	R3	46.9	60
		CPC20591	29.5	10	R3	60.2	70
		CPC20881	44.0	15	R4	89.8	110
		CPC21141	57.0	20	R4	116.3	150
		CPC21431	71.5	25	R6	145.9	175
		CPC21781	89.0	30	R6	181.6	225
		CPC22211	110.5	40	R6	225.4	300
		CPC22481	124.0	50	R6	252.9	300
230	3	CPC20121	11.8	3	R1	12.0	15
		CPC20171	16.7	5	R1	17.0	25
		CPC20241	24.2	7.5	R2	24.7	30
		CPC20311	30.8	10	R2	31.4	40
		CPC20461	46.2	15	R3	47.1	60
		CPC20591	59.4	20	R3	60.6	70
		CPC20751	74.8	25	R4	76.3	90
		CPC20881	88.0	30	R4	89.8	110
		CPC21141	114.0	40	R4	116.3	150
		CPC21431	143.0	50	R6	145.9	175
		CPC21781	178.0	60	R6	181.6	225
		CPC22211	221.0	75	R6	225.4	300
		CPC22481	248.0	100	R6	252.9	300

(3) UL Class T fuses are recommended for short circuit protection. Very fast acting Bussmann\* T-tron type JJN and JJS are shown in the Aquavar CPC tables. Other manufacturers are acceptable if they meet fuse requirements.

\* Bussmann is a registered trademark of Cooper Industries Inc.



# TECHNICAL DATA

## Fuse Sizing/Ratings

### 380...480 Volt Drives

The following table provides Aquavar CPC rating information and recommended fuse sizing for the input short circuit protection. Branch circuit protection must be provided by the end user, contractor or distributor. Sized according to local or applicable NEC codes.

CENTRIPRO AQUAVAR CPC							
Voltage	Phase	NEMA 1 Base Model	Full Load Amps	NORMAL DUTY HORSEPOWER	Frame Size	Input Current Amps	Fuse Type <sup>3</sup> JJN
460	3	CPC40061	6.9	3	R1	7.0	10
		CPC40081	8.8	5	R1	9.0	15
		CPC40121	11.9	7.5	R1	12.1	15
		CPC40151	15.4	10	R2	15.7	20
		CPC40231	23	15	R2	23.5	30
		CPC40311	31	20	R3	31.6	40
		CPC40381	38	25	R3	38.8	45
		CPC40451	45	30	R3	44.9	60
		CPC40591	59	40	R4	60.2	70
		CPC40721	72	50	R4	73.4	90
		CPC40771	77	60	R4	78.5	90
		CPC40971	97	75	R4	98.0	125
		CPC41251	125	100	R5	126.5	150
		CPC41571	157	125	R6	160.1	200
		CPC41801	180	150	R6	183.6	225
		CPC42451	245	200	R7	250.0	300
		CPC43161	316	250	R7	322.3	400
		CPC43681	368	300	R8	375.4	450
		CPC44141	414	350	R8	422.3	500
		CPC44861	486	400	R8	495.8	600
CPC45261	526	450	R8	536.5	800		
CPC46021	602	500	R8	614.0	800		
CPC46451	645	550	R8	658.0	800		

(3) UL Class T fuses are recommended for short circuit protection. Very fast acting Bussmann\* T-tron type JJN and JJS are shown in the Aquavar CPC tables. Other manufacturers are acceptable if they meet fuse requirements.

# TECHNICAL DATA

## Cable Terminals (Frames R1-R6)

Mains and motor cable maximum sizes (per phase) accepted at the cable terminals and the tightening torques are listed below.

Frame Size	U1, V1, W1 U2, V2, W2				Earthing PE "Ground"				Control Wire			
	Maximum Wire Size		Torque		Maximum Wire Size		Torque		Maximum Wire Size		Torque	
	mm <sup>2</sup>	AWG	Nm	lb-ft	mm <sup>2</sup>	AWG	Nm	lb-ft	mm <sup>2</sup>	AWG	Nm	lb-ft
R1	6	8	1.4	1.0	4	10	1.4	1.0	1.5	16	0.4	0.3
R2	10	6	1.4	1.0	10	8	1.4	1.0				
R3	25	3	1.8	1.3	16	6	1.8	1.3				
R4	50	1/0	2.0	1.5	35	2	2.0	1.5				
R5	70	2/0	15	11.1	70	2/0	15	11.1				
R6	185	350 MCM	40	29.5	95	4/0	8	5.9				

## Cable Terminals (Frames R7-R8)

Mains and motor cable maximum sizes (per phase) accepted at the cable terminals and the tightening torques are listed below.

Frame Size	U1, V1, W1, U2, V2, W2					Earthing PE			
	Number of holes per phase	Cable Diameter		Screw	Tightening Torque		Screw	Tightening Torque	
		mm	in		Nm	lb-ft		Nm	lb-ft
R7 <sup>①</sup>	2	58	2.28	M12	50...75	35...55	M8	15...22	10...16
R8 <sup>①</sup>	3	58	2.28	M12	50...75	35...55	M8	15...22	10...16

① **NOTE:** Maximum AWG size for R7 Frame is (2) x 500MCM.  
Maximum AWG size for R8 Frame is (3) x 500MCM.

# TECHNICAL DATA

## Input Power (Mains) Connection

Input Power (Mains) Connection Specifications	
<b>Voltage (<math>U_1</math>)</b>	208/220/230/240 VAC 3-phase (1-phase) +10%-15% for CPC2XXXX. 400/415/440/460/480 VAC 3-phase +10%-15% for CPC4XXXX.
<b>Prospective Short-Circuit Current (IEC 629)</b>	Maximum allowed prospective short-circuit current in the supply is 65 kA in a second providing that the mains cable of the drive is protected with appropriate fuses. US: 65,000 AIC.
<b>Frequency</b>	48...63 Hz
<b>Imbalance</b>	Max. $\pm 3\%$ of nominal phase to phase input voltage.
<b>Fundamental Power Factor (<math>\cos \phi_1</math>)</b>	0.98 (at nominal load)
<b>Cable Temperature Rating</b>	90° C (194° F) rating minimum

## Motor Connection

Motor Connection Specifications			
<b>Voltage (<math>U_2</math>)</b>	0... $U_1$ , 3-phase symmetrical, $U_{max}$ at the field weakening point.		
<b>Frequency</b>	0...500 Hz		
<b>Frequency Resolution</b>	0.01 Hz		
<b>Current</b>	See "Ratings" on pages 131-134		
<b>Power Limit</b>	1.5 x Rated HP		
<b>Field Weakening Point</b>	10...60 Hz		
<b>Switching Frequency</b>	Selectable: 1, 4 or 8 kHz		
<b>Cable Temperature Rating</b>	90° C (194° F) rating minimum		
<b>Maximum Motor Cable Length</b>	<b>Frame Size</b>	<b>Maximum Motor Cable Length</b>	
		<b><math>f_{sw} = 1 \text{ or } 4 \text{ kHz}</math></b>	<b><math>f_{sw} = 8 \text{ kHz}</math></b>
	R1	100 m	50 m
	R2 - R4	200 m	100 m
	R5 - R6	300 m	150 m
R7 - R8	300 m	NA	



**WARNING!** Using a motor cable longer than specified in the chart above may cause permanent damage to the drive or motor.



**WARNING!** Use of an output load filter or reactor is required when motor leads exceed the above recommendations. Consult motor manufacturer on required use of inverter drives.

# TECHNICAL DATA

## Control Connection

<b>Control Connection Specifications</b>	
<b>Analog Inputs and Outputs</b>	See table heading "Hardware Description" on page 29.
<b>Digital Inputs</b>	Digital input impedance 1.5 k $\Omega$ . Maximum voltage for digital inputs is 30 V.
<b>Relays (Digital Outputs)</b>	<ul style="list-style-type: none"> <li>• Maximum contact voltage: 30 V DC, 250 V AC</li> <li>• Maximum contact current / power: 6 A, 30 V DC; 1500 VA, 250 V AC</li> <li>• Maximum. continuous current: 2 A rms (<math>\cos \varphi = 1</math>), 1 A rms (<math>\cos \varphi = 0.4</math>)</li> <li>• Minimum load: 500 mW (12 V, 10 mA)</li> <li>• Contact material: Silver-nickel (AgN)</li> <li>• Isolation between relay digital outputs, test voltage: 2.5 kV rms, 1 minute</li> </ul>
<b>Cable Specifications</b>	See "Control Cables" on page 17.

## Efficiency (Frames R1-R8)

Approximately 98% at nominal power level.

## Cooling (Frames R1-R6)

<b>Cooling Specifications</b>	
<b>Method</b>	Internal fan, flow direction from bottom to top.
<b>Requirement</b>	<b>Free space around the unit:</b> <ul style="list-style-type: none"> <li>• 200 mm (8 in) above and below the unit.</li> <li>• 25 mm (1 in) along each side of the unit.</li> </ul>

# TECHNICAL DATA

## Cooling (Frames R7-R8)

### Installation Procedure

Choose the mounting orientation (a, b, c or d).

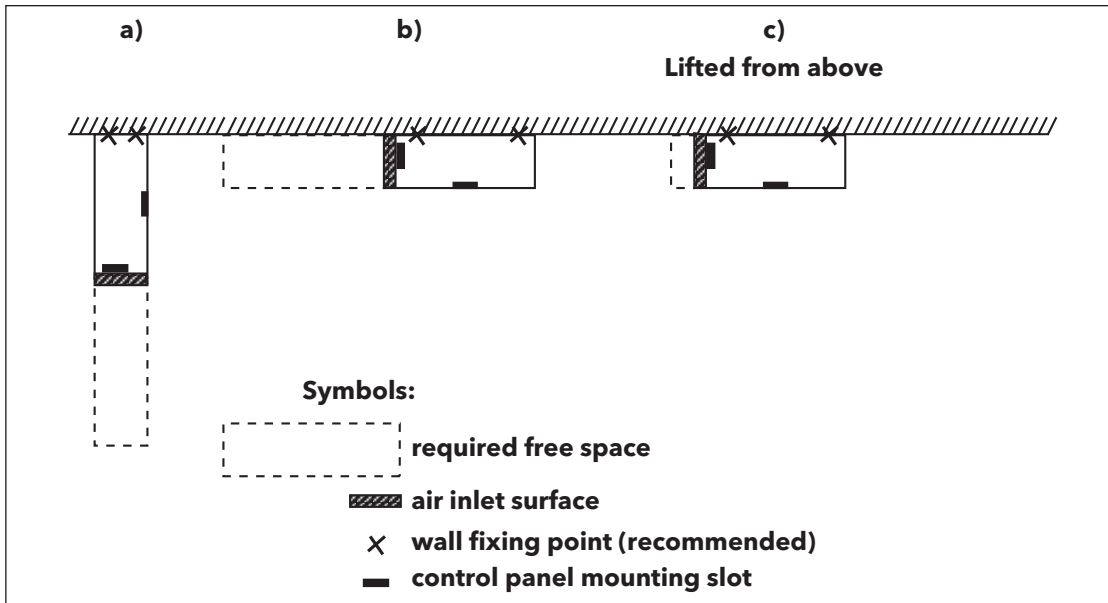

Frame Size	Mounting Orientation	Required Free Space Around the Unit for Mounting, Maintenance, Service and Cooling*					
		Front		Side		Above	
		mm	in	mm	in	mm	in
R7	a,d	500	20	-	-	200	7.9
	b	-	-	500	20	200	7.9
	c	-	-	200**	7.9**	lifting space	lifting space
R8	a,d	600	24	-	-	300	12
	b	-	-	600	24	300	12
	c	-	-	300**	12**	lifting space	lifting space

\* Space for the installer not included.

\*\* Space for the fan and capacitor replacement not included.

### Mounting orientations a and b

#### Make holes in the wall (recommended):

1. Lift the unit against the wall into the mounting place.
2. Mark the locations for the two fixing points in the wall.
3. Mark the bottom edges of the unit to the floor.

# TECHNICAL DATA

## Air Flow, 380...480 Volt Drives

The following table lists heat loss and air flow data for 380...480 Volt drives.

CENTRIPRO AQUAVAR CPC								
Voltage	Phase	NEMA 1 Base Model	Full Load Amps	NORMAL DUTY HORSEPOWER	Frame Size	Heat Loss		Air Flow CFM
						Watts	BTU/HR	
460	3	CPC40061	6.9	3	R1	97	331	26
		CPC40081	8.8	5	R1	127	433	26
		CPC40121	11.9	7.5	R1	172	587	26
		CPC40151	15.4	10	R2	232	792	52
		CPC40231	23	15	R2	337	1150	52
		CPC40311	31	20	R3	457	1560	79
		CPC40381	38	25	R3	562	1918	79
		CPC40451	45	30	R3	667	2276	165
		CPC40591	59	40	R4	907	3096	165
		CPC40721	72	50	R4	1120	3820	165
		CPC40771	77	60	R4	1295	4420	168
		CPC40971	97	75	R4	1440	4915	168
		CPC41251	125	100	R5	1940	6621	239
		CPC41571	157	125	R6	2310	7884	239
		CPC41801	180	150	R6	2810	9590	239
		CPC42451	245	200	R7	3850	13144	319
		CPC43161	316	250	R7	6850	23386	319
		CPC43681	368	300	R8	6850	23386	721
		CPC44141	414	350	R8	7850	26800	721
		CPC44861	486	400	R8	7850	26800	721
CPC45261	526	450	R8	7600	25946	721		
CPC46021	602	500	R8	8100	27653	721		
CPC46451	645	550	R8	9100	31067	721		

# TECHNICAL DATA

## Air Flow, 208...240 Volt Drives

The following table lists heat loss and air flow data for 208...240 Volt drives.

CENTRIPRO AQUAVAR CPC								
Voltage	Phase	NEMA 1 Base Model	Full Load Amps	NORMAL DUTY HORSEPOWER	Frame Size	Heat Loss		Air Flow CFM
						Watts	BTU/HR	
230	1	CPC20171	8.5	2	R1	161	551	26
		CPC20241	12	3	R2	227	776	52
		CPC20311	15.5	5	R2	285	373	52
		CPC20461	23	7.5	R3	420	1434	79
		CPC20591	29.5	10	R3	536	1829	79
		CPC20881	44.0	15	R4	786	2685	165
		CPC21141	57.0	20	R4	1014	3463	165
		CPC21431	71.5	25	R6	1268	4431	238
		CPC21781	89.0	30	R6	1575	5379	238
		CPC22211	110.5	40	R6	1952	6666	238
		CPC22481	124.0	50	R6	2189	7474	238
230	3	CPC20121	11.8	3	R1	116	404	26
		CPC20171	16.7	5	R1	161	551	26
		CPC20241	24.2	7.5	R2	227	776	52
		CPC20311	30.8	10	R2	285	373	52
		CPC20461	46.2	15	R3	420	1434	79
		CPC20591	59.4	20	R3	536	1829	79
		CPC20751	74.8	25	R4	671	2290	165
		CPC20881	88.0	30	R4	786	2685	165
		CPC21141	114.0	40	R4	1014	3463	165
		CPC21431	143.0	50	R6	1268	4431	238
		CPC21781	178.0	60	R6	1575	5379	238
		CPC22211	221.0	75	R6	1952	6666	238
				CPC22481	248.0	100	R6	2189

# TECHNICAL DATA

## Dimensions and Weights

### Frames R1-R6

The dimensions and mass for the AQUAVAR depend on the frame size and enclosure type. If unsure of frame size, first, find the "Type" code on the drive labels. Then look up that type code in the "Technical Data" on page 142, to determine the frame size. A complete set of dimensional drawings for AQUAVAR drives is located in the Technical Data section.

### Units with UL Type 1 Enclosures

#### Outside Dimensions

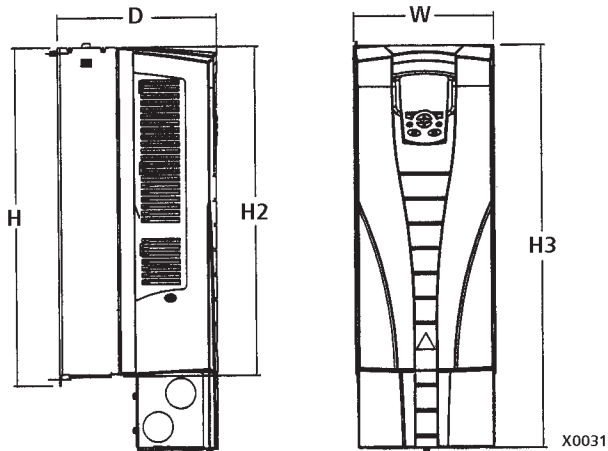

UL Type 1 - Dimensions for each Frame Size												
Ref.	R1		R2		R3		R4		R5		R6	
	mm	in	mm	in	mm	in	mm	in	mm	in	mm	in
<b>W</b>	125	4.9	125	4.9	203	8.0	203	8.0	265	10.4	300	11.8
<b>H</b>	330	13.0	430	16.9	490	19.3	596	23.4	602	23.7	700	27.6
<b>H2</b>	315	12.4	415	16.3	478	18.8	583	23.0	578	22.8	698	27.5
<b>H3</b>	369	14.5	469	18.5	583	23.0	689	27.1	739	29.1	880	34.6
<b>D</b>	212	8.3	222	8.7	231	9.1	262	10.3	286	11.3	400	15.8

**NOTE:** Enclosures are standard NEMA 1, indoor use only.



# TECHNICAL DATA

## Frames R1-R6

### Mounting Dimensions

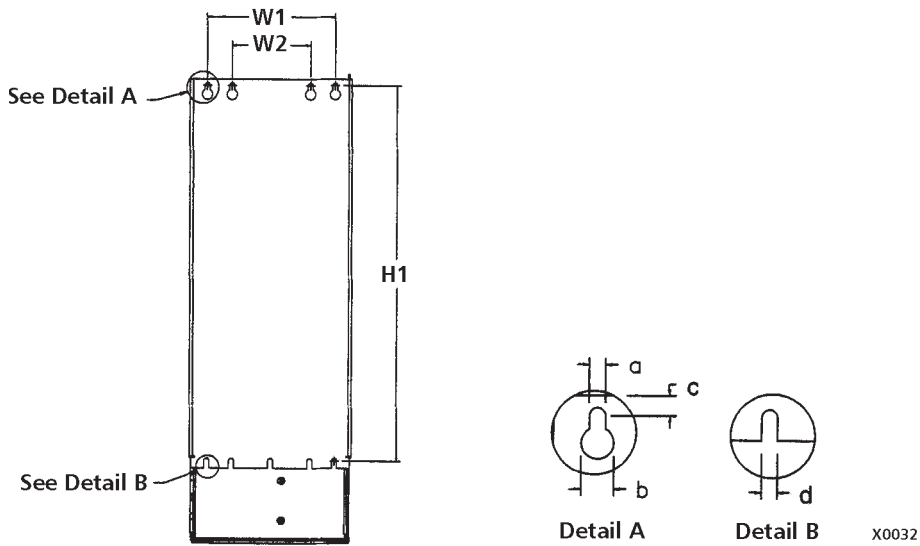

**UL Type 1 - Dimensions for each Frame Size**

Ref.	R1		R2		R3		R4		R5		R6	
	mm	in	mm	in	mm	in	mm	in	mm	in	mm	in
<b>W1*</b>	98.0	3.9	98.0	3.9	160	6.3	160	6.3	238	9.4	263	10.4
<b>W2*</b>	–	–	–	–	98.0	3.9	98.0	3.9	–	–	–	–
<b>H1*</b>	318	12.5	418	16.4	473	18.6	578	22.8	588	23.2	675	26.6
<b>a</b>	5.5	0.2	5.5	0.2	6.5	0.25	6.5	0.25	6.5	0.25	9.0	0.35
<b>b</b>	10.0	0.4	10.0	0.4	13.0	0.5	13.0	0.5	14.0	0.55	14.0	0.55
<b>c</b>	5.5	0.2	5.5	0.2	8.0	0.3	8.0	0.3	8.5	0.3	8.5	0.3
<b>d</b>	5.5	0.2	5.5	0.2	6.5	0.25	6.5	0.25	6.5	0.25	9.0	0.35

\* Center to center dimension.

### Weight

**UL Type 1 - Weight for each Frame Size**

R1		R2		R3		R4		R5		R6	
kg	lb.	kg	lb.	kg	lb.	kg	lb.	kg	lb.	kg	lb.
6.1	13.4	8.9	19.5	14.7	32.4	22.8	50.2	37	82	78	176

# TECHNICAL DATA

## Units with IP 54 / UL Type 12 Enclosures

### Outside Dimensions

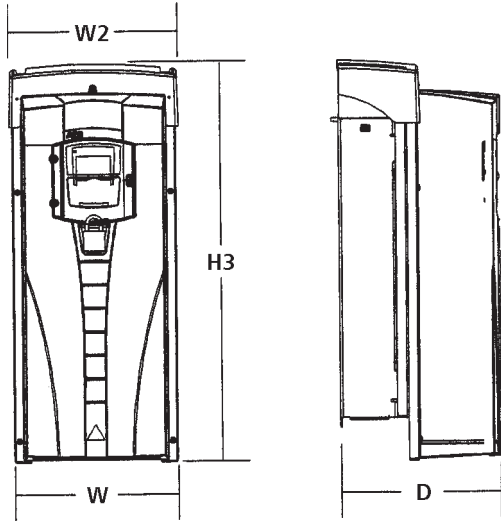

IP 54 / UL Type 12 - Dimensions for each Frame Size												
Ref.	R1		R2		R3		R4		R5		R6	
	mm	in	mm	in	mm	in	mm	in	mm	in	mm	in
<b>W</b>	215	8.5	215	8.5	257	10.1	257	10.1	369	14.5	410	16.1
<b>W2</b>	225	8.9	225	8.9	267	10.5	267	10.5	369	14.5	410	16.1
<b>H3</b>	441	17.4	541	21.3	604	23.8	723	28.5	776	30.5	924	36.4
<b>D</b>	238	9.37	245	9.6	276	10.9	306	12.0	309	12.2	423	16.6

### Mounting Dimensions

Mounting dimensions are the same as for the IP 21 / UL Type 1 Enclosure. See "Mounting Dimensions" on page 144.

### Weight

IP 54 / UL Type 12 - Weight for each Frame Size											
R1		R2		R3		R4		R5		R6	
kg	lb.	kg	lb.	kg	lb.	kg	lb.	kg	lb.	kg	lb.
8.4	18.6	11.5	25.4	18.1	40.0	26.6	58.7	42	93	86	190

# TECHNICAL DATA

## Weights and Dimensions

### Frames R7-R8

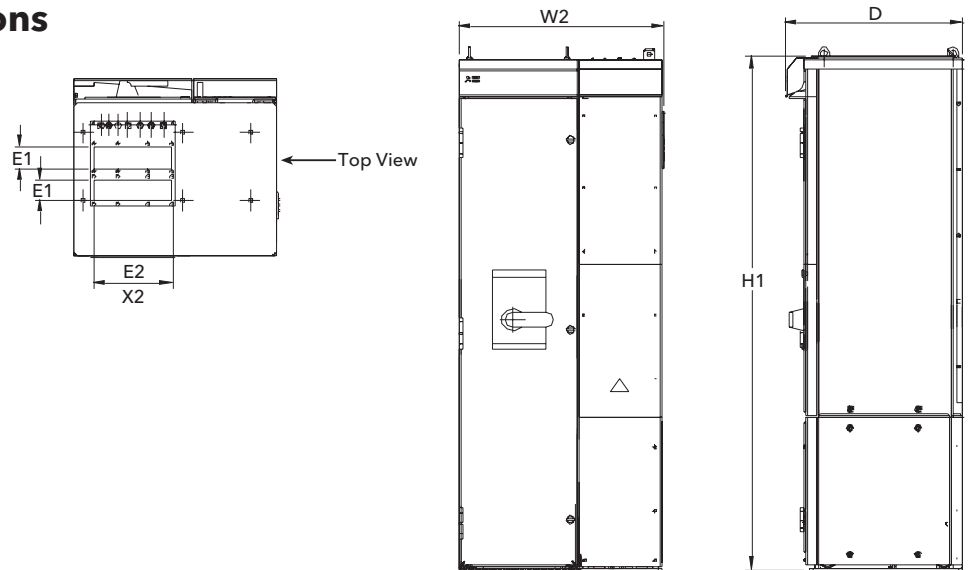

NEMA 1 Enclosure												
Frame	H1		W2		Depth		Weight		E1		E2	
	mm	in	mm	in	mm	in	kg	lb.	mm	in	mm	in
<b>R7</b>	1503	59.17	609	23.98	495	19.49	195	430	92	3.62	250	9.84
<b>R8</b>	2130	83.86	800	31.5	585	23.03	375	827	92	3.62	250	9.84

*Drawing is not for engineering purposes.*

## Degrees of Protection

Available enclosures:

- **IP 21 / UL Type 1 Enclosure.** The site must be free of airborne dust, corrosive gases or liquids, and conductive contaminants such as condensation, carbon dust and metallic particles. Indoor use only.
- **IP 54 / UL Type 12 Enclosure.** This enclosure provides protection from airborne dust and light sprays or splashing water from all directions. Indoor use only.
- **UL Type 3R- Enclosures** are intended for outdoor use to provide a degree of protection from falling rain. Undamaged by the formation of ice on the enclosure. May be cooled by forced air and louvers for vents. This rating is met by placing the drive into a NEMA 3R Enclosure.

Compared to the IP 21 / UL Type 1 Enclosure, the IP 54 / UL Type 12 Enclosure has:

- The same internal plastic shell as the IP 21 Enclosure.
- A different outer plastic cover.
- An additional internal fan to improve cooling.
- Larger dimensions.
- The same rating (does not require a derating).
- Plastic gasketed cover for keypad.

# TECHNICAL DATA

## Ambient Conditions

The following table lists the AQUAVAR environmental requirements.

<b>Ambient Environment Requirements</b>		
	<b>Installation Site</b>	<b>Storage and Transportation in the protective package</b>
<b>Altitude<sup>1</sup></b>	<ul style="list-style-type: none"> <li>• 0...1000 m (0...3,300 ft)</li> <li>• 1000...2000 m (3,300...6,600 ft) if P<sub>N</sub> and I<sub>2</sub> derated 1% every 100 m above 1000 m (300 ft above 3,300 ft).</li> </ul>	
<b>Ambient Temperature<sup>2</sup></b>	<ul style="list-style-type: none"> <li>• -15...40° C (5...104° F)</li> <li>• Max. 50° C (122° F) if P<sub>N</sub> and I<sub>2</sub> derated to 90%.</li> </ul>	-40...70° C (-40...158° F)
<b>Relative humidity</b>	< 95% (non-condensing)	
<b>Contamination levels (IEC 721-3-3)</b>	<ul style="list-style-type: none"> <li>• No conductive dust allowed.</li> <li>• The ACS550 should be installed in clean air according to enclosure classification.</li> <li>• Cooling air must be clean, free from corrosive materials and free from electrically conductive dust.</li> <li>• Chemical gases: Class 3C2</li> <li>• Solid particles: Class 3S2</li> </ul>	<p>Storage</p> <ul style="list-style-type: none"> <li>• No conductive dust allowed.</li> <li>• Chemical gases: Class 1C2</li> <li>• Solid particles: Class 1S2</li> </ul> <p>Transportation</p> <ul style="list-style-type: none"> <li>• No conductive dust allowed.</li> <li>• Chemical gases: Class 2C2</li> <li>• Solid particles: Class 2S2</li> </ul>
<b>Sinusoidal Vibration</b>	<ul style="list-style-type: none"> <li>• Mechanical conditions: Class 3M4 (IEC 60721-3-3)</li> <li>• 2...9 Hz 3.0 mm (0.12 in)</li> <li>• 9...200 Hz 10 m/s<sup>2</sup> (33 ft/s<sup>2</sup>)</li> </ul>	In accordance with ISTA-1A and 1B specifications.
<b>Shock (IEC 68-2-29)</b>	Not allowed	Maximum 100 m/s <sup>2</sup> (330 ft/s <sup>2</sup> ), 11ms (36 ft)
<b>Free Fall<sup>3</sup></b>	Not allowed	<ul style="list-style-type: none"> <li>• 76 cm (30 in), frame size R1</li> <li>• 61cm (24 in), frame size R2</li> <li>• 46 cm (18 in), frame size R3</li> <li>• 31 cm (12 in), frame size R4</li> <li>• 25 cm (10 in), frame size R5</li> <li>• 15 cm (6 in), frame size R6</li> </ul>

(1) Consult factory above 6600' altitude.

(2) Derate drive one HP size from motor for higher temperatures (e.g. motor HP = 10 HP; use 15 HP Aquavar in temperature up to 122° F).

(3) R7-R8 not allowed for free fall any distance.

# TECHNICAL DATA

## Materials

<b>Materials Specifications</b>	
<b>Drive Enclosure</b>	<ul style="list-style-type: none"> <li>• PC/ABS 2.5 mm, color NCS 1502-Y (RAL 90021 / PMS 420 C and 425 C)</li> <li>• Hot-dip zinc coated steel sheet 1.5...2 mm, thickness of coating 100 micrometers.</li> <li>• Cast aluminium AlSi</li> <li>• Extruded aluminium AlSi</li> </ul>
<b>Package</b>	Corrugated board (drives and option modules), expanded polystyrene. Plastic covering of the package: PE-LD, bands PP or steel.
<b>Disposal</b>	<p>The drive contains raw materials that should be recycled to preserve energy and natural resources. The package materials are environmentally compatible and recyclable. All metal parts can be recycled. The plastic parts can either be recycled or burned under controlled circumstances, according to local regulations. Most recyclable parts are marked with recycling marks.</p> <p>If recycling is not feasible, all parts excluding electrolytic capacitors and printed circuit boards can be landfilled. The DC capacitors contain electrolyte and the printed circuit boards contain lead, both of which will be classified as hazardous waste within the EU. They must be removed and handled according to local regulations.</p> <p>For further information on environmental aspects and more detailed recycling instructions, please contact your local recycler.</p>

## Applicable Standards

The drive complies with the following standards. The compliance with the European Low Voltage Directive is verified according to standards EN 50178 and EN 60204-1.

<b>Applicable Standards</b>	
<b>EN 50178 (1997)</b>	Electronic equipment for use in power installations.
<b>EN 60204-1 (1997)</b>	Safety of machinery. Electrical equipment of machines. Part 1: General requirements. Provisions for compliance: The final assembler of the machine is responsible for installing: <ul style="list-style-type: none"> <li>• An emergency-stop device</li> <li>• A supply disconnecting device</li> </ul>
<b>EN 60529: 1991 (IEC 529), IEC 60664-1 (1992)</b>	Degrees of protection provided by enclosures (IP code).
<b>EN 61800-3 (1996) + Amendment A11 (2000)</b>	EMC product standard including specific test methods.
<b>UL 508C</b>	UL Standard for Safety, Power Conversion Equipment, second edition.

# TECHNICAL DATA

## UL Markings

The AQUAVAR is suitable for use on a circuit capable of delivering not more than 65,000 RMS symmetrical amperes, 480 V maximum. The AQUAVAR has an electronic motor protection feature that complies with the requirements of UL 508C. When this feature is selected and properly adjusted, additional overload protection is not required unless more than one motor is connected to the drive or unless additional protection is required by applicable safety regulations.

The drives are to be used in a controlled environment. See section "Ambient Conditions" on page 145 for specific limits.

## Liability Limits

The manufacturer is not responsible for:

- Any costs resulting from a failure if the installation, commissioning, repair, alteration or ambient conditions of the drive do not fulfill the requirements specified in the documentation delivered with the unit and other relevant documentation.
- Units subjected to misuse, negligence or accident.
- Units comprised of materials provided or designs stipulated by the purchaser.

In no event shall the manufacturer, its suppliers or subcontractors be liable for special, indirect, incidental or consequential damages, losses or penalties.

If you have any questions concerning your product, please contact the local distributor or CentriPro. The technical data, information and specifications are valid at the time of printing. The manufacturer reserves the right to modifications without prior notice.

# APPENDIX

## PRESSURE TRANSDUCER 300 PSI 4-20 mA

P/N 9K515

(To order sensor with 200 inch (16 ft.) cable, use P/N 9K391)

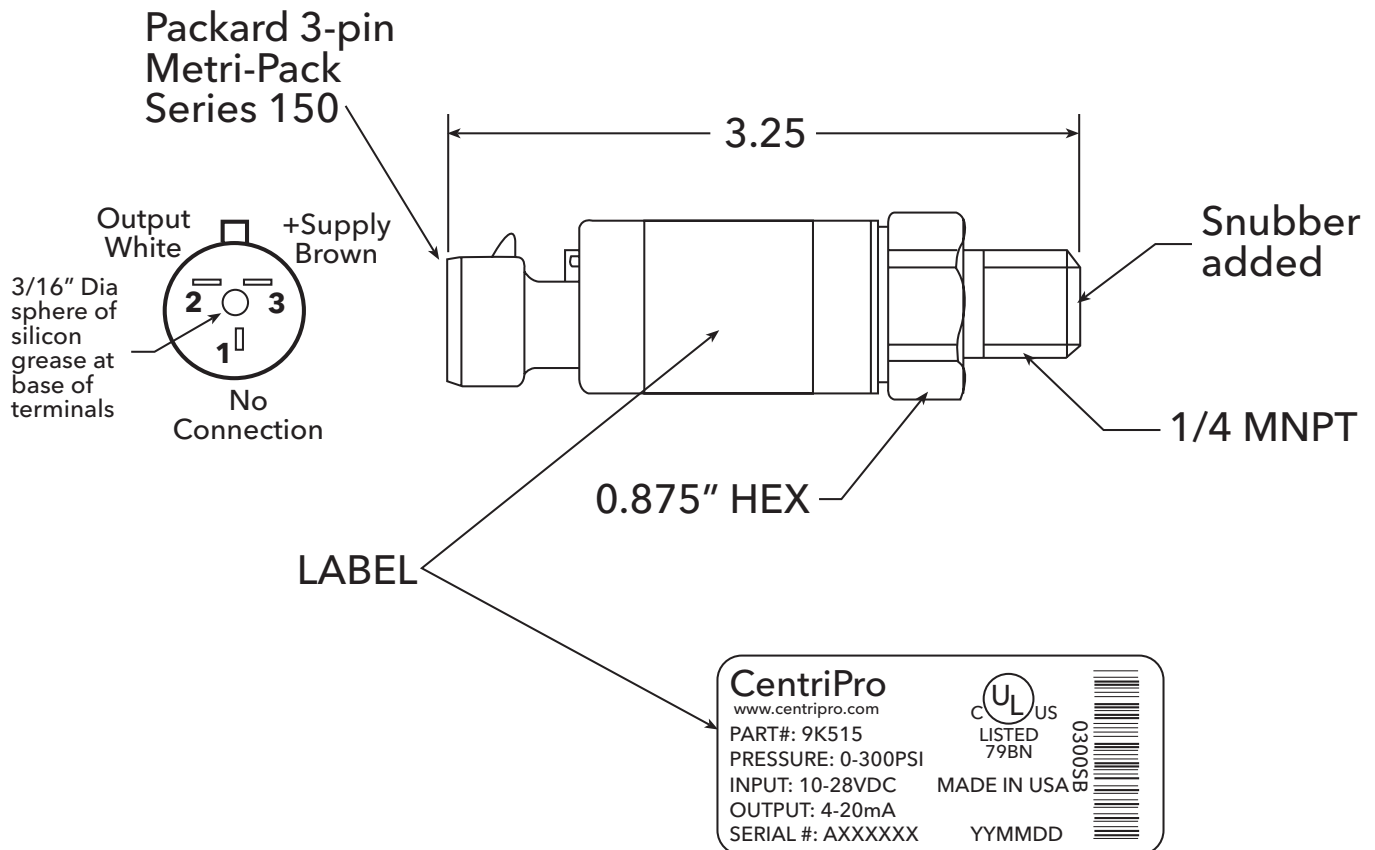

### SPECIFICATIONS

Parameter	Value
Pressure Range	300 PSI
Output (0 - 100%)	4-20 mA
Supply Voltage	10-28 VDC
Burst Pressure Minimum	5x rated
Pressure Overload Maximum	2x rated
Supply Current Maximum	<22mA
Pressure Cycles Minimum	100 million
Accuracy (combined lin/hyst/rep)	< 0.5% BFSL
Zero Offset Maximum	< 1% of FS / °C
Span Tolerance Maximum	< 2% of FS / °C

Parameter	Value
Operating Temp. Range	-40 to 85°C
Compensation Temp. Range	0 to 55°C
Zero Thermal Error Maximum	< .035% of FS
Span Thermal Error Maximum	< .035% of FS
Pressure Port Material	17-4 PH
Housing Material	304 stainless steel
Isolation Voltage Minimum	500VDC
Seal Material	N/A
Listings	UL cUL 508 CE ENG/326

# APPENDIX

## Transducer Data/Specifications

DRAWING  
A00462C

Part No.	K No.	Transducer Part No.	Pressure Range	Cable Part No.
A00462C 1	9K514	A00439C 1	0-150 PSI	A00436C 360
A00462C 2	9K515	A00439C 2	0-300 PSI	
A00462C 3	9K516	A00439C 3	0-500 PSI	
A00462C 4	9K517	A00439C 4	0-1000 PSI	

①

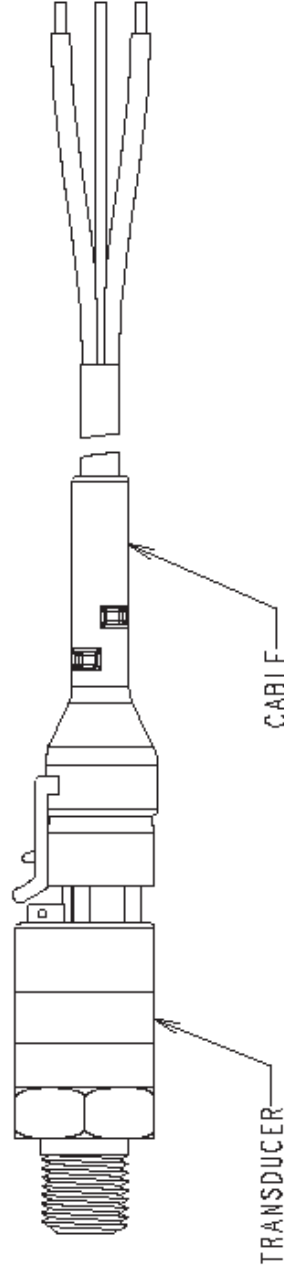

REV	ID	DESCRIPTION	UNITS INCHES	DO NOT SCALE DRAWING	MODEL(S)	SIZES
1	①	ADDED P.N.	GENERAL TOLERANCES UNLESS NOTED OTHERWISE: INCHES: MILLIMETERS: X.XX ± 0.20 X.X ± .50 X.XXX ± .005 X.XX ± .125 ANGLES: ALL ± .5	THIS DRAWING IS THE PROPERTY OF GOLD'S WATER TECHNOLOGY/VALMING. SHEETS FALL IN USE AND SHALL NOT, EXCEPT UPON PRIOR WRITTEN PERMISSION, BE LOANED, REPRODUCED, COPIED, OR USED FOR ANY PURPOSE OTHER THAN THE MANUFACTURE OF ARTICLES FOR GOLD'S WATER TECHNOLOGY/VALMING. PARTS TO BE RETURNED UPON REQUEST.	PART <b>PRESSURE TRANSDUCER CABLE ASSY</b>	ALL
	②	ADDED COLUMN. BL 02/11/04	GEOMETRIC TOLERANCES IN ACCORDANCE WITH ASME Y14.5M-1994 AND APPLICABLE GAIT STANDARDS THIRD ANGLE PROJECTION		APPROVED DATE 9/24/03	ORDER 9/24/03
					DRAWING <b>A00462C</b>	REV 1
					MATERIAL VARIATIONS	SHEET 1 of 1

24-Sep-03

Release Level

Model Rev: 0

Model: A00462C



# APPENDIX

## Transducer Cable Specification

BRN SHLD WHT

STRIP AND TIN .190

2.25 ± .25

A

NOTE: DO NOT CONNECT SHIELD AT THIS END

BRN WHITE

NO CONNECTION

ITEM	MFG	QTY	P/N	DESCRIPTION
1	PACKARD	1	12078090	FEMALE CONNECTOR 3 POSITION
2	PACKARD	2	12103881-L	FEMALE TERMINAL
3	QUABBIN	CHART "A" DIM	02287	CABLE, 2 CONDUCTOR, 18 AWG, BRN WHT, PVC/PVC, GREY JACKET Aluminized polyester foil shield #20 AWG drain wire. Nominal overall dia. 0.233"
4	EMCOM	1	3147300	OVERMOLDING

**REFERENCE**

Coil cable  
6" Dia. &  
Tie-wrap  
2 places

A (ft)	Drawing Number	K No.
100	A00436C 100	9K397
50	A00436C 50	9K398
30	A00436C 30	9K399
16 (standard)	A00436C 16	9K400

NOTE: Not available in 200 feet.

REV	D	DESCRIPTION	UNITS: INCHES	DO NOT SCALE DRAWING
1		ADDED: - VENDOR AND P/N FOR CABLE - COIL & TIE WRAP NOTE - SHIELD DESCRIPTION TO CABLE - 360" SIZE KJH 8/27/03	GENERAL TOLERANCES UNLESS NOTED OTHERWISE: INCHES: MILLIMETERS: X.XX ± .020 X.X ± .50 X.XXX ± .005 X.XX ± .125 ANGLES: ALL ± .5°	THIS DRAWING IS THE PROPERTY OF GOULDS WATER TECHNOLOGY / XYLEM INC. SENECA FALLS, NY, USA AND SHALL NOT BE REPRODUCED OR TRANSMITTED IN ANY FORM OR BY ANY MEANS, ELECTRONIC OR MECHANICAL, INCLUDING PHOTOCOPYING, RECORDING, OR BY ANY INFORMATION STORAGE AND RETRIEVAL SYSTEM, WITHOUT THE WRITTEN PERMISSION OF GOULDS WATER TECHNOLOGY / XYLEM INC. BE USED FOR ANY PURPOSE OTHER THAN THE MANUFACTURE OF ARTICLES FOR GOULDS WATER TECHNOLOGY / XYLEM INC. DWG. TO BE RETURNED UPON REQUEST.
2	5	ADDED K NUMBERS TO CHART TMF 11/3/03	GEOMETRIC TOLERANCES IN ACCORDANCE WITH ASME Y14.5M-1994 AND APPLICABLE GWT STANDARDS THIRD ANGLE PROJECTION	PARALLELISM PERPENDICULARITY ANGULARITY TRUE POSITION RUN OUT BOUNDT (TIR) CONCENTRICITY FLATNESS PROFILE

PART		PRESSURE SENSOR CABLE	
MODEL(S)	AQUAVAR	SIZES	ALL
DRAWN	DATE	APPROVED	DATE
TMF	6/20/03	MDW	6/20/03
CAD	PRO/E	DRAWING	A00436C
PATTERN	N/A	VOLUME	N/A
		SCALE	1:1
		SHEET	1 of 1

**Model Rev: 1**

**Release Level PRE-RELEASE**

**03-Nov-03**

**Model A00436C.**

**Release Level PRE-RELEASE**

**03-Nov-03**

# APPENDIX

## Spare Parts List

Part Number	Description
64732048	Control Panel (Keypad) Connector
CPCCPA	Control Panel (Keypad)
OCAT01	Control Panel Extension Cable 8 ft.
CPCB01	Control Board (OMIO) fits all sizes.
OFAN KIT R1	Fan Kit, R1 Frame Size, Aquavar CPC
OFAN KIT R2	Fan Kit, R2 Frame Size, Aquavar CPC
OFAN KIT R3	Fan Kit, R3 Frame Size, Aquavar CPC
OFAN KIT R4	Fan Kit, R4 Frame Size, Aquavar CPC
OFAN KIT R5	Fan Kit, R5 Frame Size, Aquavar CPC
OFAN KIT R6	Fan Kit, R6 Frame Size, Aquavar CPC
64391615	Fan Kit, R7 Frame Size, Aquavar CPC
64391658	Fan Kit, R8 Frame Size, Aquavar CPC
CPCEXTKIT	Control Panel Mounting Kit



I M 1 6 7 R E V 8

### CENTRIPRO LIMITED WARRANTY

This warranty applies to all Aquavar CPC controllers manufactured by Xylem, Inc.

Any part or parts found to be defective within the warranty period shall be replaced at no charge to the dealer during the warranty period. The warranty period shall exist for a period of twenty-four (24) months from date of installation or thirty (30) months from date of manufacture, whichever period is shorter.

A dealer who believes that a warranty claim exists must contact the authorized CentriPro distributor from whom the controller was purchased and furnish complete details regarding the claim. The distributor is authorized to adjust any warranty claims utilizing the CentriPro Customer Service Department.

**The warranty excludes:**

- (a) Labor, transportation and related costs incurred by the dealer;
- (b) Reinstallation costs of repaired equipment;
- (c) Reinstallation costs of replacement equipment;
- (d) Consequential damages of any kind; and,
- (e) Reimbursement for loss caused by interruption of service.

**For purposes of this warranty, the following terms have these definitions:**

- (1) "Distributor" means any individual, partnership, corporation, association, or other legal relationship that stands between CentriPro and the dealer in purchases, consignments or contracts for sale of the subject controllers.
- (2) "Dealer" means any individual, partnership, corporation, association, or other legal relationship which engages in the business of selling or leasing controllers to customers.
- (3) "Customer" means any entity who buys or leases the subject controllers from a dealer. The "customer" may mean an individual, partnership, corporation, limited liability company, association or other legal entity which may engage in any type of business.

**THIS WARRANTY EXTENDS TO THE DEALER ONLY.**



Xylem Inc.  
2881 East Bayard Street Ext., Suite A  
Seneca Falls, NY 13148  
Phone: (800) 453-6777  
Fax: (888) 322-5877  
www.centripro.com

CentriPro and Aquavar are trademarks of Xylem Inc. or one of its subsidiaries.  
© 2012 Xylem Inc. IM167 Revision 8 December 2013