

SPD PLUS

Centrifugal Pump Controller

Quick Start Guide



Overview

The installation of the SPD PLUS adjustable speed drive follows the outline below.

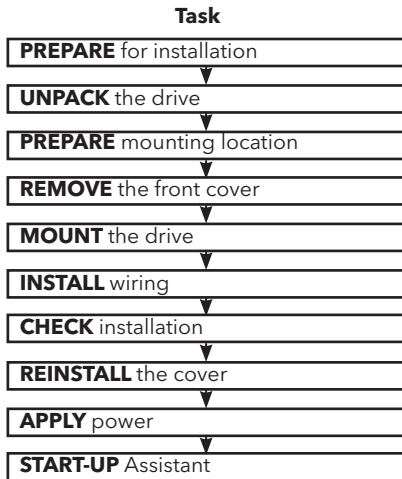

Application

This guide provides a quick reference for installing SPD PLUS drives having a standard enclosure (NEMA 1).

NOTE: This guide does not provide detailed installation, safety or operational instructions. See the Installation Operation Manual for complete information.

Prepare for Installation

WARNING! The Aquavar should ONLY be installed by a qualified electrician.

Check

- Motor Compatibility - Motor type, nominal current, frequency and voltage range must match drive specifications (3 phase motor only).
- Suitable Environment - Drive requires heated, indoor controlled environment that is suitable for the selected enclosure below 122° F (50° C).
- Wiring - Follow local codes for wiring and fusing requirements. Refer to NEC, Local, State or Municipal codes.

Refer to the Installation Operation Manual and confirm that all preparations are complete.

Tools Required

Screwdrivers, wire stripper, tape measure, mounting screws or bolts, and drill.
Use the following chart to interpret the type code found on the drive label.

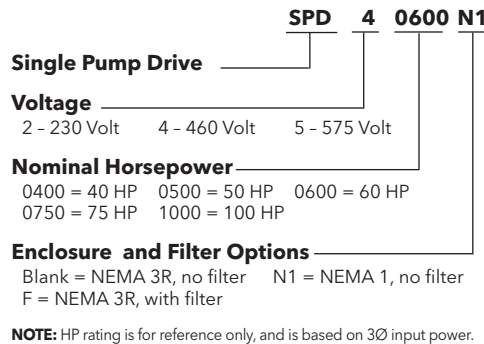

Collect Motor Data

Collect the following data from the motor nameplate for later use in the Aquavar startup:

- Voltage _____
- Nominal Motor Current _____
- Nominal Frequency _____
- Nominal Speed _____
- Nominal Power _____

Unpack the Drive

NOTE: Lift the SPD PLUS by its chassis and not by its cover.

1. Unpack the drive.
2. Check for any damage and notify the shipper immediately if damaged components are found.

3. Check the contents against the order and the shipping label to verify that all parts have been received.

Prepare the Mounting Location

The drive requires a smooth, vertical, solid surface, free from heat and moisture, with free space for air flow - 200 mm (8 in.) above and below, and 25 mm (1 in.) around the sides of the drive.

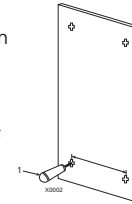

1. Mark the mounting points.
2. Drill the mounting holes.

Remove the Front Cover

1. Remove the control panel (display), if attached.
2. Loosen the captive screw at the top.
3. Pull near the top to remove the cover.

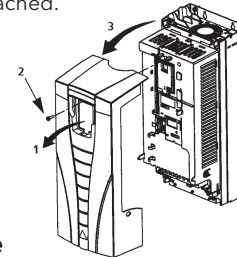

Mount the Drive

1. Position the SPD PLUS and use screws or bolts to securely tighten all four corners.
2. Attach a warning sticker in the appropriate language on the inside plastic shell.

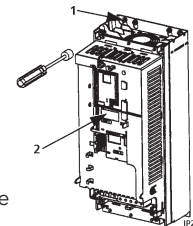

Install the Wiring (copper only)

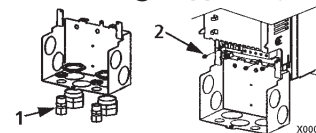

1. Install thin-wall conduit clamps (not supplied) in the conduit/gland box.
2. Install conduit/gland box.

Wiring Power

1. Connect conduit runs to box.
2. Route input power and motor wiring through conduits.

3. Strip wires.
4. Connect power, motor and ground wires to the drive terminals. See "Power Supply and Wiring" in the instruction manual.

Frame Sizes R1...R4

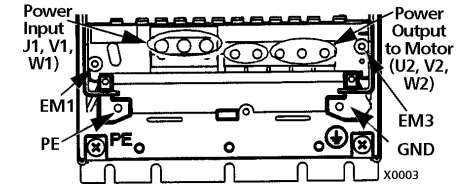

* Single phase input power must use U1, V1 and PE for wiring.

WARNING! For floating networks remove screws at EM1 and EM3 on Frame Sizes R1...R4.

Frame Size R5

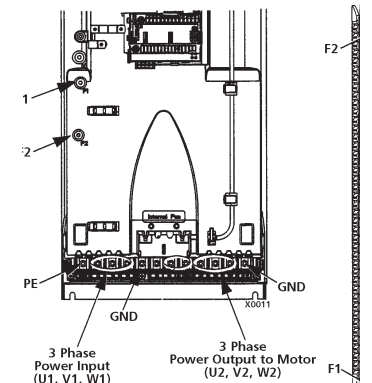

Frame Size R6

WARNING! For floating networks remove screws at F1 and F2 on Frame Sizes R5 or R6.

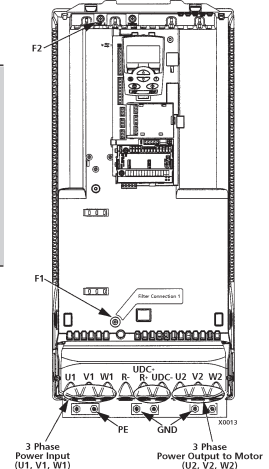

Wiring the Transducer

1. Route the transducer cable through the conduit.
2. Strip the transducer cable sheathing and twist the screen wire.
3. Connect the screen wire of the transducer to terminal X1-1.
4. Connect the power supply wire of the transducer (red or brown) to terminal X1-10.
5. Connect analog output wire from the transducer (white or black) to X1-5. See chart in next column.
6. Install the conduit/gland box cover (1 screw).

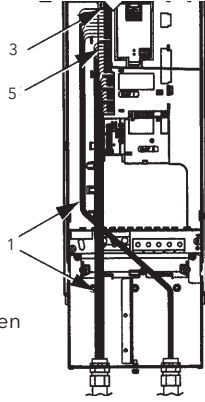

¹ Digital input impedance 1.5 kΩ. Maximum voltage for digital inputs is 30 V.

Check Installation

Before applying power, perform the following checks.

√	Check
	Environment conforms to specifications.
	The drive is mounted securely.
	Proper cooling space around the drive.
	Motor and driven equipment are ready for start.
	Floating networks: Internal RFI filter disconnected.
	Drive is properly grounded, with pump/motor.
	Input power (mains) voltage matches the drive nominal input voltage.
	The input power (mains) terminals, U1, V1, W1, are connected and tightened as specified.
	The input power (mains) fuses / mains switch installed.
	The motor terminals, U2, V2, W2, are connected and tightened as specified.
	Motor cable is routed away from other cables.
	NO power factor compensation capacitors are connected to the motor cable.
	Control terminals are wired and tightened as specified.
	NO tools or foreign objects (such as drill shavings) are inside the drive.
	NO alternate power source for the motor is connected - no input voltage is applied to the output of the drive.

Reinstall the Cover

1. Align the cover and slide it on.
2. Tighten the captive screw.
3. Reinstall the control panel.

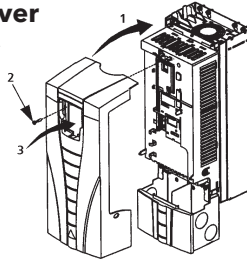

Apply Power

Always reinstall the front cover before turning power on.



WARNING! The SPD PLUS will start up automatically at power up, if the external run command is on.

1. Apply input power.
When power is applied to the SPD PLUS, the green LED comes on.

NOTE! Before increasing motor speed, check that the motor is running in the desired direction.

Start-Up

Run the Start-Up Assistant to configure the motor and system parameters. If this is the first time the drive has been powered, the display will prompt the user if they would like to run the Start-Up Assistant. Select Yes to run the Start-Up Assistant. If this is not the first time the drive has been powered, follow the steps below:

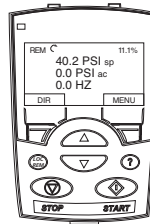

1. From the Main Screen press MENU to enter the MENU screen.
2. Select QUICKSTART
3. Select Start-Up
4. Follow the menu prompts to configure the drive.

NOTE! For common parameters and menu items, use the Help Key (?) to display descriptions. If you encounter Alarms or Faults, use the Help Key or refer to the Diagnostic section of the instruction manual.

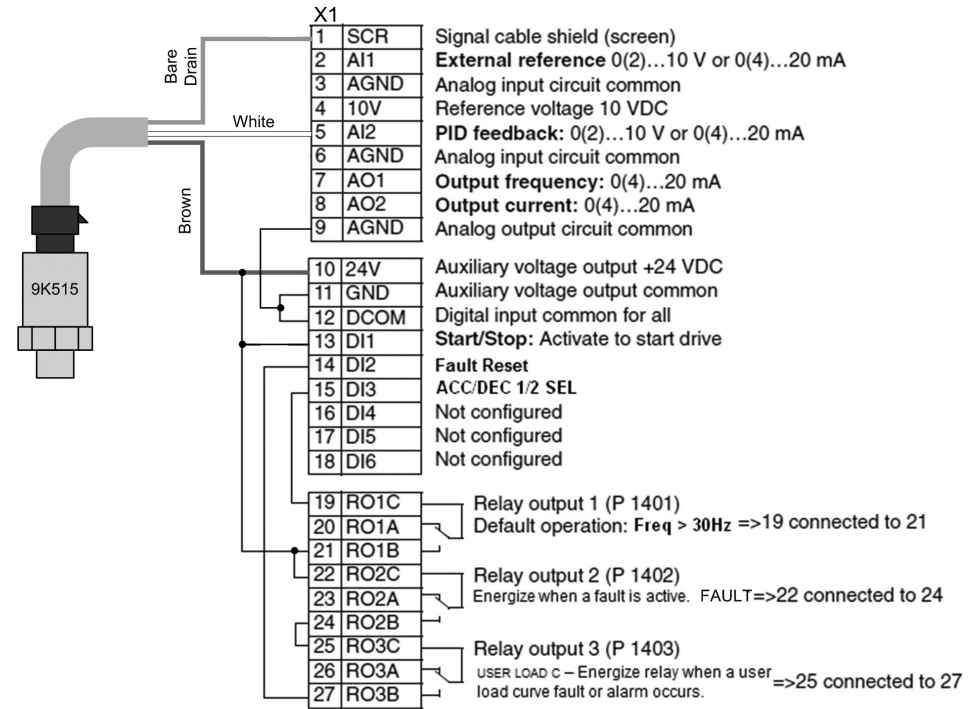

Identification		RELAY OUTPUTS RO4 TO RO6	
1	RO4C	Relay output Default operation: Started	[Symbol]
2	RO4A		
3	RO4B		
4	RO5C	Relay output Default operation: Running	[Symbol]
5	RO5A		
6	RO5B		
7	RO6C	Relay output Default operation: Fault	[Symbol]
8	RO6A		
9	RO6B		

Jumper setting

