

Installation,
Operation, and
Maintenance Manual

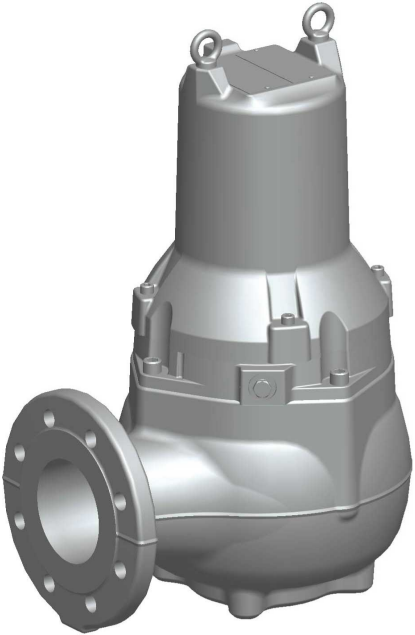

GK, GV (8202, 8202X)

Table of Contents

Introduction and Safety	3
Introduction.....	3
Safety.....	3
Safety terminology and symbols.....	3
Environmental safety.....	4
User safety.....	5
Ex-approved products.....	6
Product warranty.....	7
Transportation and Storage	8
Inspect the delivery.....	8
Inspect the package.....	8
Inspect the unit.....	8
Transportation guidelines.....	8
Precautions.....	8
Position and fastening.....	8
Lifting.....	8
Temperature ranges for transportation, handling and storage.....	9
Handling at freezing temperature.....	9
Unit in as-delivered condition.....	9
Lifting the unit out of liquid.....	10
Storage guidelines.....	10
Storage location.....	10
Long-term storage.....	10
Product Description	11
Pump design.....	11
Parts: standard version	11
Parts: Ex-version	12
Monitoring Equipment.....	13
Optional sensors.....	13
The data plate.....	13
Approvals.....	15
Installation	16
Install the pump.....	16
Authority regulation.....	16
Fasteners.....	16
Install with guide rail.....	17
Install with stand.....	18
Make the electrical connections.....	19
General precautions.....	19
Requirements.....	19
Cables.....	20
Earthing (Grounding).....	20
Connect the motor cable to the pump.....	20
Connect the motor cable to the starter and monitoring equipment.....	21
Cable charts.....	21
Check the impeller rotation.....	30
Operation	31
Precautions.....	31

Distance to wet areas.....	31
Noise level.....	31
Start the pump.....	31
Maintenance.....	33
Precautions.....	33
Maintenance guidelines.....	33
Torque values.....	33
Change the oil.....	34
Empty the oil.....	34
Fill with oil.....	35
Service the pump.....	36
Inspection.....	36
Major overhaul.....	37
Service in case of alarm.....	38
Replace the impeller.....	38
Remove the impeller: D, K	38
Install the impeller: D, K	39
Troubleshooting.....	40
Introduction.....	40
The pump does not start.....	40
The pump does not stop when a level sensor is used.....	41
The pump starts-stops-starts in rapid sequence.....	41
The pump runs but the motor protection trips.....	42
The pump delivers too little or no water.....	42
Technical Reference.....	44
Motor data.....	44
Application limits.....	44

Introduction and Safety

Introduction

Purpose of this manual

The purpose of this manual is to provide necessary information for:

- Installation
- Operation
- Maintenance



CAUTION:

Read this manual carefully before installing and using the product. Improper use of the product can cause personal injury and damage to property, and may void the warranty.

NOTICE:

Save this manual for future reference, and keep it readily available at the location of the unit.

Safety



WARNING:

- The operator must be aware of safety precautions to prevent physical injury.
 - Any pressure-containing device can explode, rupture, or discharge its contents if it is over-pressurized. Take all necessary measures to avoid over-pressurization.
 - Operating, installing, or maintaining the unit in any way that is not covered in this manual could cause death, serious personal injury, or damage to the equipment. This includes any modification to the equipment or use of parts not provided by Xylem. If there is a question regarding the intended use of the equipment, please contact a Xylem representative before proceeding.
 - Do not change the service application without the approval of an authorized Xylem representative.
-



CAUTION:

You must observe the instructions contained in this manual. Failure to do so could result in physical injury, damage, or delays.



Safety terminology and symbols

About safety messages

It is extremely important that you read, understand, and follow the safety messages and regulations carefully before handling the product. They are published to help prevent these hazards:

- Personal accidents and health problems
- Damage to the product
- Product malfunction

Hazard levels

Hazard level	Indication
 <p>DANGER:</p>	<p>A hazardous situation which, if not avoided, will result in death or serious injury</p>
 <p>WARNING:</p>	<p>A hazardous situation which, if not avoided, could result in death or serious injury</p>
 <p>CAUTION:</p>	<p>A hazardous situation which, if not avoided, could result in minor or moderate injury</p>
<p>NOTICE:</p>	<ul style="list-style-type: none"> • A potential situation which, if not avoided, could result in undesirable conditions • A practice not related to personal injury

Hazard categories

Hazard categories can either fall under hazard levels or let specific symbols replace the ordinary hazard level symbols.

Electrical hazards are indicated by the following specific symbol:



Electrical Hazard:

These are examples of other categories that can occur. They fall under the ordinary hazard levels and may use complementing symbols:

- Crush hazard
- Cutting hazard
- Arc flash hazard

Environmental safety

The work area

Always keep the station clean to avoid and/or discover emissions.

Waste and emissions regulations

Observe these safety regulations regarding waste and emissions:

- Appropriately dispose of all waste.
- Handle and dispose of the processed liquid in compliance with applicable environmental regulations.
- Clean up all spills in accordance with safety and environmental procedures.
- Report all environmental emissions to the appropriate authorities.



WARNING:

Do NOT send the product to the Xylem manufacturer if it has been contaminated by any nuclear radiation. Inform Xylem so that accurate actions can take place.

Electrical installation

For electrical installation recycling requirements, consult your local electric utility.

Recycling guidelines

Always follow local laws and regulations regarding recycling.

User safety**General safety rules**

These safety rules apply:

- Always keep the work area clean.
- Pay attention to the risks presented by gas and vapors in the work area.
- Avoid all electrical dangers. Pay attention to the risks of electric shock or arc flash hazards.
- Always bear in mind the risk of drowning, electrical accidents, and burn injuries.

Safety equipment

Use safety equipment according to the company regulations. Use this safety equipment within the work area:

- Hard hat
- Safety goggles, preferably with side shields
- Protective shoes
- Protective gloves
- Gas mask
- Hearing protection
- First-aid kit
- Safety devices

NOTICE:

Never operate a unit unless safety devices are installed. Also see specific information about safety devices in other chapters of this manual.

Electrical connections

Electrical connections must be made by certified electricians in compliance with all international, national, state, and local regulations. For more information about requirements, see sections dealing specifically with electrical connections.

Hazardous liquids

The product is designed for use in liquids that can be hazardous to your health. Observe these rules when you work with the product:

- Make sure that all personnel who work with biologically hazardous liquids are vaccinated against diseases to which they may be exposed.
- Observe strict personal cleanliness.

Wash the skin and eyes

Follow these procedures for chemicals or hazardous fluids that have come into contact with your eyes or your skin:

Condition	Action
Chemicals or hazardous fluids in eyes	<ol style="list-style-type: none"> 1. Hold your eyelids apart forcibly with your fingers. 2. Rinse the eyes with eyewash or running water for at least 15 minutes. 3. Seek medical attention.
Chemicals or hazardous fluids on skin	<ol style="list-style-type: none"> 1. Remove contaminated clothing. 2. Wash the skin with soap and water for at least 1 minute. 3. Seek medical attention, if necessary.

Ex-approved products

Follow these special handling instructions if you have an Ex-approved unit.

Personnel requirements

These are the personnel requirements for Ex-approved products in potentially explosive atmospheres:

- All work on the product must be carried out by certified electricians and Xylem authorized mechanics. Special rules apply to installations in explosive atmospheres.
- All users must know about the risks of electric current and the chemical and physical characteristics of the gas, the vapor, or both present in hazardous areas.
- Any maintenance for Ex-approved products must conform to international and national standards (for example, IEC/EN 60079-17).

Xylem disclaims all responsibility for work done by untrained and unauthorized personnel.

Product and product handling requirements

These are the product and product handling requirements for Ex-approved products in potentially explosive atmospheres:

- Only use the product in accordance with the approved motor data.
- The Ex-approved product must never run dry during normal operation. Dry running during service and inspection is only permitted outside the classified area.
- Before you start work on the product, make sure that the product and the control panel are isolated from the power supply and the control circuit, so they cannot be energized.
- Do not open the product while it is energized or in an explosive gas atmosphere.
- Make sure that thermal contacts are connected to a protection circuit according to the approval classification of the product, and that they are in use.
- Intrinsically safe circuits are normally required for the automatic level-control system by the level regulator if mounted in zone 0.
- The yield stress of fasteners must be in accordance with the approval drawing and the product specification.
- Do not modify the equipment without approval from an Ex-approved Xylem representative.
- Only use parts that are provided by an Ex-approved Xylem representative.

Guidelines for compliance

Compliance is fulfilled only when you operate the unit within its intended use. Do not change the conditions of the service without the approval of an Ex-approved Xylem representative. When you install or maintain explosion proof products, always comply with the directive and applicable standards (for example, IEC/EN 60079-14).

Minimum permitted liquid level

See the dimensional drawings of the product for the minimum permitted liquid level according to the approval for explosion proof products. If the information is missing on the dimensional drawing, the product must be fully submerged. Level-sensing equipment must be installed if the product can be operated at less than the minimum submersion depth.

Monitoring equipment

For additional safety, use condition-monitoring devices. Condition-monitoring devices include but are not limited to the following:

- Level indicators
- Temperature detectors

Product warranty

Coverage

Xylem undertakes to remedy defects in products from Xylem under these conditions:

- The faults are due to defects in design, materials, or workmanship.
- The faults are reported to an local sales and service representative within the warranty period.
- The product is used only under the conditions described in this manual.
- The monitoring equipment incorporated in the product is correctly connected and in use.
- All service and repair work is done by Xylem authorized personnel.
- Genuine Xylem parts are used.
- Only Ex-approved spare parts and accessories authorized by an EX-approved Xylem representative are used in Ex-approved products.

Limitations

The warranty does not cover defects caused by these situations:

- Deficient maintenance
- Improper installation
- Modifications or changes to the product and installation made without consulting an Xylem authorized representative
- Incorrectly executed repair work
- Normal wear and tear

Xylem assumes no liability for these situations:

- Bodily injuries
- Material damages
- Economic losses

Warranty claim

Xylem products are high-quality products with expected reliable operation and long life. However, should the need arise for a warranty claim, then contact your local sales and service representative.

Spare parts

Xylem guarantees that spare parts will be available for 15 years after the manufacture of this product has been discontinued.

Transportation and Storage

Inspect the delivery

Inspect the package

1. Inspect the package for damaged or missing items upon delivery.
2. Note any damaged or missing items on the receipt and freight bill.
3. File a claim with the shipping company if anything is out of order.
If the product has been picked up at a distributor, make a claim directly to the distributor.

Inspect the unit

1. Remove packing materials from the product.
Dispose of all packing materials in accordance with local regulations.
2. Inspect the product to determine if any parts have been damaged or are missing.
3. If applicable, unfasten the product by removing any screws, bolts, or straps.
For your personal safety, be careful when you handle nails and straps.
4. Contact your sales representative if anything is out of order.

Transportation guidelines

Precautions



WARNING:

- Stay clear of suspended loads.
 - Observe accident prevention regulations in force.
-

Position and fastening

The unit can be transported either horizontally or vertically. Make sure that the unit is securely fastened during transportation, and cannot roll or fall over.

Lifting



WARNING:

- Crush hazard. The unit and the components can be heavy. Use proper lifting methods and wear steel-toed shoes at all times.
 - Lift and handle the product carefully, using suitable lifting equipment.
 - The product must be securely harnessed for lifting and handling. Use eyebolts or lifting lugs if available.
 - Always lift the unit by its lifting handle. Never lift the unit by the motor cable or by the hose.
 - Do not attach sling ropes to shaft ends.
-

Lifting eyebolts

When lifting eyebolts are used for lifting the unit, the following guidelines apply:

- they always have to be screwed in firmly against the base
- they must be level with each other
- the angle between them must not be greater than 90°

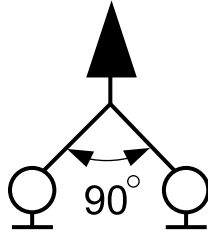

Lifting equipment

Lifting equipment is always required when handling the unit. It must fulfill the following requirements:

- The minimum height (contact your local sales and service representative for information) between the lifting hook and the floor must be sufficient to lift the unit.
- The lifting equipment must be able to hoist the unit straight up and down, preferably without the need for resetting the lifting hook.
- The lifting equipment must be securely anchored and in good condition.
- The lifting equipment must support weight of the entire assembly and must only be used by authorized personnel.
- Two sets of lifting equipment must be used to lift the unit for repair work.
- The lifting equipment must be dimensioned to lift the unit with any remaining pumped media in it.
- The lifting equipment must not be oversized.

NOTICE:

Oversized lifting equipment could cause damage if the unit should stick when being lifted.

Temperature ranges for transportation, handling and storage

Handling at freezing temperature

At temperatures below freezing, the product and all installation equipment, including the lifting gear, must be handled with extreme care.

Make sure that the product is warmed up to a temperature above the freezing point before starting up. Avoid rotating the impeller/propeller by hand at temperatures below the freezing point. The recommended method to warm the unit up is to submerge it in the liquid which will be pumped or mixed.

NOTICE:

Never use a naked flame to thaw the unit.

Unit in as-delivered condition

If the unit is still in the condition in which it left the factory - all packing materials are undisturbed - then the acceptable temperature range during transportation, handling and storage is: -50°C (-58°F) to +60°C (+140°F).

If the unit has been exposed to freezing temperatures, then allow it to reach the ambient temperature of the sump before operating.

Lifting the unit out of liquid

The unit is normally protected from freezing while operating or immersed in liquid, but the impeller/propeller and the shaft seal may freeze if the unit is lifted out of the liquid into a surrounding temperature below freezing.

Units equipped with an internal cooling system are filled with a mixture of water and 30% glycol. This mixture remains a flowing liquid at temperatures down to -13°C (9°F). Below -13°C (9°F), the viscosity increases such that the glycol mixture will lose its flow properties. However, the glycol-water mixture will not solidify completely and thus cannot harm the product.

Follow these guidelines to avoid freezing damage:

1. Empty all pumped liquid, if applicable.
2. Check all liquids used for lubrication or cooling, both oil and water-glycol mixtures, for the presence of water. Change if needed.

Storage guidelines

Storage location

The product must be stored in a covered and dry location free from heat, dirt, and vibrations.

NOTICE:

- Protect the product against humidity, heat sources, and mechanical damage.
 - Do not place heavy weights on the packed product.
-

Long-term storage

If the unit is stored more than 6 months, the following apply:

- Before operating the unit after storage, it must be inspected with special attention to the seals and the cable entry.
- The impeller/propeller must be rotated every other month to prevent the seals from sticking together.

Product Description

Pump design

The pump is submersible, and driven by an electric motor.

Intended use

The product is intended for moving wastewater, sludge, raw and clean water. Always follow the limits that are given in [Application limits](#) (page 44). If there is a question regarding the intended use of the equipment, please contact a local sales and service representative before proceeding.



WARNING:

In explosive or flammable environments, only use Ex- or MSHA-approved pumps.

NOTICE:

Do NOT use the pump in highly corrosive liquids.

The pump is not suitable to pump abrasive solids.

Spare parts

- Modifications to the unit or installation should only be carried out after consulting with Xylem.
- Original spare parts and accessories that are authorized by Xylem are essential for compliance. The use of other parts can invalidate any claims for warranty or compensation. For more information contact your Xylem representative.

Parts: standard version

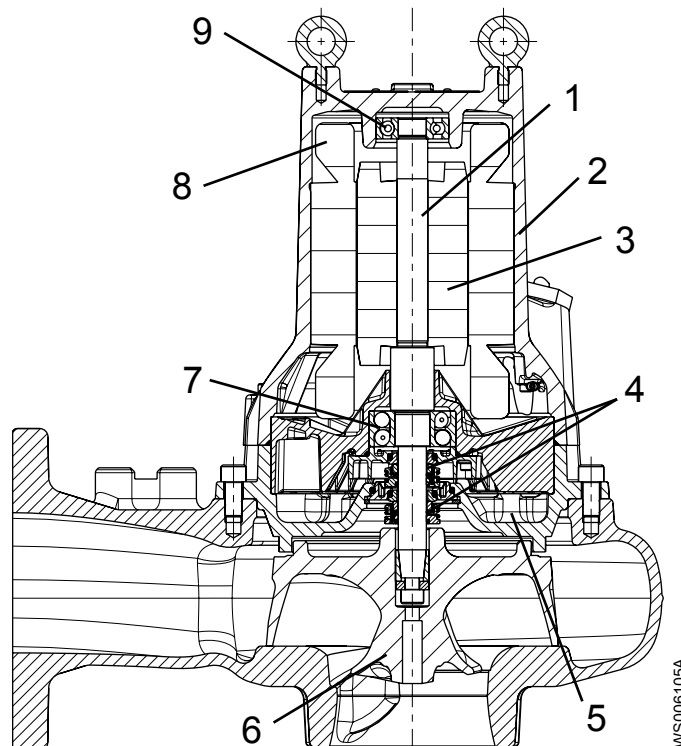

Position	Part	Description
1	Shaft	Stainless steel with an integrated rotor
2	Stator housing	Cooled by ambient liquid
3	Motor	For information about the motor, see Motor data (page 44).
4	Mechanical seal	Type: Mechanical face seal
5	Oil housing	Includes coolant that lubricates and cools the seals; acts as a buffer between the pumped fluid and the electric motor
6	Impeller	D-impeller K-impeller
7	Main bearing	Two-row angular contact ball bearing
8	Thermal contact	If the pump is equipped with a thermal contact, see Monitoring Equipment (page 13).
9	Support bearing	Single-row ball bearing

Parts: Ex-version

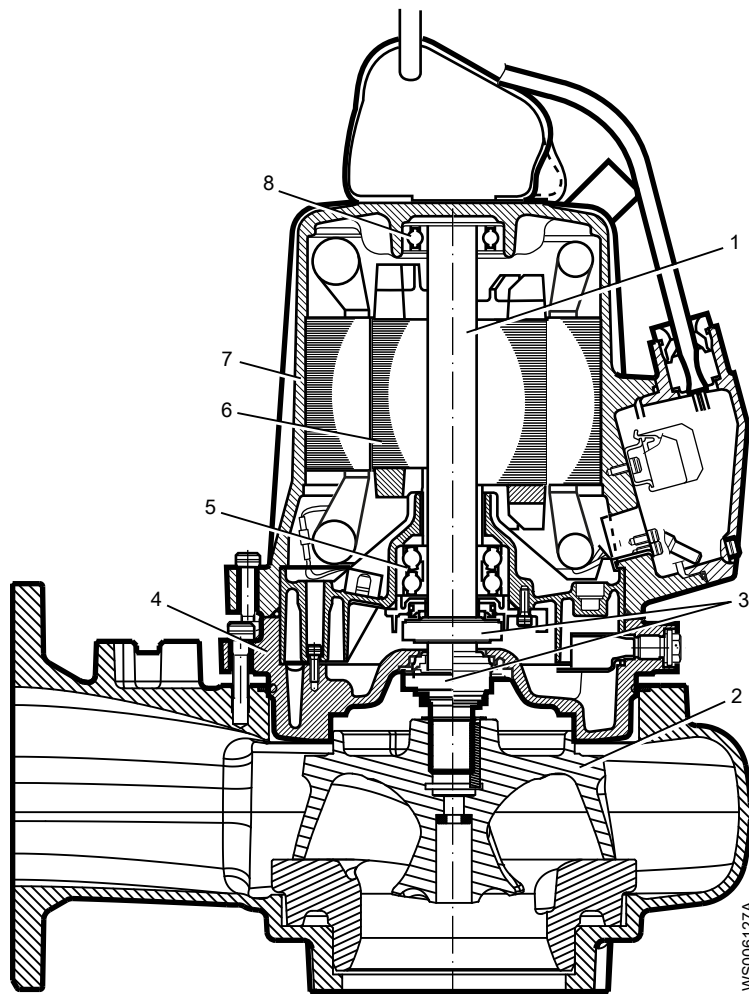

Position	Part	Description
1	Shaft	The shaft is made of stainless steel, with an integrated rotor.

Position	Part	Description
2	Impeller	D-impeller K-impeller
3	Mechanical seals	Type: Mechanical face seal
4	Oil housing	The oil housing includes a coolant that lubricates and cools the seals; the housing acts as a buffer between the pumped fluid and the drive unit.
5	Main bearing	The bearing consisting of a two-row angular contact ball bearing.
6	Motor	For information about the motor, see .Motor data (page 44).
7	Stator housing	The pump is cooled by the ambient liquid/air.
8	Support bearing	The bearing consisting of a single-row ball bearing.

Monitoring Equipment

The following applies to the monitoring equipment of the pump:

- The stator incorporates thermal contacts connected in series that activates the alarm at overtemperature.
- The thermal contacts open at 140°C (285°F).
- Ex-approved pumps must have thermal contacts connected to the control panel.
- The sensors must be connected to either the SMR 311 monitoring equipment or an equivalent equipment.
- The monitoring equipment must be of a design that makes automatic restart impossible.
- Information in the junction box shows if the pump is equipped with optional sensors

Optional sensors

LD LD is a miniature float switch for detection of liquid in the stator housing. Due to its design it is best suited for pumps in a vertical position. The LD sensor is installed in the bottom of the stator housing.

The data plate

The data plate

The data plate is a metal label located on the main body of the pump. The data plate lists key product specifications.

Ex- and MSHA-approved products also have approval plates. They are described below, if applicable.

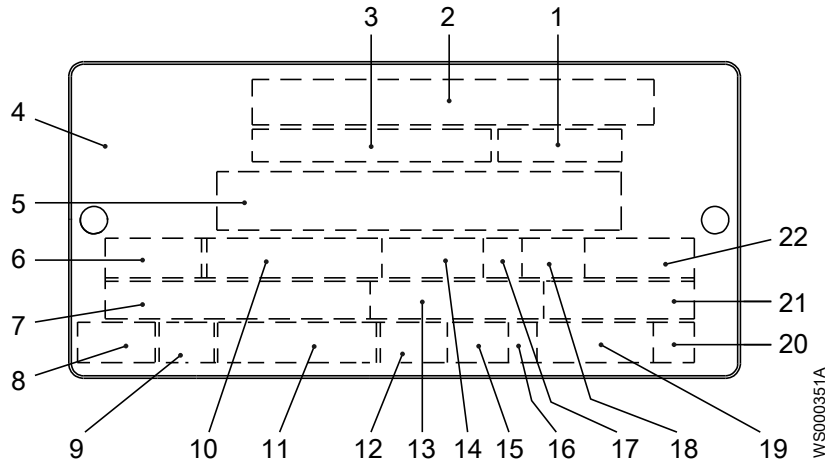

1. Curve code/Propeller code
2. Serial number
3. Product number
4. Country of origin
5. Additional information
6. Phase; type of current; frequency
7. Rated voltage
8. Thermal protection
9. Thermal class
10. Rated shaft power
11. International standard
12. Degree of protection
13. Rated current
14. Rated speed
15. Maximum submergence
16. Direction of rotation: L=left, R=right
17. Duty class
18. Duty factor
19. Product weight
20. Locked rotor code letter
21. Power factor
22. Maximum ambient temperature

The name plate

The name plate is a metal label located on the main body of the pump. This plate lists key product specifications for the branded pump.

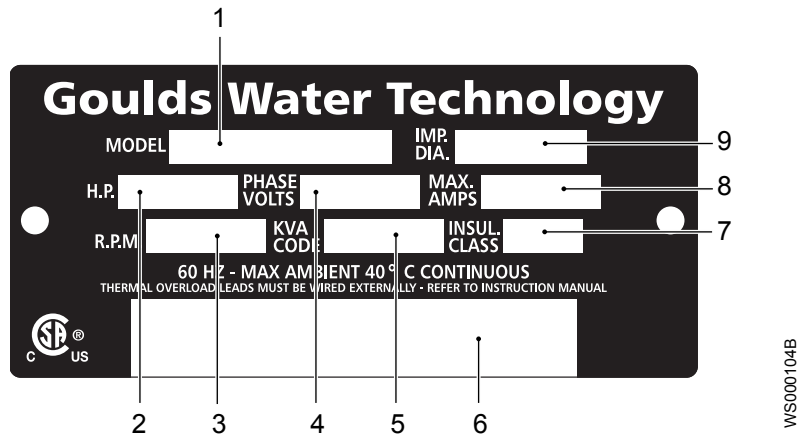

1. Model
2. Horse power
3. R.P.M.
4. Phase Volts
5. KVA code

6. Additional information
7. Insulation class
8. Max. amperes
9. Impeller diameter

Approvals

This section describes the special approvals that explosion-proof products have. For more information, please contact your sales representative.

FM

This illustration describes the approval plate for Factory Mutual (FM) and the information contained in its fields.

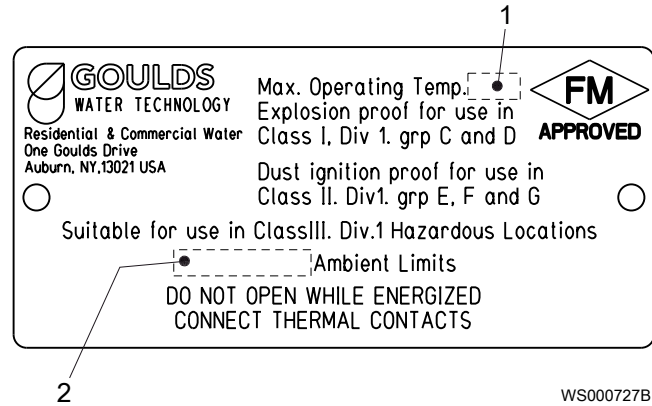

1. Temperature class
2. Maximum ambient temperature

Figure 1: FM approval plate

Installation

Install the pump



DANGER:

Disconnect and lock out electrical power before installing or servicing the unit.



WARNING:

- Note that special rules apply to installation in explosive atmospheres.
 - Make sure that the unit cannot roll or fall over and injure people or damage property.
 - Do not install CSA-approved products in locations that are classified as hazardous in the national electric code, ANSI/NFPA 70-2005.
 - Do not install the starter equipment in an explosive zone unless it is explosion-proof rated.
-



WARNING:

Electrical shock hazard. Check that the cable and cable entry have not been damaged during transport before installing the pump.

NOTICE:

- Do not run the pump dry.
 - Never force piping to make a connection with a pump.
 - Always remove all debris and waste material from the sump, inlet piping, and discharge connection, before you install the pump.
-

These requirements apply:

- Use the pump dimensional drawing in order to ensure proper installation.
- Provide a suitable barrier around the work area, for example, a guard rail.
- Check the explosion risk before you weld or use electric hand tools.
- Always check the impeller rotation before lowering the pump into the pumped liquid.

Authority regulation

Vent the tank of a sewage machine station in accordance with local plumbing codes.

Fasteners



WARNING:

- Only use fasteners of the proper size and material.
 - Replace all corroded fasteners.
 - Make sure that all fasteners are properly tightened and that there are no missing fasteners.
-

Install with guide rail

In the P-installation, the pump is installed on a stationary discharge connection, and operates either completely or partially submerged in the pumped liquid. These requirements and instructions only apply when the installation is made according to the dimensional drawing.

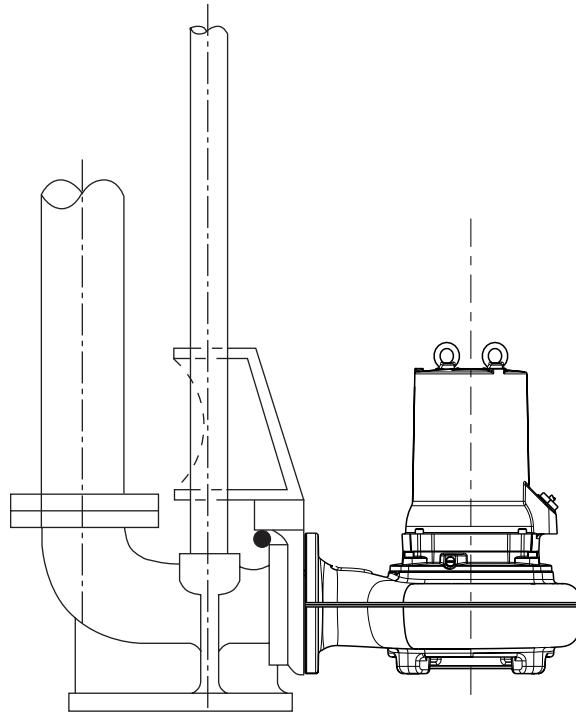

Figure 2: Installation with guide rail

These items are required:

- Guide bars
 - Guide bar bracket for attaching the guide equipment to the access frame or to the upper part of the sump
 - Level regulators or other control equipment for start, stop, and alarm
 - Cable holder for holding the cable and regulating the height of the level regulators
 - Access frame (with covers) to which the upper guide bar bracket and cable holder can be attached
 - Discharge connection for connecting the pump to the discharge line
The discharge connection has a flange which fits the pump casing flange and a bracket for attaching the guide equipment.
 - Fasteners for the discharge connection
 - Anchor bolts
1. Run a cable between the sump and the stator and monitoring equipment.
Make sure that the cable is neither sharply bent, nor pinched.
 2. Install the access frame:
 - a) Place the access frame in position and align it horizontally.
 - b) Grout the frame in place.
 3. Grout the anchor bolts in place.
Be careful when you align and position the discharge connection in relation to the access frame.
 4. Place the discharge connection in position, and tighten the nuts.

5. Install the guide bars:
 - a) Secure the guide bars in the bracket.
 - b) Check that the guide bars are placed vertically. Use a level or a plumb line.
6. Connect the discharge pipe to the discharge connection.
7. Prepare for the level regulator:
 - a) Bolt the cable holder to the access frame.
 - b) Attach the level regulator cable to the cable holder and adjust the height of the level regulator.
 - c) Protect bolts and nuts with a corrosion-preventive compound.
8. Lower the pump along the guide bars.
9. Secure the motor cable:
 - a) Fasten the permanent lifting device to the pump and to the access frame. For example, you can use a stainless-steel lifting chain with shackles.
 - b) Fasten the cable to the cable holder.
Make sure that the cable cannot be sucked into the pump inlet or that it is neither sharply bent, or pinched. Support straps are required for deep installations.
 - c) Connect the motor cable and the starter and monitoring equipment according to the separate instructions.
Make sure that the impeller rotation is correct. For more information, see [Check the impeller rotation](#) (page 30)

Clean all debris from the sump before starting the pump.

Install with stand

In the S-installation, the pump is transportable and intended to operate either completely or partially submerged in the pumped liquid. The pump is equipped with a connection for hose or pipe and stands on a base stand.

These requirements and instructions only apply when the installation is made according to the dimensional drawing. For information about the different installation types, see Parts List.

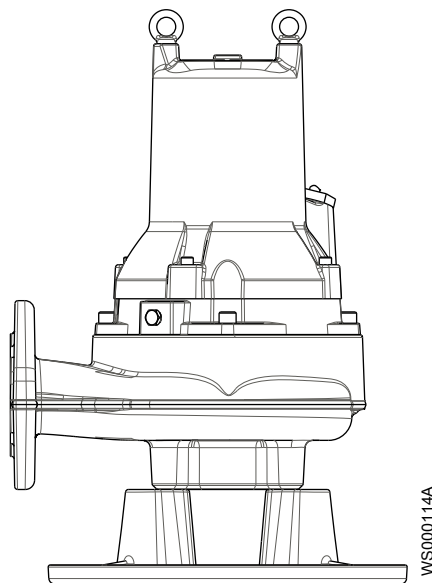

Figure 3: Installation with stand

1. Run the cable so that it has no sharp bends, is not pinched, and cannot be sucked into the pump inlet.
2. Connect the discharge line.

3. Lower the pump into the sump.
4. Place the pump on the base and make sure it cannot fall over or sink.
Alternatively, the pump can be suspended with a lifting chain just above the sump bottom. Make sure that the pump cannot rotate at startup or during operation.
5. Connect the motor cable and the starter and monitoring equipment according to the separate instructions.

Make sure that the impeller rotation is correct. For more information, see [Check the impeller rotation](#) (page 30).

Make the electrical connections

General precautions



Electrical Hazard:

- A certified electrician must supervise all electrical work. Comply with all local codes and regulations.
- Before starting work on the unit, make sure that the unit and the control panel are isolated from the power supply and cannot be energized. This applies to the control circuit as well.
- Leakage into the electrical parts can cause damaged equipment or a blown fuse. Keep the end of the motor cable above the liquid level.
- Make sure that all unused conductors are insulated.
- There is a risk of electrical shock or explosion if the electrical connections are not correctly carried out or if there is fault or damage on the product.



WARNING:

Do not install the starter equipment in an explosive zone unless it is explosion-proof rated.



CAUTION:

If the pump is equipped with automatic level control and/or internal contactor, there is a risk of sudden restart.

Requirements

These general requirements apply for electrical installation:

- The supply authority must be notified before installing the pump if it will be connected to the public mains. When the pump is connected to the public power supply, it may cause flickering of incandescent lamps when started.
- The mains voltage and frequency must agree with the specifications on the data plate. If the pump can be connected to different voltages, then the connected voltage is specified by a yellow sticker close to the cable entry.
- The fuses and circuit breakers must have the proper rating, and the pump overload protection (motor protection breaker) must be connected and set to the rated current according to the data plate and if applicable the cable chart. The starting current in direct-on-line start can be up to six times higher than the rated current.
- The fuse rating and the cables must be in accordance with the local rules and regulations.
- If intermittent operation is prescribed, then the pump must be provided with monitoring equipment supporting such operation.
- If stated on the data plate, then the motor is convertible between different voltages.

- The thermal contacts/thermistors must be in use.
- For FM-approved pumps, a leakage sensor must be connected and in use in order to meet approval requirements.

Cables

These are the requirements to follow when you install cables:

- The cables must be in good condition, not have any sharp bends, and not be pinched.
- The sheathing must not be damaged and must not have indentations or be embossed (with markings, etc.) at the cable entry.
- The cable entry seal sleeve and washers must conform to the outside diameter of the cable.
- The minimum bending radius must not be below the accepted value.
- If using a cable which has been used before, a short piece must be peeled off when refitting it so that the cable entry seal sleeve does not close around the cable at the same point again. If the outer sheath of the cable is damaged, then replace the cable. Contact a local sales and service representative.
- The voltage drop in long cables must be taken into account. The drive unit's rated voltage is the voltage measured at the cable connection point in the pump.

Earthing (Grounding)



Electrical Hazard:

- You must earth (ground) all electrical equipment. This applies to the pump equipment, the driver, and any monitoring equipment. Test the earth (ground) lead to verify that it is connected correctly.
 - If the motor cable is jerked loose by mistake, the earth (ground) conductor should be the last conductor to come loose from its terminal. Make sure that the earth (ground) conductor is longer than the phase conductors. This applies to both ends of the motor cable.
 - Risk of electrical shock or burn. You must connect an additional earth- (ground-) fault protection device to the earthed (grounded) connectors if persons are likely to come into physical contact with the pump or pumped liquids.
-

Connect the motor cable to the pump



CAUTION:

Leakage into the electrical parts can cause damaged equipment or a blown fuse. Keep the end of the motor cable above the liquid level.

For more information about the cable entry, see the Parts list.

1. Only applicable for standard version: Remove the entry gland screw from the stator housing.
This provides access to the closed end splice.
2. Only applicable for Ex-version: Remove the entry gland screw from the entrance cover.
This provides access to the terminal board.
3. Check the data plate to see which connections are required for the power supply.
4. Only applicable for standard version: Arrange the connections on the closed end splices in accordance with the required power supply. in accordance with the required power supply.
5. Only applicable for Ex-version: Arrange the connections on the terminal board in accordance with the required power supply.

6. Connect the mains leads (L1, L2, L3, and earth (ground)) according to applicable cable chart.
The earth (ground) conductor must be 50 mm (2.0 in.) longer than the phase conductors in the junction box of the unit.
7. Make sure that the pump is correctly connected to earth (ground).
8. Make sure that any thermal contacts incorporated in the pump are properly connected to the closed end splices.
9. Make sure that any thermal contacts incorporated in the pump are properly connected to the terminal board.
10. Only applicable for standard version: Install the entry gland screw on the stator housing.
11. Only applicable for Ex-version: Install the entry gland screw on the entrance cover.

Connect the motor cable to the starter and monitoring equipment



WARNING:

Do not install the starter equipment in an explosive zone unless it is explosion-proof rated.

NOTICE:

- Thermal contacts are incorporated in the pump.
 - Thermal contacts must never be exposed to voltages higher than 250 V, breaking current maximum 4 A. It is recommended that they are connected to 24 V over separate fuses to protect other automatic equipment.
-

The single phase pumps must be equipped with a starter which has start and run capacitors.

1. If thermal contacts are included in the pump installation, connect the T1 and T2 control conductors to the monitoring equipment.

NOTICE:

Ex-approved products must always have the thermal contacts connected irrespective of the ambient temperature.

2. Connect the mains leads (L1, L2, L3, and earth [ground]) to the starter equipment.
For information about the phase sequence and the color codes of the leads, see [Cable charts](#) (page 21).
3. Check the functionality of the monitoring equipment:
 - a) Check that the signals and the tripping function work properly.
 - b) Check that the relays, lamps, fuses, and connections are intact.
 Replace any defective equipment.

Cable charts

Description

This topic contains general connection information. It also provides cable charts that show connection alternatives for use with different cables and power supply.

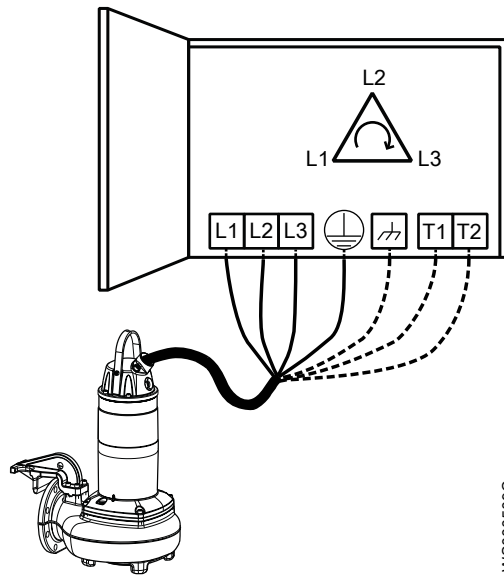

WS000509C

Figure 4: Phase sequence

Connection locations

The figures in this section illustrate how to interpret the connection strip symbols.

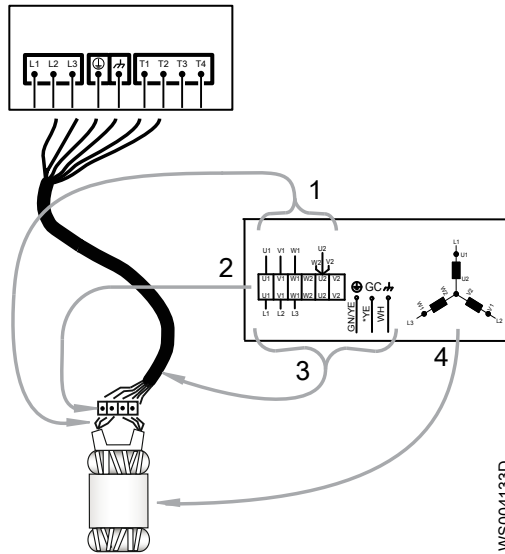

1. Stator leads
2. Terminal board
3. Motor cable leads
4. Stator (internal connection illustrated)

WS004133D

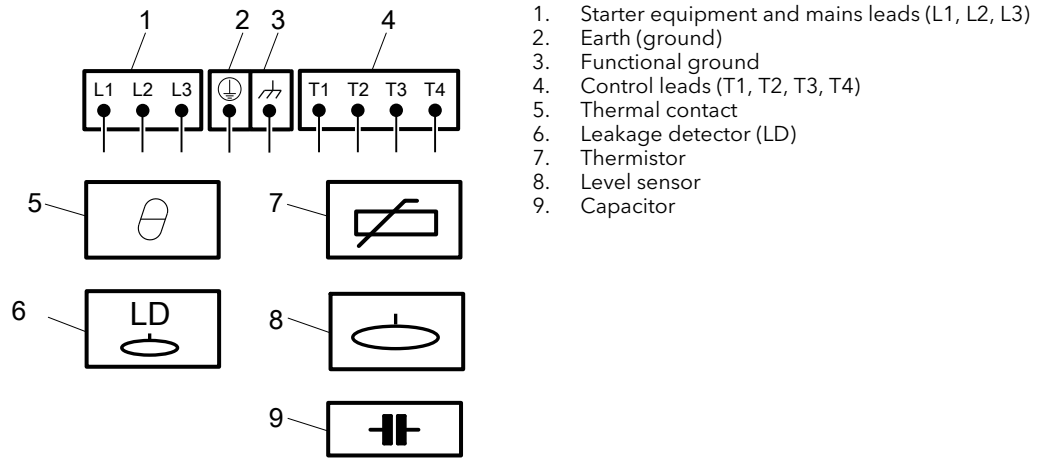

WS004846B

Color code standard

Code	Description
BN	Brown
BK	Black
WH	White
OG	Orange
GN	Green
GNYE	Green-Yellow
RD	Red
GY	Grey
BU	Blue
YE	Yellow

Colors and marking of leads

Motor connection		Mains		SUBCAB 7GX	H07RN-F	SUBCAB 4GX	SUBCAB AWG		
		1 ~	3 ~						
Colors and marking of main leads		1	L1	BK 1	BK 1	BN	RD		
<p>COLOR STANDARD</p> <p>BN = Brown BK = Black WH = White OG = Orange GN = Green GN/YE = Green-Yellow RD = Red GY = Grey BU = Blue YE = Yellow</p> <p>*SUBCAB AWG ** Ground Conductor is stranded around cores GC=Ground Check</p> <p>772 17 05/2</p>		STATOR LEADS		2	L2	BK 2	BK 2	BK	
				3	L3	BK 3	BK 3	GY	WH
					L1	BK 4	BK 4	-	-
					L2	BK 5	BK 5	-	-
					L3	BK 6	BK 6	-	-
						GN/YE	GN/YE	GN/YE	GN/YE
				GC		-	-	-	YE

WS004600B

Figure 5: Motor connection

3-phase connection

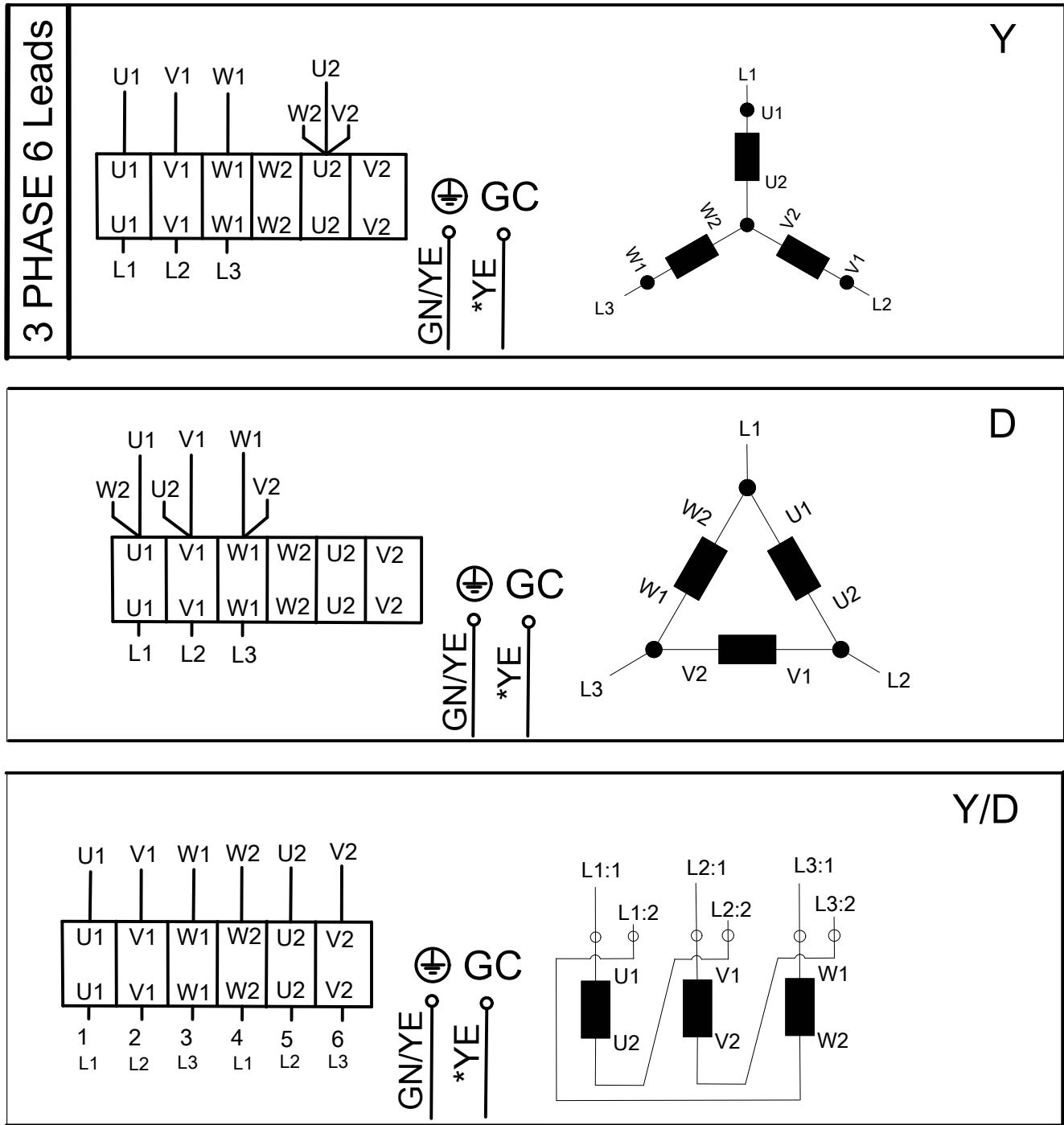

WS004601B

Figure 6: 6 leads

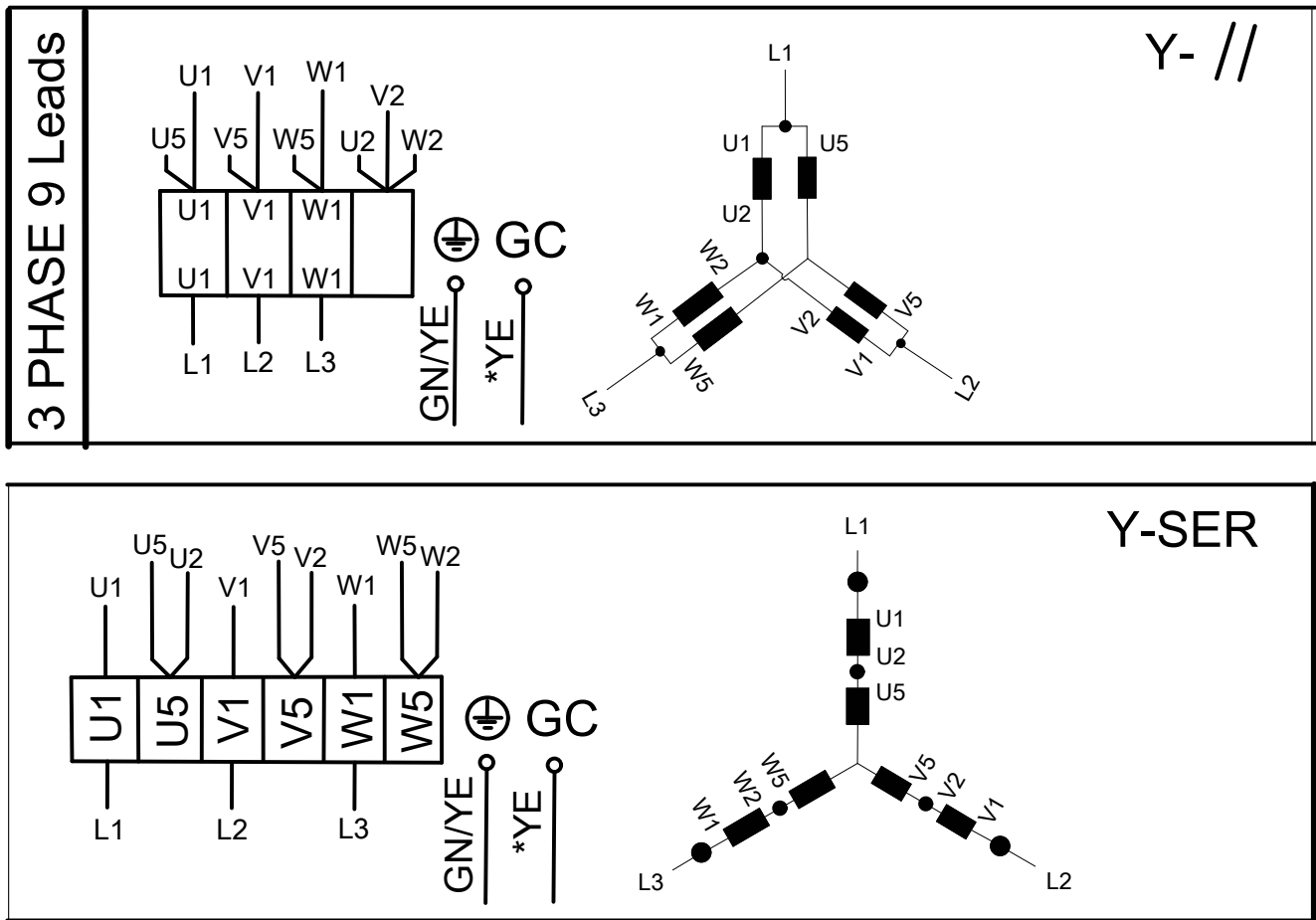

WS004602B

Figure 7: 9 leads

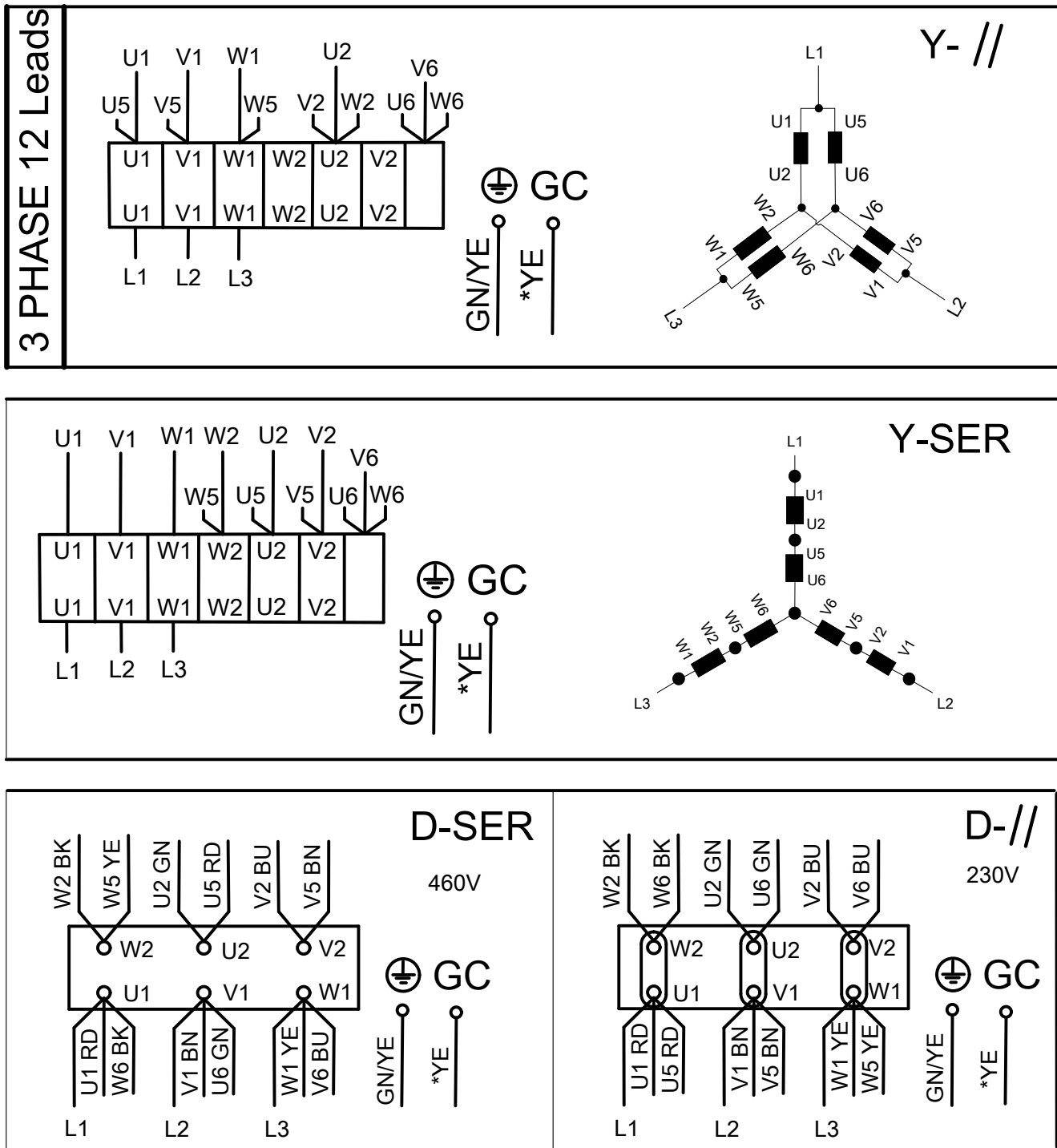

1-phase connection

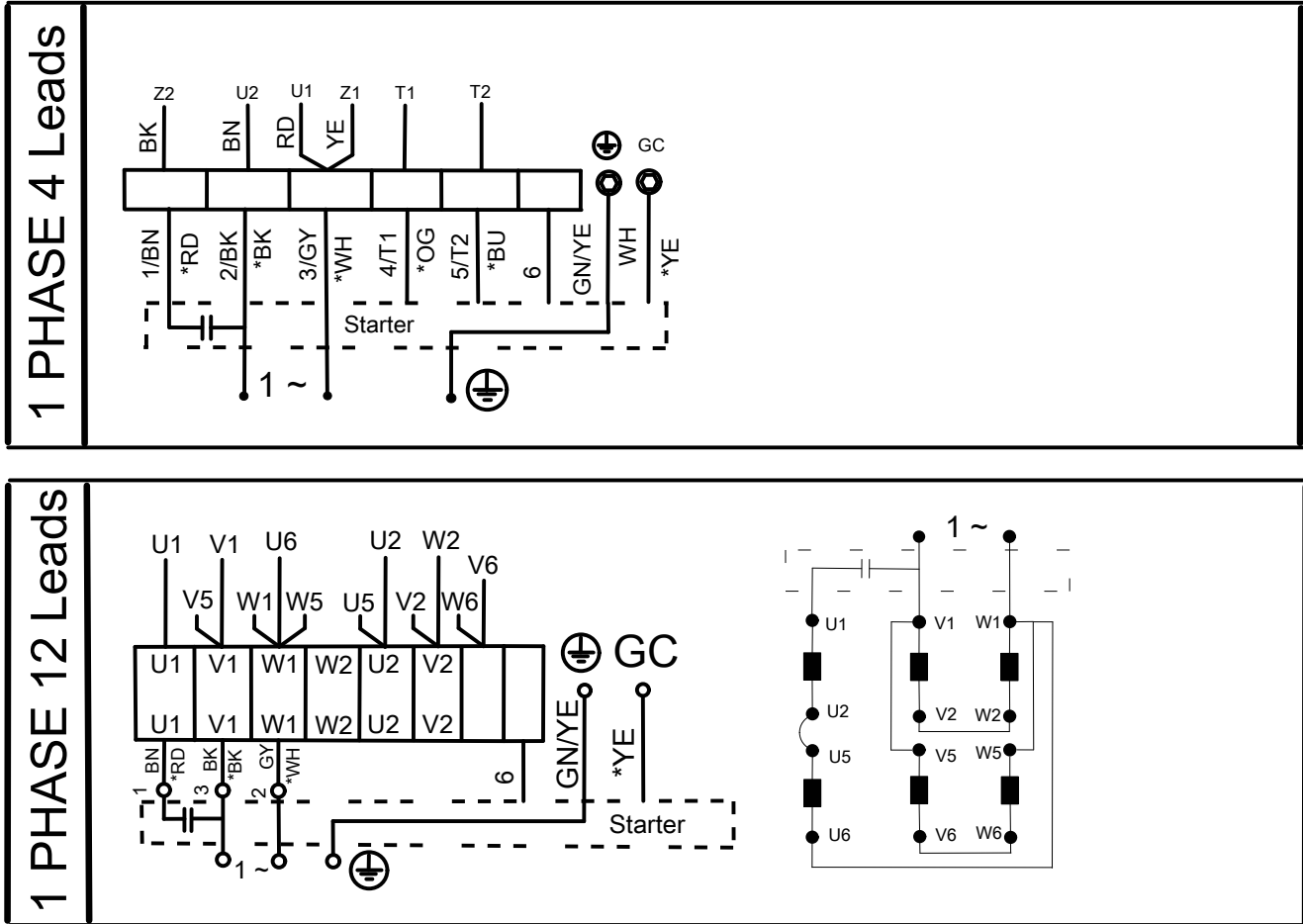

WS004604B

Figure 9: 4 leads, 12 leads

Sensors connection

SENSORS	Control	SUBCAB 4GX/7G	SUBCAB AWG	H07RN-F*
	T1	WH T1	OG	BK 4
	T2	WH T2	BU	BK 5

***IF Y/D-start, sensors not connected**

θ (Thermal Contacts)

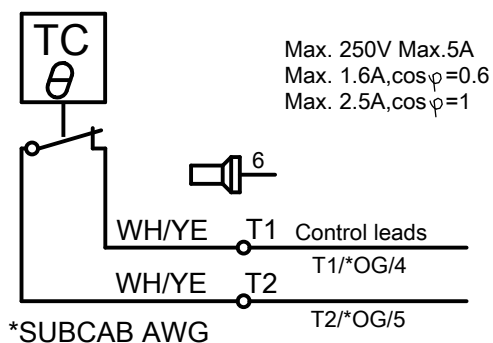

$\theta + LD$

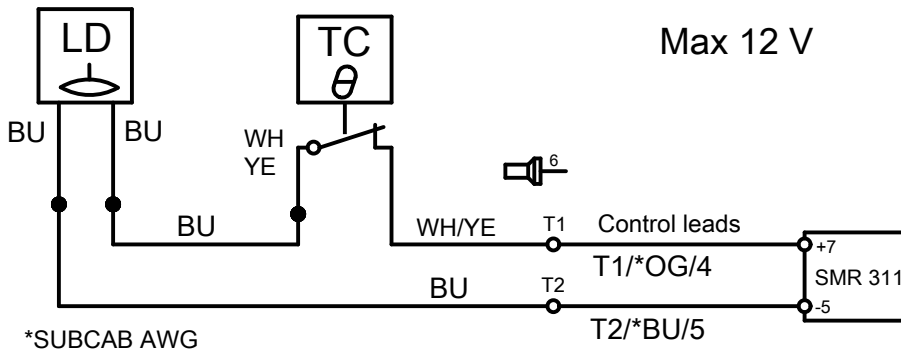

WS004605B

Sensor connection characteristics

The values have a 10 % tolerance.

Sensors	Value (mA)	Definition
LD and thermal contact	0	Overtemperature
	7.8	OK
	36	Leakage

Check the impeller rotation



WARNING:

The starting jerk can be powerful.

1. Start the motor.
2. Stop the motor after a few seconds.
3. Check that the impeller rotates according to this illustration.

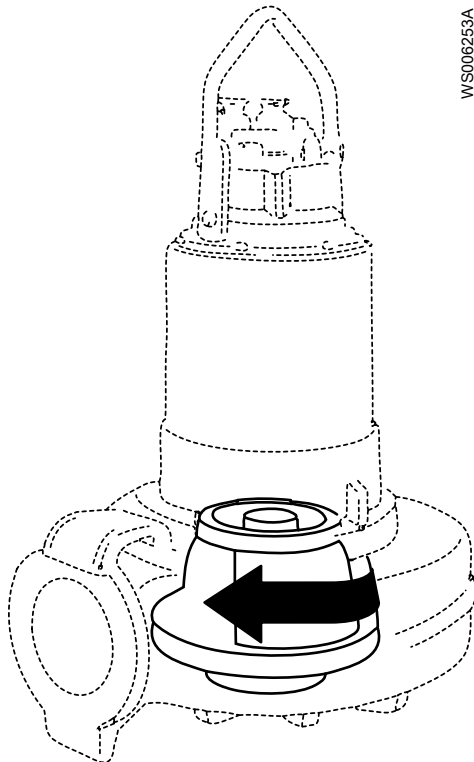

The correct direction of impeller rotation is clockwise when you look at the pump from above.

4. If the impeller rotates in the wrong direction, do one of these steps:
 - If the motor has a 1-phase connection, contact the local sales and service representative.
 - If the motor has a 3-phase connection, transpose two phase leads and do this procedure again.

Operation

Precautions



WARNING:

- Never operate the pump without safety devices installed.
 - Never operate the pump with the discharge valve closed.
 - Make sure you have a clear path of retreat.
 - Never work alone.
-



CAUTION:

If the pump is equipped with automatic level control and/or internal contactor, there is a risk of sudden restart.

Distance to wet areas



Electrical Hazard:

Risk of electrical shock. Make sure no one gets closer than 20 m (65 ft.) to the unit when being in contact with the pumped or mixed liquid.



Electrical Hazard:

Risk of electrical shock. This unit has not been investigated for use in swimming pools. If used in connection with swimming pools special safety regulations apply.

Noise level

NOTICE:

The noise level of the product is lower than 70 dB. However, the noise level of 70 dB may be exceeded in some installations and at certain operating points on the performance curve. Make sure that you understand the noise level requirements in the environment where the pump is installed. Failure to do so may result in hearing loss or violation of local laws.

Start the pump



DANGER:

If you need to work on the pump, make sure that it is isolated from the power supply and cannot be energized.



WARNING:

- Make sure that the unit cannot roll or fall over and injure people or damage property.
 - In some installations, the pump and the surrounding liquid may be hot. Bear in mind the risk of burn injuries.
 - Make sure nobody is close to the unit when it is started. The unit will jerk in the opposite direction of the impeller rotation.
 - During operation the Ex-approved product must be fully submerged.
-

NOTICE:

Make sure that the rotation of the impeller is correct. For more information, see Check the impeller rotation.

1. Check the oil level in the oil housing.
2. Remove the fuses or open the circuit breaker, and check that the impeller can be rotated freely.
3. Conduct insulation test phase to ground. To pass, the value must exceed 5 megohms.
4. Check that the monitoring equipment (if any) works.
5. Start the pump.

Maintenance

Precautions



DANGER:

Disconnect and lock out electrical power before installing or servicing the unit.



WARNING:

- Always follow safety guidelines when working on the product. See [Introduction and Safety](#) (page 3).
- Make sure that the unit cannot roll or fall over and injure people or damage property.
- Rinse the unit thoroughly with clean water before working on the unit.
- Rinse the components in water after dismantling.

Make sure that you follow these requirements:

- Check the explosion risk before you weld or use electrical hand tools.
- Allow all system and pump components to cool before you handle them.
- Make sure that the product and its components have been thoroughly cleaned.
- Do not open any vent or drain valves or remove any plugs while the system is pressurized. Make sure that the pump is isolated from the system and that pressure is relieved before you disassemble the pump, remove plugs, or disconnect piping.

Maintenance guidelines

During maintenance and before reassembly, always remember to perform these tasks:

- Clean all parts thoroughly, particularly O-ring grooves.
- Change all O-rings, gaskets, and seal washers.
- Lubricate all springs, screws, and O-rings with grease.

During reassembly, always make sure that existing index markings are in line.

The reassembled drive unit must always be insulation-tested and the reassembled pump must always be test-run before normal operation.

Torque values

All screws and nuts must be lubricated to achieve correct tightening torque. Screws that are screwed into stainless steel must have the threads coated with suitable lubricants to prevent seizing.

If there is a question regarding the tightening torques, please contact the local sales and service representative.

Screws and nuts

Table 1: Stainless steel, A2 and A4, torque Nm (ft-lbs)

Property class	M4	M5	M6	M8	M10	M12	M16	M20	M24	M30
50	1.0 (0.74)	2.0 (1.5)	3.0 (2.2)	8.0 (5.9)	15 (11)	27 (20)	65 (48)	127 (93.7)	220 (162)	434 (320)
70, 80	2.7 (2)	5.4 (4)	9.0 (6.6)	22 (16)	44 (32)	76 (56)	187 (138)	364 (268)	629 (464)	1240 (915)

Property class	M4	M5	M6	M8	M10	M12	M16	M20	M24	M30
100	4.1 (3)	8.1 (6)	14 (10)	34 (25)	66 (49)	115 (84.8)	248 (183)	481 (355)	–	–

Table 2: Steel, torque Nm (ft-lbs)

Property class	M4	M5	M6	M8	M10	M12	M16	M20	M24	M30
8.8	2.9 (2.1)	5.7 (4.2)	9.8 (7.2)	24 (18)	47 (35)	81(60)	194 (143)	385 (285)	665 (490)	1310 (966.2)
10.9	4.0 (2.9)	8.1 (6)	14 (10)	33 (24)	65 (48)	114 (84)	277 (204)	541 (399)	935 (689)	1840 (1357)
12.9	4.9 (3.6)	9.7 (7.2)	17 (13)	40 (30)	79 (58)	136 (100)	333 (245)	649 (480)	1120 (825.1)	2210 (1630)

Hexagon screws with countersunk heads

For hexagon socket head screws with countersunk head, maximum torque for all property classes must be 80% of the values for property class 8.8 above.

Change the oil

This image shows the plugs that are used to change the oil.

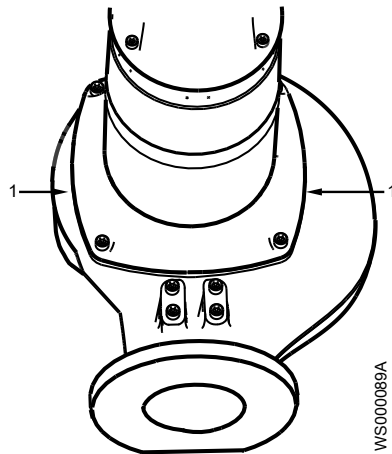

1. Oil plug

Empty the oil



WARNING:

The oil housing may be pressurized. Hold a rag over the oil plug to prevent oil from spraying out.

1. Place the pump in a horizontal position and unscrew the oil plug.
If the pump has a hole with the markings "oil out" it is important that this hole is used for drainage.

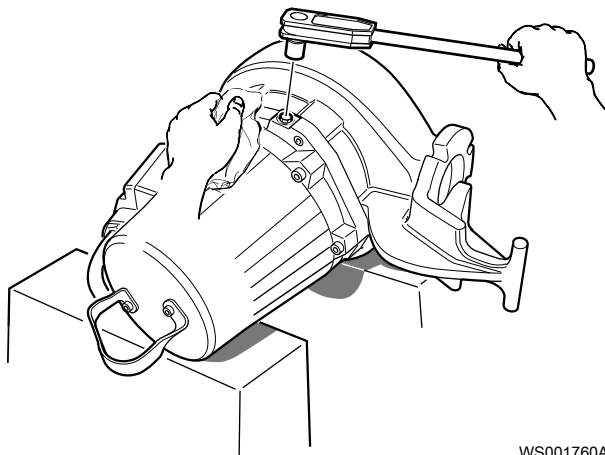

WS001760A

2. Place a container under the pump and turn the pump.
3. Unscrew the other oil plug.

If this hole has the markings "oil in", raise the pump upright for a short period of time during drainage in order to drain all the oil.

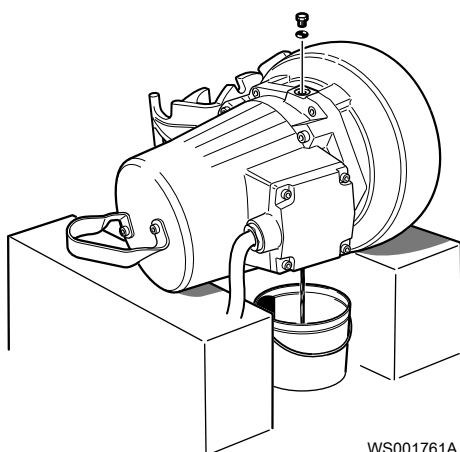

WS001761A

Fill with oil

The oil should be a medical white oil of paraffin type that fulfills FDA 172.878 (a) and viscosity close to VG32.

1. Replace the O-rings of the oil plugs.
2. Refit an oil plug in the hole that faces downwards or is marked "oil out", and tighten.
Tightening torque: 10-40 Nm (7.5-29.5 ft-lbs)
3. Fill with oil through the hole on the opposite side or the hole marked "oil in".

If the hole is marked "oil in", slightly tilt the pump and lower it again in order to fill the pump with the correct quantity.

Quantity: approximately 1.0 L (1.1 qt.)

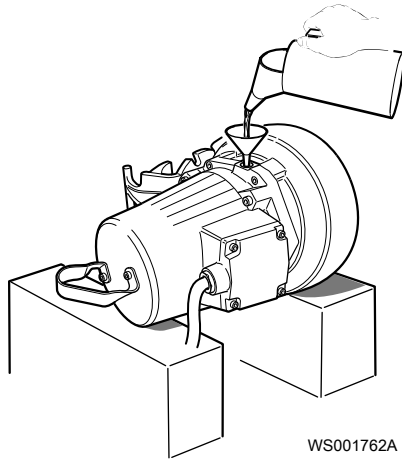

WS001762A

4. Refit the oil plug and tighten.
Tightening torque: 10-40 Nm (7.5-29.5 ft-lbs)

Service the pump

Type of service	Purpose	Inspection interval
Initial inspection	To make a check up of the pump condition by a Xylem authorized service representative and, based on the result and findings from these measures, to determine the intervals for periodical inspection and major overhaul for the specific installation.	Within the first year of operation.
Periodical inspection	To prevent operational interruptions and machine breakdown. Measures to secure performance and pump efficiency are defined and decided for each individual application. It can include such things as impeller trimming, wear part control and replacement, control of zinc-anodes and control of the stator.	Up to every year. Applies to normal applications and operating conditions at media (liquid) temperatures <40°C.
Major overhaul	To secure a long operating lifetime for the product. It includes replacement of key components and the measures taken during an inspection.	Up to every 3 years. This interval apply to normal applications and operating conditions at media (liquid) temperatures <40°C.

NOTICE:

Shorter intervals may be required when the operating conditions are extreme, for example with very abrasive or corrosive applications or when the liquid temperatures exceed 40°C (104°F).

Inspection

Service item	Action
Cable	<ol style="list-style-type: none"> 1. If the outer jacket is damaged, replace the cable. 2. Check that the cables do not have any sharp bends and are not pinched.
Connection to power	Check that the connections are properly tightened.
Electrical cabinets	Check that they are clean and dry.
Impeller	<ol style="list-style-type: none"> 1. Check the impeller clearance. 2. Adjust the impeller, if necessary.
Stator housing	<ol style="list-style-type: none"> 1. Drain all liquid, if any. 2. Check the resistance of the leakage sensor. Normal value approximately 1530 ohms, alarm approximately 330 ohms.
Insulation	<p>Use a megger maximum 1000 V.</p> <ol style="list-style-type: none"> 1. Check that the resistance between the earth (ground) and phase lead is more than 5 megohms. 2. Conduct a phase-to-phase resistance check.
Junction box	Check that it is clean and dry.
Lifting device	Check that local safety regulations are followed.
Lifting handle : Ex-version	<ol style="list-style-type: none"> 1. Check the screws. 2. Check the condition of the lifting handle. 3. Replace if necessary.
Lifting eye bolts: Standard version	<ol style="list-style-type: none"> 1. Check that they are screwed firmly against the base. 2. Check that they are situated on same plane. 3. Check the condition of the lifting eye bolt. 4. Replace if necessary.
O-rings	<ol style="list-style-type: none"> 1. Replace the oil plug O-rings. 2. Replace the O-rings at the entrance or junction cover. 3. Grease the new O-rings.
Personnel safety devices	Check the guard rails, covers, and other protections.
Rotation direction	Check the impeller rotation.
Oil housing	Fill with new oil, if necessary.
Terminal board block/closed end splice	Check that the connections are properly tightened/connected.
Thermal contacts	Normally closed circuit; interval 0–1 ohm.
Voltage and amperage	Check the running values.

Major overhaul

For a major overhaul, take this action in addition to the tasks listed under Inspection.

Service item	Action
Support and main bearing	Replace the bearings with new bearings.
Mechanical seal	Replace with new seal units.

Service in case of alarm

For information about indication values for sensors, see [Sensor connection characteristics](#) (page 29).

Replace the impeller

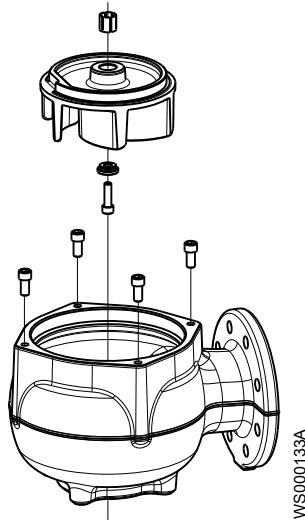

Figure 10: D-impeller

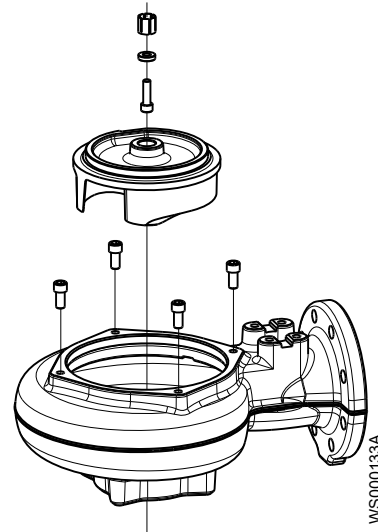

Figure 11: K-impeller

Required tools:

- 8 mm hexagon bit adapter with an extension of at least 125 mm (4.92 in.)
- Impeller puller
 - If applicable, contact your local sales and service representative for correct type and size.
- Rod (wooden or copper) for locking the impeller in place, if applicable.
- Two crowbars, if applicable



WARNING:

- If you fail with the impeller installation, you must redo the installation procedure from the beginning.
- A worn impeller and/or pump housing can have very sharp edges. Wear protective gloves.
- When laying the pump on its side, do not allow the weight of the pump to rest on any portion of the impeller. The impeller must not be allowed to make contact with the concrete floor or other hard and rough surfaces.

Remove the impeller: D, K

1. Remove the pump housing:

- a) Remove the pump housing screws.
- b) Lift off the drive unit from the pump housing.
2. Remove the impeller:
 - a) Place the drive unit horizontally.
 - b) Remove the impeller screw.
 - c) Remove the impeller, the washer, and the conical sleeve.

Install the impeller: D, K

1. Fit the impeller:
 - a) Grease the conical sleeve, the washer, and the impeller screw.
 - b) Fit the conical sleeve, the washer, and the impeller screw to the shaft.
 - c) Fit the impeller.
 - d) Hand-tighten the impeller screw to prevent it from falling off.
2. Fit the pump housing:
 - a) Grease the pump housing screws.
 - b) Raise the drive unit.
 - c) Place the drive unit into the pump housing.
 - d) Tighten the screws in diagonal sequence.
Tightening torque: 57 Nm (42 ft-lbs)
3. Adjust the clearance between the lower edge of the impeller and the pump housing by sliding the impeller on the shaft until it touches the pump housing.
4. Fasten the impeller by tightening the impeller screw.
Tightening torque 65 Nm (48 ft-lbs)
5. K-impeller: Check the clearance (A) between the impeller and the pump housing.
A: 0.2-0.8 mm (0.008-0.032 in.)

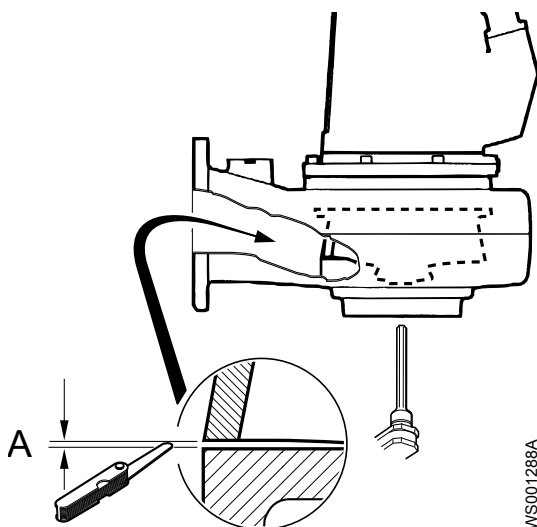

6. Check that the impeller can rotate freely.



CAUTION:

Beware of the pinch point hazard between the rotating impeller and the guide pin.

Troubleshooting

Introduction

Follow these guidelines when troubleshooting the pump:

- Disconnect and lock out the power supply except when conducting checks that require voltage.
- Make sure that no one is near the pump when the power supply is reconnected.
- When troubleshooting electrical equipment, use the following:
 - Universal instrument multimeter
 - Test lamp (continuity tester)
 - Wiring diagram

The pump does not start



WARNING:

Always disconnect and lock out power before servicing to prevent unexpected startup. Failure to do so could result in death or serious injury.

NOTICE:

Do NOT override the motor protection repeatedly if it has tripped. Doing so may result in equipment damage.

Cause	Remedy
An alarm signal has been triggered on the control panel.	Check that: <ul style="list-style-type: none"> • The impeller rotates freely. • The sensor indicators do not indicate an alarm. • The overload protection is not tripped. If the problem still persists: Contact the local sales and service representative.
The pump does not start automatically, but can be started manually.	Check that: <ul style="list-style-type: none"> • The start level regulator is functioning. Clean or replace if necessary. • All connections are intact. • The relay and contactor coils are intact. • The control switch (Man/Auto) makes contact in both positions. Check the control circuit and functions.
The installation is not receiving voltage.	Check that: <ul style="list-style-type: none"> • The main power switch is on. • There is control voltage to the start equipment. • The fuses are intact. • There is voltage in all phases of the supply line. • All fuses have power and that they are securely fastened to the fuse holders. • The overload protection is not tripped. • The motor cable is not damaged.
The impeller is stuck.	Clean:

Cause	Remedy
	<ul style="list-style-type: none"> • The impeller • The sump in order to prevent the impeller from clogging again.

If the problem persists, contact the local sales and service representative.

The pump does not stop when a level sensor is used



WARNING:

Always disconnect and lock out power before servicing to prevent unexpected startup. Failure to do so could result in death or serious injury.

Cause	Remedy
The pump is unable to empty the sump to the stop level.	Check that: <ul style="list-style-type: none"> • There are no leaks from the piping and/or discharge connection. • The impeller is not clogged. • The non-return valve(s) are functioning properly. • The pump has adequate capacity. For information: Contact the local sales and service representative.
There is a malfunction in the level-sensing equipment.	<ul style="list-style-type: none"> • Clean the level regulators. • Check the functioning of the level regulators. • Check the contactor and the control circuit. • Replace all defective items.
The stop level is set too low.	Raise the stop level.

If the problem persists, contact the local Xylem service shop.

The pump starts-stops-starts in rapid sequence

Cause	Remedy
The pump starts due to back-flow which fills the sump to the start level again.	Check that: <ul style="list-style-type: none"> • The distance between the start and stop levels is sufficient. • The non-return valve(s) work(s) properly. • The length of the discharge pipe between the pump and the first non-return valve is sufficiently short.
The self-holding function of the contactor malfunctions.	Check: <ul style="list-style-type: none"> • The contactor connections. • The voltage in the control circuit in relation to the rated voltages on the coil. • The functioning of the stop-level regulator. • Whether the voltage drop in the line at the starting surge causes the contactor's self-holding malfunction.

If the problem persists, contact the local Xylem service shop.

The pump runs but the motor protection trips



WARNING:

Always disconnect and lock out power before servicing to prevent unexpected startup. Failure to do so could result in death or serious injury.

NOTICE:

Do NOT override the motor protection repeatedly if it has tripped. Doing so may result in equipment damage.

Cause	Remedy
The motor protection is set too low.	Set the motor protection according to the data plate and if applicable the cable chart.
The impeller is difficult to rotate by hand.	<ul style="list-style-type: none"> • Clean the impeller. • Clean out the sump. • Check that the impeller is properly trimmed.
The drive unit is not receiving full voltage on all three phases.	<ul style="list-style-type: none"> • Check the fuses. Replace fuses that have tripped. • If the fuses are intact, notify a certified electrician.
The phase currents vary, or they are too high.	Contact the local sales and service representative.
The insulation between the phases and ground in the stator is defective.	<ol style="list-style-type: none"> 1. Use an insulation tester. With a 1000 V DC megger, check that the insulation between the phases and between any phase and ground is > 5 megohms. 2. If the insulation is less: Contact the local sales and service representative.
The density of the pumped fluid is too high.	<p>Make sure that the maximum density is 1100 kg/m³ (9.2 lb/US gal)</p> <ul style="list-style-type: none"> • Change the impeller, or • Change to a more suitable pump. • Contact the local sales and service representative.
There is a malfunction in the overload protection.	Replace the overload protection.

If the problem persists, contact the local Xylem service shop.

The pump delivers too little or no water



WARNING:

Always disconnect and lock out power before servicing to prevent unexpected startup. Failure to do so could result in death or serious injury.

NOTICE:

Do NOT override the motor protection repeatedly if it has tripped. Doing so may result in equipment damage.

Cause	Remedy
The impeller rotates in the wrong direction.	<ul style="list-style-type: none"> • If it is a 3-phase pump, transpose two phase leads. • If it is a 1-phase pump: Contact the local sales and service representative.
One or more of the valves are set in the wrong positions.	<ul style="list-style-type: none"> • Reset the valves that are set in the wrong position. • Replace the valves, if necessary. • Check that all valves are correctly installed according to media flow. • Check that all valves open correctly.
The impeller is difficult to rotate by hand.	<ul style="list-style-type: none"> • Clean the impeller. • Clean out the sump. • Check that the impeller is properly trimmed.
The pipes are obstructed.	Clean out the pipes to ensure a free flow.
The pipes and joints leak.	Find the leaks and seal them.
There are signs of wear on the impeller, pump, and casing.	Replace the worn parts.
The liquid level is too low.	<ul style="list-style-type: none"> • Check that the level sensor is set correctly. • Depending on the installation type, add a means for priming the pump, such as a foot valve.

If the problem persists, contact the local Xylem service shop.

Technical Reference

Motor data

Feature	Description
Motor type	Squirrel-cage induction motor
Frequency	60 Hz
Supply	1-phase or 3-phase
Starting method	Direct on-line
Maximum starts per hour	30 evenly spaced starts per hour
Code compliance	IEC 60034-1
Rated output variation	±10%
Voltage variation without overheating	±10%, provided that it does not run continuously at full load
Voltage imbalance tolerance	2%
Stator insulation class	H (180°C [360°F])

Application limits

Data	Description
Liquid temperature	40°C (104°F) maximum
Liquid density	1100 kg/m ³ (9.2 lb per US gal) maximum
pH of the pumped media (liquid)	5.5-14
Depth of immersion	20 m (65 ft) maximum
Other	For the specific weight, current, voltage, power ratings, and speed of the pump, see the data plate of the pump.

Xylem |'zīləm|

- 1) The tissue in plants that brings water upward from the roots
- 2) A leading global water technology company

We're 12,500 people unified in a common purpose: creating innovative solutions to meet our world's water needs. Developing new technologies that will improve the way water is used, conserved, and re-used in the future is central to our work. We move, treat, analyze, and return water to the environment, and we help people use water efficiently, in their homes, buildings, factories and farms. In more than 150 countries, we have strong, long-standing relationships with customers who know us for our powerful combination of leading product brands and applications expertise, backed by a legacy of innovation.

For more information on how Xylem can help you, go to xylem.com



Xylem Inc.
2881 E. Bayard Street
Seneca Falls, NY 13148
USA
Tel. 1-866-325-4210
Fax 1-888-322-5877
www.xylem.com/brands/gouldswatertechnology

Visit our Web site for the latest version of this document and more information

The original instruction is in English. All non-English instructions are translations of the original instruction.

© 2011 Xylem Inc.

Goulds is a registered trademark of Goulds Pumps, Inc. and is used under license.