

EXPLODED VIEW & PARTS LISTING

Model: NDP-50 Cast Iron-HP
High Pressure Pumps

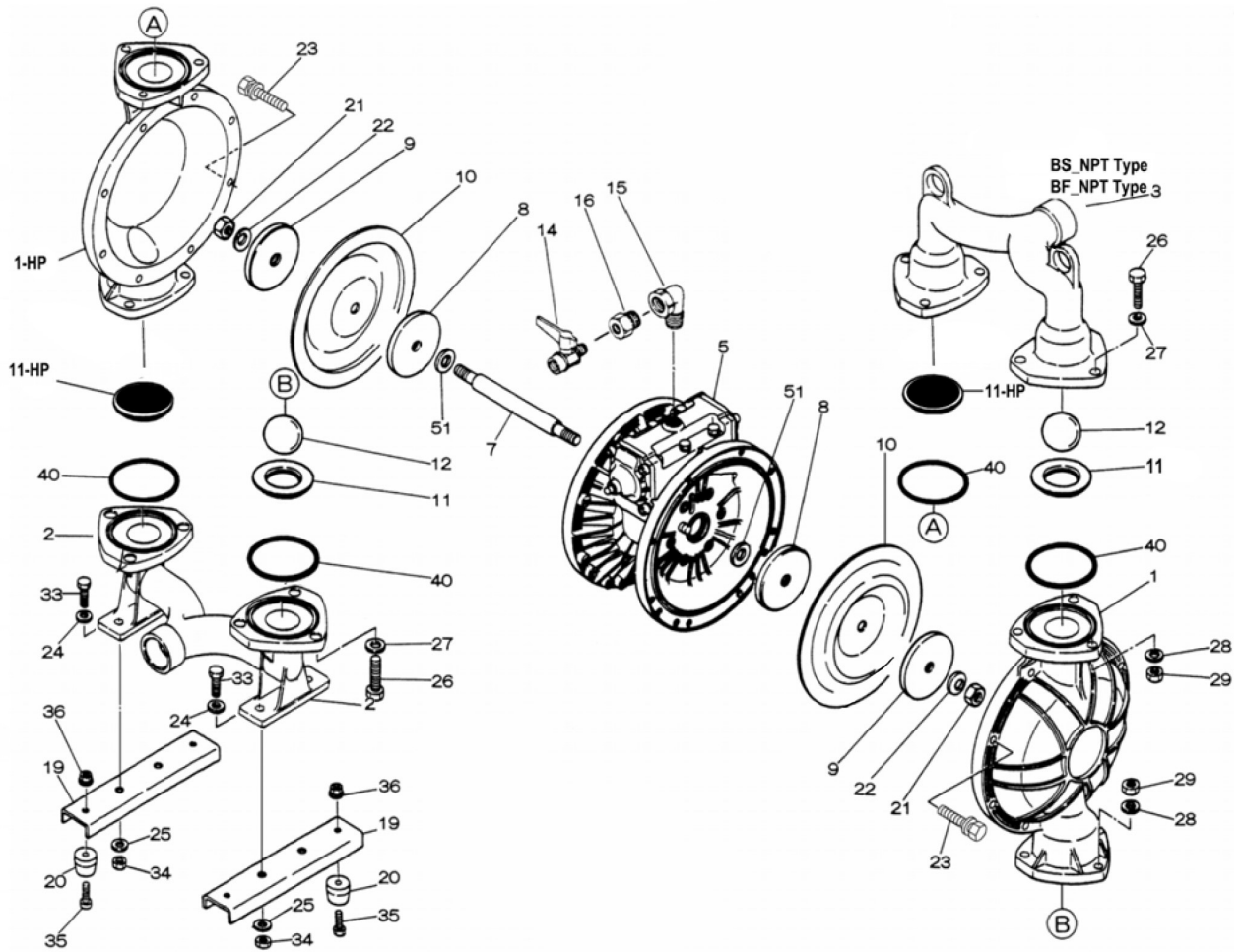

Air Operated Double Diaphragm Pump



Air Operated Double Diaphragm Pump

■ Body Assembly

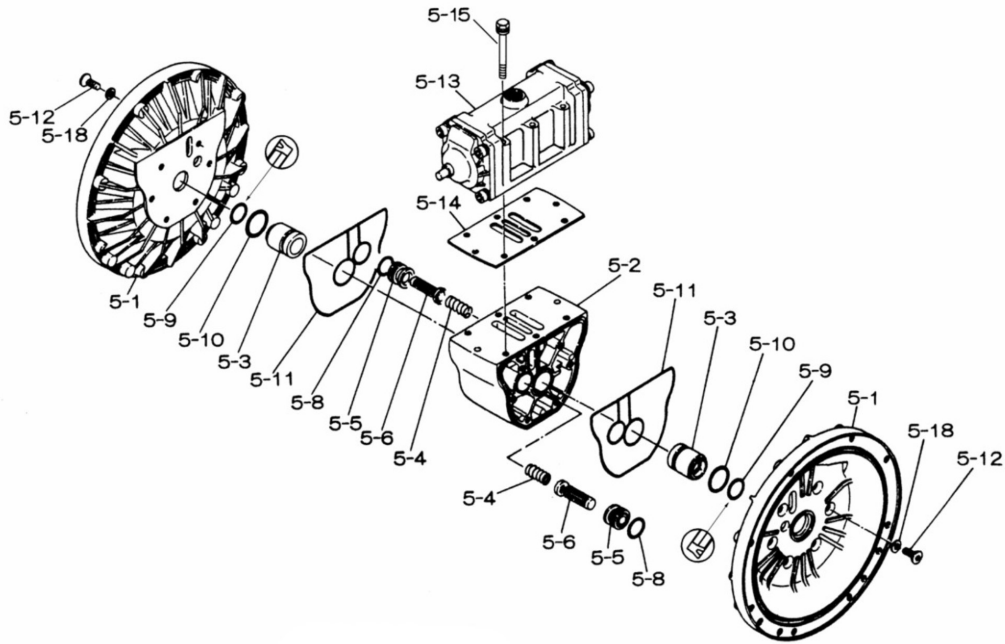

■ Valve Body Assembly

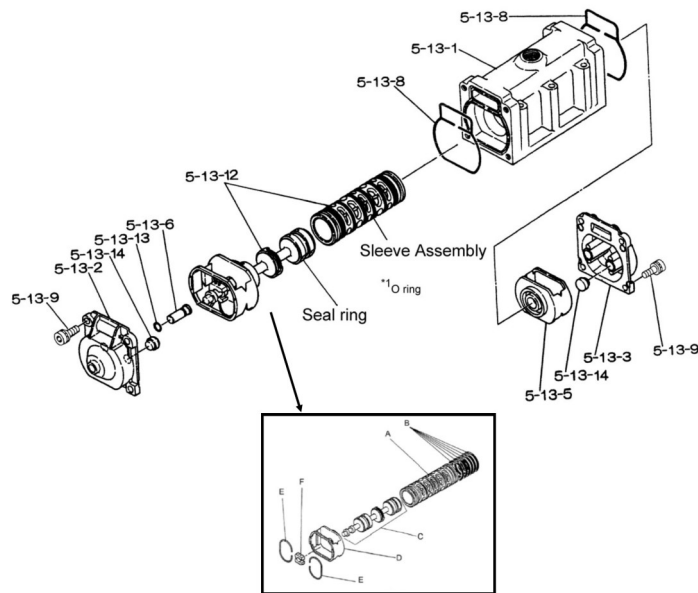

Air Operated Double Diaphragm Pump

	NDP-50BFC-HP	NDP-50BFN-HP	NDP-50BFE-HP	NDP-50BFV-HP	NDP-50BFH-HP	NDP-50BFS-HP			
	852841-HP	852837-HP	852842-HP	852840-HP	852838-HP	852843-HP	Hi-Pressure Pumps		
REF No.	PARTS No.	PARTS No.	PARTS No.	PARTS No.	PARTS No.	PARTS No.	DESCRIPTION	QTY.	REORDER
1	713157	713157	713157	713157	713157	713157	OUT CHAMBER	1	
1-HP	713157-HP	713157-HP	713157-HP	713157-HP	713157-HP	713157-HP	OUT CHAMBER-HP	1	
2	713169	713169	713169	713169	713169	713169	IN MANIFOLD - NPT	1	
3	713166	713166	713166	713166	713166	713166	OUT MANIFOLD - NPT	1	
5	803112-HP	803112-HP	803112-HP	803112-HP	803112-HP	803112-HP	BODY ASSEMBLY	1	
5-1	711934	711934	711934	711934	711934	711934	AIR CHAMBER	2	
5-2	711936-HP	711936-HP	711936-HP	711936-HP	711936-HP	711936-HP	BODY	1	
5-3	772689	772689	772689	772689	772689	772689	THROAT BEARING	2	
5-4	711937	711937	711937	711937	711937	711937	SPRING	2	
5-5	771740	771740	771740	771740	771740	771740	VALVE SEAT	2	
5-6	832162	832162	832162	832162	832162	832162	PILOT VALVE ASSY.	2	
5-8	640020	640020	640020	640020	640020	640020	O-RING	2	
5-9	685444	685444	685444	685444	685444	685444	PACKING	2	
5-10	640029	640029	640029	640029	640029	640029	O-RING	2	
5-11	771742	771742	771742	771742	771742	771742	GASKET	2	
5-12	683812	683812	683812	683812	683812	683812	FLAT HEAD BOLD	12	
5-13	802971	802971	802971	802971	802971	802971	VALVE BODY ASSY.	1	
5-13-1	711931	711931	711931	711931	711931	711931	VALVE BODY	1	
5-13-2	580999	580999	580999	580999	580999	580999	CAP A	1	
5-13-3	581000	581000	581000	581000	581000	581000	CAP B	1	
5-13-5	771735	771735	771735	771735	771735	771735	SPRING STOPPER	1	
5-13-6	712976	712976	712976	712976	712976	712976	RESET BUTTON	1	
5-13-8	771738	771738	771738	771738	771738	771738	GASKET	2	
5-13-9	685036	685036	685036	685036	685036	685036	BOLT	8	
5-13-12*	805084	805084	805084	805084	805084	805084	C-SPOOL VALVE ASSY.	1	
5-13-12*1	803675	803675	803675	803675	803675	803675	SLEEVE ASSY.	1	
5-13-13	640005	640005	640005	640005	640005	640005	O-RING	1	
5-13-14	684128	684128	684128	684128	684128	684128	CUSHION	4	
5-14	771712	771712	771712	771712	771712	771712	GASKET	1	
5-15	684240	684240	684240	684240	684240	684240	BOLT	6	
5-18	684987	684987	684987	684987	684987	684987	PLAIN WASHER	12	
7	711900	711900	711900	711900	711900	711900	CENTER ROD	1	
8	711904	711904	711904	711904	711904	711904	CENTER DISK	2	
9	713370	713370	713370	713370	713370	713370	CENTER DISK	2	
10	771855	771702	771856	771800	771703	771976	DIAPHRAGM	2	
11	771957	771995	771949	771987	771794	772004	VALVE SEAT	2	
11-HP	711909-HP	711909-HP	711909-HP	711909-HP	711909-HP	711909-HP	VALVE SEAT-HP	2	
12	770627	770630	770633	770636	770630	770633	BALL	2	
14	686974	686974	686974	686974	686974	686974	BALL VALVE	1	
15	682523	682523	682523	682523	682523	682523	ELBOW	1	
19	711928	711928	711928	711928	711928	711928	PUMP BASE	2	
20	771402	771402	771402	771402	771402	771402	CUSHION	4	
21	683408	683408	683408	706128	683408	683408	NUT	2	
22	682740	682740	682740	682740	682740	682740	CONED DISK SPRING	2	
23	686160	686160	686160	686160	686160	686160	BOLT	16	
23a	631917	631917	631917	631917	631917	631917	WAVE SPRING WASHER	16	

Air Operated Double Diaphragm Pump

	NDP-50BFC-HP	NDP-50BFN-HP	NDP-50BFE-HP	NDP-50BFV-HP	NDP-50BFH-HP	NDP-50BFS-HP			
REF No.	PARTS No.	PARTS No.	PARTS No.	PARTS No.	PARTS No.	PARTS No.	DESCRIPTION	QTY.	REORDER
	852841-HP	852837-HP	852842-HP	852840-HP	852838-HP	852843-HP	Hi-Pressure Pumps		
24	631014	631014	631014	631014	631014	631014	PLAIN WASHER	4	
25	631917	631917	631917	631917	631917	631917	WAVE SPRING WASHER	4	
26	611202	611202	611202	611202	611202	611202	BOLT	12	
27	631015	631015	631015	631015	631015	631015	PLAIN WASHER	12	
28	631918	631918	631918	631918	631918	631918	WAVE SPRING WASHER	12	
29	627014	627014	627014	627014	627014	627014	NUT	12	
33	611175	611175	611175	611175	611175	611175	BOLT	4	
34	627013	627013	627013	627013	627013	627013	NUT	4	
35	611149	611149	611149	611149	611149	611149	BOLT	4	
36	682276	682276	682276	682276	682276	682276	NUT W/FLANGE	4	
40	640069	640069	684122	642069	640069	684122	O-RING	4	
51	770582	770582	770582	770582	770582	770582	CUSHION	2	
KIT	K45-AM	K45-AM	K45-AM	K45-AM	K45-AM	K45-AM	AIR MOTOR REBUILD KIT		

Not Shown: Hose Assembly with Fittings

General Tools:

- Socket wrench - 13mm, 17mm, 19mm, 24mm
- Hexagonal box wrench - 5mm, 6mm
- Small crowbars—2 (C/N/EV)
- Open-end wrench - 19mm, 24mm
- Plastic hammer

Special Tools:

- Sleeve remover (713180) used for removing the sleeve (sold separately)

Miscellaneous:

- Assembly Oil - Turbine oil none additional class 1 (equivalent to ISO VGA32 grade)
- Nuts - M16 x 1.5
- Thread Locker
- Urea grease grade (NLGI) No. 2

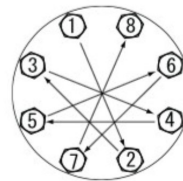

Tightening torque for center rod and out chambers.

Center Rod 43 ft-lbf {60 N-m}
Out Chambers 29 ft-lbf {40 N-m}

Tightening torque for manifold retainer bolts.
BF_ 18 ft-lbf {25 N-m}

Customer Notes	
Model #:	_____
Description:	_____
Serial #:	_____
Date Installed:	_____
Department Location:	_____
Tag/Project:	_____