

EXPLODED VIEW & PARTS LISTING



Air Operated Double Diaphragm Pump

Model: NDP-50BSU

Model #: 852645-U (NPT)

Model #: 852234-U (Flange)

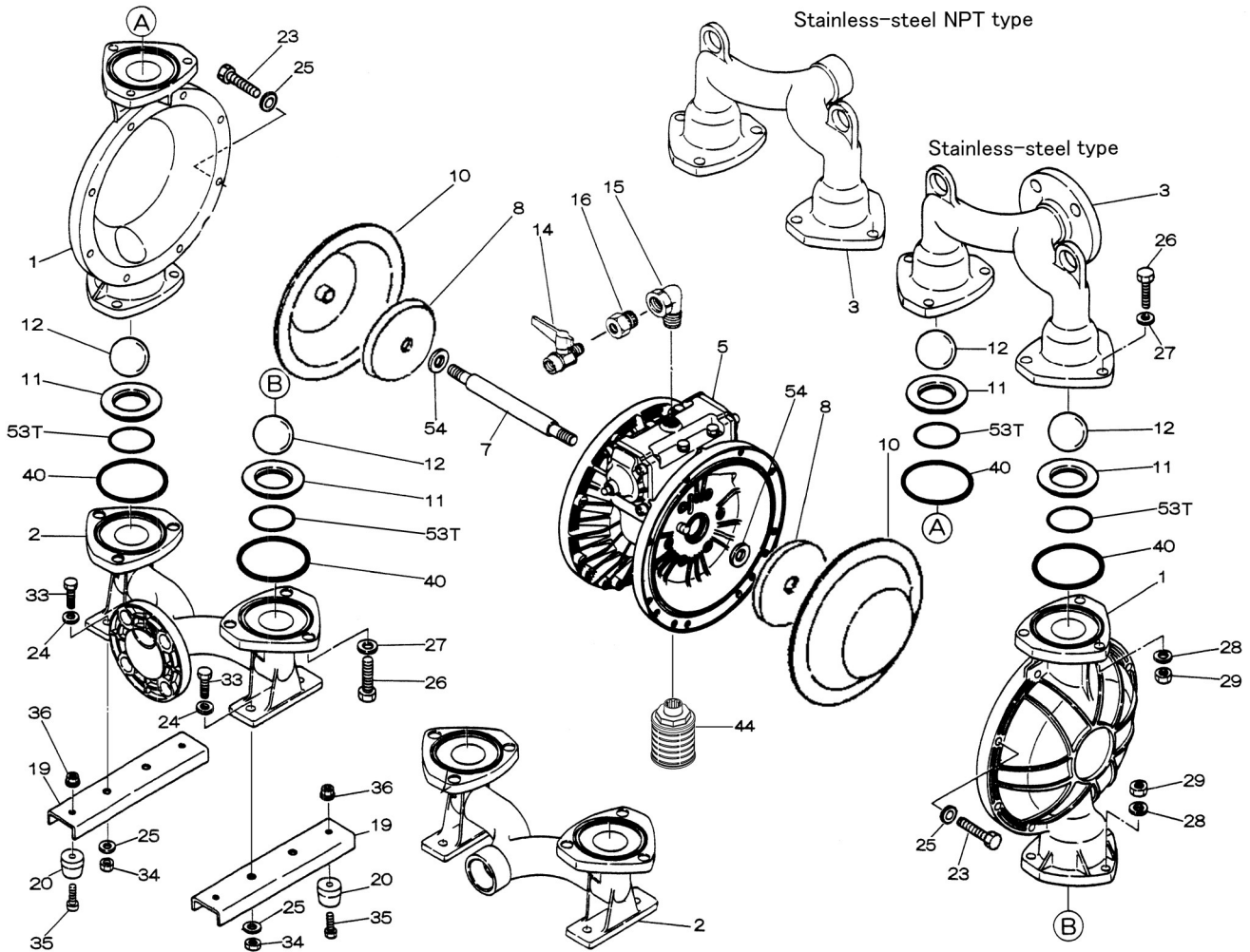
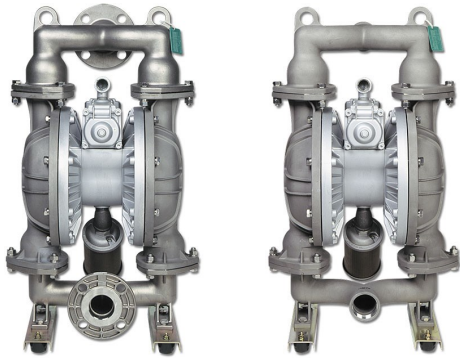

■Body Assembly

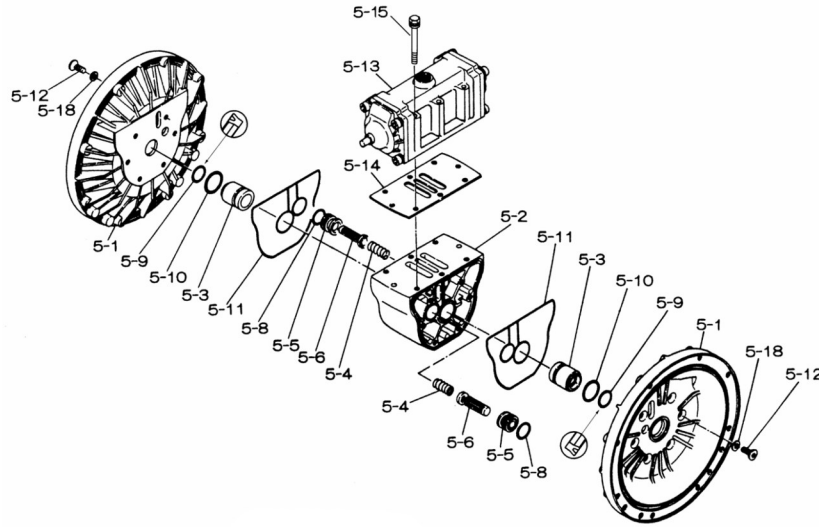

■Valve Body Assembly

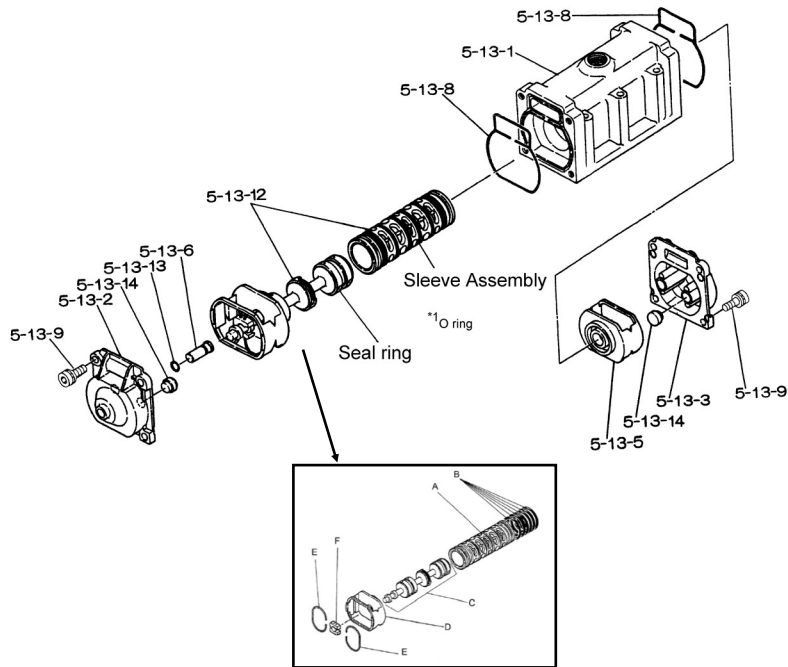

Air Operated Double Diaphragm Pump

REF. No.	PART No.	DESCRIPTION	QTY.	REORDER
NPT	852645-U	** NPT PUMP **		
FLG	852234-U	** FLANGE PUMP **		
1	712932	OUT CHAMBER	2	
2	712559	IN MANIFOLD (NPT)	1	
2	712557	IN MANIFOLD (FLG)	1	
3	712558	OUT MANIFOLD (NPT)	1	
3	712556	OUT MANIFOLD (FLG)	1	
5	803112	CENTER BODY ASSY.	1	
5- 1	711934	AIR CHAMBER	2	
5- 2	711936	BODY	1	
5- 3	772689	THROAT BEARING	2	
5- 4	711937	PILOT VALVE SPRING	2	
5- 5	771740	PILOT VALVE SEAT	2	
5- 6	832162	PILOT VALVE ASSY.	2	
5- 8	640020	O-RING	2	
5- 9	685444	V-PACKING	2	
5-10	640029	O-RING	2	
5-11	771742	GASKET	2	
5-12	683812	FLAT SOCKET	12	
5-13	802971	VALVE BODY ASSY.	1	
5-13-1	711931	VALVE BODY	1	
5-13-2	580999	CAP A	1	
5-13-3	581000	CAP B	1	
5-13-5	771735	SPRING RETAINER	1	
5-13-6	712976	RESET BUTTON	1	
5-13-8	771738	GASKET	2	
5-13-9	685036	SOCKET BOLT	8	
5-13-12	805084	C-SPOOL ASSY	1	
A	803675	SLEEVE ASSY	1	
B	640036	O-RING	6	
C	805085	SPOOL ASSY	1	
D	771735	SPRING RETAINER	1	
E	711932	C-SPRING	2	
F	771734	BLOCK	1	
5-13-13	640005	O-RING	1	
5-13-14	684128	CUSHION	4	
5-14	771712	GASKET	1	
5-15	684240	BOLT W/WASHERS	6	
5-18	684987	WASHER	12	
7	717130	CENTER ROD	1	
8	717133	CENTER DISK	2	
10	833220	DIAPHRAGM	2	
11	711909	VALVE SEAT	4	
12	770693	BALL	4	
14	686974	BALL VALVE	1	
15	682523	ELBOW	1	
19	711928	BASE	2	
20	771402	FOOT RUBBER	4	
23	621180	BOLT	16	

REF. No.	PART No.	DESCRIPTION	QTY.	REORDER
NPT	852645-U	** NPT PUMP **		
FLG	852234-U	** FLANGE PUMP **		
24	631174	FLAT WASHER	4	
25	631937	WAVE WASHER	20	
26	621202	BOLT	12	
27	631175	FLAT WASHER	12	
28	631938	WAVE WASHER	12	
29	628014	NUT	12	
33	621175	BOLT	4	
34	628013	NUT	4	
35	611149	BOLT	4	
36	682276	NUT W/FLANGE	4	
40	643069	O-RING	4	
44	804764	SILENCER ASSY.	1	
53T	643139	O-RING	4	
54	773435	CUSHION	2	
KIT	K50-MU	LIQUID SIDE KIT		
KIT	K45-AM	AIR MOTOR KIT		

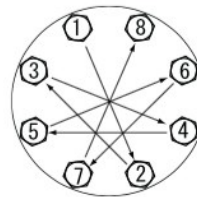

**Tightening torque out chambers.**

Out Chambers 29 ft-lbf {40 N-m}  
 Center Rod 43 ft-lbf {60 N-m}

**Tightening torque for manifold retainer bolts.**

BSU 18 ft-lbf {25 N-m}

**General Tools:**

- Socket wrenches - 13mm, 17mm, 19mm, 24mm
- Hexagonal box wrench - 5mm, 6mm
- Open-end wrenches - 19mm, 24mm
- Plastic hammer

**Special Tools (sold separately):**

- Sleeve remover (713180).

**Miscellaneous:**

- Assembly Oil - turbine oil none additional class 1 (equivalent to ISO VG32 grade)
- Nuts - M16 x 1.5
- Thread locker
- Urea grease grade (NLGI) No. 2

**Customer Notes**

Model #: \_\_\_\_\_  
 Description: \_\_\_\_\_  
 Serial #: \_\_\_\_\_  
 Date Installed: \_\_\_\_\_  
 Department Location: \_\_\_\_\_  
 Tag/Project: \_\_\_\_\_