

OPERATOR'S MANUAL

NM2304A-X-X

SPECIFICATIONS, SERVICE KITS, GENERAL INFORMATION, TROUBLESHOOTING
 INCLUDE MANUALS: 67151-X Lower Pump End (pn 97999-763), 6691X Air Motor (pn 97999-748) & S-632 General Information Manual (pn 97999-624)

RELEASED: 1-2-98
 REVISED: 6-1-10
 (REV. G)

3" AIR MOTOR
4:1 RATIO
3" STROKE

NM2304A-X1-X11
TWO BALL PUMP SERIES
 CARBON STEEL



READ THIS MANUAL CAREFULLY BEFORE INSTALLING, OPERATING OR SERVICING THIS EQUIPMENT.

It is the responsibility of the employer to place this information in the hands of the operator. Keep for future reference.

SERVICE KITS

- Use only genuine ARO® replacement parts to assure compatible pressure rating and longest service life.
- **637316** for repair of air motor section.
- **637176** for repair of 67151-X-311 and -X-511 lower pump section.
- **637228** for repair of 67151-X-C11 lower pump section.

SPECIFICATIONS

Model Series (refer to option chart)	NM2304A-X1-X11
Type	Air Operated, Two Ball
Ratio	4:1
Air Motor	66913
Motor Repair Kit	637316
Motor Diameter	3" (7.62 cm)
Stroke (Double Acting)	3" (7.62 cm)
Air Inlet (female)	1/4 - 18 N.P.T.F. - 1
Lower Pump End Series	
NM2304A-11-C11	67151-1-C11
NM2304A-11-311	67151-1-311
NM2304A-11-511	67151-1-511
NM2304A-41-C11	67151-4-C11
NM2304A-41-311	67151-4-311
NM2304A-41-511	67151-4-511
NM2304A-81-311	67151-8-311
NM2304A-91-311	67151-9-311
NM2304A-A1-C11	67151-A-C11
NM2304A-A1-311	67151-A-311
NM2304A-A1-511	67151-A-511
NM2304A-B1-311	67151-B-311
Material Inlet	
NM2304A-11-X11, -81-, -B1- (female)	1-1/2 - 11-1/2 N.P.T.F. - 1
NM2304A-41-X11, -91-X11, -A1-X11	Immersed Inlet
Material Outlet (female)	3/4 - 14 N.P.T.F. - 1

PERFORMANCE

Air Inlet Pressure Range	0 - 150 p.s.i. (0 - 10.3 bar)
Fluid Pressure Range	0 - 600 p.s.i. (0 - 41.4 bar)
Maximum Rec'd Cycles / Minute	125
Displacement In³ Per Cycle	8.2
Volume / Cycle	4.54 oz. (134.3 ml)
Cycles Per Gallon	28.2
Flow @ 60 Cycles / Minute	2.1 g.p.m. (8.06 l.p.m.)
Noise Level @ 100 p.s.i.	85 db(A) *
Accessories Available	61113 Wall Mount Bracket 66073-1 Air Line Connection Kit

* The pump sound pressure level has been updated to an Equivalent Continuous Sound Level (L_{Aeq}) to meet the intent of ANSI S1. 13-1971, CAGI-PNEUROP S5.1 using four microphone locations.

PUMP DATA

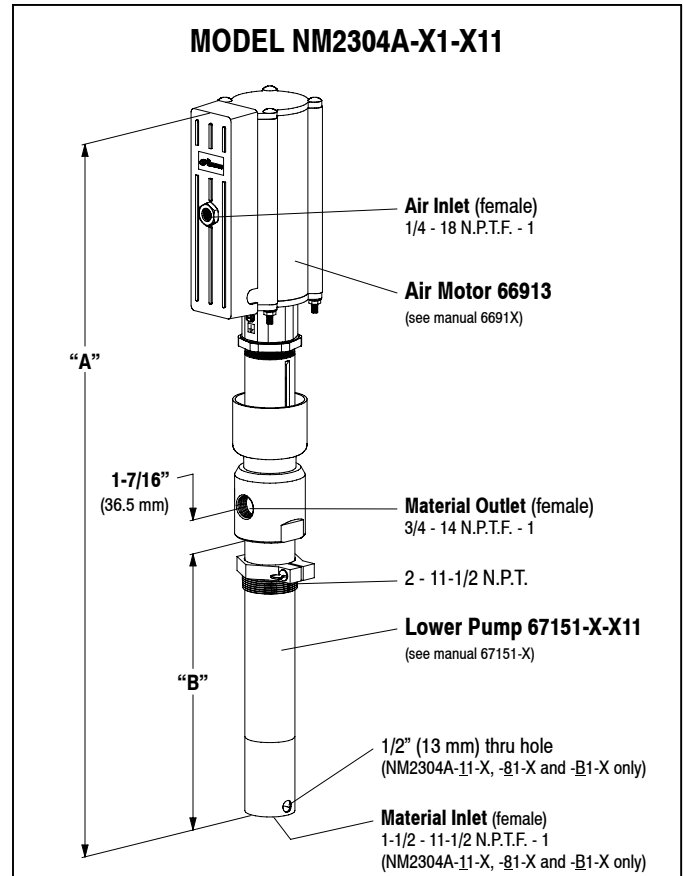

Figure 1

NOTE: Dimensions are shown in inches and (mm), supplied for reference only and are typically rounded up to the nearest 1/16 inch.

Model Number	"A" (mm)	"B" (mm)	Weight (kg)
NM2304A-11-X11	30-11/32" (770.3)	11-23/32" (297.7)	32 lbs (14.5)
NM2304A-41-X11	55-23/32" (1414.9)	37-3/32" (942.2)	46 lbs (20.9)
NM2304A-81-X11	30-11/32" (770.3)	11-23/32" (297.7)	31.4 lbs (14.3)
NM2304A-91-X11	55-23/32" (1414.9)	37-3/32" (942.2)	45.4 lbs (20.6)
NM2304A-A1-X11	29-21/32" (752.9)	11-1/32" (280.2)	31.0 lbs (14.1)
NM2304A-B1-X11	30-11/32" (770.3)	11-23/32" (297.7)	32 lbs (14.5)

IMPORTANT

This is one of the four documents which support the pump. Replacement copies of these forms are available upon request.

- NM2304A-X-X Model Operator's Manual (pn 97999-749)
- S-632 General Information - Industrial Piston Pumps (pn 97999-624)
- 67151-X Lower Pump End Operator's Manual (pn 97999-763)
- 6691X Air Motor Operator's Manual (pn 97999-748)

PUMP OPTION DESCRIPTION CHART

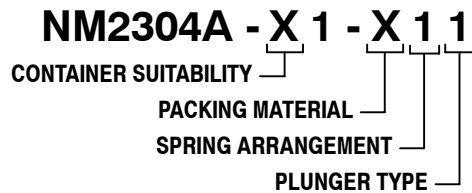

CONTAINER SUITABILITY

- 1 - Universal (Stub)
- 4 - 55 Gallon
- 8 - Universal (Stub) (without bung)
- 9 - 55 Gallon (without bung)
- A - Stub Follower Plate
- B - Universal (Stub) with alternate bung

PACKING MATERIAL

- C - UHMW-PE (upper and lower)
- 3 - Glass filled PTFE (upper)
Virgin PTFE (lower)
- 5 - Glass filled PTFE / Leather staggered (upper)
Virgin PTFE (lower)

SPRING ARRANGEMENT

- 1 - Coil

PLUNGER TYPE

- 1 - Standard (Carbon Steel)

GENERAL DESCRIPTION

The two-ball design provides for easy priming of the lower foot valve. The double acting feature is standard in all ARO industrial pumps. Material is delivered to the pump discharge outlet on both the up and down stroke.

The motor is connected to the lower pump end with a spacer tube and solvent cup. This allows for lubrication of the upper packing gland and to prevent air motor contamination because of normal wear and eventual leakage through the material packing gland.

⚠ WARNING HAZARDOUS PRESSURE. Do not exceed maximum operating pressure of 600 p.s.i. (41.4 bar) at 150 p.s.i. (10.3 bar) inlet air pressure.

PUMP RATIO X	MAXIMUM PUMP
INLET PRESSURE TO PUMP MOTOR	FLUID PRESSURE
=	
Pump ratio is an expression of the relationship between the pump motor area and the lower pump end area. EXAMPLE: When 150 p.s.i. (10.3 bar) inlet pressure is supplied to the motor of a 4:1 ratio pump it will develop a maximum of 600 p.s.i. (41.4 bar) fluid pressure (at no flow) - as the fluid control is opened, the flow rate will increase as the motor cycle rate increases to keep up with the demand.	

⚠ WARNING Refer to general information sheet for additional safety precautions and important information.

NOTICE: Thermal expansion can occur when the fluid in the material lines is exposed to elevated temperatures. Example: Material lines located in a non-insulated roof area can warm due to sunlight. Install a pressure relief valve in the pumping system.

Replacement warning label (pn 94520) is available upon request.

TROUBLE SHOOTING

Pump problems can occur in either the air motor section or the lower pump end section. Use these basic guidelines to help determine which section is affected. Be sure to eliminate any possible non-pump problems before suspecting pump malfunction.

Pump will not cycle.

- No pressure to the motor. See motor manual.
- Restricted return lines. Clean obstruction.
- Damaged motor. Service motor.

No material at the outlet (pump continually cycles).

- Check the material supply, disconnect or shut off the air supply and replenish the material, reconnect.

Material on one stroke only (fast downstroke).

- The lower check may not be seating in the foot valve (see lower pump disassembly). Remove the check from the foot valve, clean and inspect the valve seat area. If check or foot valve are damaged, replace.

Material on one stroke only (fast upstroke).

- The middle packings may be worn (see lower pump disassembly).

Replace the seals as necessary.

Material leakage out of the solvent cup or material appears on the pump plunger rod.

- Tighten the solvent cup until leakage discontinues. If this procedure does not aid in stopping the leakage problem, the upper packings may be worn (see lower pump disassembly). Replace the seals as necessary.

PUMP CONNECTION - UPPER / LOWER

NOTE: All threads are right hand.

1. Loosen (90571) lock nut and unscrew entire pump from the air motor. This will expose (94448) adapter (see figure 2).
2. Remove (Y145-2) retaining ring and (90572) connector pin to remove pump assembly from the air motor.
3. Remove (Y15-21) cotter pin and (94048) clevis pin to remove (94448) adapter.

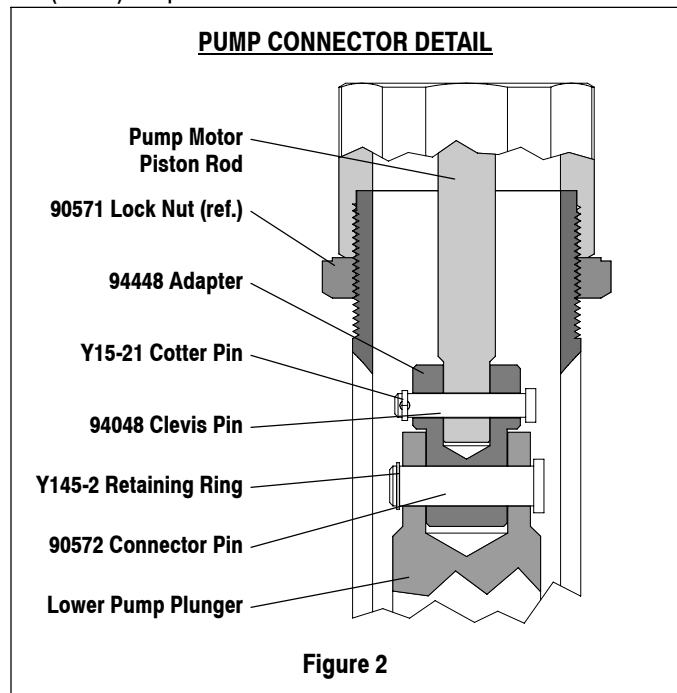

REASSEMBLY

1. Assemble (94448) adapter to air motor rod, aligning through holes.
2. Assemble (94048) clevis pin through hole, securing adapter.
3. Assemble (Y15-21) cotter pin through clevis pin.
4. Assemble (94448) adapter into (90584) plunger, aligning through holes.
5. Assemble (90572) connector pin through hole, securing with (Y145-2) retaining ring.
6. Screw the lower pump assembly to the air motor.
7. Screw (90571) lock nut against air motor base and tighten to 50 - 60 ft lbs (67.8 - 81.3 Nm).