

BALDOR® • ***RELIANCE***

Product Information Packet

CEM7170T-I-5

10HP,1765RPM,3PH,60HZ,215TC,0750M,XPFC,F

Part Detail							
Revision:	D	Status:	PRD/A	Change #:		Proprietary:	No
Type:	AC	Prod. Type:	0750M	Elec. Spec:	07WGY787	CD Diagram:	CD0006
Enclosure:	XPFC	Mfg Plant:		Mech. Spec:	07J232	Layout:	07LYJ232
Frame:	215TC	Mounting:	F1	Poles:	04	Created Date:	11-25-2013
Base:	RG	Rotation:	R	Insulation:	F	Eff. Date:	08-20-2015
Leads:	3#14					Replaced By:	
Literature:		Elec. Diagram:					

Nameplate NP0977XPSLEV											
NO.							CC	010A			
SER.							TEMP CODE	T3C			
SPEC.	07J232Y787G2										
CAT.NO.	CEM7170T-I-5										
HP	10										
VOLTS	575										
AMPS	10.1										
RPM	1765						MOTOR WEIGHT	252			
HERTZ	60	PH	3	CL	F	DE BRG	6307				
SER.F.	1.15	DES	A	CODE	J	ODE BRG	6206				
FRAME	215TC		GREASE	POLYREX EM							
RATING	40C AMB-CONT 55C AMB AT 1.0 SF										
USABLE AT 208V							NEMA-NOM-EFF	92.4		PF	80
	NEMA MG-1 PT 5,IP55										

Parts List		
Part Number	Description	Quantity
SA272923	SA 07J232Y787G2	1.000 EA
RA259528	RA 07J232Y787G2	1.000 EA
37FN3002B01	EXFN, PLASTIC, 7.50 OD, 1.155 ID	1.000 EA
HA3210E08	.250X 7/8 PIN 312-57	1.000 EA
HW3201A05	3/8-16 EYEBOLT	1.000 EA
07CB1000A01	CONDUIT BOX MACH	1.000 EA
10XN3118A16	5/16-18X1 HEX HD CAP	4.000 EA
HW1001A31	LOCKWASHER 5/16, ZINC PLT.591 OD, .319 I	4.000 EA
11XW1032G06	10-32 X .38, TAPTITE II, HEX WSHR SLTD U	1.000 EA
WD1000B17	T&B CX35TN TERMINAL	1.000 EA
07EP1707A17	FREP XP GR C W/DRAINS, GRSRS	1.000 EA
HW4500A19	1/4-28X1/4 SLOTTED PLUG F/S	2.000 EA
HW4506A02	BREATHER/DRAIN-EXP PROOF-.125-27 NPTF AI	1.000 EA
HW3022E05	.125 DIA X .500 ROLLED SPRING PIN	1.000 EA
10XN3816K28	3/8-16 X 1.75 HEX HD CAP SCREW, GRADE 5	4.000 EA
HW1001A38	LOCKWASHER 3/8, ZINC PLT .688 OD, .382 I	4.000 EA
HW5100A06	W2420-025 WVY WSHR (WB)	1.000 EA
07EP1708A12	PUEP 213-5TC 307M "DRILL RIG DUTY" SLING	1.000 EA
HW4500A19	1/4-28X1/4 SLOTTED PLUG F/S	2.000 EA
HW4506A02	BREATHER/DRAIN-EXP PROOF-.125-27 NPTF AI	1.000 EA
HW3022E05	.125 DIA X .500 ROLLED SPRING PIN	1.000 EA
10XN3816K28	3/8-16 X 1.75 HEX HD CAP SCREW, GRADE 5	4.000 EA
HW1001A38	LOCKWASHER 3/8, ZINC PLT .688 OD, .382 I	4.000 EA
10XN2520A32	1/4 X 2 HEX HEAD CAP SCR, GRADE 2	4.000 EA

Parts List (continued)		
Part Number	Description	Quantity
HW1001A25	LOCKWASHER 1/4, ZINC PLT .493 OD, .255 I	4.000 EA
07FH1003A01	STANDARD 307 EXPLOSION PROOF FAN HOUSING	1.000 EA
10XN2520A12	O1/4-20X 3/4 HEX HEAD CAP	4.000 EA
07CB1502A01	CONDUIT BOX LID MACH (DUCTILE IRON)	1.000 EA
84XN2520J16	1/4-20 X 1 SOC HD CAP SCREW	4.000 EA
HW1001A25	LOCKWASHER 1/4, ZINC PLT .493 OD, .255 I	4.000 EA
HA2065A02	SLINGER, ALUM MODLE 36 & 37 DRILL RIG MT	1.000 EA
80XN1032A07	SET SCREW, HEX XOCK, ZN	1.000 EA
HW2501F21	KEY, 5/16 SQ X 2.375	1.000 EA
HA7000A02	KEY RETAINER RING, 1 1/8 DIA, 1 3/8 DIA	1.000 EA
LB1081F	ALUM XP CAUTION LABEL (FS PLANT ONLY-	1.000 EA
LB1115N	LABEL,LIFTING DEVICE (ON ROLLS)	1.000 EA
85XU0407S04	4X1/4 U DRIVE PIN STAINLESS	6.000 EA
MJ1000A02	GREASE, POLYREX EM EXXON (USe 4824-15A)	0.050 LB
51XB1214A20	12-14X1.25 HXWSSLD SERTYB	1.000 EA
MG1025G29	WILKOFASST, 789.229, DARK CHARCOAL GRAY	0.036 GA
LB1119N	WARNING LABEL	1.000 EA
LC0006	CONNECTION LABEL	1.000 EA
MN416A01	TAG-INSTAL-MAINT no wire (1200/bx) 11/14	1.000 EA
NP0977XPSLEV	SS XP UL CSA-EEV CC CL-I GP-C&D	1.000 EA
07PA1011	PKG GRP, 07 CAST IRON PK1181	1.000 EA

AC Induction Motor Performance Data

Record # 32082 - Typical performance - not guaranteed values

Winding: 07WGY787-R001	Type: 0750M	Enclosure: XPFC
-------------------------------	--------------------	------------------------

Nameplate Data				575 V, 60 Hz: Single Voltage Motor	
Rated Output (HP)	10			Full Load Torque	29.7 LB-FT
Volts	575			Start Configuration	direct on line
Full Load Amps	10.1			Breakdown Torque	95.8 LB-FT
R.P.M.	1765			Pull-up Torque	57.3 LB-FT
Hz	60	Phase	3	Locked-rotor Torque	63.5 LB-FT
NEMA Design Code	A	KVA Code	J	Starting Current	78 A
Service Factor (S.F.)	1.15			No-load Current	4.63 A
NEMA Nom. Eff.	92.4	Power Factor	80	Line-line Res. @ 25°C	1.35 Ω
Rating - Duty	40C AMB-CONT			Temp. Rise @ Rated Load	59°C
S.F. Amps				Temp. Rise @ S.F. Load	72°C
				Locked-rotor Power Factor	35
				Rotor inertia	1.23 LB-FT ²

Load Characteristics 575 V, 60 Hz, 10 HP

% of Rated Load	25	50	75	100	125	150	S.F.
Power Factor	40	62	75	80	83	85	82
Efficiency	90.5	93.6	92.9	92.4	91.6	90.4	91.9
Speed	1790	1782	1772	1764	1754	1744	1758
Line amperes	5.16	6.41	8.1	10.1	12.3	14.7	11.4

Performance Graph at 575V, 60Hz, 10.0HP Typical performance - Not guaranteed values

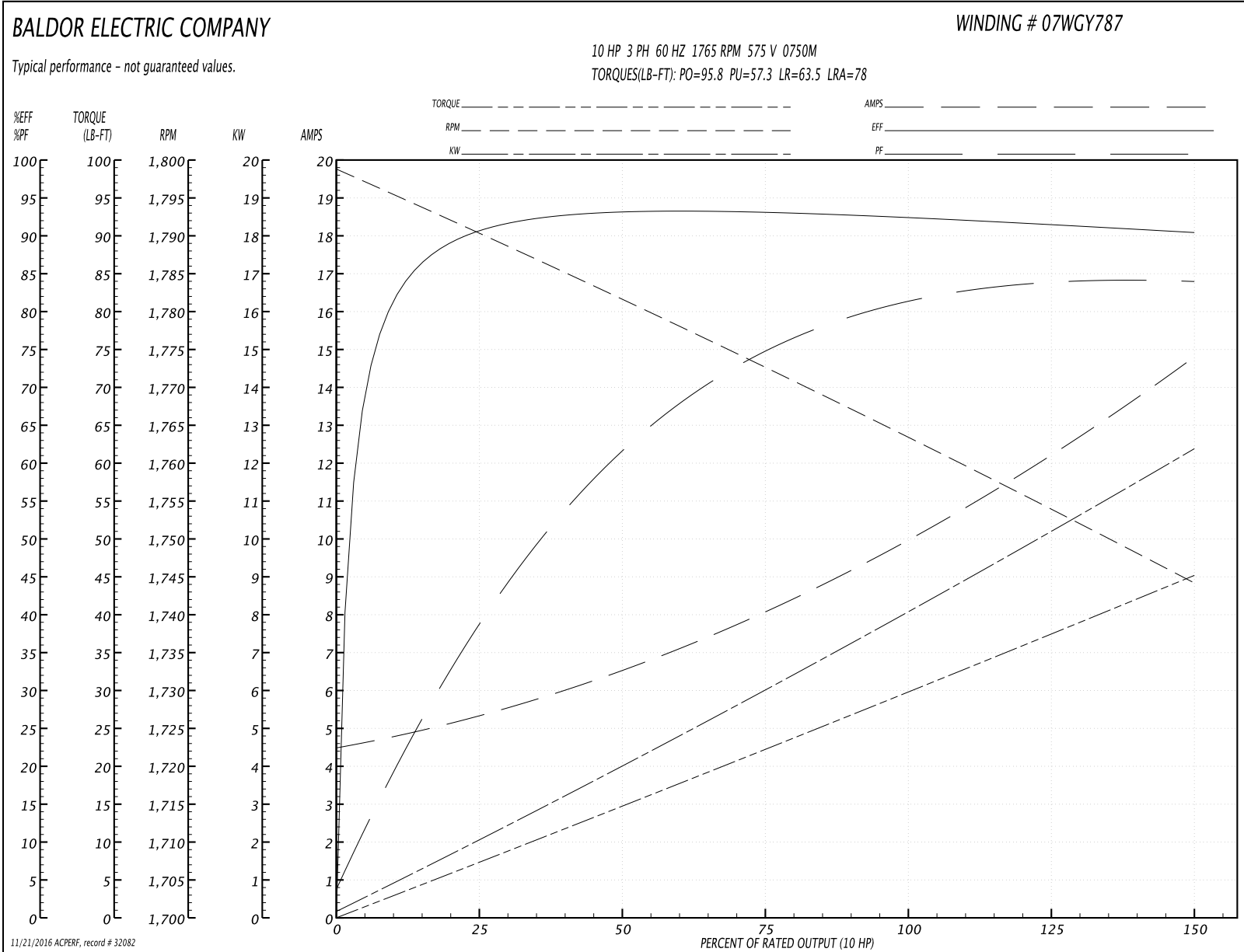

07LYJ232

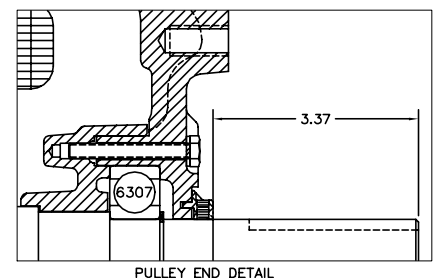
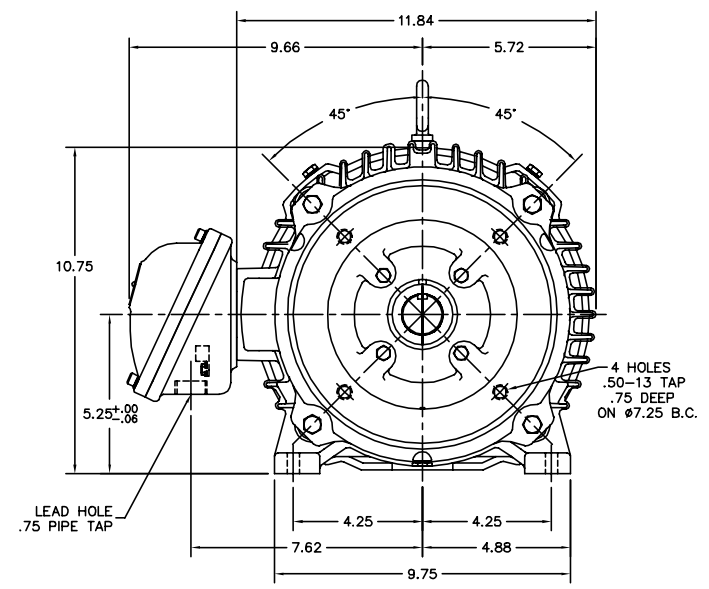
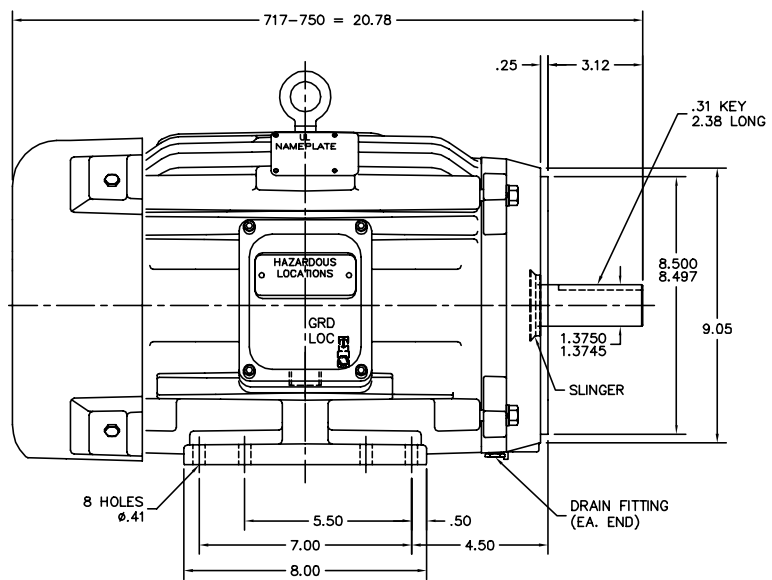

CUSTOMER IS RESPONSIBLE FOR DETERMINING THAT MOTOR PERFORMANCE IS SUITABLE IN THE APPLICATION.

REV. DESC: 07SH5145 WAS 07SH5088	
REV. LTR: B BY: OD REVISED: 11:58:36 05/22/2002 TDR: 271902	
FILE: AAA00076168	REF: 07LYJ232
MTL: -	

BALDOR ELECTRIC Co.
HORZ 213-5TC XPFC 307M CL-I GP-C&D (DRILL RIG MOTOR)

07LYJ232

CD0006



NOTES:

1. THREE LEAD MOTOR MAY BE EITHER WYE CONNECTED OR DELTA CONNECTED.
2. INTERCHANGE ANY TWO LINE LEADS TO REVERSE ROTATION.
3. OPTIONAL THERMOSTATS ARE PROVIDED WHEN SPECIFIED.
4. ACTUAL NUMBER OF INTERNAL PARALLEL CIRCUITS MAY VARY.
5. LEAD COLORS ARE OPTIONAL. LEADS MUST BE NUMBERED AS SHOWN.

REV. DESC: REVISE TO SHOW OPTIONAL COLORS			
REV. LTR: D	BY: JLP	REVISED: 01/21/99 4:02	TDR: 0171435
9000D		FILE: AAA00005141	MDL: -
		MTL: -	

BALDOR ELECTRIC Co.

3PH, SV, 3 LEADS, WYE OR DELTA CONNECTED

CD0006