

BALDOR® • ***RELIANCE***

Product Information Packet

FDEM4104T

30HP,1760RPM,3PH,60HZ,286T,1056M,TEFC,F1

Part Detail							
Revision:	C	Status:	PRD/A	Change #:		Proprietary:	No
Type:	AC	Prod. Type:	1056M	Elec. Spec:	10WGY538	CD Diagram:	CD0180
Enclosure:	TEFC	Mfg Plant:		Mech. Spec:	10J526	Layout:	10LYJ526
Frame:	286T	Mounting:	F1	Poles:	04	Created Date:	12-13-2013
Base:	RG	Rotation:	R	Insulation:	F	Eff. Date:	12-15-2015
Leads:	9#8					Replaced By:	
Literature:		Elec. Diagram:					

Nameplate NP3126L										
CAT.NO.	FDEM4104T									
SPEC.	10J526Y538G1									
HP	30									
VOLTS	230/460									
AMP	76/38									
RPM	1760									
FRAME	286T				HZ	60			PH	3
SER.F.	1.15		CODE	J	DES	A		CL	F	
NEMA-NOM-EFF	93.6		PF	80						
RATING	40C AMB-CONT									
CC	010A				USABLE AT 208V			78		
DE	6311				ODE	6309				
ENCL	TEFC		SN							

Parts List		
Part Number	Description	Quantity
SA273883	SA 10J526Y538G1	1.000 EA
RA260474	RA 10J526Y538G1	1.000 EA
S/P107-000-004	SUPER-E(284 FR. & UP)-CL PLANT,POLYREX E	1.000 EA
10CB3000SP	STD KO BOX MODEL 310,312,314 MTRS W/2.00	1.000 EA
12GS1000SP	GASKET	1.000 EA
10XN3118K12	5/16-18 X .75 GRADE 5, ZINC PLATED	4.000 EA
HW1001A31	LOCKWASHER 5/16, ZINC PLT.591 OD, .319 I	4.000 EA
WD1000B16	T&B CX70TN TERMINAL	1.000 EA
51XF2520A08	SCREW, HEX SER SLT HD, ZN 1/4-20 X .50 L	1.000 EA
10EP1106A55	FREP MACH W/O GREASERS, W/"O" DRAINS	1.000 EA
10XN3816K32	BOLT, 3/8-16X2 HH YZ(5)	4.000 EA
HW1001A38	LOCKWASHER 3/8, ZINC PLT .688 OD, .382 I	4.000 EA
HW5100A11	W3917-042 WVY WSHR (WB)	1.000 EA
10XN3118K40	5/16-18 X 2.50" HEX HD, GRADE 5	4.000 EA
HW1001A31	LOCKWASHER 5/16, ZINC PLT.591 OD, .319 I	4.000 EA
10EP1105A112	PUEP MACH W/LIP SEAL,"O" DRAIN,W/O GRSR	1.000 EA
10XN3816K28	3/8-16 X 1.75 HEX HD CAP SCREW, GRADE 5	4.000 EA
HW1001A38	LOCKWASHER 3/8, ZINC PLT .688 OD, .382 I	4.000 EA
HW4600A53	SEAL 2.00 X 3.00 X 0.313 SINGLE LIP	1.000 EA
HW4600B40	V-RING SLINGER 2.000 X 2.680 X .28 VITON	1.000 EA
10FH4000	310 FAN HOUSING STAMPED	1.000 EA
51XF2520A08	SCREW, HEX SER SLT HD, ZN 1/4-20 X .50 L	4.000 EA
10CB3500SP	CONDUIT BOX LID, CAST	1.000 EA
10GS1000SP	GASKET, CONDUIT BOX LID	1.000 EA

Parts List (continued)		
Part Number	Description	Quantity
51XW2520A12	.25-20 X .75, TAPTITE II, HEX WSHR SLTD	4.000 EA
HW2501H28	KEY, 1/2 SQ X 3.250	1.000 EA
LB1115N	LABEL,LIFTING DEVICE (ON ROLLS)	1.000 EA
MN416A01	TAG-INSTAL-MAINT no wire (1000/bx) 11/14	1.000 EA
HA4066A01	PUSH IN T-DRAIN FITTING (BLACK)	1.000 EA
MJ1000A02	GREASE, POLYREX EM EXXON (USe 4824-15A)	0.130 LB
HA4066A01	PUSH IN T-DRAIN FITTING (BLACK)	1.000 EA
09FN3001C02	EXTERNAL FAN, PLASTIC	1.000 EA
HW2500A25	WOODRUFF KEY USA #1008 #BLOW CARBON STEE	1.000 EA
51XB1214A20	12-14X1.25 HXWSSLD SERTYB	1.000 EA
MG1025C02	WILKOFASST SG, 787.105, TAN	0.050 GA
85XU0407S04	4X1/4 U DRIVE PIN STAINLESS	2.000 EA
LB1119N	WARNING LABEL	1.000 EA
LC0181	CONNECTION LABEL	1.000 EA
NP3126L	ALUM FARM DUTY SUPER-E UL CSA-EEV PREM	1.000 EA
10PA1000	PACKAGING GROUP COMBINED PRINT PK1023A06	1.000 EA

AC Induction Motor Performance Data

Record # 32189 - Typical performance - not guaranteed values

Winding: 10WGY538-R004	Type: 1056M	Enclosure: TEFC
-------------------------------	--------------------	------------------------

Nameplate Data				460 V, 60 Hz: High Voltage Connection	
Rated Output (HP)	30			Full Load Torque	88.7 LB-FT
Volts	230/460			Start Configuration	direct on line
Full Load Amps	76/38			Breakdown Torque	330 LB-FT
R.P.M.	1760			Pull-up Torque	142 LB-FT
Hz	60	Phase	3	Locked-rotor Torque	178 LB-FT
NEMA Design Code	A	KVA Code	J	Starting Current	270 A
Service Factor (S.F.)	1.15			No-load Current	17.9 A
NEMA Nom. Eff.	93.6	Power Factor	80	Line-line Res. @ 25°C	0.19377 Ω
Rating - Duty	40C AMB-CONT			Temp. Rise @ Rated Load	64°C
S.F. Amps				Temp. Rise @ S.F. Load	76°C
				Locked-rotor Power Factor	30.9
				Rotor inertia	4.47 LB-FT ²

Load Characteristics 460 V, 60 Hz, 30 HP

% of Rated Load	25	50	75	100	125	150	S.F.
Power Factor	41	63	73	80	82	85	81
Efficiency	87.6	92.3	93.5	93.7	93.4	92.9	93.5
Speed	1792.2	1787.6	1782.4	1776.5	1770.3	1762.1	1773
Line amperes	19.8	24.3	30.7	37.6	45.6	55.2	42.4

Performance Graph at 460V, 60Hz, 30.0HP Typical performance - Not guaranteed values

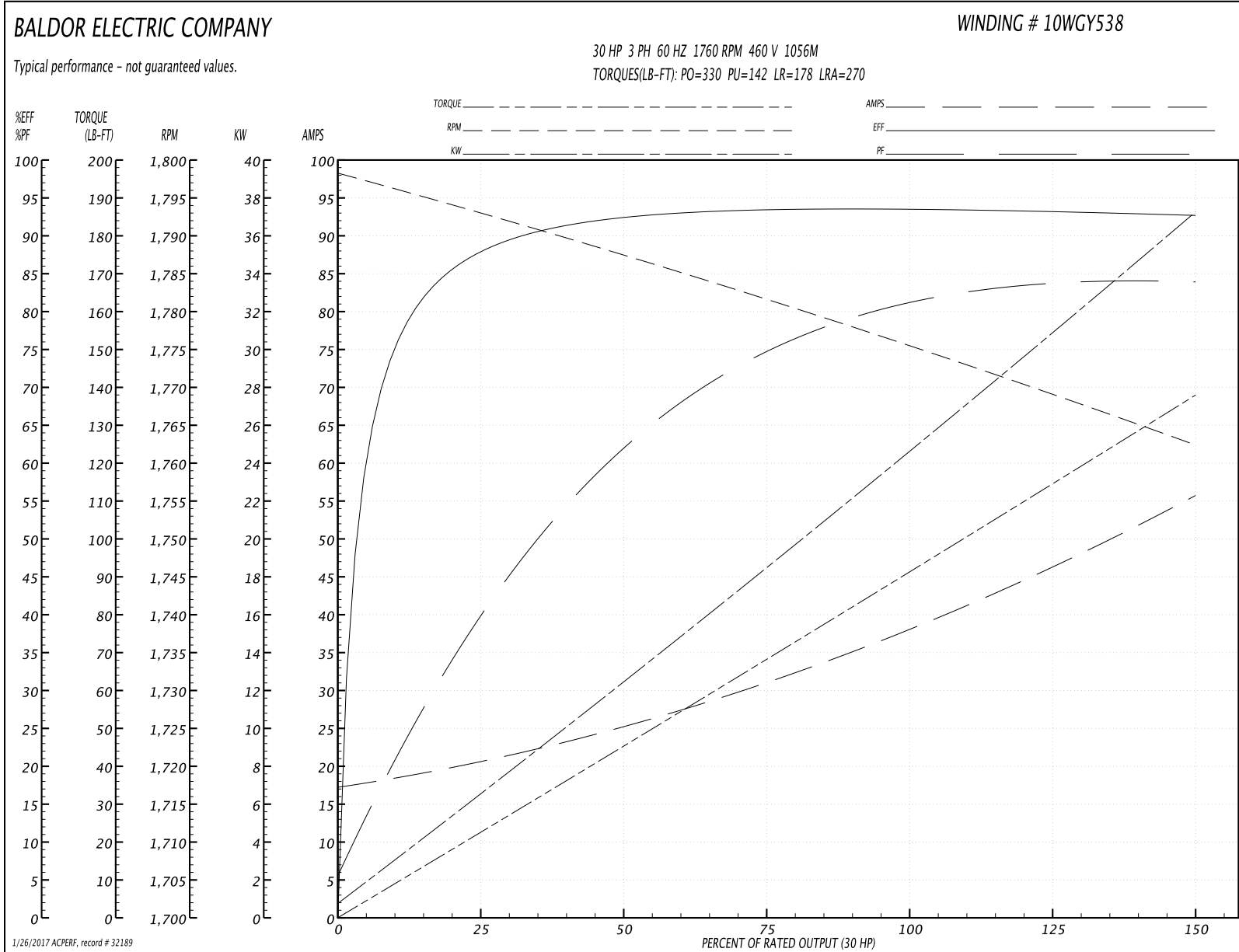

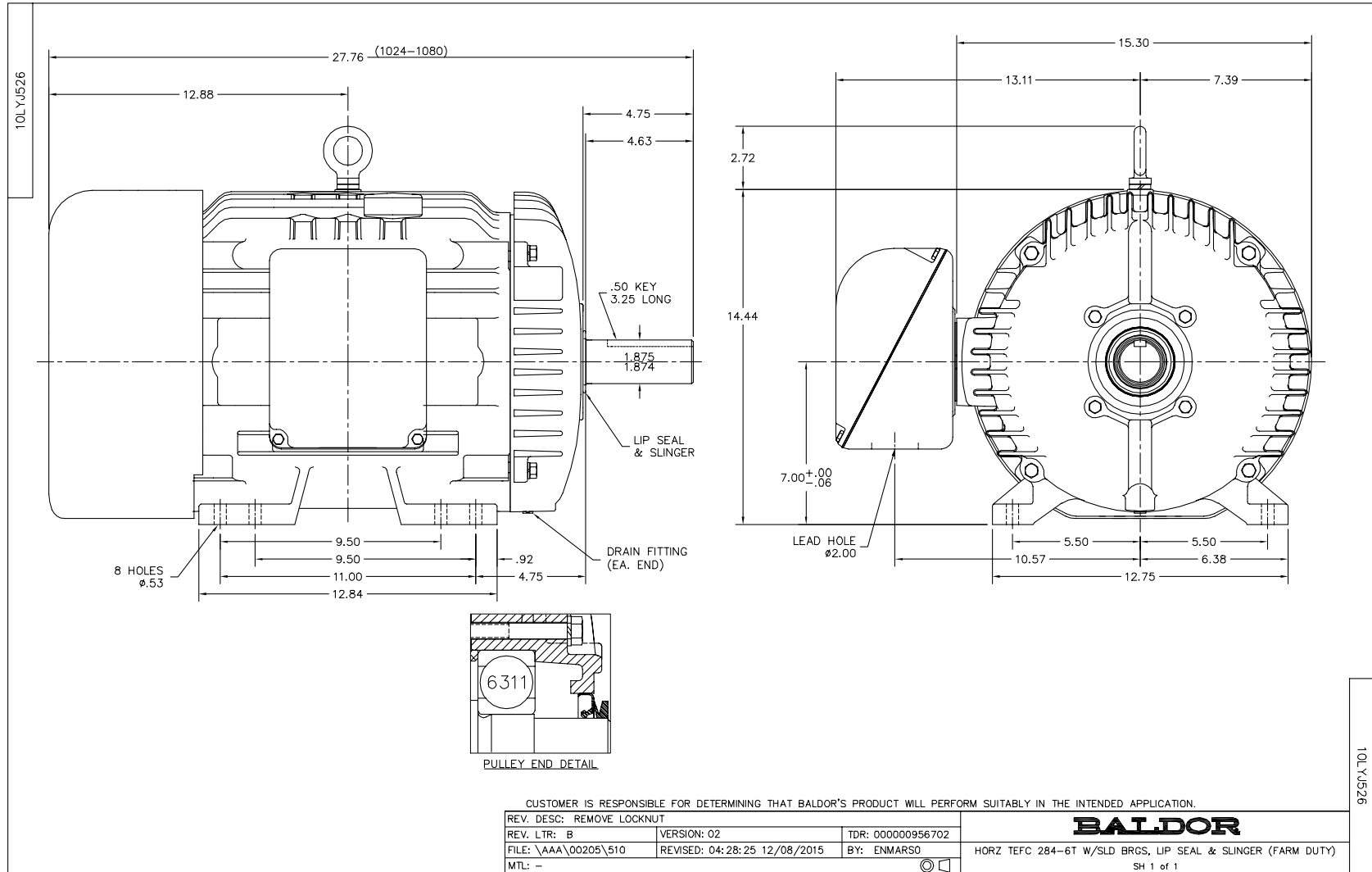

CD0180



LOW VOLTAGE
(2D)



HIGH VOLTAGE
(1D)



NOTES:

1. INTERCHANGE ANY TWO LINE LEADS TO REVERSE ROTATION.
2. OPTIONAL THERMOSTATS ARE PROVIDED WHEN SPECIFIED.
3. ACTUAL NUMBER OF INTERNAL PARALLEL CIRCUITS MAY BE A MULTIPLE OF THOSE SHOWN ABOVE.
4. LEAD COLORS ARE OPTIONAL. LEADS MUST ALWAYS BE NUMBERED AS SHOWN.

REV. DESC: REVISE TO SHOW OPTIONAL COLORS			
REV. LTR: C	BY: JLP	REVISED: 01/21/99 2:28	TDR: 0171435
0810D0		FILE: AAA00005148	MDL: -
		MTL: -	

BALDOR ELECTRIC Co.

3PH, DV, 9 LEADS, DELTA CONNECTION

CD0180