

# BARNES®

## INSTALLATION MANUAL Submersible Single-Stage Grinder Pump



**Series:**  
1 HP, 3450 RPM, 60Hz



**IMPORTANT!**

*Read all instructions in this manual before operating pump.  
As a result of Crane Pumps & Systems, Inc., constant product improvement program,  
product changes may occur. As such Crane Pumps & Systems reserves the right to  
change product without prior written notification.*

**CRANE**

A Crane Co. Company

PUMPS & SYSTEMS

420 Third Street  
Piqua, Ohio 45356  
Phone: (937) 778-8947  
Fax: (937) 773-7157  
www.cranepumps.com

83 West Drive, Bramton  
Ontario, Canada L6T 2J6  
Phone: (905) 457-6223  
Fax: (905) 457-2650



# SAFETY FIRST!

Please Read This Before Installing Or Operating Pump. This information is provided for **SAFETY and to PREVENT EQUIPMENT PROBLEMS**. To help recognize this information, observe the following symbols:



**IMPORTANT!** Warns about hazards that can result in personal injury or indicates factors concerned with assembly, installation, operation, or maintenance which could result in damage to the machine or equipment if ignored.

**CAUTION !** Warns about hazards that can or will cause minor personal injury or property damage if ignored. Used with symbols below.

**WARNING !** Warns about hazards that can or will cause serious personal injury, death, or major property damage if ignored. Used with symbols below.



Hazardous fluids can cause fire or explosions, burns or death could result.



Extremely hot - Severe burns can occur on contact.



Biohazard can cause serious personal injury.



Hazardous fluids can cause hazardous pressure, eruptions or explosions could cause personal injury or property damage.



Rotating machinery Amputation or severe laceration can result.



Hazardous voltage can shock, burn or cause death.

Only qualified personnel should install, operate and repair pump. Any wiring of pumps should be performed by a qualified electrician.



**WARNING !** - To reduce risk of electrical shock, pumps and control panels must be properly grounded in accordance with the National Electric Code (NEC) or the Canadian Electrical Code (CEC) and all applicable state, province, local codes and ordinances.

**WARNING!** - To reduce risk of electrical shock, always disconnect the pump from the power source before handling or servicing. Lock out power and tag.

Prevent large articles of clothing, large amounts of chemicals, other materials or substances such as are uncommon in domestic sewage from entering the system.

During power black-outs, minimize water consumption at the home(s) to prevent sewage from backing up into the house.

Always keep the shut-off valve completely open when system is in operation (unless advised otherwise by the proper authorities). Before removing the pump from the basin, be sure to close the shut-off valve. (This prevents backflow from the pressure sewer.)

Keep the control panel locked or confined to prevent unauthorized access to it.

If the pump is idle for long periods of time, it is advisable to start the pump occasionally by adding water to the basin.



**CAUTION!** Pumps build up heat and pressure during operation-allow time for pumps to cool before handling or servicing.



**WARNING!** - **DO NOT** pump hazardous materials (flammable, caustic, etc.) unless the pump is specifically designed and designated to handle them.

Do not block or restrict discharge hose, as discharge hose may whip under pressure.



**WARNING!** - **DO NOT** wear loose clothing that may become entangled in the impeller or other moving parts.

**WARNING!** - Keep clear of suction and discharge openings. **DO NOT** insert fingers in pump with power connected.

Make sure lifting handles are securely fastened each time before lifting. Do not operate pump without safety devices in place. Always replace safety devices that have been removed during service or repair.

Do not exceed manufacturers recommendation for maximum performance, as this could cause the motor to overheat.

Secure the pump in its operating position so it can not tip over, fall or slide.

Cable should be protected at all times to avoid punctures, cut, bruises and abrasions - inspect frequently.



Never handle connected power cords with wet hands.

To reduce risk of electrical shock, all wiring and junction connections should be made per the NEC or CEC and applicable state or province and local codes. Requirements may vary depending on usage and location.



Submersible Pumps are not approved for use in swimming pools, recreational water installations, decorative fountains or any installation where human contact with the pumped fluid is common.

Do not remove cord and strain relief. Do not connect conduit to pump.

Products Returned Must Be Cleaned, Sanitized, Or Decontaminated As Necessary Prior To Shipment, To Insure That Employees Will Not Be Exposed To Health Hazards In Handling Said Material. All Applicable Laws And Regulations Shall Apply.



Bronze/brass and bronze/brass fitted pumps may contain lead levels higher than considered safe for potable water systems. Lead is known to cause cancer and birth defects or other reproductive harm. Various government agencies have determined that leaded copper alloys should not be used in potable water applications. For non-leaded copper alloy materials of construction, please contact factory.



**IMPORTANT!** - Crane Pumps & Systems, Inc. is not responsible for losses, injury, or death resulting from a failure to observe these safety precautions, misuse or abuse of pumps or equipment.

Other brand and product names are trademarks or registered trademarks of their respective holders.

® Barnes is a registered trademark of Crane Pumps & Systems Inc.

4/07

Alteration Rights Reserved

# USER GUIDE

## USER GUIDE

Congratulations on your purchase of a Barnes Rival grinder pump system. With proper care and by following a few simple guidelines your grinder pump will give you many years of dependable service.

### Use and Care

The Rival grinder pump station is designed to handle routine, domestic sewage. Solid waste materials should be thrown in the trash. While your station is capable of accepting and pumping a wide range of materials, regulatory agencies advise that the following items should not be introduced into any sewer either directly or through a kitchen waste disposal:

- Glass
- Metal
- Diapers
- Socks, rags or cloth
- Plastic objects (e.g., toys, utensils, etc.)
- Sanitary napkins or tampons

In addition you must **NEVER** introduce into any sewer:

- Explosives
- Flammable Material
- Lubricating Oil and/or Grease
- Strong Chemicals
- Gasoline

### General Information

Your home wastewater disposal service is part of a low pressure sewer system. The key element in this system is the Barnes Rival grinder pump station. The basin collects all wastewater from the house. The solids in the sewage are then ground to a small size suitable for pumping in the slurry.

The grinder pump generates sufficient pressure to pump this slurry from your home to the wastewater plant.

### Power Failure

Your grinder pump cannot dispose of wastewater or provide an alarm signal without electrical power. If electrical power service is interrupted, keep water usage to a minimum.

### Warranty

Your grinder pump is furnished with a warranty against defects in material or workmanship. A properly completed

Start-Up/Warranty Registration form must be on file at the Barnes factory in order to activate your warranty. In addition your pump must be installed in accordance with the installation instructions.

If you have a claim under the provisions of the warranty, contact your local Barnes Distributor.

When contacting your representative for service, please include your station serial number, pump model number, and pump serial number.

For future reference, record the following information:

Station Serial No: \_\_\_\_\_

Pump Model No: \_\_\_\_\_

Pump Serial No: \_\_\_\_\_

Local Distributor: \_\_\_\_\_

Distributor Telephone: \_\_\_\_\_

## PUMP SPECIFICATIONS:

<b>DISCHARGE</b> .....	2" NPT
<b>LIQUID TEMPERATURE</b> .....	104°F (40°C) Continuous
<b>VOLUTE</b> .....	Cast Iron ASTM A-48, Class 30
<b>MOTOR HOUSING</b> .....	Cast Iron ASTM A-48, Class 30
<b>SEAL PLATE</b> .....	Cast Iron ASTM A-48, Class 30
<b>IMPELLERS:</b> <i>Design:</i> .....	Semi-open, With Pump Out Vanes On Back Side. Dynamically Balanced, ISO G6.3.
<i>Material:</i> .....	Bronze
<b>CUTTER PLATE</b> .....	Hardened 440C Stainless Steel Rockwell® C-55.
<b>CUTTER</b> .....	Hardened 440C Stainless Steel, Rockwell® C-55.
<b>SHAFT</b> .....	416 Stainless Steel
<b>SQUARE RINGS</b> .....	Buna-N
<b>HARDWARE</b> .....	300 Series Stainless Steel
<b>PAINT</b> .....	Powder Coat
<b>SEAL:</b> <i>Design:</i> .....	Single Mechanical
<i>Material:</i> .....	Rotating Faces - Silicon-Carbide Stationary Faces - Silicon-Carbide Elastomer - Buna-N Hardware -300 Series Stainless

<b>CORD ENTRY</b> .....	20 ft.
<b>CORD</b> <i>Manual</i> .....	CSA/UL Approved, 14/3 Type SJTOW

### UPPER BEARING:

<i>Design</i> .....	Single Row, Ball
<i>Lubrication</i> .....	Oil
<i>Load</i> .....	Radial & Thrust

### LOWER BEARING:

<i>Design</i> .....	Single Row, Ball
<i>Lubrication</i> .....	Oil
<i>Load</i> .....	Radial & Thrust

### MOTOR:

<i>Design</i> .....	NEMA L-Single Phase Torque Curve, Oil-Filled, Squirrel Cage Induction (includes overload protection in the motor),
<i>Insulation</i> .....	Class F

**SINGLE PHASE** .....

**OPTIONAL EQUIPMENT**..... Float

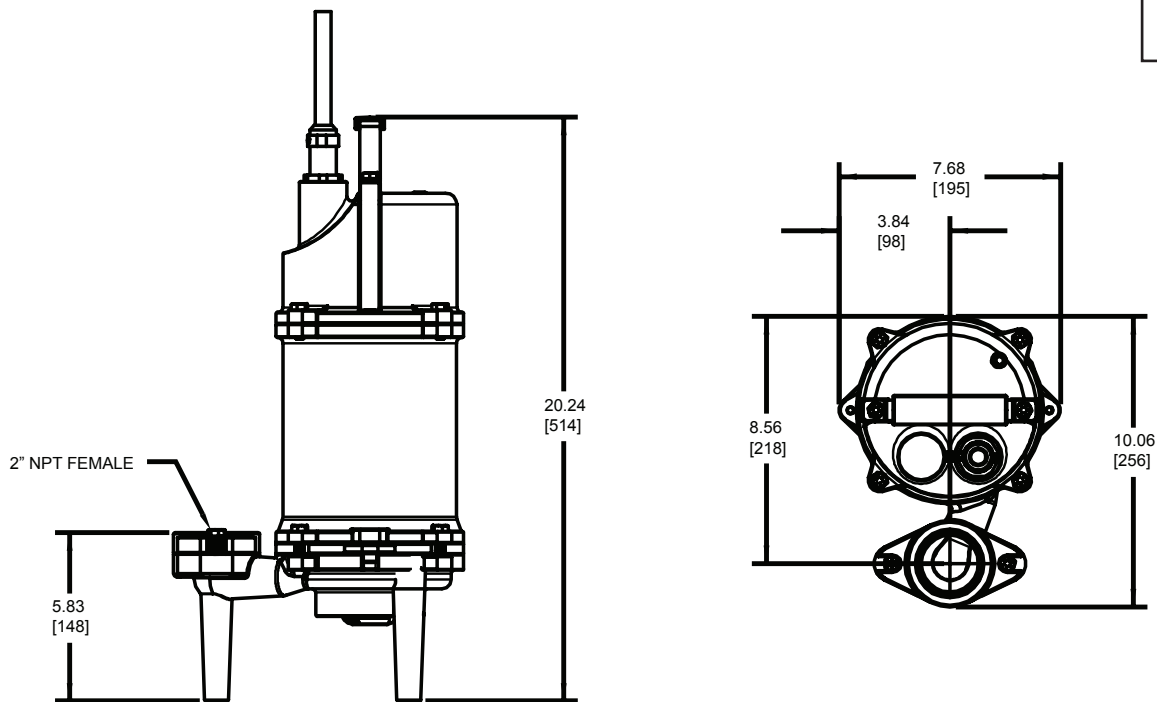

inches  
(mm)

MODEL NO	HP	VOLT	PH	FRE-QUENCY	NEMA START CODE	FULL LOAD AMPS	LOCKED ROTOR AMPS	CORD SIZE	CORD O.D. ± .02 (-.5) in (mm)	WINDING RESISTANCE MAIN -- START	RECOMMENDED BREAKER SIZE
RV101	1	115	1	60	G	12	43	14/3	.33	1.0 -- 3.9	15 AMP
RV101A	1	115	1	60	G	12	43	14/3	.33	1.0 -- 3.9	15 AMP
RV102	1	230	1	60	G	6	31.4	14/3	.33	3.5 -- 5.4	15 AMP
RV102A	1	230	1	60	G	6	31.4	14/3	.33	3.5 -- 5.4	15 AMP

Winding Resistance ± 5%  
Pump rated for operation at ± 10% voltage at motor.

Order Online: [www.PumpCatalog.com](http://www.PumpCatalog.com)

### RECEIVING/UNPACKING:

Upon receiving the pump, it should be inspected for damage or shortages. If damage has occurred, file a claim immediately with the company that delivered the pump. Unpack pump and record pump serial and model number before installing. If the manual is removed from the packaging, do not lose or misplace.

### STORAGE:

**Short Term-** For best results, pumps can be retained in storage, as factory assembled, in a dry atmosphere with constant temperatures for up to six (6) months.

**Long Term-** Any length of time exceeding six (6) months, but not more than twenty-four (24) months. The units should be stored in a temperature controlled area, a roofed over walled enclosure that provides protection from the elements (rain, snow, wind-blown dust, etc.), and whose temperature can be maintained between +40 deg. F and +120 deg. F. If extended high humidity is expected to be a problem, all exposed parts should be inspected before storage and all surfaces that have the paint scratched, damaged, or worn should be recoated with a air dry enamel paint. All surfaces should then be sprayed with a rust-inhibiting oil. Pump should be stored in its original shipping container. On initial start up, rotate impeller by hand to assure seal and impeller rotate freely. If it is required that the pump be installed and tested before the long term storage begins, such installation will be allowed provided:

- 1.) The pump is not installed under water for more than one (1) month.
- 2.) Immediately upon satisfactory completion of the test, the pump is removed, thoroughly dried, repacked in the original shipping container, and placed in a temperature controlled storage area.
- 3.) Before placing pump into service, pump should be brought to operational temperature range. Excessive or direct heating or cooling should NOT be used.

**OPERATION TEMPERATURE RANGE:** +35°F (2°C) to 104°F (40°C).

### SERVICE CENTERS:

For the location of the nearest Barnes Service Center, check your Barnes representative or Crane Pumps & Systems, Inc. Service Department in Piqua, Ohio, telephone (937) 778-8947 or in Brampton, Ontario, Canada (905) 457-6223.

### INSTALLATION:

**Location** - The pump is designed to fit into your basin either by sliding down the rail assembly, or by being mounted on a pump base.

**Submergence** - The pump should always be operated in the submerged condition. The minimum sump liquid level should never be less than A Dimension, A= 6.50 inches on RV Series pump bottom.

FIGURE 1

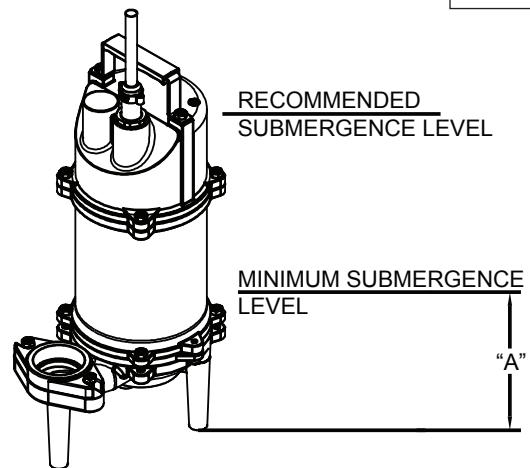

**Discharge** - Assemble discharge piping or hose assembly (whichever is required by your application), to the pump. Discharge piping should be as short as possible. Both a check valve and a shut-off valve are required for each pump being used. The check valve is used to prevent backflow into the sump. Excessive backflow can cause flooding and/or damage to the pump. The shut-off valve is used to stop system flow during pump or check valve servicing. An anti-siphon valve is also required.

**Package Systems**- Refer to manual supplied with basin package system.

### C-3) Liquid Level Controls

Figure 2 shows a typical installation for any submersible pump using a level control mounted to the discharge piping with a piggy-back plug.

### General Comments:

- 1) Never work in the sump with the power on.
- 2) Level controls are factory set for a pumping differential of 9 inches. If that is the cycle desired, simply circle the discharge pipe with the pipe mounting strap, feed the end through the worm drive, and tighten with a screwdriver. Be certain that the level control cannot hang up or foul in its swing. Also, make certain the pump impeller is still submerged when the level control is in the "OFF" mode.
- 3) If a higher pump differential is needed, grip the cord near the neck of the float, then using the other hand, exert a steady force on the lower edge of the cable clamp. The cable clamp should slide up to the new pivot point. Attach the level control to the discharge hose in the manner described above.
- 4) Plug the level control plug into the GFI receptacle, then plug the pump into the piggyback plug. One cycle of operation should be observed, so that any potential problems can be corrected.
- 5) It is recommended that the float should be set to insure that the sump well liquid level never drops below the top of the motor housing or a minimum level of 6.50 inches on RV Series above the pump bottom.

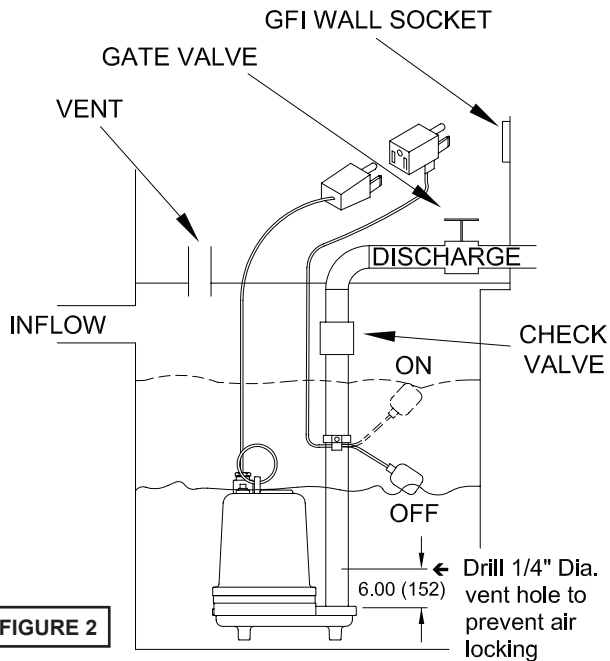

**FIGURE 2**

6.) Figure 3 shows a typical connection for pumps with the wide angle float and piggy-back plug, for manual and automatic operations.

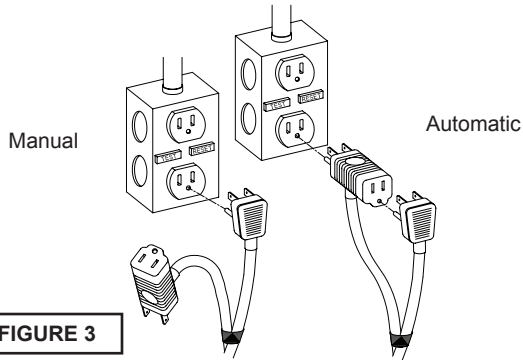

**FIGURE 3**

**Automatic** - Plug float cord into GFI outlet, then plug pump cord into float cord.

**Manual** - Plug pump cord directly into GFI outlet.

**ELECTRICAL CONNECTIONS:**

**Power Cable:**

The cord assembly mounted to the pump must not be modified in any way except for shortening to a specific application. Any splice between the pump and the control panel must be made in accordance with local electric codes. It is recommended that a junction box, if used, be mounted outside the sump or be of at least NEMA 4 (EEMAC-4) construction if located within the wet well. Do not use the power cable to lift pump.

**WARNING!** - The white wire is not a neutral or ground lead, but a power carrying conductor.

**Overload Protection:**

**Single Phase** - The type of in-winding overload protector used is referred to as an inherent overheating protector and operates on the combined effect of temperature and current. This means that the overload protector will trip out and shut the pump off if the windings become too hot, or the load current passing through them becomes too high. It will then automatically reset and start the pump up after the motor cools to a safe temperature. In the event of an overload, the source of this condition should be determined and rectified immediately. **DO NOT LET THE PUMP CYCLE OR RUN IF AN OVERLOAD CONDITION OCCURS !**

If current through the temperature sensor exceeds the values listed, an intermediate control circuit relay must be used to reduce the current or the sensor will not work properly.

TEMPERATURE SENSOR ELECTRICAL RATINGS		
Volts	Continuous Amperes	Inrush Amperes
110-120	3.00	30.0

**Wire Size:**

Consult a qualified electrician for proper wire size. See table for electrical information.

**SERVICE AND REPAIR**

**NOTE:** All item numbers ( ) refer to Figure 8.

**Lubrication:**

Anytime the pump is removed from operation, the cooling oil in the motor housing must be checked visually for oil level and contamination.

**STEPS & TIPS:**

- Disconnect all power supplied to panel prior to servicing.
- Remove existing circuit breaker from control panel if rating is less than 20 AMPS.
- Install new circuit breaker to control panel (2 Pole 20 AMP) (Ordered Separately).
- Rewire existing power supplied to control panel if required.

**WIRE FEEDING THE PANEL NEEDS TO BE AT LEAST 12 GAUGE. (MAY NEED TO BE LARGER DEPENDING UPON LENGTH OF RUN. CONSULT QUALIFIED ELECTRICIAN FOR PROPER APPLICATION.)**

### ORDERING REPLACEMENT PARTS:

When ordering replacement parts, ALWAYS furnish the following information:

1. Pump Part Number
2. Pump model number
3. Pump date code

<b>CRANE</b> PUMPS & SYSTEMS Piquette, Ohio MADE IN CHINA	HP.	Volts	Code	Ph.	Hz.
	1	115	G	1	60
	RPM	FLA	Model No.		
	3450	12	RV101		
	Part No.		Serial No.		
145469					
Impeller Dia.	Max. Liq. Temp.	Ins. Class			
4.313 IN	40 °C	F			
WARNING TO REDUCE RISK OF ELECTRICAL SHOCK, DISCONNECT THE PUMP FROM THE POWER SOURCE BEFORE HANDLING OR SERVICING. SEE INSTRUCTION MANUAL FOR PROPER INSTALLATION. SEE WARNING PLATE FOR ADDITIONAL CAUTIONS.					
 C US CSA 108 UL 778 LR 16567					
105500-41C					

<b>CRANE</b> PUMPS & SYSTEMS Piquette, Ohio MADE IN CHINA	HP.	Volts	Code	Ph.	Hz.
	1	230	G	1	60
	RPM	FLA	Model No.		
	3450	6	RV102		
	Part No.		Serial No.		
145470					
Impeller Dia.	Max. Liq. Temp.	Ins. Class			
4.313 IN	40 °C	F			
WARNING TO REDUCE RISK OF ELECTRICAL SHOCK, DISCONNECT THE PUMP FROM THE POWER SOURCE BEFORE HANDLING OR SERVICING. SEE INSTRUCTION MANUAL FOR PROPER INSTALLATION. SEE WARNING PLATE FOR ADDITIONAL CAUTIONS.					
 C US CSA 108 UL 778 LR 16567					
105500-41C					

#### Part Number:

The part number consists of a six (6) digit number, which appears in the catalog. A one or two letter suffix may follow this number to designate the design configuration. This number is used for ordering and obtaining information.

#### Model Number:

This designation consists of numbers and letters which represents the horsepower, motor phase and voltage, and pump design. This number is used for ordering and obtaining information.

#### Date Code:

The Date Code consists of two numbers which are punched holes in the nameplate. This specifies the month and year which indicates the date the unit was built.

## TROUBLE SHOOTING

**CAUTION !** Always disconnect the pump from the electrical power source before handling.  
 If the system fails to operate properly, carefully read instructions and perform maintenance recommendations.  
 If operating problems persist, the following chart may be of assistance in identifying and correcting them:  
**MATCH "CAUSE" NUMBER WITH CORRELATING "CORRECTION" NUMBER.**

**NOTE:** Not all problems and corrections will apply to each pump model.

PROBLEM	CAUSE	CORRECTION
Pump will not run	<ol style="list-style-type: none"> <li>1. Poor electrical connection, blown fuse, tripped breaker or other interruption of power, improper power supply.</li> <li>2. Motor or switch inoperative (to isolate cause, go to manual operation of pump).                             <ol style="list-style-type: none"> <li>2a. Float movement restricted.</li> <li>2b. Switch will not activate pump or is defective.</li> <li>2c. Insufficient liquid level.</li> <li>2d. Switch is unable to activate</li> </ol> </li> </ol>	<ol style="list-style-type: none"> <li>1. Check all electrical connections for security. Have electrician measure current in motor leads, if current is within <math>\pm 20\%</math> of locked rotor Amps, impeller is probably locked. If current is 0, overload may be tripped. Remove power, allow pump to cool, then recheck current.</li> <li>2a. Reposition pump or clean basin as required to provide adequate clearance for float.</li> </ol>
Pump will not turn off	<ol style="list-style-type: none"> <li>2a. Float movement restricted.</li> <li>2b. Switch will not activate pump or is defective.</li> <li>4. Excessive inflow or pump not properly sized for application.</li> <li>9. Pump may be airlocked.</li> <li>14. H-O-A switch on panel is in "HAND" position</li> </ol>	<ol style="list-style-type: none"> <li>2b. Disconnect level control. Set ohmmeter for a low range, such as 100 ohms full scale and connect to level control leads. Actuate level control manually and check to see that ohmmeter shows zero ohms for closed switch and full scale for open switch. (Float Switch).</li> <li>3a. Make sure liquid level is at least equal to suggested turn-on point.</li> <li>3b. Rotate ESPS level control in horizontal position.</li> </ol>
Pump hums but does not run	<ol style="list-style-type: none"> <li>1. Incorrect voltage</li> <li>8. Cutter jammed or loose on shaft, worn or damaged, inlet plugged.</li> </ol>	<ol style="list-style-type: none"> <li>4. Recheck all sizing calculations to determine proper pump size.</li> </ol>
Pump delivers insufficient capacity	<ol style="list-style-type: none"> <li>1. Incorrect voltage.</li> <li>4. Excessive inflow or pump not properly sized for application.</li> <li>5. Discharge restricted.</li> <li>6. Check valve stuck closed or installed backwards.</li> <li>7. Shut-off valve closed.</li> <li>8. Cutter jammed or loose on shaft, worn or damaged, inlet plugged.</li> <li>9. Pump may be airlocked.</li> <li>10. Pump stator damaged/torn.</li> </ol>	<ol style="list-style-type: none"> <li>5. Check discharge line for restrictions, including ice if line passes through or into cold areas.</li> <li>6. Remove and examine check valve for proper installation and freedom of operation.</li> <li>7. Open valve.</li> <li>8. Check cutter for freedom of operation, security and condition. Clean cutter and inlet of any obstruction.</li> <li>9. Loosen union slightly to allow trapped air to escape. Verify that turn-off level of switch is set so that the suction is always flooded. Clean vent hole.</li> </ol>
Pump cycles too frequently or runs periodically when fixtures are not in use	<ol style="list-style-type: none"> <li>6. Check valve stuck closed or installed backwards.</li> <li>11. Fixtures are leaking.</li> <li>15. Ground water entering basin.</li> </ol>	<ol style="list-style-type: none"> <li>10. Remove &amp; examine for damage. Replace pump stator if required.</li> <li>11. Repair fixtures as required to eliminate leakage.</li> </ol>
Pump shuts off and turns on independent of switch, (trips thermal overload protector). <b>CAUTION!</b> Pump may start unexpectedly. Disconnect power supply.	<ol style="list-style-type: none"> <li>1. Incorrect voltage.</li> <li>4. Excessive inflow or pump not properly sized for application.</li> <li>8. Cutter jammed, loose on shaft, worn or damaged, inlet plugged.</li> <li>12. Excessive water temperature.</li> </ol>	<ol style="list-style-type: none"> <li>12. Check pump temperature limits &amp; fluid temperature.</li> <li>13. Replace portion of discharge pipe with flexible connector.</li> <li>14. Turn to automatic position.</li> </ol>
Pump operates noisily or vibrates excessively	<ol style="list-style-type: none"> <li>4. Operating at too high a pressure.</li> <li>5. Discharge restricted.</li> <li>8. Cutter broken.</li> <li>13. Piping attachments to building structure too rigid or too loose.</li> </ol>	<ol style="list-style-type: none"> <li>15. Check for leaks around basin inlet and outlets.</li> </ol>

**IMPORTANT!  
WARRANTY REGISTRATION**

Your product is covered by a warranty:

[www.cranepumps.com/downloadables/CATALOGS\\_OIPMs/Warranty/24MonthWarranty.pdf](http://www.cranepumps.com/downloadables/CATALOGS_OIPMs/Warranty/24MonthWarranty.pdf)

If you have a claim under the provisions of the warranty, contact your local  
Crane Pumps & Systems, Inc. Distributor.

**RETURNED GOODS**

**RETURN OF MERCHANDISE REQUIRES A "RETURNED GOODS AUTHORIZATION".  
CONTACT YOUR LOCAL CRANE PUMPS & SYSTEMS, INC. DISTRIBUTOR.**



**Products Returned Must Be Cleaned, Sanitized,  
Or Decontaminated As Necessary Prior To Shipment,  
To Insure That Employees Will Not Be Exposed To Health  
Hazards In Handling Said Material. All Applicable Laws  
And Regulations Shall Apply.**

