

xylem
Let's Solve Water

TECHNICAL BROCHURE

B3INGFKV R2



3" GFK & GFV Series

SUBMERSIBLE SEWAGE PUMPS

 **GOULDS**
WATER TECHNOLOGY
a xylem brand

Order Online: www.PumpCatalog.com

FEATURES

SELF-CLEANING: The patented design of the self-cleaning K-impeller has been proven to reduce clogging and maintain efficiency when pumping wastewater

SOLIDS HANDLING: The vortex impeller can handle solids up to 3" in size and resists clogging better than a traditional two-vane impeller

POWERFUL: An efficient air-filled motor provides built-in thermal overload protection allowing the pump to run continuously without overheating

ROBUST: Components are made from robust cast iron for long life and easy maintenance

DURABLE: Heavy-duty long life bearings provide peace of mind

SMOOTH: The double mechanical seal provides extra reliability and protects against leakage*

INSTALLATION OPTIONS: Pump has built-in dual seal and sensors for high temperature and seal leak detection which accommodate upgraded panel installations*

* Upgraded installation required for seal leak detection

APPLICATIONS

Used in a variety of residential, commercial and industrial applications such as:

- Sewage systems
- Flood and pollution control
- Dewatering/effluent
- Farms
- Hospitals
- Trailer courts
- Motels

SPECIFICATIONS

- **Capacities:**
3" Series: Up to 560 gpm
- **Total head:**
3" Series: Up to 157 feet TDH
- **Horsepower:**
3" Series: Up to 11 hp
- **Discharge size:**
3" Series: 3" ANSI flange

- **Insulation:** Class F: 310° F (155° C)
- **Maximum Fluid Temperature:** 104° F (40° C)
- **Phase:** Three-phase
- **Frequency:** 60 Hz
- **Impeller:**
GFK Series: Self-cleaning K-impeller
GFV Series: Vortex impeller
- **Motor:** Air-filled 3400 rpm motor with built-in thermal overload protection
- **Bearings:** Single row ball bearings
- **Upper-Lower Seal Configurations (configurations vary by model):**
 - Carbon/Aluminum Oxide - Aluminum Oxide/WCCR
 - Carbon/WCCR - WCCR/WCCR
- **Cable Length:** 50 ft (16 m) power cord

AGENCY LISTINGS



Tested to UL 778 and CSA 22.2 108 standards by Canadian Standards Association



Upgraded installation requires MiniCAS module in control panel.

PRODUCT SPECIFICATIONS

GWT Part No.	HP	Phase	Hz	Voltage	Max Amps	Weight (lbs.)				
3GFV9512N	9.5	3	60	200	26	287				
3GFV9513N				230	23					
3GFV9514N				460	12					
3GFV9515N				575	9.9					
3GFK9512M	9.5			3	60	200	26	287		
3GFK9513M						230	23			
3GFK9514M						460	12			
3GFK9515M						575	9.9			
3GFK1112L	11					3	60	200	30	287
3GFK1113L								230	26	
3GFK1114L								460	13	
3GFK1115L								575	11	

PERFORMANCE CURVES

3" GFV 9.5 HP - N

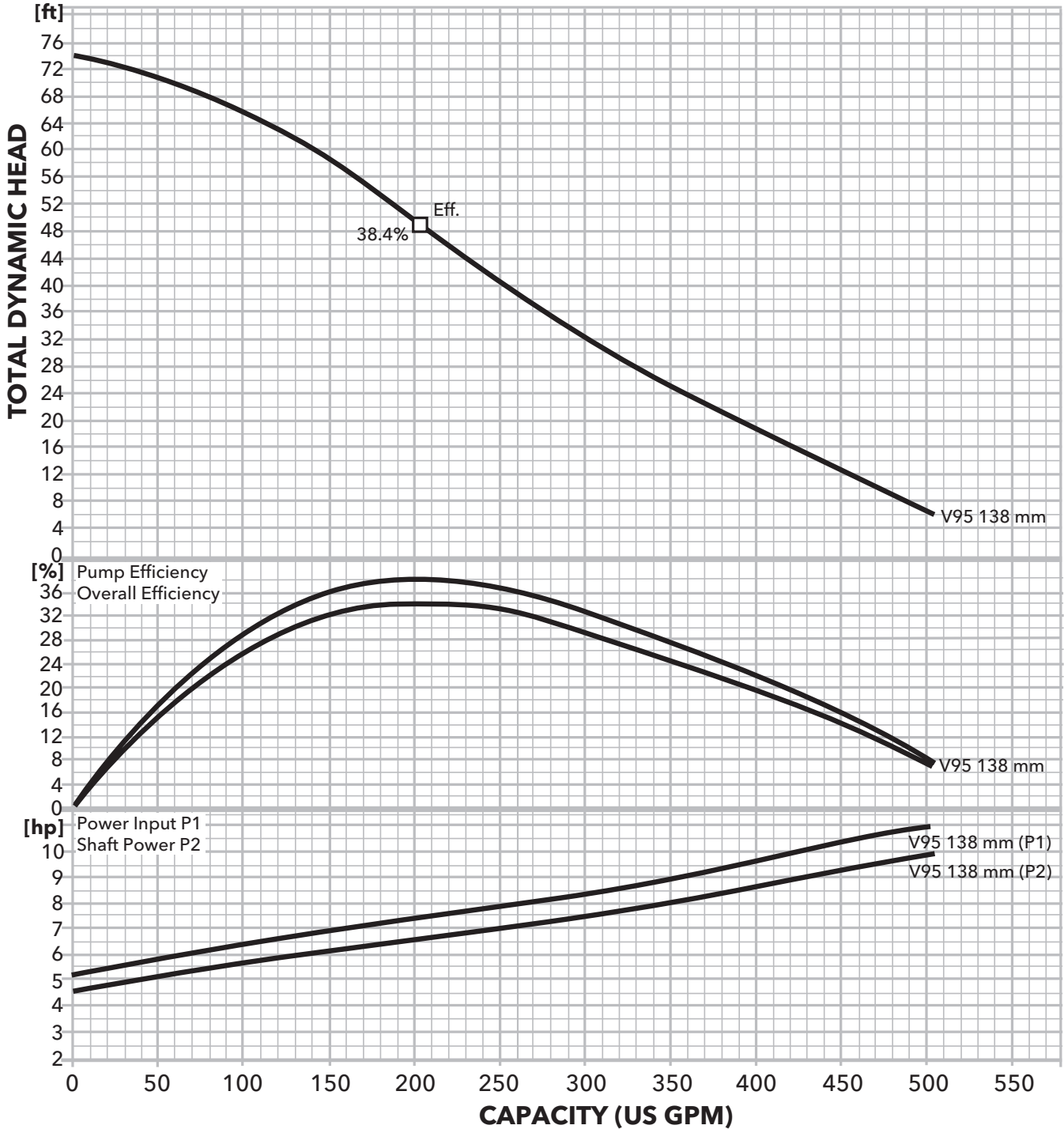

PERFORMANCE CURVES

3" GFK 9.5 HP - M

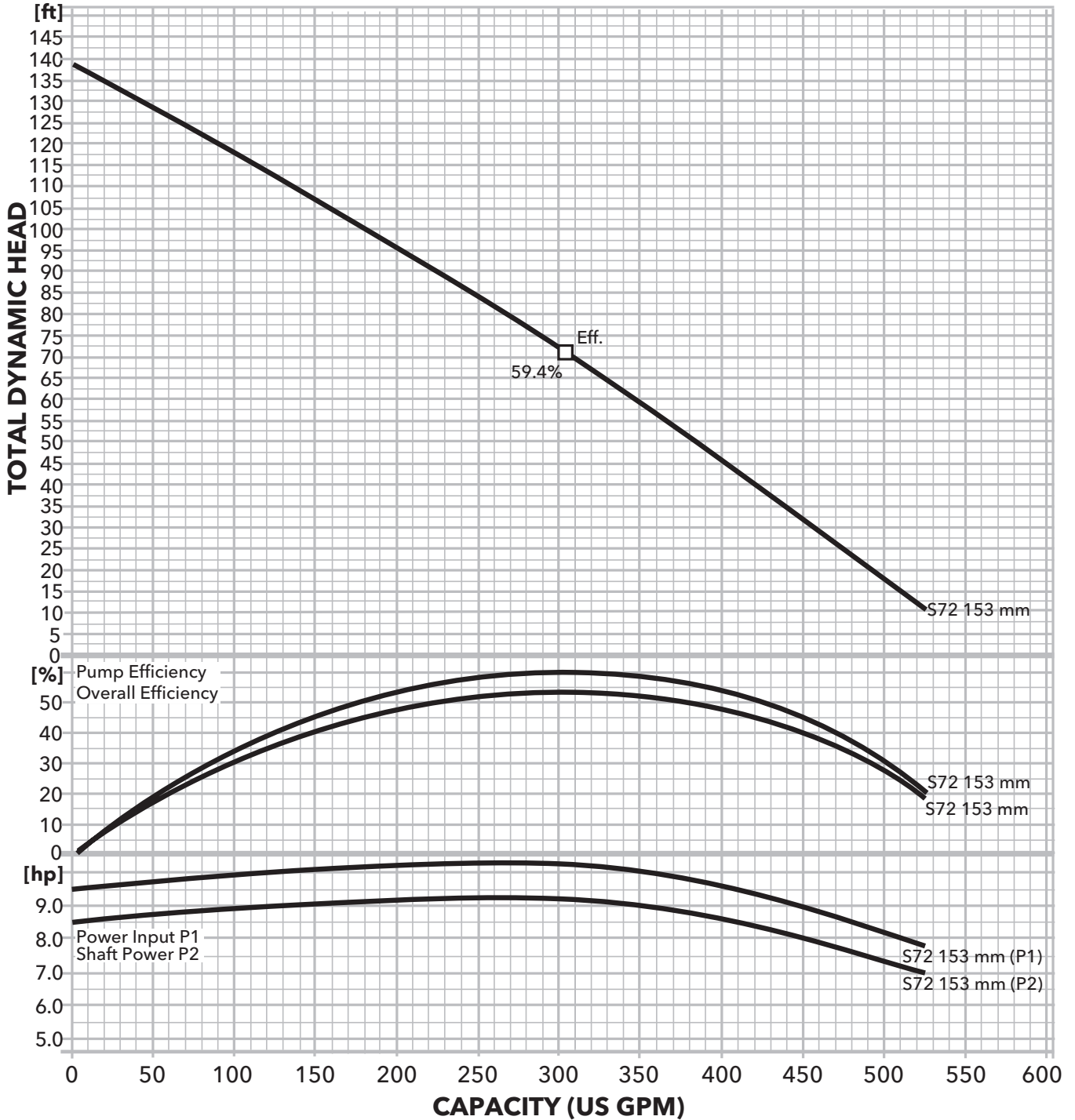

PERFORMANCE CURVES

3" GFK 11 HP - L

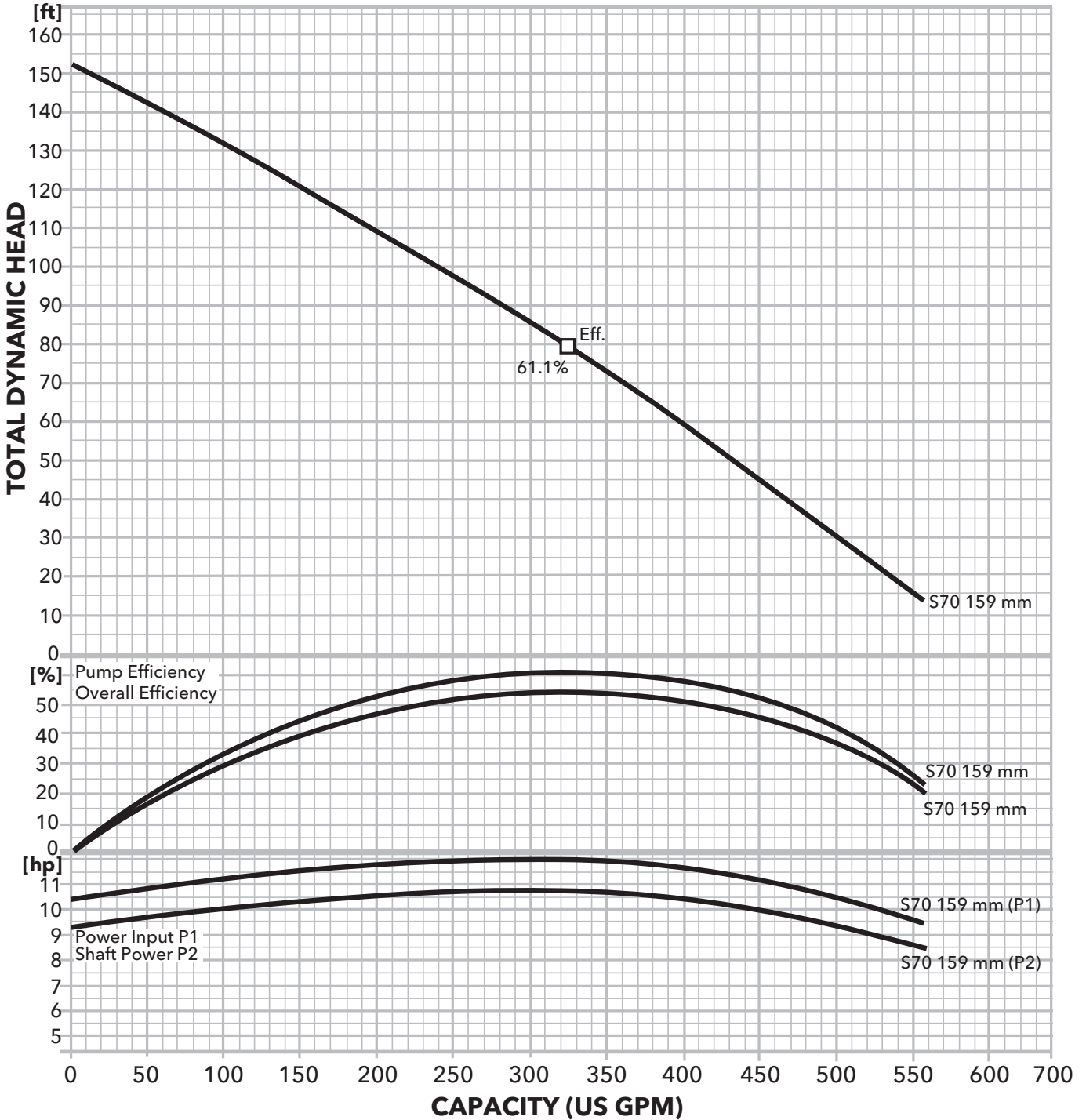

3" DIMENSIONS

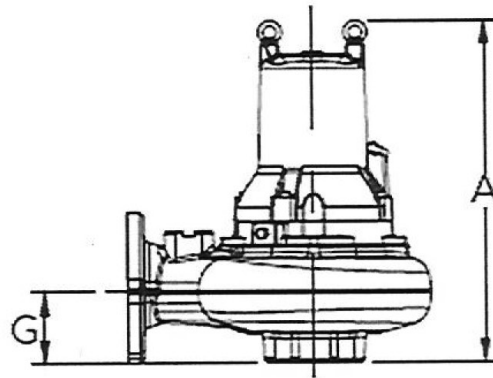
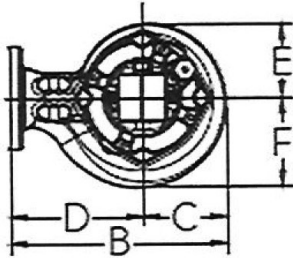

3GFV95

- A = 23.31"
- B = 20.49"
- C = 8.39"
- D = 12.21"
- E = 7.64"
- F = 9.13"
- G = 4.61"

3GFK95 3GFK11

- A = 22.44"
- B = 16.73"
- C = 6.50"
- D = 10.24"
- E = 5.95"
- F = 6.77"
- G = 3.54"

Xylem |'zīləm|

- 1) The tissue in plants that brings water upward from the roots;
- 2) a leading global water technology company.

We're a global team unified in a common purpose: creating advanced technology solutions to the world's water challenges. Developing new technologies that will improve the way water is used, conserved, and re-used in the future is central to our work. Our products and services move, treat, analyze, monitor and return water to the environment, in public utility, industrial, residential and commercial building services settings. Xylem also provides a leading portfolio of smart metering, network technologies and advanced analytics solutions for water, electric and gas utilities. In more than 150 countries, we have strong, long-standing relationships with customers who know us for our powerful combination of leading product brands and applications expertise with a strong focus on developing comprehensive, sustainable solutions.

For more information on how Xylem can help you, go to www.xylem.com

xylem
Let's Solve Water

Xylem Inc.
Phone: (866) 325-4210
Fax: (888) 322-5877
www.xylem.com/goulds

Goulds is a registered trademark of Goulds Pumps, Inc. and is used under license.
© 2020 Xylem Inc. B3INGFKV R2 October 2020

Order Online: www.PumpCatalog.com