

DTS

Configurable Dosing Tank Stations



be
think
innovate

GRUNDFOS 

1. General data	3
2. Type key description code	4
3. Components	5
Tank	5
4. Tank Dimensions	7
5. Accessories/Materials	8
6. Further product documentation	9
WebCAPS	9
WinCAPS	10

1. General data

Dosing tank stations are designed for long-term storage of liquid chemicals and providing a platform for dosing equipment. They can be configured with the type key on page 3 and are able to fulfill a variety of dosing tasks. Thanks to the use of high quality materials, dosing tank stations can be applied universally for many dosing liquids – the material selection can be adapted with the configuration.

Components and characteristics:

Dosing tank systems can include the following:

1. Chemically-resistant tank made of UV-stabilized, semi-transparent or black polyethylene, in 6 sizes from 15 to 264 gallons, sintered bushings or adapter plate for installation of a dosing pump
2. Hand or electric mixer
3. Electric mixer level switch
4. Flexible or rigid suction line made of PVC or PP, with foot valve and two-step level switch for switchoff in connection with separate control
5. Injection unit made of PVC or PP
6. 20' of discharge line made of PE or PVC
7. Drain Valve (not shown)
8. Fill valve (not shown)
9. Multifunction valve (not shown)
10. Prepared for the installation of a dosing pump: bushings and adapter plate (if necessary), including mounting parts
11. Dosing pumps are not included in a standard delivery. They can be selected according to requirements from the ranges of DDA, DDC, DDE, DME and DDI and have to be ordered separately. For more detailed information on dosing pumps, please see the respective Data Booklet.

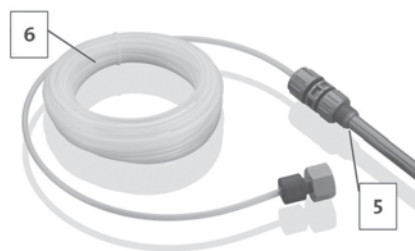

Fig. 1

TM05 8311 0513

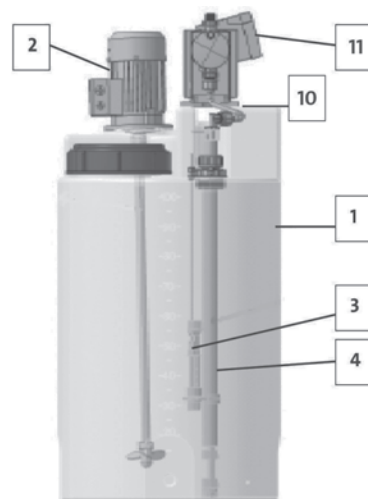

Fig. 2

TM05 8310 0513

2. Type key description code

Selected product: DTS 132G T 0 0 0 4 RE F 4 A 1 H

Product type

DTS Dosing tank station

Tank size

15G 15 gallons

26G 26 gallons

52G 52 gallons

79G 79 gallons

132G 132 gallons

264G 264 gallons

Tank color

T Transparent tank with black lid

B Black tank with black lid

Containment unit

0 Without containment unit

1 With containment unit

Screw cover

0 Screw cover without lock

Electric or manual mixer*

0 Without mixer

1 With handmixer PVC

2 With electric mixer stainless steel

3 With electric mixer PP with sealing flange

Dosing pump type preparation**

0 Without preparation

1 For DMX 221 up to 50 l/h

3 For DDI 60-10

4 For Smart Digital DDA, DDC and DDE

*** Electric mixer motors are generally single phase, voltages and frequencies are:**

220-230 (224)V 50/60 Hz for liter tanks

115/208-230V 60 Hz for gallon tanks

****Dosing pump type preparation has influence on hose dimensions:**

DDI60-10 comes with PE-hose 9/12 for liter tanks and PE-hose 3/8" x 1/2" for gallon tanks (suction hose). All other selections have as suction hose PE-hose 6/9 (liter) or PE-hose 1/4" x 3/8" (gallon). Discharge tubing PE-hose 4/6 mm (or 0.17" x 1/4" for gallon tanks) is only selectable for Smart Digital. Please check max. allowable flow rate.

*****Injection unit process connection is depending on tank selection**

Liter tanks come with G1/2" process connection

Gallon tanks come with 1/2" NPT process connection

Multifunction valve

A Without multifunction valve

G With multifunction valve PV/V

H With multifunction valve PV/E

I With multifunction valve PV/T

Filling armature

0 Without filling armature

1 With filling armature PVC/E with ball valve

2 With dissolving hopper

Drain valve

A Without drain valve

B With drain valve PVC/E

Injection unit***

0 Without injection unit

1 With injection unit PVC/V/C

2 With injection unit PP/V/C

3 With injection unit PVC/E/C

4 With injection unit PP/E/C

5 With injection unit PVC/T/C

Discharge line

F 33 ft. PE-tubing 0.17" x 1/4" (up to 2 gph)

G 33 ft. PE-tubing 1/4" x 3/8" (up to 8 gph)

H 33 ft. PE-tubing 3/8" x 1/2" (up to 15.8 gph)

Suction line

WO Without suction line

RV With rigid suction lance PE/V

RE With rigid suction lance PE/E

RT With rigid suction lance PE/T

FV With flexible suction line PE/V

FE With flexible suction line PE/E

FT With flexible suction line PE/T

3. Components

Tank

Cylindrical container in 6 sizes from 15 to 264 gallons, PE, transparent or black, with screw cover without lock, sintered bushings for installation of a SMART Digital, DDI DMX dosing pump or for a DME pump with adapter plate.

Temperature Range	Min. -4°F
	Max. 113°F

Hand Mixer

PVC, for mixing the solution in the tank (for tanks up to 79 gallons)

Description

The length is adapted to the tank size before delivery

Electric Mixer

To obtain a homogeneous mixture in the tank, for tanks of 15 to 264 gallons

Motor details:

- .25 Hp, 1725 RPM, 1 Ph, 60 Hz, 56C, 3411L, TEFC, F1
- .75 Hp, 1725 RPM, 1 Ph, 60 Hz, 56C, 3428LC, TEFC

Description

Stainless steel version for aggressive liquids

- Shaft and mixing propeller 316 Ti (1.4571)

Plastic version for degassing liquids

- Shaft PP-coated, mixing propeller PP
- Sealing flange fixed at the motor flange for application with degassing liquids

Foot Valve

Foot valves are installed at the lower end of the suction hose and are available with or without level indication

Foot valve without level indication

Stainless steel version for aggressive liquids

- Includes weight, strainer, check valve, hose connection set

Foot valve with level indication

- Includes reed-switch unit with two floats, 16' of cable with PE jacket, M12 plug to connect to DDA, DDC, DDE or DDI pump, PE cap
- Switch mode of low-level and empty indication is factory set to NO; switch can be set to NC by turning floats upside down
- Electrical data is:
 - Max. voltage - 48V
 - Max. current - 0.5A
 - Max. load - 10VA

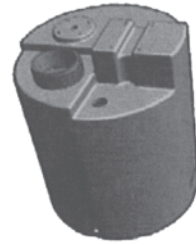

TM05 8453 0613

Fig. 3



TM04 8521 1012

Fig. 4



TM04 1687

Fig. 5



TM04 8713

Fig. 6

Rigid Suction Lance

Rigid suction lances are installed at the lower end of the suction hose when a mixer is used and include level indication

Rigid suction lance with level indication

- Includes reed-switch unit with two floats, 16' of cable with PE jacket, M12 plug to connect to DDA, DDC, DDE or DDI pump, PE cap
- Switch mode of low-level and empty indication is factory set to NO; switch can be set to NC by turning floats upside down
- Electrical data is:
 - Max. voltage - 48V
 - Max. current - 0.5A
 - Max. load - 10VA

Injection Valves

Injection valves connect the dosing line to the process line. They ensure a minimum backpressure of 10 psi and avoid backflow of the dosing liquid

Description

They generally include:

- Injection pipe, PP, PVC and PVDF versions, which can be shortened
- Spring-loaded check valve with Tantal spring
- Hose connection set
- Pipe connection set

Drain Valve

Description

PVC, 3/4", EPDM gasket for installation in the threaded drain port of the tank

Fill Valve

Description

PVC, 3/4", EPDM gasket

Multifunction Valve

Description

- For pressure build-up, pressure retention, pressure relief, for deaeration of the dosing head and for draining the discharge line
- PVDF valve body, PVC connections, FKM gasket
- Hose connection set



Fig. 7

TM04 8712



Fig. 8

TM04 8157



Fig. 9

TM04 8158



Fig. 10

TM04 8159



Fig. 11

TM04 8160

4. Tank Dimensions

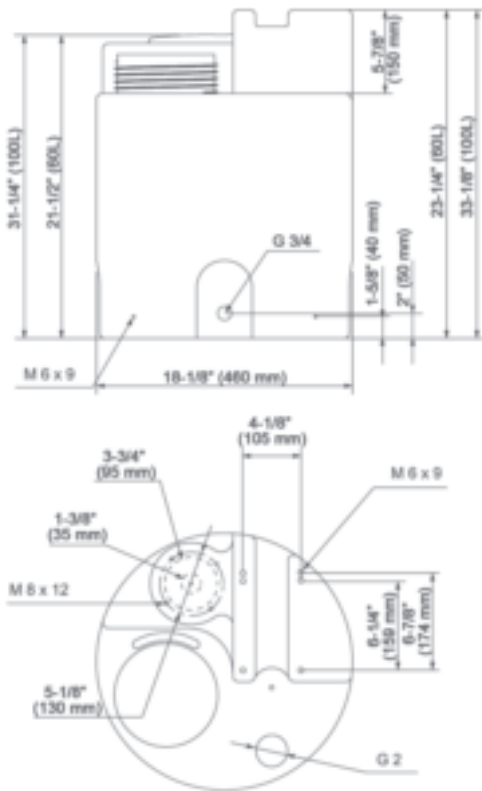

Fig. 12 Cylindrical tank, 15 gal. [60L] and 26 gal. [100L]

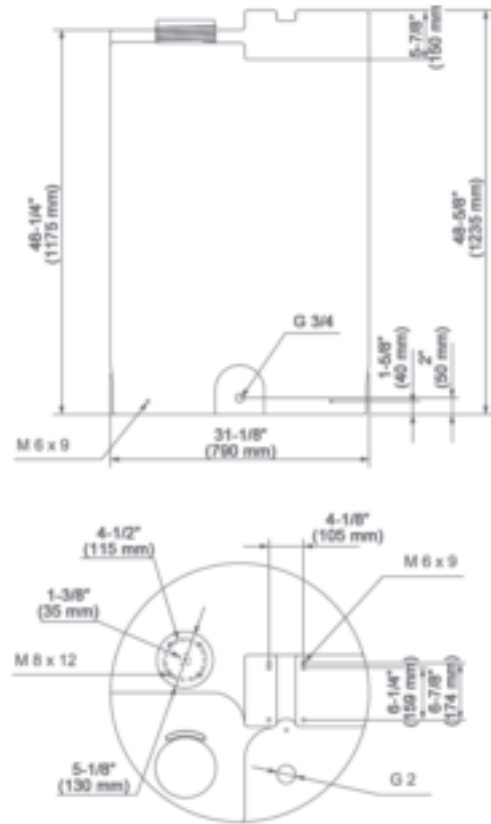

Fig. 14 Cylindrical tank, 132 gal. [500L]

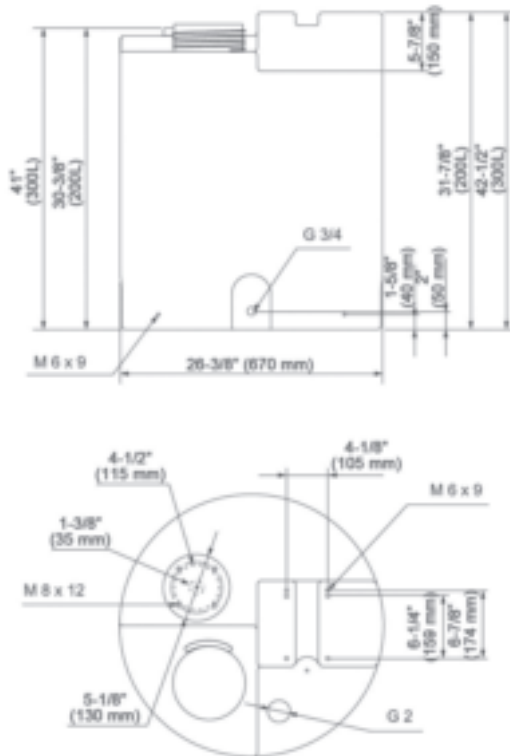

Fig. 13 Cylindrical tank, 53 gal. [200L] and 79 gal. [300L]



Fig. 15 Cylindrical tank, 264 gal. [1000L]

TM04 8465_US 0113

TM04 8467_US 0113

TM04 8466_US 0113

TM04 8315_US 0113

5. Accessories/Materials

Accessories

Description	Material	Product Number
Drain Valve for installation in threaded bottom fitting of tank	PVC	96689132
Dissolving Hopper for washing powders into the dosing tank	PVC	96726979
Handheld Mixer for use in dosing tanks	PE	98133793
Set of (4) floor-mounting brackets with screws		98149921
Set of screws for mounting pump on 15, 26, 52, 79, 132 or 264 gallon tank	SS	98159495

Selection of material combinations

Dosing tank systems are suitable for the chemicals described in the table below. The material combination of the components can be chosen as follows:

Suitable for:	Possible material combination of dosing head and accessories*
Sodium hypochlorite (NaClO)	PVC/N/C, PVC/N/G, PVC/T/T
Sulphuric acid (H ₂ SO ₄) up to 80%	PVC/N/C, PVC/N/G, PVC/T/T, PP/N/C
Hydrogen peroxide (H ₂ O ₂)	PVC/N/C, PVC/N/G, PP/N/C
Antiscalants	PVC/N/C, PVC/N/G, PVC/T/T, PP/N/C
Biocides	PVC/N/C, PVC/N/G, PVC/T/T, PP/N/C
Sodium Thiosulfate (Na ₂ S ₂ O ₃)	PVC/N/C, PVC/N/G, PVC/T/T, PP/N/C
Coagulants:	
Ferric (II/III) chloride	PVC/N/C, PVC/N/G, PVC/T/T, PP/N/C
Polyaluminum chloride (PAC)	
Polyaluminum sulfate	
Caustic soda (NaOH)	PP/E/C, PVC/E/C, PVC/E/SS, PVC/E/T
Caustic potash (KOH)	PP/E/C, PVC/E/C, PVC/E/SS, PVC/E/T
Potassium permanganate (KMnO ₄)	PP/E/C, PVC/E/C, PVC/E/T
Hydrochloric acid (HCl)	PVC/N/C, PVC/N/G, PP/E/C
Phosphoric acid (H ₃ PO ₄)	PVC/N/C, PVC/N/G, PVC/T/T, PP/N/C

*Standard combinations are bold

Material key for components in contact with liquid

Enclosure	Gaskets	Balls	Hoses	Elec. Mixers	Hand Mixer	Tank
PVC = PVC	V = FKM	C = Ceramics	PVC	PP = Polypropylene	PVC	PE
PP = Polypropylene	E = EPDM	G = Glass	PE	SS = Stainless steel		
	T = PTFE	T = PTFE				
		SS = Stainless steel				

6. Further product documentation

WebCAPS

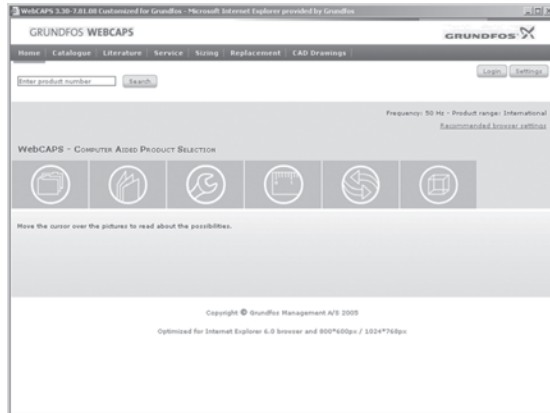

WebCAPS is a **Web-based Computer Aided Product Selection** program available on www.grundfos.com.

WebCAPS contains detailed information on more than 185 000 Grundfos products in more than 20 languages.

In WebCAPS, all information is divided into 6 sections:

- Catalogue
- Literature
- Service
- Sizing
- Replacement
- CAD drawings.

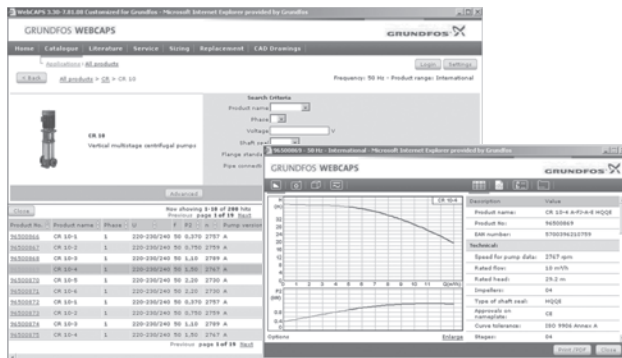

Catalogue

With a starting point in areas of applications and pump types, this section contains

- technical data
- curves (QH, Eta, P1, P2, etc) which can be adapted to the density and viscosity of the pumped liquid and show the number of pumps in operation
- product photos
- dimensional drawings
- wiring diagrams
- quotation texts, etc.

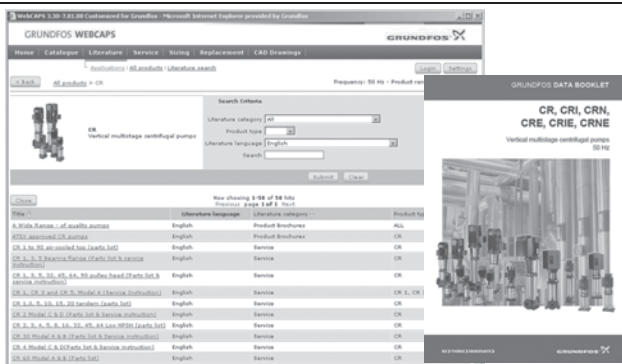

Literature

In this section you can access all the latest documents of a given pump, such as

- data booklets
- Installation and operating instructions
- service documentation, such as Service kit catalogue and Service kit instructions
- quick guides
- product brochures, etc.



Service

This section contains an easy-to-use interactive service catalogue. Here you can find and identify service parts of both existing and cancelled Grundfos pumps. Furthermore, this section contains service videos showing you how to replace service parts.



Sizing

With a starting point in different application areas and installation examples, this section gives easy step-by-step instructions in how to

- select the most suitable and efficient pump for your installation
- carry out advanced calculations based on energy consumption, payback periods, load profiles, lifecycle costs, etc.
- analyse your selected pump via the built-in lifecycle cost tool
- determine the flow velocity in wastewater applications, etc.

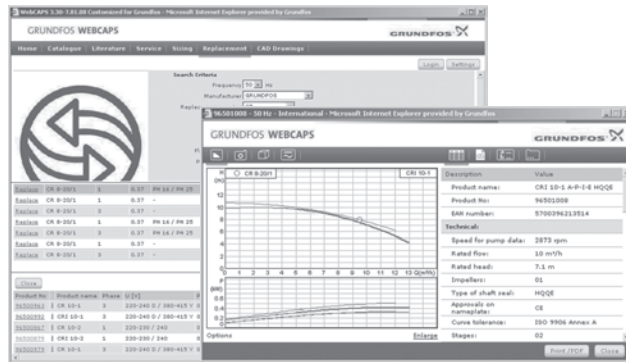

Replacement

In this section you find a guide to select and compare replacement data of an installed pump in order to replace the pump with a more efficient Grundfos pump.

The section contains replacement data of a wide range of pumps produced by other manufacturers than Grundfos.

Based on an easy step-by-step guide, you can compare Grundfos pumps with the one you have installed on your site. After having specified the installed pump, the guide suggests a number of Grundfos pumps which can improve both comfort and efficiency.



CAD drawings

In this section it is possible to download 2-dimensional (2D) and 3-dimensional (3D) CAD drawings of most Grundfos pumps.

The following formats are available in WebCAPS:

2-dimensional drawings

- .dxf, wireframe drawings
- .dwg, wireframe drawings.

3-dimensional drawings

- .dwg, wireframe drawings (without surfaces)
- .stp, solid drawings (with surfaces)
- .eprt, E-drawings.

WinCAPS



Fig. 16 WinCAPS CD-ROM

WinCAPS is a **Windows-based Computer Aided Product Selection** program containing detailed information on more than 185,000 Grundfos products in more than 22 languages.

The program contains the same features and functions as WebCAPS, but is an ideal solution if no Internet connection is available.

WinCAPS is available on CD-ROM and updated once a year.

98489994 0513

ECM:

USA

Grundfos Chicago

3905 Enterprise Court
P.O. Box 6620
Aurora, IL 60598-0620
Phone: +1-630-236-5500
Fax: +1-630-236-5511

USA

Grundfos Kansas City

17100 West 118th Terrace
Olathe, KS 66061
Phone: +1-913-227-3400
Fax: +1-913-227-3500

México

Bombas GRUNDFOS de México S.A. de C.V.

Boulevard TLC No. 15
Parque Industrial Stiva
Aeropuerto
Apodaca, N.L.C.P. 66600
Phone: +52-81-8144 4000

GRUNDFOS 