

# NBE, NBGE, NKE, NBSE; NBE, NBGE, NKE, NBSE Series 2000; VLSE

Installation and operating instructions



**NBE, NBGE, NKE, NBSE; NBE,  
NBGE, NKE, NBSE Series 2000;  
VLSE**

**Installation and operating instructions**  
(all available languages)

<http://net.grundfos.com/gr/i/93103355>



**NBE, NBGE, NKE, NBSE; NBE, NBGE, NKE, NBSE Series 2000;****VLSE**  
English (US)

---

Installation and operating instructions . . . . .	4
<b>Installation in the USA and Canada . . . . .</b>	<b>77</b>
<b>Installation aux États-Unis et au Canada . . . . .</b>	<b>80</b>
<b>Limited consumer warranty . . . . .</b>	<b>83</b>
<b>Limited manufacturer's warranty . . . . .</b>	<b>85</b>

## English (US) Installation and operating instructions

## Original installation and operating instructions

## Table of contents

<b>1. General information</b>	<b>5</b>	7.18 Limit-exceeded function	56
1.1 Hazard statements	5	7.19 Ramps	57
1.2 Notes	5	7.20 Skip band	57
1.3 Abbreviations and definitions	5	7.21 Standstill heating	57
<b>2. Product introduction</b>	<b>5</b>	7.22 Alarm handling	57
2.1 Related instructions	5	7.23 Motor bearing monitoring	57
2.2 Product description	5	7.24 Service	58
2.3 Intended use of the product	6	7.25 Communication	58
2.4 Identification of the motor model	6	<b>8. Safe Torque Off (STO) function</b>	<b>66</b>
2.5 Identification of the functional module	6	8.1 Identification of the Safe Torque Off (STO) function	66
2.6 Identification of the operating panel	6	<b>9. Servicing the product</b>	<b>66</b>
2.7 Cybersecurity	7	9.1 Cleaning the product	67
2.8 Radio modules	7	<b>10. Taking the product out of operation</b>	<b>68</b>
2.9 Battery	8	<b>11. Technical data</b>	<b>68</b>
<b>3. Receiving the product</b>	<b>8</b>	11.1 Technical data, three-phase motors	68
3.1 Transporting the product	8	11.2 Inputs and outputs	69
3.2 Inspecting the product	8	11.3 Other technical data	70
<b>4. Mechanical installation</b>	<b>9</b>	11.4 Operating conditions	75
4.1 Handling the product	9	<b>12. Disposing of the product</b>	<b>76</b>
4.2 Mounting the motor	9	<b>13. Document quality feedback</b>	<b>76</b>
4.3 Cable entries	9		
4.4 Cable glands	9		
4.5 Product installation	9		
4.6 Cooling the motor	10		
4.7 Installing the product in areas with high humidity	10		
4.8 Changing the position of the operating panel	10		
<b>5. Electrical connection</b>	<b>11</b>		
5.1 Electrical supply systems	11		
5.2 Protection against electric shock, indirect contact	11		
5.3 Cover for the power cables	11		
5.4 Protection against mains voltage transients	11		
5.5 Motor protection	11		
5.6 Connecting an external switch	11		
5.7 Cable requirements	12		
5.8 Additional protection	15		
<b>6. Control functions</b>	<b>26</b>		
6.1 User interfaces	26		
6.2 Grundfos GO	33		
6.3 Grundfos GO Link	37		
6.4 Grundfos Eye	38		
<b>7. Setting the product</b>	<b>40</b>		
7.1 Setpoint	40		
7.2 Operating mode	40		
7.3 Set manual speed	40		
7.4 Set user-defined speed	40		
7.5 Control mode	40		
7.6 Setting the proportional pressure	44		
7.7 Analog inputs	45		
7.8 Grundfos Direct Sensor	46		
7.9 Pt100/1000 inputs	47		
7.10 Digital inputs	47		
7.11 Digital inputs/outputs	49		
7.12 Signal relay (Relay outputs)	50		
7.13 Analog output	51		
7.14 Controller (Controller settings)	52		
7.15 Operating range	53		
7.16 External setpoint function	53		
7.17 Predefined setpoints	55		

## 1. General information



Read this document before you install the product. Installation and operation must comply with local regulations and accepted codes of good practice.

### 1.1 Hazard statements

The symbols and hazard statements below may appear in Grundfos installation and operating instructions, safety instructions and service instructions.



#### DANGER

Indicates a hazardous situation which, if not avoided, will result in death or serious personal injury.



#### WARNING

Indicates a hazardous situation which, if not avoided, could result in death or serious personal injury.



#### CAUTION

Indicates a hazardous situation which, if not avoided, could result in minor or moderate personal injury.

The hazard statements are structured in the following way:



#### SIGNAL WORD

##### Description of the hazard

Consequence of ignoring the warning

- Action to avoid the hazard.

### 1.2 Notes

The symbols and notes below may appear in Grundfos installation and operating instructions, safety instructions and service instructions.



Observe these instructions for explosion-proof products.



A blue or grey circle with a white graphical symbol indicates that an action must be taken.



A red or grey circle with a diagonal bar, possibly with a black graphical symbol, indicates that an action must not be taken or must be stopped.



If these instructions are not observed, it may result in malfunction or damage to the equipment.



Tips and advice that make the work easier.

### 1.3 Abbreviations and definitions

AI	Analog input.
AL	Alarm, out of range at lower limit.
AO	Analog output.
AU	Alarm, out of range at upper limit.
CIM	Communication interface module.
Current sinking	The ability to draw current into the terminal and guide it towards earth in the internal circuitry.
Current sourcing	The ability to push current out of the terminal and into an external load which must return it to earth.
DI	Digital input.

DO	Digital output.
ELCB	Earth leakage circuit breaker.
FM	Functional module.
GDS	Grundfos Digital Sensor, factory-fitted.
GENIbus	Proprietary Grundfos fieldbus standard.
GFCI	Ground fault circuit interrupter.
GND	Protective earth.
Grundfos Eye	Status indicator light.
LIVE	Low voltage with the risk of electric shock if the terminals are touched.
OC	Open collector: Configurable open-collector output.
PE	Protective earth.
RCCB	Residual-current circuit breaker.
RCD	Residual-current device.
SELV	Safety extra-low voltage. A voltage that cannot exceed ELV under normal conditions and under single-fault conditions, including earth faults in other circuits.
STO	Safe Torque Off. A sub safety function, where a drive does not actively generate any torque and coasts freely.

## 2. Product introduction

### 2.1 Related instructions



These installation and operating instructions are a supplement to the installation and operating instructions for the corresponding standard pumps NB, NK, NBS and VLS. For instructions not mentioned specifically in this manual, see the installation and operating instructions for the standard pump.

#### Installation and operating instructions

Title	QR code	Publication number	Link
VLS		98434722	<a href="http://net.grundfos.com/qr/i/98434722">http://net.grundfos.com/qr/i/98434722</a>
NB, NBG		93048247	<a href="http://net.grundfos.com/qr/i/93048247">http://net.grundfos.com/qr/i/93048247</a>
NK		93048245	<a href="http://net.grundfos.com/qr/i/93048245">http://net.grundfos.com/qr/i/93048245</a>
NBS		99932034	<a href="http://net.grundfos.com/qr/i/99932034">http://net.grundfos.com/qr/i/99932034</a>

### 2.2 Product description

Grundfos MLE 100-180 are frequency-controlled permanent-magnet motors for single-phase or three-phase mains connection. The motors incorporate a PI controller.

You can connect the motors to a signal from an external sensor and a setpoint signal enabling control in a closed loop. You can also use the motors for an open-loop system in which the setpoint signal is used as a speed-control signal.

The motors incorporate an operating panel which is available in various versions.

Detailed motor settings are made with Grundfos GO. Furthermore, you can read important operating parameters via Grundfos GO. The motors incorporate a functional module. The functional module is available in various versions with different inputs and outputs. You can fit the motors with a Grundfos add-on communication interface module (CIM). The module enables data transmission between the motor and an external system, for example a BMS or SCADA system. The module communicates via fieldbus protocols. You can connect several motors together via radio or bus communication to create a multimotor system.

### 2.3 Intended use of the product

Only use the product according to the specifications stated in the installation and operating instructions.

### 2.4 Identification of the motor model

Identify the motor by means of the nameplate on the terminal box.

#### Model J

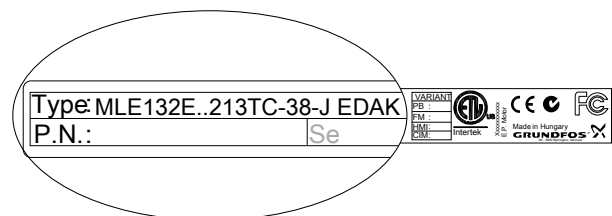

TM084776

Motor [HP]	3 × 440-480 V	3 × 200-240 V
	3500-4000/ 4000-5900 rpm	3400-4000 rpm
3	-	•
5	•	•
7 1/2	•	•
10	•	-
15	•	-

#### Model K

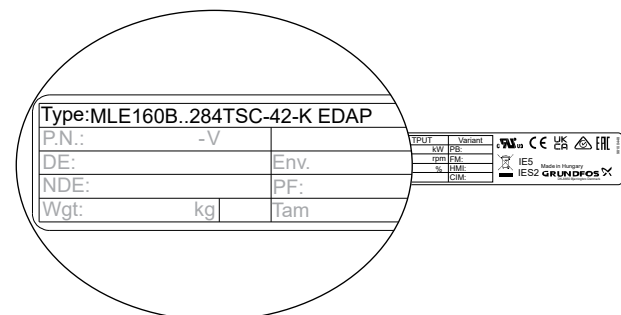

TM084775

Motor [HP]	3 × 440-480 V	3 × 200-240 V
	3500-4000 rpm	3400-4000 rpm
10	-	•
15	-	•
20	•	-
25	•	-
30	•	-

### 2.5 Identification of the functional module

You can identify the fitted module in one of the following ways:

#### Grundfos GO

You can identify the functional module in the **Fitted modules** menu under **Status**.

#### Motor display

For motors fitted with the HMI 300 or HMI 301 operating panel, you can identify the functional module in the **Fitted modules** menu under **Status**.

#### Motor nameplate

You can identify the fitted module by means of the data on the motor nameplate.

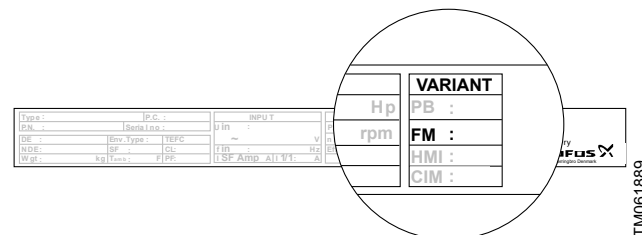

TM061889

#### Functional module variants:

- FM310
  - FM311 <sup>1)</sup>
- 1) Without Bluetooth (BLE).

### 2.6 Identification of the operating panel

You can identify the operating panel in one of the following ways:

#### Grundfos GO

You can identify the operating panel in the **Fitted modules** menu under **Status**.

#### Motor display

For motors fitted with the HMI 300 or 301 operating panel, you can identify the operating panel in the **Fitted modules** menu under **Status**.

#### Motor nameplate

You can identify the operating panel by means of the data on the motor nameplate.

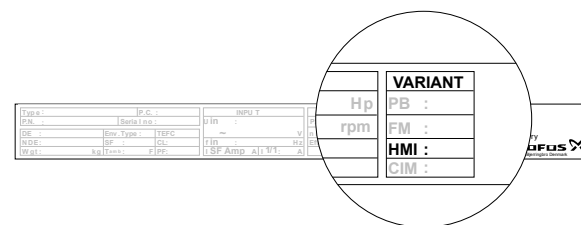

TM064013

#### Model J

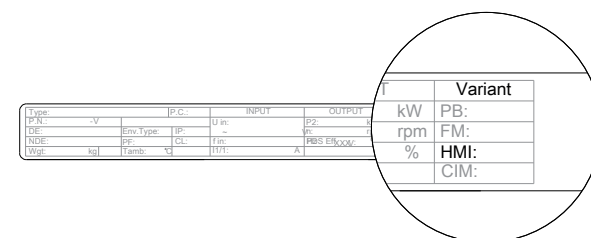

TM082852

#### Model K

#### Operating panel variants

- HMI 200
- HMI 201<sup>2)</sup>

- HMI 300
  - HMI 301
- 2) For motors without a radio module.

## 2.7 Cybersecurity



The product must only be connected to protected network subnets with strict access control.

According to the standard EN 18031-1:2024, the RJ45 connector used for connecting to IP networks is considered an exposed network interface, along with the GENIbus TCP protocol used on it, which is considered an exposed service.

### 2.7.1 Network interfaces and services

In the factory default state, the product exposes the following network interfaces:

Interface	Description
RJ45	Wired Ethernet / IP connectivity

The following services are exposed by the product over its network interfaces in the factory default state.

Interface	Service	Description
RJ45	GENIpro TCP	It is used for connecting the product to a service tool on an engineering workstation. Pairing is required before communication can take place. The GENIpro TCP pairing state is persistent.

## 2.8 Radio modules

### 2.8.1 GLoWpan

#### CAUTION

##### Radiation

Minor or moderate personal injury



- Locate the product at a minimum distance of 8 inches (20 cm) from any body parts. Human tissue may be heated by RF energy.



Installers and end users must be provided with these installation and operating instructions and operating conditions for satisfying RF exposure compliance.

The product incorporates a class 1 radio module for remote control. You can use the module anywhere in the EU without restrictions.

For installation in the USA and Canada, see the appendix.

Via the built-in radio module, the product can communicate with other MLE motors.



The product contains a class 1 radio. Grundfos will support the product with security updates for at least 2 years from production of the unit.

### GLoWpan information

Frequency of operation	2405-2480 MHz
Modulation type	GP O-QPSK
Data rate	1 Mbps
Transmit power	5 dBm EIRP with internal antenna

### 2.8.2 Bluetooth

The product incorporates a Bluetooth (BLE) module for remote control. You can use the module anywhere in the EU without restrictions.

For installation in the USA and Canada, see the appendix.

Via the built-in Bluetooth module, the product can communicate with Grundfos GO.



The product contains a Bluetooth (BLE) module. Grundfos will support the product with security updates for at least 2 years from production of the unit.

#### Bluetooth information

Frequency of operation	2400 - 2483.5 MHz
Modulation type	GFSK
Data rate	2 Mbps
Transmit power	5 dBm EIRP with internal antenna

### 2.9 Battery

A Li-ion battery is fitted in the FM310 and FM311 functional modules.

The Li-ion battery complies with the Battery Directive (2006/66/EC). The battery does not contain mercury, lead or cadmium.

#### WARNING

##### Intoxication or risk of chemical burn

Death or serious personal injury



- The battery can cause severe or fatal injuries in 2 hours or less if it is swallowed or placed inside any part of the body. In such an event, seek medical attention immediately.



- The replacement or servicing of batteries must be carried out by a qualified person.
- The battery contained within this product, whether new or used, is hazardous and is to be kept away from children.

## 3. Receiving the product

### 3.1 Transporting the product

#### WARNING

##### Falling objects

Death or serious personal injury



- Secure the product during transport to prevent it from tilting or falling down.
- When moving the pallets by forklift, only transport one pallet at a time to prevent the load from falling down.
- When storing the product, do not stack more than two pallets on top of each other.

#### WARNING

##### Back injury

Death or serious personal injury



- Use lifting equipment and follow local regulations when lifting the product.

#### CAUTION

##### Crushing of feet

Minor or moderate personal injury



- Wear safety shoes when moving the product.

#### CAUTION

##### Cutting and crushing of hands

Minor or moderate personal injury



- Wear protective gloves when handling pallets.

### 3.2 Inspecting the product

Before installing the product, do the following:

1. Check that the product is as ordered.  
If the product is not as ordered, contact the supplier.
2. Check that no visible parts have been damaged.  
If any visible parts have been damaged, contact the transport company.

## 4. Mechanical installation



Installation related work on the product must only be performed by qualified persons.

### WARNING

#### Rotating parts

Death or serious personal injury



- Stay clear of the product after switching on power, as the shaft can rotate immediately.
- Make sure to install a protective cover before powering on the product.

### WARNING

#### Flying object

Death or serious personal injury



- If no pump or coupling is attached to the motor, always remove the parallel key from the motor shaft before starting the motor.

### WARNING

#### Crushing of feet

Death or serious personal injury



- Secure the product to a solid foundation by bolts through the holes in the flange or the foot.

### WARNING

#### Tilting object

Death or serious personal injury



- Keep your distance when lifting the motor, as the motor may tilt slightly to the sides.

### CAUTION

#### Sharp element

Minor or moderate personal injury



- When opening the packaging or mounting the product on a pump, wear protective gloves to avoid cutting your hands on sharp edges.



The product must be installed in a location with access control to prevent unauthorized access to the product.



To maintain the cURus mark, additional requirements apply to the equipment.

### 4.1 Handling the product

- Observe local regulations concerning limits for manual lifting or handling. The weight of the motor is stated on the nameplate.

### WARNING

#### Fire hazard

Death or serious personal injury



- Make sure that the air inlets are kept clean and free of residuals.

### WARNING

#### Cutting of hands

Death or serious personal injury



- Do not start up and run the motor if there is no pump connected to it or if the fan cover is not installed.

### CAUTION

#### Back injury

Minor or moderate personal injury



- Use lifting equipment and follow local regulations when lifting the product.

### CAUTION

#### Crushing of feet

Minor or moderate personal injury



- Wear safety shoes.
- When lifting the motor, attach lifting equipment to the eye bolts fitted to the motor.
- **Model K:** When lifting the terminal box, attach lifting equipment to the eye bolts or lifting brackets fitted to the terminal box.

### CAUTION

#### Cold surface

Minor or moderate personal injury



- Make sure that no one can accidentally come into contact with cold surfaces. Wear protective gloves.

### CAUTION

#### Hot surface

Minor or moderate personal injury



- Do not touch the product while it is running.



Do not lift the product by the terminal box.

### 4.2 Mounting the motor

For detailed mounting instructions of the motor on pumps, please refer to the pump manuals for guidance on the individual pump types.

### 4.3 Cable entries

The cable entries are fitted with blanking plugs from the factory. See the cable entry sizes in the section on other technical data.

### 4.4 Cable glands

See the list of cable gland sizes in relation to motor sizes in the section on other technical data.

It is recommended to use a cable gland M20 or M40 as applicable with IP 66 rating and suitable for cable strain relief.



After installation, all M20 openings must be closed by means of the delivered blind plugs to maintain the IP 55/66 rating.

### 4.5 Product installation

The drive need to be installed to the pump in either of the following two position:

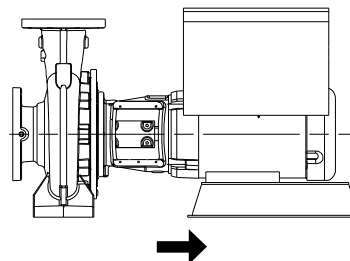

Horizontal orientation, example for VLSE and NBE/NBGE/NKE/NBSE pump



Vertical orientation, example for VLSE pump

TM086647

#### 4.6 Cooling the motor

- Install the motor allowing a distance of minimum 50 mm between the end of the fan cover and the wall or another fixed object.

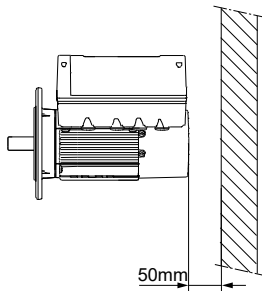

TM084297

- Position the product with sufficient space around.
- Make sure that the temperature of the cooling air does not exceed 50 °C.
- Keep cooling fins and fan blades clean.

#### 4.7 Installing the product in areas with high humidity

##### WARNING

###### Fire hazard

Death or serious personal injury



- In high humidity environments where condensation can occur, connect the product permanently to the power supply and activate the standstill heating function.



To maintain the cURus mark, additional requirements apply to the equipment. See the appendix concerning installation in the USA and Canada.



Do not expose the product to UV radiation.



To avoid condensation, the drive must be continuously energized due to the application of heat, with interruptions such that cooling to the point of condensation does not occur.

- Open the drain holes in the product.



When you open the drain hole, the enclosure class of the motor is lower than standard.

- Connect the product permanently to the power supply. In areas with high humidity, activate the built-in standstill heating function.

#### 4.7.1 Drain holes

When the motor is installed in moist surroundings or areas with high humidity, the bottom drain hole must be open. The enclosure class of the motor will then be lower. This helps prevent condensation in the motor as the motor becomes self-venting, and it allows water and humid air to escape.

The motor has a plugged drain hole on the drive side. You can turn the flange 90° to both sides or 180°.

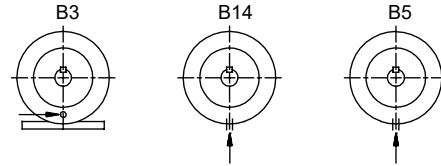

TM029037

Drain holes

#### 4.8 Changing the position of the operating panel

##### WARNING

###### Electric shock

Death or serious personal injury



- Switch off the power supply to the product including the power supply for the signal relays. Wait at least 5 minutes before you make any connections in the terminal box.

You can turn the operating panel 180°. Follow the instructions.

1. Loosen the four screws of the terminal box cover.
2. Remove the terminal box cover.
3. Press and hold in the two locking tabs (A) while gently lifting the plastic cover (B).

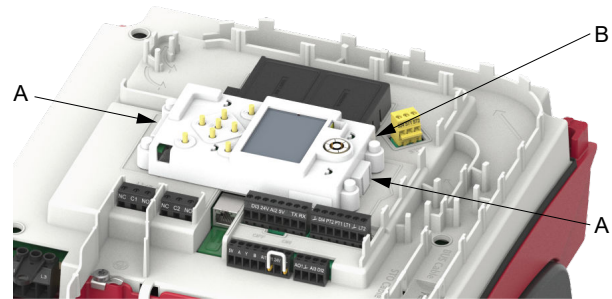

TM087821

Lifting the plastic cover, shown on a Model J motor

4. Turn the plastic cover 180°.



Do not twist the cable more than 90°.

5. Position the plastic cover correctly over the four rubber pins (C). Make sure that the locking tabs (A) are placed correctly.

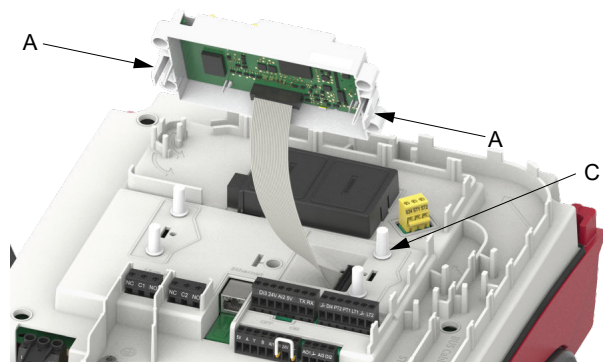

TM087822

Positioning the plastic cover, shown on a Model J motor

6. Tighten the four screws with 3.7 ft-lb (5 Nm).



Make sure that the terminal box cover is aligned with the orientation of the operating panel.

## 5. Electrical connection

### WARNING

#### Electric shock

Death or serious personal injury



- Switch off the power supply to the product including the power supply for the signal relays. Wait at least 5 minutes before you make any connections in the terminal box. Make sure that the power supply cannot be switched on accidentally.
- Check that the supply voltage and frequency correspond to the values stated on the nameplate.

### CAUTION

#### Sharp element

Minor or moderate personal injury



- When installing the wiring in the terminal box, wear protective gloves to avoid cutting your hands on sharp edges.



The user or the installer is responsible for correct earthing and protection according to local regulations.



All electrical connections must be carried out by qualified persons.

### 5.1 Electrical supply systems

#### Power supply network and earthing systems



If you want to supply the product through an IT network, make sure that you have a suitable product variant. If you are in doubt, contact Grundfos.

The internal EMC filter remains connected, and subsequently no reduced leakage current variant is available.

#### Supply line types

##### Model H, I:

The product is not suitable for use on corner earthed grids in installations more than 6560 ft (2000 m) above sea level.

##### Model J:

The product is not suitable for use on corner earthed grids in installations more than 6560 ft (2000 m) above sea level.

##### Model K:

For applications in accordance with IEC 61800-5-1, the maximum voltage to ground must not exceed 277 V.

The product is not suitable for use for corner earthed grids.

Maximum installation altitude: 11480 ft (3500 m).

- TN-S earthing system
- TN-C earthing system
- TN-C-S earthing system
- TT earthing system

### 5.2 Protection against electric shock, indirect contact

#### WARNING

##### Electric shock

Death or serious personal injury



- Connect the product to protective earth and provide protection against indirect contact in accordance with local regulations.

Protective-earth conductors must have a yellow and green (PE) or yellow, green and blue (PEN) colour marking.

### 5.3 Cover for the power cables

Model K is equipped with a cover for the power cables.

The cover is attached to the insulation cover with 2 screws (2) and is equipped with 3 voltage measuring holes (1) for the respective phases (L1, L2, L3).

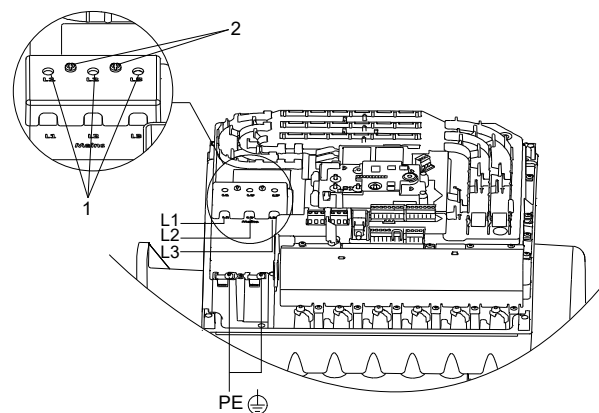

TM084098



The cover for the power cables must be installed before switching on the product.

### 5.4 Protection against mains voltage transients

The product is protected against mains voltage transients in accordance with EN 61800-3.

### 5.5 Motor protection

The product incorporates thermal protection against slow overloading and blocking. No external motor protection is required.

**Model H, I:** The product includes load- and speed- sensitive motor-overload protection.

**Model J:** The product includes load- and speed- sensitive motor-overload protection.

**Model K:** The product includes load- and speed- sensitive motor-overload protection with thermal memory retention.

### 5.6 Connecting an external switch

We recommend that you connect the product to an external switch.

1. Connect the switch via terminals 2 (DI1) and 6 (GND).  
A jumper is added from factory.

2. Enable the **External stop** function.  
Default setting from factory.

## 5.7 Cable requirements

### 5.7.1 Cable cross-section

#### **WARNING**

##### **Electric shock**

Death or serious personal injury

- Switch off the power supply to the product including the power supply for the signal relays. Wait at least 5 minutes before you make any connections in the terminal box.
- Follow the wiring diagrams and local regulations.
- Use branch-circuit protection fuses.
- Comply with local regulations as to cable cross-sections.
- Use the recommended fuse size.
- Connect the cables to terminals by applying the recommended tightening torque.



#### **WARNING**

##### **Fire hazard**

Death or serious personal injury

- Comply with local regulations as to cable cross-sections.
- Use the recommended fuse size.
- Connect the cables to terminals by applying the recommended tightening torque.



Make sure that the cables are secured with cable glands providing strain relief.



Recommended cable type for Model K: H07RN-F.

## 5.7.1.1 Cable cross-section data for MLE motors

## 3 × 440-480 V, 60 Hz, Model J

Speed [rpm]	Power P2 [HP]	Supply voltage [V]	Nominal current [A]	Service factor current [A]	Cable cross-section [AWG]
3500-4000	5	3 × 440-480	6.2 - 5.8	7.2 - 6.7	14
	7 1/2	3 × 440-480	9.1 - 8.5	10.5 - 9.8	14
	10	3 × 440-480	12.4 - 11.5	14.3 - 13.3	12
	15	3 × 440-480	17.9 - 16.6	20.6 - 19.1	10
4000-5900	5	3 × 440-480	6.2 - 5.8	7.2 - 6.7	14
	7 1/2	3 × 440-480	9.4 - 8.6	10.9 - 9.9	14
	10	3 × 440-480	12.5 - 11.6	14.4 - 13.4	12
	15	3 × 440-480	18.2 - 17.0	20.1 - 19.6	10

## 3 × 200-240 V, 60 Hz, Model J

Speed [rpm]	Power P2 [HP]	Supply voltage [V]	Nominal current [A]	Service factor current [A]	Cable cross-section [AWG]
3400-4000	3	3 × 200-240	7.9 - 6.6	9.1 - 7.6	14
	5	3 × 200-240	13.2 - 10.9	15.2 - 12.6	12
	7 1/2	3 × 200-240	20.0 - 16.0	23.0 - 18.4	10

## 3 × 440-480 V, 60 Hz, Model K

Speed [rpm]	Power P2 [HP]	Supply voltage [V]	Nominal current [A]	Service factor current [A]	Cable cross-section [AWG]
3500-4000	20	3 × 440-480	23.1 - 21.8	27.3 - 24.8	8
	25	3 × 440-480	28.5 - 26.4	32.9 - 30.2	8
	30	3 × 440-480	34.3 - 31.6	39.4 - 36.2	8

## 3 × 200-240 V, 60 Hz, Model K

Speed [rpm]	Power P2 [HP]	Supply voltage [V]	Nominal current [A]	Service factor current [A]	Cable cross-section [AWG]
3400-4000	10	3 × 200-240	25.6 - 21.4	29.0 - 24.2	8
	15	3 × 200-240	37.8 - 31.9	41.0 - 34.5	6

5.7.1.2 Conductors

Conductor types

**Model H, I:** Use stranded or solid copper conductors only.

**Model J:** Use stranded or solid copper conductors only.

**Model K:** Use stranded copper conductors only.

Conductor temperature ratings

**Model H, I:** Use minimum 140 °F copper conductors.

**Model J:** Use minimum 140 °F copper conductors.

**Model K:** Use 167 °F copper conductors only. The wire sizes for the mains supply must be sized for a wire size which is suitable for at least 125% of the rated input current of the motor drive units.

5.7.1.3 Conduit hubs

Conduit hubs must be UL listed according to UL Category Code Number (CCN) DWTT/DWTT7 and be suitable for the relevant enclosure type rating in accordance with UL 514B and CSA C22.2 No. 18.3.

For type 12 enclosures, it is also allowed to use type 12 and 13 conduit hubs.

The relevant type rating can be found on the nameplate of the product.

5.7.2 Three-phase connections

The cables in the terminal box must be as short as possible. However, the separated protective-earth conductor must be so long that it is the last one to be disconnected in case the cable is inadvertently pulled out of the cable entry.



To maintain the cURus mark, additional requirements apply to the equipment. See the appendix concerning installation in the USA and Canada.

**Model H, I:** To avoid loose connections, ensure that the terminal block for L1, L2 and L3 is pressed home in its socket when the power cable has been connected.

**Model J:** To avoid loose connections, ensure that the terminal block for L1, L2 and L3 is pressed home in its socket when the power cable has been connected.

**Model K:** To avoid loose connections, ring terminals must be used. Ensure that ring terminals are short enough to stay within the terminal cover.

Check that the supply voltage and frequency correspond to the values stated on the nameplate.

Power supply connection on a three-phase product

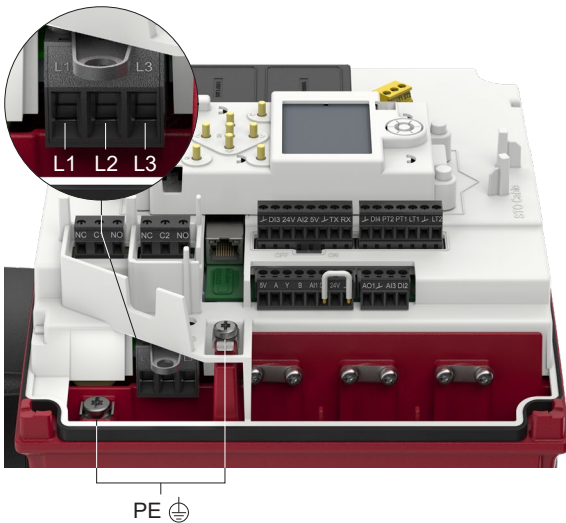

TM088951

Model I

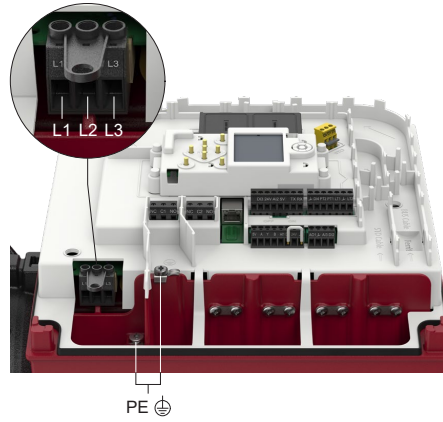

TM088952

Model J

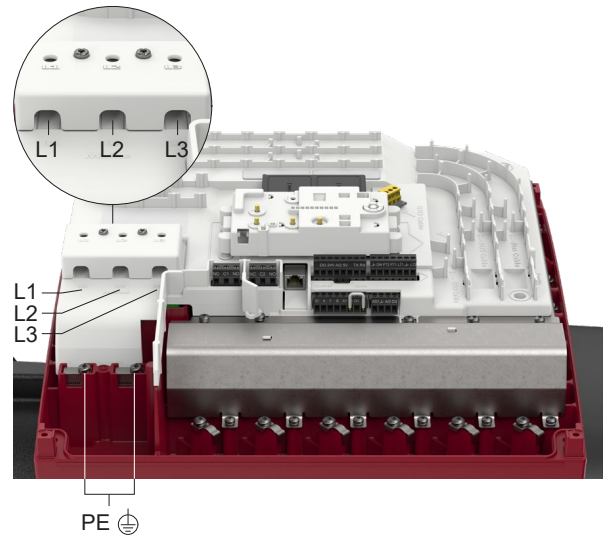

TM089171

Model K

Pos.	Description
L1	Phase 1
L2	Phase 2
L3	Phase 3
PE	Protective earth

## 5.8 Additional protection

### 5.8.1 Residual-current circuit breakers

#### WARNING

##### Electric shock

Death or serious personal injury



- This product can cause a DC current in the protective-earth conductor. If a residual current-operated protective (RCD) or monitoring (RCM) device is used for protection in case of direct or indirect contact, only an RCD or RCM of Type B is allowed on the supply side of this product.

The residual-current circuit breaker must be marked.

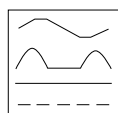

Take into account the total leakage current of all the electrical equipment in the installation.

This product may cause a direct current in the protective-earth conductor.

#### Connection example for three-phase supply

The figure shows an example of a mains-connected three-phase motor with a main switch, a backup fuse and a residual-current circuit breaker, type B.

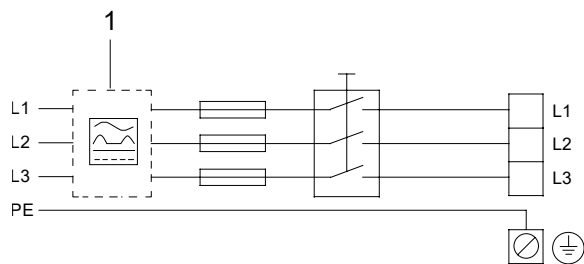

Pos.	Description
1	Residual-current circuit breaker, type B
L1	Phase 1
L2	Phase 2
L3	Phase 3
PE	Protective earth

### 5.8.2 Overvoltage and undervoltage protection

Overvoltage and undervoltage may occur in case of unstable power supply or a faulty installation. The product stops if the voltage falls outside the permissible voltage range. The product restarts automatically when the voltage is within the permissible voltage range. The product requires no additional protection relay.



The product is protected against transients from the power supply according to EN 61800-3. In areas with high lightning intensity, we recommend external lightning protection.

Overvoltage category:

The product is approved for Overvoltage category III rating.

### 5.8.3 Overload protection

The motor-current protection settings are fixed for each motor variants. The settings ensure that the motor is protected against overtemperature in all operating states with regard to supply voltage and shaft load, including a blocked shaft.

The motors are current controlled and will respond by reducing the speed if the shaft load increases more than 10 % of the nominal load.

If the shaft load forces the speed down to minimum speed, the motor shuts down.

A sudden increase in the motor current caused by a fault where the peak of the motor current is increased 60 % above nominal will cause the motor to shut down within 0.5 ms.

The product requires no additional protection.

### 5.8.4 Overtemperature protection

The motor is thermally protected by a temperature measurement in the drive. It can handle the lack of airflow over the motor in case the fan cover is blocked. It also means that the protection has a built-in memory retention.

The time from start to shutdown due to overtemperature is therefore always longer when starting at a motor temperature close to the ambient temperature compared with restarting after a shutdown due to overtemperature.

### 5.8.5 Protection against phase unbalance

Phase unbalance on the power supply must be minimised. The three-phase motor must be connected to a power supply with a quality corresponding to IEC 60146-1-1, class C. This also ensures long life of the components.

### 5.8.6 Short-circuit current

The product's electronic power output short-circuit protection circuitry meets the requirements of IEC 60364-4-41:2005/AMD1:-, Clause 411.

**Model H, I:** If a short circuit occurs, the pump can be used on a power supply delivering not more than 5000 RMS symmetrical amperes, 600 V maximum.

**Model J:** If a short circuit occurs, the pump can be used on a power supply delivering not more than 5000 RMS symmetrical amperes, 600 V maximum.

**Model K:** Suitable for use on a circuit capable of delivering not more than 5000 rms symmetrical amperes, when protected by gG fuses. See the section on fuse sizes.

### 5.8.7 Functional modules

The functional modules are different types of add-on boards containing various types of input and output terminals for the user to connect different types of sensors, for example switches and relays.

The product can only contain one functional module at the time.

The selection of module depends on the application and the required number of inputs and outputs.

#### Cable connections

The screen of signal cables and bus connection cables must be connected to ground via one of the earth clamps (H).

See the section on signal cables and bus connection cables.

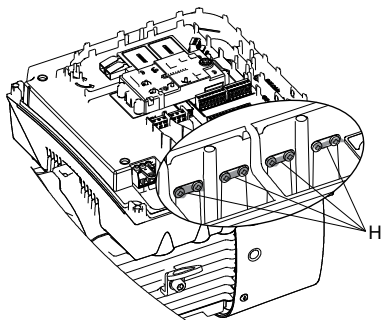

TM084041

Model J

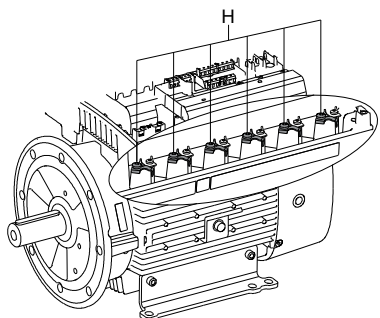

TM082868

Model K

**5.8.7.1 Functional module, FM300**

**Inputs and outputs**

The module has these connections:

- three analog inputs
- one analog output
- two dedicated digital inputs
- two configurable digital inputs or open-collector outputs
- Grundfos Digital Sensor input and output
- two Pt100/1000 inputs
- LiqTec sensor inputs
- two signal relay outputs
- GENIbus connection.

The inputs and outputs are internally separated from the power supply-conducting parts by reinforced insulation and galvanically separated from other circuits. All control terminals are supplied with protective extra-low voltage (PELV), ensuring protection against electric shock.

**Signal relay 1**

LIVE: You can connect supply voltages up to 250 VAC to the output.

PELV: The output is galvanically separated from other circuits. Therefore, you can connect the supply voltage or protective extra-low voltage to the output as desired.

**Signal relay 2**

PELV: The output is galvanically separated from other circuits. Therefore, you can connect the supply voltage or protective extra-low voltage to the output as desired.

**Connection terminals for the power supply**

Phases	Terminals
Single-phase	N, PE, L
Three-phase	L1, L2, L3, PE

**Connection terminals for inputs and outputs**

**DANGER**

**Electric shock**

Death or serious personal injury



- Make sure that the wires to be connected to the connection groups below are separated from each other by reinforced insulation in their entire lengths.

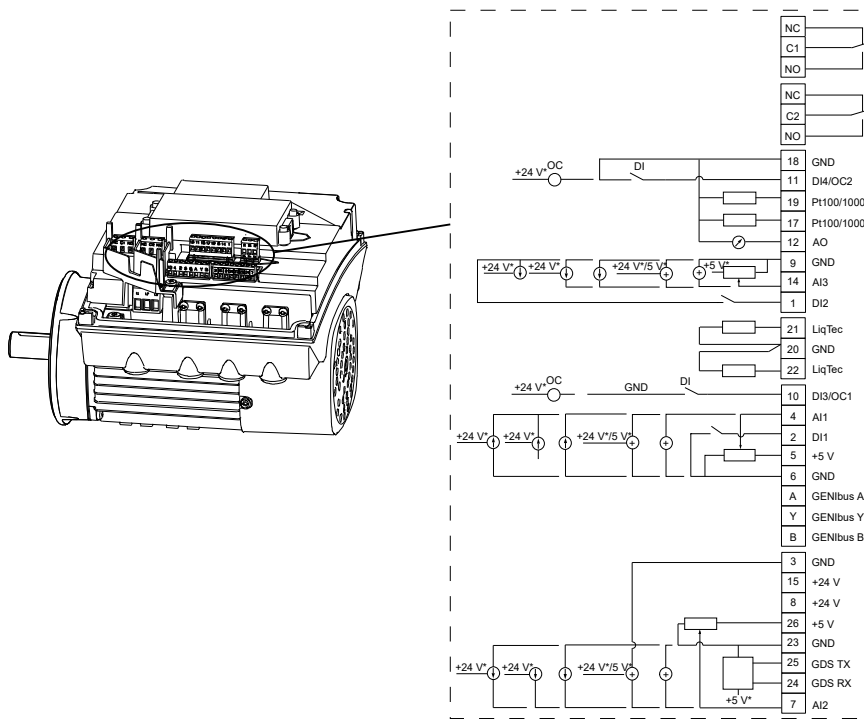

TM053509

Terminal	Type	Function
NC	Normally closed contact	
C1	Common	Signal relay 1. LIVE or PELV.
NO	Normally open contact	
NC	Normally closed contact	
C2	Common	Signal relay 2. PELV only.
NO	Normally open contact	
18	GND	Protective earth.
11	DI4/OC2	Digital input/output, configurable. Open collector: Maximum 24 V resistive or inductive.
19	Pt100/1000 input 2	Pt100/1000 sensor input
17	Pt100/1000 input 1	Pt100/1000 sensor input

Terminal	Type	Function
12	AO	Analog output: 0-20 mA or 4-20 mA 0-10 V.
9	GND	Protective earth.
14	AI3	Analog input: 0-20 mA or 4-20 mA. 0.5 - 3.5 V, 0-5 V or 0-10 V.
1	DI2	Digital input, configurable.
21	LiqTec sensor input 1	LiqTec sensor input. White conductor.
20	GND	Protective earth. Brown and black conductors.
22	LiqTec sensor input 2	LiqTec sensor input. Blue conductor.
10	DI3/OC1	Digital input/output, configurable. Open collector: Maximum 24 V resistive or inductive.
4	AI1	Analog input: 0-20 mA or 4-20 mA. 0.5 - 3.5 V, 0-5 V or 0-10 V.
2	DI1	Digital input, configurable.  Digital input 1 is factory-set to be start or stop input where an open circuit results in stop. A jumper has been factory-fitted between terminals 2 and 6. Remove the jumper if digital input 1 is to be used as external start or stop or any other external function.
5	+5 V	Power supply to a potentiometer or sensor.
6	GND	Protective earth.
A	GENIbus, A	GENIbus, A (+).
Y	GENIbus, Y	GENIbus, Y (GND).
B	GENIbus, B	GENIbus, B (-).
3	GND	Protective earth.
15	+24 V	Power supply.
8	+24 V	Power supply.
26	+5 V	Power supply to a potentiometer or sensor.
23	GND	Protective earth.
25	GDS TX	Grundfos Digital Sensor output.
24	GDS RX	Grundfos Digital Sensor input.
7	AI2	Analog input: 0-20 mA or 4-20 mA. 0.5 - 3.5 V, 0-5 V or 0-10 V.

### 5.8.7.2 Functional module, FM310 and FM311 from 15 kW 2-pole and 11 kW 4-pole

#### Inputs and outputs



The FM311 functional module does not include Bluetooth connection.

The module has these connections:

- three analog inputs, VLSE with factory fitted differential pressure sensor is connected to one of these analog inputs.
- one analog output
- two dedicated digital inputs
- two configurable digital inputs or open-collector outputs
- Input and output for Grundfos Digital Sensor Not applicable for NBE, NBGE, NKE, NBSE and VLSE pumps. The factory-fitted differential-pressure sensor for NBE, NBGE, NKE, NBSE Series 2000 is connected to this input.
- Grundfos Digital Sensor input and output
- two Pt100/1000 inputs

#### Connection terminals for inputs and outputs

### WARNING



#### Electric shock

Death or serious personal injury

- Make sure that the wires to be connected to the connection relays below are separated from each other by reinforced insulation in their entire lengths.

The inputs and outputs are internally separated from the mains-conducting parts by reinforced insulation and galvanically separated from other circuits. All control terminals are supplied with safety extra-low voltage (SELV), ensuring protection against electric shock.

Cables for the relays and the Ethernet cable must be rated at least 250 V/2 A.

The Ethernet cable must be rated at least Cat5e/Cat6 with screening.



The 250V contacts of the alarm relay (NC/C1/NO) on the functional modules FM310 and FM311 must not be connected directly to the supply mains, but energized by an isolated power supply or transformer with galvanic isolation.

- two LiqTec sensor inputs
  - two signal relay outputs
  - GENIbus/Modbus connection
  - two Safe Torque Off (STO) inputs
  - Ethernet connection
  - Bluetooth (BLE) connection. <sup>3)</sup>
- <sup>3)</sup> FM311 is without Bluetooth.

#### Signal relay 1

LIVE: You can connect supply voltages up to 250 VAC to the output.

SELV: The output is galvanically separated from other circuits.

Therefore, you can connect the supply voltage or safety extra-low voltage to the output as desired.

#### Signal relay 2

SELV: The output is galvanically separated from other circuits.

Therefore, you can connect the supply voltage or safety extra-low voltage to the output as desired.

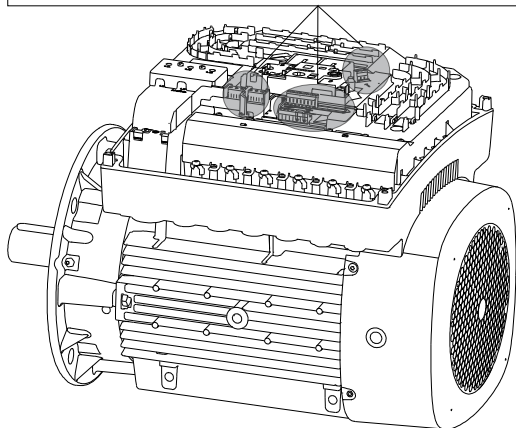
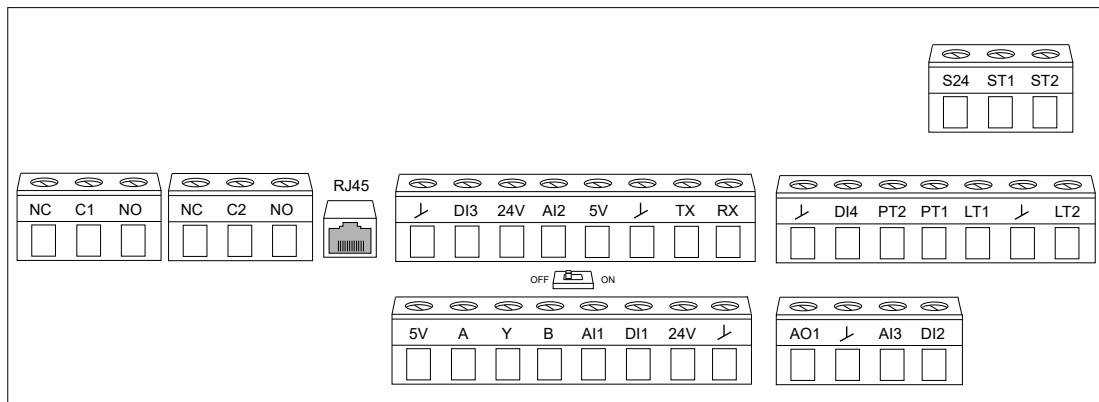

TM082862

Terminal	Type	Function
NC	Normally closed contact	
C1	Common	Signal relay 1: LIVE or SELV
NO	Normally open contact	
NC	Normally closed contact	
C2	Common	Signal relay 2: SELV only
NO	Normally open contact	
RJ45	Ethernet	Ethernet communication
GND	GND	Signal ground
DI3	DI3/OC1	Digital input/output, configurable Open collector: Maximum 24 V resistive or inductive
24V	+24 V	Power supply
AI2	AI2	Analog input: • 0-20 mA or 4-20 mA • 0.5 - 3.5 V, 0-5 V or 0-10 V.
5V	+5 V	Power supply to a potentiometer or sensor
GND	GND	Signal ground
TX	GDS TX	Grundfos Digital Sensor output
RX	GDS RX	Grundfos Digital Sensor input
GND	GND	Signal ground
DI4	DI4/OC2	Digital input/output, configurable Open collector: Maximum 24 V resistive or inductive
PT2	Pt100/1000 input 2	Pt100/1000 sensor input 2
PT1	Pt100/1000 input 1	Pt100/1000 sensor input 1
LT1	LiqTec sensor input 1	LiqTec sensor input 1 White conductor

Terminal	Type	Function
GND	GND	Signal ground Brown and black conductors
LT2	LiqTec sensor input 2	LiqTec sensor input 2 Blue conductor
5V	+5 V	Power supply to a potentiometer or sensor
A	GENIbus, A	GENIbus, A (+) / Modbus, D1 (+)
Y	GENIbus, Y	GENIbus, GND / Modbus, GND
B	GENIbus, B	GENIbus, B (-) / Modbus, D0 (-)
AI1	AI1	Analog input: <ul style="list-style-type: none"> <li>0-20 mA or 4-20 mA</li> <li>0.5 - 3.5 V, 0-5 V or 0-10 V.</li> </ul>
DI1	DI1	Digital input, configurable  Digital input 1 is factory-set to be start or stop input where an open circuit results in stop. A jumper has been factory-fitted between terminals DI1 and GND. Remove the jumper if digital input 1 is to be used as external start or stop or any other external function.
24V	+24 V	Power supply
GND	GND	Signal ground
AO1	AO	Analog output: <ul style="list-style-type: none"> <li>0-20 mA or 4-20 mA</li> <li>0-10 V.</li> </ul>
GND	GND	Signal ground
AI3	AI3	Analog input: <ul style="list-style-type: none"> <li>0-20 mA or 4-20 mA</li> <li>0.5 - 3.5 V, 0-5 V or 0-10 V.</li> </ul>
DI2	DI2	Digital input, configurable
S24	+24 V (STO)	Power supply to the Safe Torque Off inputs
ST1	STO1	Safe Torque Off - Input 1
ST2	STO2	Safe Torque Off - Input 2

**5.8.8 Signal relays**

The functions of the two signal relays are shown in the table below.

The motor has two outputs for potential-free signals via two internal relays. You can set the signal outputs to **Operation**, **Pump running**, **Ready**, **Alarm** and **Warning**.

**Grundfos Eye is off**

The power is off.

Operation	Pump running	Ready	Alarm	Warning	Operating mode
					-

**Grundfos Eye is rotating green**

The pump runs in **Normal** mode in open or closed loop.

Operation	Pump running	Ready	Alarm	Warning	Operating mode
					<b>Normal</b> <b>Min.</b> or <b>Max.</b>

**Grundfos Eye is rotating green**

The pump runs in **Manual** mode.

Operation	Pump running	Ready	Alarm	Warning	Operating mode
					<b>Manual</b>

**Grundfos Eye is permanently green**

The pump is ready for operation but is not running.

Operation	Pump running	Ready	Alarm	Warning	Operating mode
					<b>Stop</b>

**Grundfos Eye is rotating yellow**

There is a warning, but the pump is running.

Operation	Pump running	Ready	Alarm	Warning	Operating mode
					<b>Normal</b> <b>Min.</b> or <b>Max.</b>

**Grundfos Eye is rotating yellow**

There is a warning, but the pump is running.

Operation	Pump running	Ready	Alarm	Warning	Operating mode
					<b>Manual</b>

**Grundfos Eye is permanently yellow**

There is a warning, and the pump is stopped via a **Stop** command.

Operation	Pump running	Ready	Alarm	Warning	Operating mode
					<b>Stop</b>

**Grundfos Eye is rotating red**

There is an alarm, but the pump is running.

Operation	Pump running	Ready	Alarm	Warning	Operating mode
					<b>Normal Min. or Max.</b>

**Grundfos Eye is rotating red**

There is an alarm, but the pump is running.

Operation	Pump running	Ready	Alarm	Warning	Operating mode
					<b>Manual</b>

**Grundfos Eye is flashing red**

The pump is stopped due to an alarm.

Operation	Pump running	Ready	Alarm	Warning	Operating mode
					<b>Stop</b>

### 5.8.9 Signal cables

Use screened cables with a cross-sectional area of minimum 28 AWG (0.5 mm<sup>2</sup>) and maximum 16 AWG (1.5 mm<sup>2</sup>) for the external on/off switch, digital inputs, setpoint and sensor signals.

The wires in the motor terminal box must be as short as possible.

#### 5.8.9.1 Connecting signal cables

1. Connect the screens of the cables to the frame at both ends with good connection. The screens must be as close as possible to the terminals.

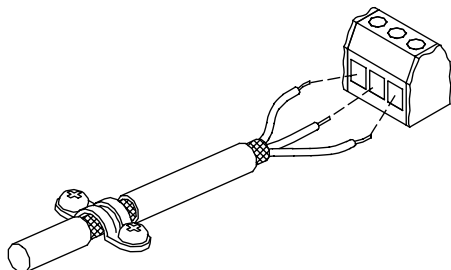

Model J

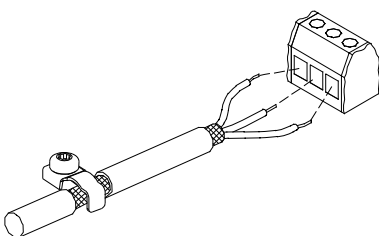

Model K

2. Connect the signal cables to the terminals.
3. Depending on the model, tighten one or two earth clamp screws.  
See the section on functional modules.

### 5.8.10 Bus connection cable

#### 5.8.10.1 Connecting a 3-core bus cable, GENibus

For the bus connection, use a screened 3-core cable with a cross-sectional area of minimum 28 AWG (0.5 mm<sup>2</sup>) and maximum 16 AWG (1.5 mm<sup>2</sup>).

- If the motor is connected to a unit with a cable clamp identical to the one on the product, connect the screen to the cable clamp.
- If the unit has no cable clamp, leave the screen unconnected at this end.

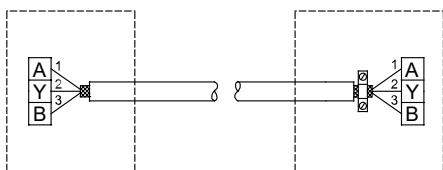

#### 5.8.10.2 Connecting a 3-core bus cable, Modbus

A screened, twisted-pair cable must be used. The cable screen must be connected to protective earth at both ends.

#### Recommended connection

Terminal	Modbus	Colour code	Data signal
A	D1	Yellow	Positive
B	D0	Brown	Negative
Y	Common/GND	Grey	Common/GND

### Fitting the cable

1. Connect the yellow conductor to terminals D1 and A.
2. Connect the brown conductor to terminals D0 and B.
3. Connect the grey conductor to terminals Common/GND and Y.
4. Connect the cable screens to protective earth via the earth clamp.

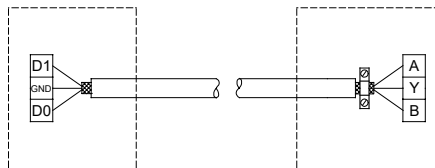

It is important to connect the screen to protective earth through the earth clamp and to connect the screen to protective earth in all units connected to the bus line.

#### 5.8.10.3 Connecting a 2-core bus cable

- Connect a screened 2-core bus cable as follows:

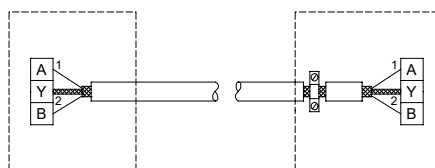

#### 5.8.10.4 Connecting an Ethernet cable

For the USA and Canada, the connection of Ethernet cables must be done by connecting the Ethernet cable screen to an earth clamp on the terminal box, as shown below.

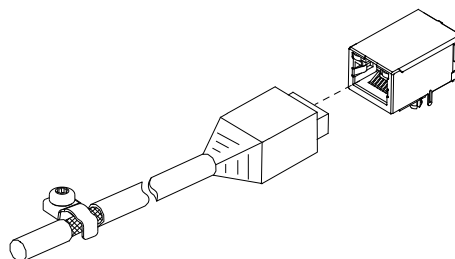

#### Connecting an Ethernet cable

The Ethernet cable must be rated at least Cat5e/Cat6 with screening.

The recommended Ethernet cable types for earth clamp applications are SF/UTP, S/FTP or SF/FTP, where the cable screen consists of both a braided and a foil screen.

#### 5.8.10.5 Bus signal

The product enables serial communication via an RS-485 input. The communication is carried out according to the Grundfos GENibus protocol and enables connection to a building management system or another external control system.

Via a bus signal, you can remote-set operating parameters, such as setpoint and operating mode. At the same time, the product can provide status information about important parameters, such as the actual value of the control parameter, input power and fault indications, via the bus.

Contact Grundfos for further information.



If you use a bus signal, the local settings made via Grundfos GO or the HMI 300 or 301 operating panel will be overruled. In case the bus signal fails, the product will run with the local settings made via Grundfos GO or the HMI 300 or 301 operating panel.

TM083382

TM021325

TM082967

TM070221

TM070223

TM085827

5.8.11 Installing a communication interface module

**WARNING**

**Electric shock**

Death or serious personal injury



- Switch off the power supply to the product including the power supply for the signal relays. Wait at least 5 minutes before you make any connections in the terminal box. Make sure that the power supply cannot be switched on accidentally.



Always use an antistatic service kit when handling electronic components. This prevents static electricity from damaging components.

When unprotected, the component must be placed on the antistatic cloth.



Antistatic service kit

1. Disconnect the power supply.
2. Remove the terminal box cover.
3. Remove the plug connection for the CIM module.
4. Remove the cover of the CIM module by pressing the locking tab (A) and lifting the end of the cover (B). Then lift the cover off the hooks (C).

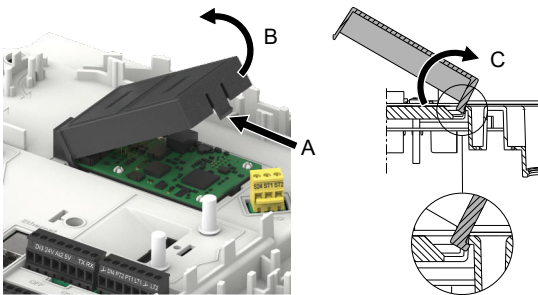

5. Remove the screw connecting the frame connection of the CIM module to the functional module.
6. Insert a screwdriver at the three plastic holders and loosen the CIM module from the isolation cover.

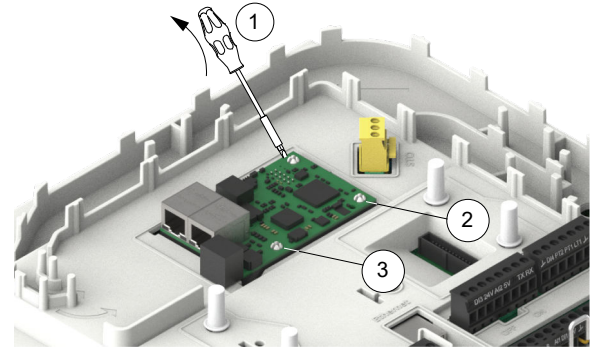

TM087824

7. Gently lift the CIM module away from the isolation cover so that the connecting plug is not damaged.
8. Fit the new CIM module by aligning it with the plastic holders and the connecting plug. Press home the module using your fingers.

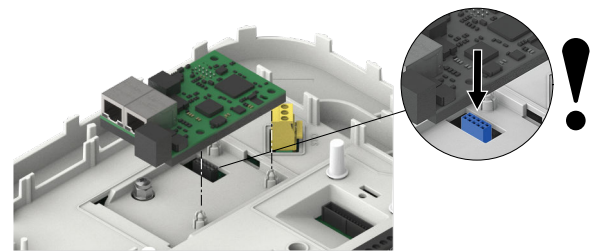

TM087825

9. Fit the frame screw in the CIM module.
10. Fit the cover by leading the slits into the end with the plug connection and clicking the locking tabs onto the isolation cover.
11. Press down the module using your fingers. Check that the plug has been pressed home.
12. If the module is supplied with an FCC label, fix the label on the terminal box.



TM087826

13. Fit the terminal box cover.

## 6. Control functions

### 6.1 User interfaces

#### **WARNING**



##### **Hot surface**

Death or serious personal injury

- Touch only the buttons on the operating panel. The product may be very hot.

#### **WARNING**



##### **Electric shock**

Death or serious personal injury

- If the operating panel is cracked or perforated, replace it immediately. Contact the nearest Grundfos sales company.

You can change the settings by means of the following user interfaces:

- HMI 200 operating panel
- HMI 201 operating panel<sup>4)</sup>
- HMI 300 operating panel
- HMI 301 operating panel<sup>4)</sup>
- Grundfos GO application.

<sup>4)</sup> HMI without a radio module.

All settings are saved if the power supply is switched off.

### 6.1.1 Operating panels, HMI 200 and 201

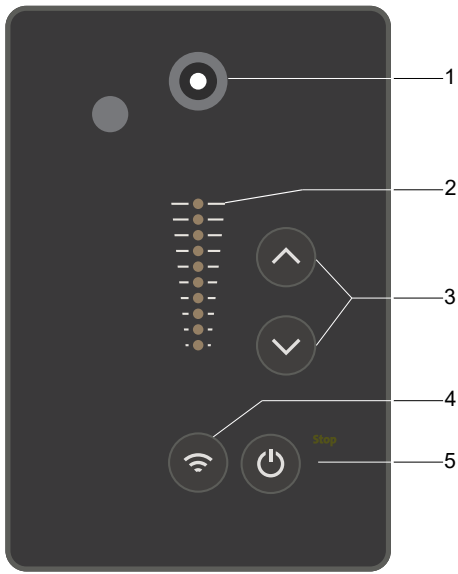

TM082873

Pos.	Symbol	Description
1		<b>Grundfos Eye:</b> The indicator light shows the operating status of the product.
2	-	Light fields for indication of the setpoint.
3		<b>Up/Down:</b> The buttons change the setpoint.
4		<b>Communication:</b> The button enables communication with Grundfos GO and other products of the same type.
5		<b>Start/Stop:</b> Press the button to make the product ready for operation or to start and stop the product. <b>Start:</b> If you press the button when the product is stopped, the product starts if no other functions with higher priority have been enabled. <b>Stop:</b> If you press the button when the product is running, the product always stops. When you press the button, the stop icon appears at the bottom of the display.

#### 6.1.1.1 Setting the setpoint in constant parameter mode

The following applies for motors set to operate in **Const. other val.** Set the desired setpoint by pressing the **Up** or **Down** buttons.

The green light fields on the operating panel indicate the setpoint set.

The following example applies to a pump or motor in an application where a pressure sensor gives a feedback to the pump or motor. The sensor has been set manually, and the pump or motor does not automatically register a connected sensor.

Light fields 5 and 6 are activated, indicating a desired setpoint of 116 psi (8 bar) with a sensor measuring range from 0 to 232 psi (16 bar). The setting range is equal to the sensor measuring range.

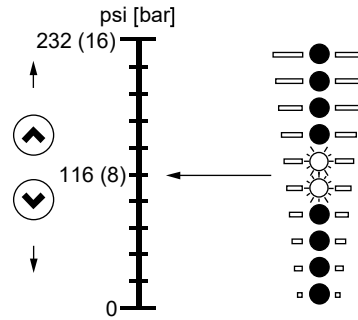

TM068914

#### 6.1.1.2 Setting the setpoint in constant curve mode

Set the desired setpoint by pressing the **Up** or **Down** buttons.

The green light fields on the operating panel indicate the setpoint set.

**Example:** In **Constant curve** mode, the motor output is between minimum and maximum speed defined by **Operating range**.

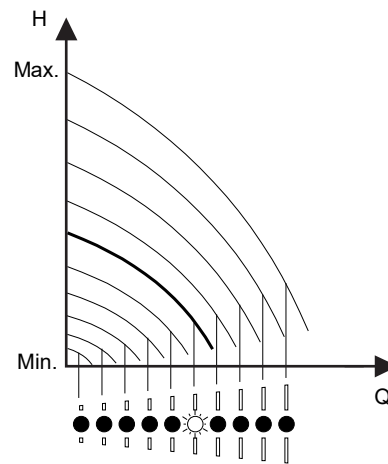

TM054895

### 6.1.1.3 Setting to maximum speed

The motor must not be in operating mode **Stop**.

- Press and hold the **Up** button until the top light field is on and starts flashing.

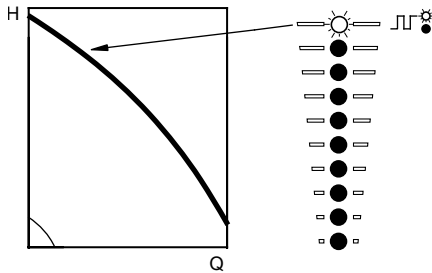

TM054896

### 6.1.1.4 Setting to minimum speed

The motor must not be in operating mode **Stop**.

- Press and hold the **Down** button until the bottom light field is on and starts flashing.

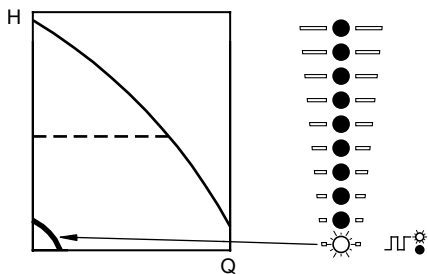

TM054897

### 6.1.1.5 Starting the pump

How you start the pump depends on how it was stopped. Start the pump in one of the following ways:

- If the pump was stopped by pressing the **Start/Stop** button, start the pump by pressing the **Start/Stop** button.
- If the pump was stopped by pressing and holding the **Down** button, start the pump by pressing and holding the **Up** button.

### 6.1.1.6 Stopping the pump

- Stop the pump in one of the following ways:
  - Press the **Start/Stop** button.
  - Press and hold the **Down** button until all light fields are off.
  - Use Grundfos GO.
  - Use a digital input set to **External stop**.

### 6.1.1.7 Resetting alarms and warnings in products with the HMI 200 or HMI 201 operating panel

- You can reset a fault indication in one of the following ways:
  - Briefly press the **Up** or **Down** button. This is not possible if the buttons have been locked. This does not change the setting of the motor.
  - Switch off the power supply until the indicator lights are off.
  - Switch the external start and stop input off, and then on again.
  - Use Grundfos GO.
  - Use the digital input if you have set it to **Alarm resetting**.

### 6.1.2 Operating panels, HMI 300 and 301

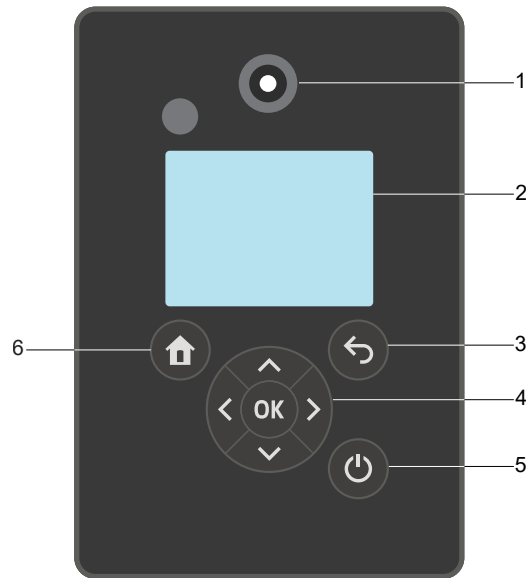

TM082874

Pos.	Symbol	Description
1		<b>Grundfos Eye:</b> The indicator light shows the operating status of the product.
2	-	Graphical colour display.
3		<b>Back:</b> Press the button to go one step back.
		<b>Left/Right:</b> Press the buttons to navigate between main menus, displays and digits. When you change the menu, the display shows the top display of the new menu.
		<b>Up/Down:</b> Press the buttons to navigate between submenus or change the value settings. If you have disabled the possibility to make settings with the <b>Enable/disable settings</b> function, you can enable it again temporarily by pressing these buttons simultaneously for at least 5 seconds.
4		<b>OK:</b> Press the button to do as follows: <ul style="list-style-type: none"> <li>save changed values, reset alarms and expand the value field</li> <li>enable communication with Grundfos GO and other products of the same type.</li> </ul> When you try to establish radio communication between the product and Grundfos GO or another product, the green indicator light in Grundfos Eye flashes. In the controller display, a note states that a device wants to connect to the product. Press <b>OK</b> on the product operating panel to allow communication with Grundfos GO or Grundfos GO Link and other products of the same type.
5		<b>Start/Stop:</b> Press the button to make the product ready for operation or to start and stop the product. <b>Start:</b> If you press the button when the product is stopped, the product starts if no other functions with higher priority have been enabled. <b>Stop:</b> If you press the button when the product is running, the product always stops. When you press the button, the stop icon appears at the bottom of the display.
6		<b>Home:</b> Press the button to go to the <b>Home</b> menu.

### 6.1.2.1 Home display

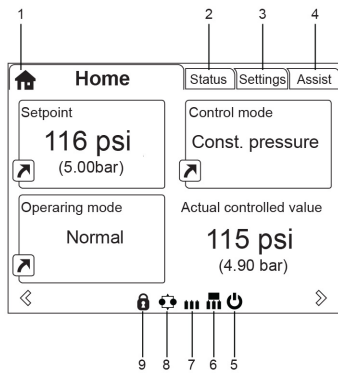

TM068915

Pos.	Symbol	Description
4	-	<b>Assist:</b> This menu enables assisted setup, provides a short description of the control modes and offers fault-finding advice.
5		<b>Start/Stop:</b> The icon indicates that the product was stopped with the <b>Start/Stop</b> button.
6		<b>Master:</b> The icon indicates that the product is functioning as the master in a multipump system.
7		<b>Slave:</b> The icon indicates that the product is functioning as a slave in a multipump system.
8		<b>Multioperation:</b> The icon indicates that the product is operating in a multipump system.
9		<b>Lock:</b> The icon indicates that the possibility to make settings has been disabled for protective reasons.

Pos.	Symbol	Description
1		<b>Home:</b> This menu shows up to four user-defined parameters. You can access each parameter directly from this menu.
2	-	<b>Status:</b> This menu shows the status of the product and system, warnings and alarms.
3	-	<b>Settings:</b> This menu gives access to all setting parameters. The menu also allows you to make detailed settings.

### 6.1.2.2 Startup guide

The function is only available in the HMI 300 and HMI 301 operating panels.

The startup guide starts at the first startup and guides you through the settings needed for the product to operate in the given application. When the startup guide has been completed, the main menus appear in the display.

You can always run the startup guide at a later time.

## 6.1.2.3 Menu overview for the HMI 300 and 301 operating panels

	NBE, NBGE, NKE, NBSE, VLSE	NBE, NBGE, NKE, NBSE Series 2000; VLSE with Delta $\rho$ sensor	Multipump system
Home	•	•	•
<hr/>			
Status	NBE, NBGE, NKE, NBSE, VLSE	NBE, NBGE, NKE, NBSE Series 2000; VLSE with Delta $\rho$ sensor	Multipump system
Operating status	•	•	•
Operating mode, from	•	•	•
Control mode	•	•	•
Pump performance	•	•	•
Actual control. value	•	•	•
Resulting setpoint	•	•	•
Liquid temp.	•	•	•
Speed	•	•	•
Acc. flow and specific energy	•	•	•
Power and energy consumption	•	•	•
Measured values	•	•	•
Analog input 1	•	•	•
Analog input 2	•	•	•
Analog input 3	•	•	•
Pt100/1000 input 1	•	•	•
Pt100/1000 input 2	•	•	•
Analog output	•	•	•
Warning and alarm	•	•	•
Actual warning or alarm	•	•	•
Warning log	•	•	•
Alarm log	•	•	•
Operating log	•	•	•
Operating hours	•	•	•
Fitted modules	•	•	•
Date and time	•	•	•
Product identification	•	•	•
Motor bearing monitoring	•	•	•
Multi-pump system			•
System operating status			•
System performance			•
System input power and energy			•
Pump 1, multi-pump system			•
Pump 2, multi-pump system			•
Pump 3, multi-pump system			•
Pump 4, multi-pump system			•

Settings	NBE, NBGE, NKE, NBSE, VLSE	NBE, NBGE, NKE, NBSE Series 2000; VLSE with Delta $\rho$ sensor	Multipump system
Setpoint	•	•	•
Operating mode	•	•	•
Set manual speed	•	•	•
Set user defined speed	•	•	•
Control mode	•	•	•
Setting the proportional pressure		•	•
Analog inputs	•	•	•
Analog input 1, setup	•	•	•
Analog input 2, setup	•	•	•
Analog input 3, setup	•	•	•
Grundfos Direct Sensor	•	• 5)	•
Pt100/1000 inputs	•	•	•
Pt100/1000 input 1, setup	•	•	•
Pt100/1000 input 2, setup	•	•	•
Digital inputs	•	•	•
Digital input 1, setup	•	•	•
Digital input 2, setup	•	•	•
Digital inputs/outputs	•	•	•
Digital input/output 3, setup	•	•	•
Digital input/output 4, setup	•	•	•
Relay outputs	•	•	•
Relay output 1	•	•	•
Relay output 2	•	•	•
Analog output	•	•	•
Output signal	•	•	•
Function of analog output	•	•	•
Controller settings	•	•	•
Operating range	•	•	•
Setpoint influence	•	•	•
Ext. setpoint infl.	•	•	•
Predefined setpoint			
Monitoring functions	•	•	•
Motor bearing monitoring	•	•	•
Alarm handling	•	•	•
Motor bearing maintenance	•	•	•
Limit-exceeded function	•	•	•
Special functions	•	•	•
Pulse flowmeter setup	•	•	•
Ramps	•	•	•
Standstill heating	•	•	•
Communication	•	•	•
Pump number	•	•	•
Enable/disable radio comm.	•	•	•
Enable/disable Bluetooth comm.	•	•	•
Initiate Bluetooth connection	•	•	•

Settings	NBE, NBGE, NKE, NBSE, VLSE	NBE, NBGE, NKE, NBSE Series 2000; VLSE with Delta $\rho$ sensor	Multipump system
Setup of AYB terminals	•	•	•
Setup of Ethernet	•	•	•
<b>General settings</b>	•	•	•
Language	•	•	•
Set date and time	•	•	•
Units	•	•	•
Enable/disable settings	•	•	•
Delete history	•	•	•
Define Home display	•	•	•
Display settings	•	•	•
Store actual settings	•	•	•
Recall stored settings	•	•	•
Run start-up guide	•	•	•

5) Not VLSE

Assist	NBE, NBGE, NKE, NBSE, VLSE	NBE, NBGE, NKE, NBSE Series 2000; VLSE with Delta $\rho$ sensor	Multipump system
Assisted pump setup	•	•	•
Setup, analog input	•	•	•
Setting of date and time	•	•	•
Setup of multi-pump system	•	•	•
Description of control mode	•	•	•
Assisted fault advice	•	•	•

## 6.2 Grundfos GO

### CAUTION



#### Radiation

Minor or moderate personal injury

- Locate the product at a minimum distance of 8 inches (20 cm) from any body parts. Human tissue may be heated by RF energy.



Installers and end users must be provided with these installation and operating instructions and operating conditions for satisfying RF exposure compliance.

The product is designed for wireless communication with Grundfos GO using Bluetooth (BLE).

Grundfos GO enables you to set functions and gives you access to status overviews, technical product information and current operating parameters.

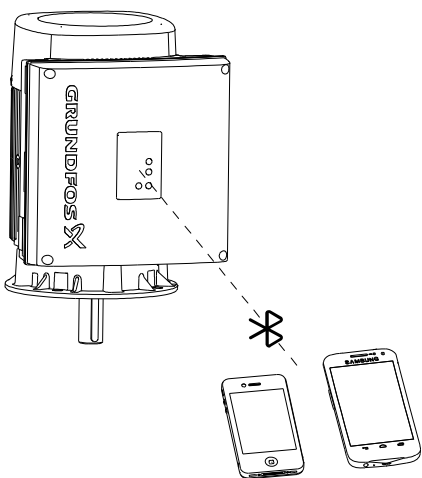

TM082930

### 6.2.1 Communication

When Grundfos GO initiates communication with the product, the indicator light in the centre of Grundfos Eye flashes green.

On products fitted with the HMI 200 operating panel, you can enable communication by pressing the **Communication** button.

On products fitted with the HMI 300 operating panel, the display indicates that a wireless device is trying to connect to the product. Press **OK** on the operating panel to connect the product with Grundfos GO, or press the **Home** button to reject connection.

Symbol	Description
OK	Press <b>OK</b> on the operating panel to connect the product with Grundfos GO.
	Press the <b>Home</b> button to reject connection.

#### 6.2.1.1 Bluetooth communication

Bluetooth communication can take place at distances up to 32.8 ft (10 m). The first time Grundfos GO communicates with the product, you enable communication by pressing the **Communication** button or **OK** on the operating panel.

Later when communication takes place, the product is recognised by Grundfos GO, and you can select the product from the **List** menu.

## 6.2.2 Menu overview for Grundfos GO

	NBE, NBGE, NKE, NBSE, VLSE	NBE, NBGE, NKE, NBSE Series 2000; VLSE with Delta $\rho$ sensor	Multipump system
<b>Dashboard</b>	.	.	.
<b>View all metrics</b>	NBE, NBGE, NKE, NBSE, VLSE	NBE, NBGE, NKE, NBSE Series 2000; VLSE with Delta $\rho$ sensor	Multipump system
<b>Pump and application</b>	.	.	.
Actual controlled value	.	.	.
Acc. flow, specific energy	.	.	.
Energy consumption	.	.	.
Energy consumption, system	.	.	.
Power consumption	.	.	.
Power consumption, system	.	.	.
Motor bearing service	.	.	.
Resulting setpoint	.	.	.
Resulting system setpoint	.	.	.
Motor speed	.	.	.
Pump 1	.	.	.
Pump 2	.	.	.
Pump 3	.	.	.
Pump 4	.	.	.
<b>Operating Log</b>	.	.	.
Operating hours	.	.	.
Operating hours, system	.	.	.
Motor current	.	.	.
Number of starts	.	.	.
<b>Inputs/outputs</b>	.	.	.
Analog input 1	.	.	.
Analog input 2	.	.	.
Analog input 3	.	.	.
Analog, Output	.	.	.
Pt100/1000 input 1	.	.	.
Pt100/1000 input 2	.	.	.
Digital input 1	.	.	.
Digital input 2	.	.	.
Digital input/output 3	.	.	.
Digital input/output 4	.	.	.
<b>Monitored metrics</b>	.	.	.
Ambient temperature	.	.	.
Differential pressure	.	.	.
Differential pressure, inlet/outlet	.	.	.
Differential temperature, external	.	.	.
External pressure 1	.	.	.
External pressure 2	.	.	.

View all metrics	NBE, NBGE, NKE, NBSE, VLSE	NBE, NBGE, NKE, NBSE Series 2000; VLSE with Delta $\rho$ sensor	Multipump system
Feed tank pressure	•	•	•
Flow rate	•	•	•
Pressure : inlet	•	•	•
Pressure : outlet	•	•	•
Other parameter	•	•	•
Tank pressure, external	•	•	•
Temperature 1	•	•	•
Temperature 2	•	•	•
<b>Fitted modules</b>	•	•	
Functional module	•	•	
Power board	•	•	
CIM module	•	•	
Operating panel	•	•	
Settings	NBE, NBGE, NKE, NBSE, VLSE	NBE, NBGE, NKE, NBSE Series 2000; VLSE with Delta $\rho$ sensor	Multipump system
<b>Pump and application</b>	•	•	•
Pump name	•	•	•
Control mode	•	•	•
Operating mode	•	•	•
Setpoint	•	•	•
Set user-defined speed	•	•	•
Operating range	•	•	•
Controller	•	•	•
External setpoint funct.	•	•	
Predefined setpoint	•	•	•
Setting the proportional pressure		•	
Buttons on product	•	•	
Service	•	•	
Alternating operation, time			•
Sensor to be used			•
Time for pump changeover			•
<b>Inputs/outputs</b>	•	•	
Analog input 1	•	•	
Analog input 2	•	•	
Analog input 3	•	•	
Grundfos Direct Sensor		• 6)	
Analog output	•	•	
Pt100/1000 input 1	•	•	
Pt100/1000 input 2	•	•	
Digital input 1	•	•	
Digital input 2	•	•	
Digital input/output 3	•	•	
Digital input/output 4	•	•	
Relay output 1	•	•	

Settings	NBE, NBGE, NKE, NBSE, VLSE	NBE, NBGE, NKE, NBSE Series 2000; VLSE with Delta p sensor	Multipump system
Relay output 2	•	•	
<b>Monitoring functions</b>	•	•	•
Alarm handling	•	•	
Limit 1 exceeded	•	•	•
Limit 2 exceeded	•	•	•
Motor bearing monitoring	•	•	
<b>Special functions</b>	•	•	•
Pulse flow meter	•	•	
Ramps	•	•	
Standstill heating	•	•	
<b>Communication</b>	•	•	
Bluetooth communication <sup>7)</sup>	•	•	
Radio communication <sup>7)</sup>	•	•	
GENIbus Number	•	•	
Connectivity and port settings	•	•	
<b>General</b>	•	•	
Connection code	•	•	
Date and time	•	•	
Firmware	•	•	
Store settings	•	•	
Recall settings	•	•	
Undo	•	•	
Unit configuration	•	•	

6) Not VLSE

7) Not FM311

Alarms and warnings	NBE, NBGE, NKE, NBSE, VLSE	NBE, NBGE, NKE, NBSE Series 2000; VLSE with Delta p sensor	Multipump system
Alarm log	•	•	•
Warning log	•	•	•

Setup	NBE, NBGE, NKE, NBSE, VLSE	NBE, NBGE, NKE, NBSE Series 2000; VLSE with Delta p sensor	Multipump system
Assisted pump setup	•	•	
Assisted fault advice	•	•	
Application wizard	•	•	
Multi-pump setup	•	•	•

## 6.3 Grundfos GO Link

The product is designed for wired or wireless communication with the Grundfos GO Link.

The Grundfos GO Link enables you to set functions and gives you access to status overviews, configuration and current operating parameters.

Use the Grundfos GO Link together with the following interfaces:

- Ethernet cable (Only FM310 and FM311)
- Grundfos MI 301 - USB - Wired/wireless (Only HMI 200 and HMI 300)
- Grundfos PC Tool Link - USB - Wired.

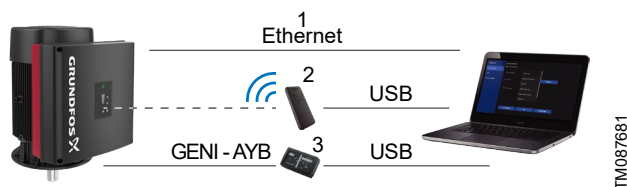

Grundfos GO Link setup

Pos.	Description
1	Ethernet cable: Standard Ethernet cable CAT5/CAT6
2	Grundfos MI 301: Separate radio equipment enabling radio communication <sup>8)</sup>
3	Grundfos PC Tool Link: Separate module enabling wired connection to the pump <sup>8)</sup>

<sup>8)</sup> Use the module together with a USB cable to connect to a laptop.

### 6.3.1 Communication

When Grundfos GO Link initiates communication with the product, it is done using different verification methods.

Select the interface connected to the pump:

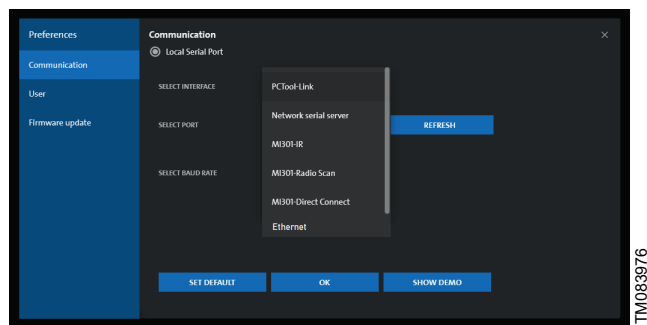

### 6.3.2 Ethernet

Wired connection can take place using an Ethernet cable connected directly between a laptop and the RJ45 interface in the pump or via a local network having both the pump and the laptop connected to the same network.

To establish a secure connection between the laptop and the pump, the user will have to go through a verification process.

Connecting to a pump can either happen by scanning for a connected product, which can be a direct Ethernet connection, or the pump is connected to a local network or a connection via the pump IP address.

Initiate connection from Grundfos GO Link and follow onscreen instructions.

### 6.3.3 Grundfos MI 301

Radio communication can take place at distances up to 98 ft (30 m). The first time Grundfos GO Link communicates with the product, you enable communication by pressing the **Radio communication** button or **OK** on the operating panel. Select either MI301-Direct connect or MI301-Radio. When communication takes place, the product is recognized by Grundfos GO Link, and you can connect using Direct connect or Radio scan without having to run a verification.

### 6.3.4 Grundfos PC Tool Link

Wired connection can take place using Grundfos PC Tool connected to the AYB terminals of the pump. Since Grundfos GO Link is wired to the pump within a short distance, no verification is needed. A direct connection will be established.



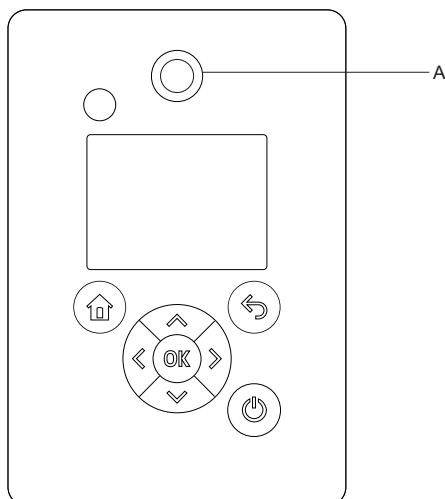

## 6.4 Grundfos Eye



The operating condition of the motor is indicated by Grundfos Eye on the motor operating panel. See figure below (A).

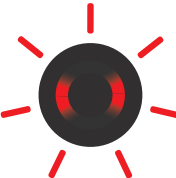
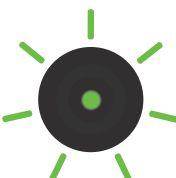

TM084637

Grundfos Eye indicator light

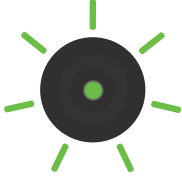
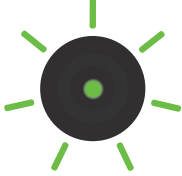
Indicator light	Indication	Description
	No lights are on.	<b>Power off</b> The motor is not running.
	Two opposite green indicator lights are rotating.	<b>Power on</b> The motor is running. The indicator lights are rotating in the direction of rotation of the motor when seen from the non-drive end.
	Two opposite green indicator lights are permanently on.	<b>Power on</b> The motor is not running.
	One yellow indicator light is rotating.	<b>Warning</b> The motor is running. The indicator light is rotating in the direction of rotation of the motor when seen from the non-drive end.
	One yellow indicator light is permanently on.	<b>Warning</b> The motor has stopped.
	Two opposite red indicator lights are flashing simultaneously.	<b>Alarm</b> The motor has stopped.
	The green indicator light in the middle flashes quickly four times.	Grundfos Eye flashes four times when you press the Grundfos Eye symbol next to the motor name in Grundfos GO.

Indicator light	Indication	Description
	The green indicator light in the middle is flashing continuously.	You have selected the motor in Grundfos GO, and the motor is ready to be connected.
	The green indicator light in the middle flashes quickly for a few seconds.	The motor is controlled by Grundfos GO or exchanging data with Grundfos GO.
	The green indicator light in the middle is permanently on.	The motor is connected to Grundfos GO.

## 7. Setting the product

You can set control functions via Grundfos GO, Grundfos GO Link or the HMI 300 or HMI 301 operating panel.

- If only one function name is mentioned, it refers to both Grundfos GO and the operating panel.
- If a function name is mentioned in a parenthesis, it refers to a function on the operating panel.

### 7.1 Setpoint

Pump variant	Setpoint
NBE, NBGE, NKE, NBSE, VLSE	•
NBE, NBGE, NKE, NBSE Series 2000; VLSE with Delta p sensor	•

When you have selected the desired control mode, set the setpoint.

### 7.2 Operating mode

Pump variant	Operating mode
NBE, NBGE, NKE, NBSE, VLSE	•
NBE, NBGE, NKE, NBSE Series 2000; VLSE with Delta p sensor	•

#### Possible operating modes

<b>Normal</b>	The product runs according to the selected control mode.
<b>Stop</b>	The product stops.
<b>Min.</b>	The product runs at minimum speed. You can use the minimum curve mode in periods in which a minimum flow is required. When operating according to the minimum curve, the pump is operating like an uncontrolled pump.
<b>Max.</b>	The product runs at maximum speed. You can use the maximum curve mode in periods in which a maximum flow is required. When operating according to the maximum curve, the pump is operating like an uncontrolled pump.
<b>Manual</b>	The product is operating at a manually set speed, and the setpoint via bus and setpoint influence function are overruled.
<b>User-defined speed</b>	The product is operating at a speed set by the user.

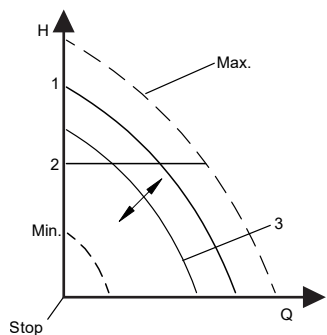

TM064024

Pos.	Description
1	<b>Normal</b>
2	<b>Normal</b>
3	<b>Manual</b>

### 7.3 Set manual speed

Pump variant	Set manual speed
NBE, NBGE, NKE, NBSE, VLSE	•
NBE, NBGE, NKE, NBSE Series 2000; VLSE with Delta p sensor	•

The function is only available in the HMI 300 and 301 operating panels.

Use this function to set the speed in percentage of the maximum speed. When you have set the operating mode to **Manual**, the product starts running at the set speed.

With Grundfos GO, you can set the speed via the **Setpoint** menu.

### 7.4 Set user-defined speed

Use this function to set the motor speed in percentage of the maximum speed. When you set the operating mode to **User-defined speed**, the motor starts running at the set speed.

### 7.5 Control mode

Pump variant	Control mode
NBE, NBGE, NKE, NBSE, VLSE	•
NBE, NBGE, NKE, NBSE Series 2000; VLSE with Delta p sensor	•

You can choose between the following control modes:

- **Prop. pressure** (proportional pressure)
- **Const. pressure** (constant pressure)
- **Const. temp.** (constant temperature)
- **Con. diff. press.** (constant differential pressure)
- **Con. diff. temp.** (constant differential temperature)
- **Const. flow rate** (constant flow rate)
- **Const. level** (constant level)
- **Const. other val.** (constant other value)
- **Const. curve** (constant curve).

### 7.5.1 Proportional pressure

Pump variant	Proportional pressure
NBE, NBGE, NKE, NBSE, VLSE	-
NBE, NBGE, NKE, NBSE Series 2000; VLSE with Delta p sensor	•

The head of the pump is reduced at decreasing water demand and increased at rising water demand. See the figure below.

This control mode is especially suitable in systems with relatively large pressure losses in the distribution pipes. The head of the pump increases proportionally to the flow in the system to compensate for the large pressure losses in the distribution pipes.

The setpoint can be set with an accuracy of 4 inches (10 cm). The head against a closed valve is half the setpoint. The setting range is between 25 % and 90 % of maximum head.

For more information about settings, see section on proportional-pressure setup.

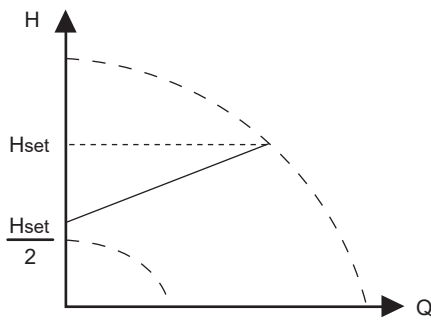

Proportional pressure

Example:

- Factory-fitted differential-pressure sensor.

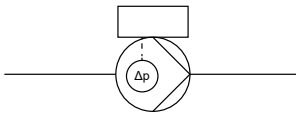

Proportional pressure

#### Controller settings

For the recommended controller settings, see the section on the controller.

### 7.5.2 Constant pressure

Pump variant	Constant pressure
NBE, NBGE, NKE, NBSE, VLSE	•
NBE, NBGE, NKE, NBSE Series 2000; VLSE with Delta p sensor	•

We recommend this control mode if the pump is to deliver a constant pressure, independently of the flow in the system. The pump maintains a constant pressure independently of the flow rate.

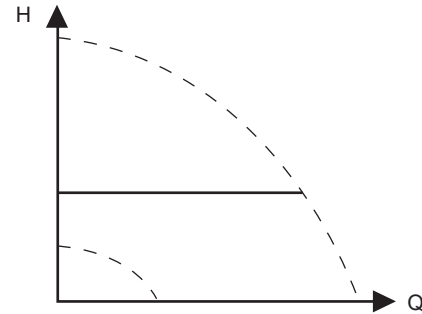

Constant pressure

This control mode requires an external pressure sensor as shown in the examples below. You can set the pressure sensor in the **Assist** menu. See the section on assisted pump setup. The setting range is between 12.5 % and 100 % of maximum head.

Example:

- One external pressure sensor

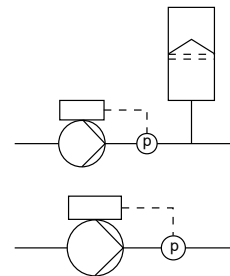

#### Controller settings

For recommended controller settings, see the section on the controller.

TM057909

TM057880

TM057901

TM057881

TM057882

### 7.5.3 Constant temperature

Pump variant	Constant temperature
NBE, NBGE, NKE, NBSE, VLSE	•
NBE, NBGE, NKE, NBSE Series 2000; VLSE with Delta p sensor	•

This control mode ensures a constant temperature. Constant temperature is a comfort control mode that you can use in domestic hot-water systems to control the flow to maintain a constant temperature in the system.

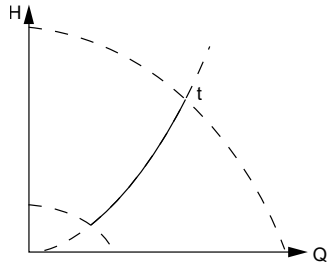

#### Constant temperature

This control mode requires an external temperature sensor as shown in the example below.

Example:

- One external temperature sensor

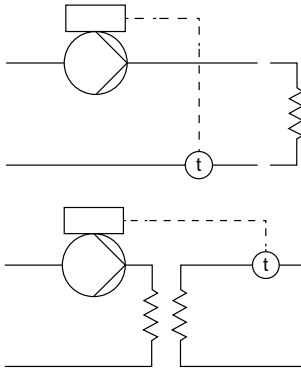

TM057900

TM057884

TM057885

#### Controller settings

For the recommended controller settings, see the section on the controller.

### 7.5.4 Constant differential pressure

Pump variant	Constant differential pressure
NBE, NBGE, NKE, NBSE, VLSE	•
NBE, NBGE, NKE, NBSE Series 2000; VLSE with Delta p sensor	•

The pump maintains a constant differential pressure, independently of the flow rate in the system. This control mode is primarily suitable for systems with relatively small pressure losses.

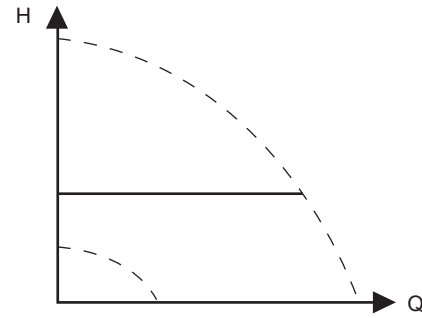

TM057901

#### Constant differential pressure

The setting range is between 12.5 % and 100 % of maximum head. This control mode requires either an internal or external differential-pressure sensor or two external pressure sensors as shown in the examples below.

Examples:

- Factory-fitted differential-pressure sensor.

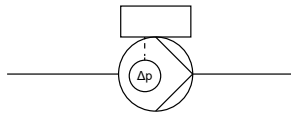

TM057880

- One external differential-pressure sensor.

The pump uses the input from the sensor to control the differential pressure.

You can set the sensor manually or by using the **Assist** menu. See the section on assisted pump setup.

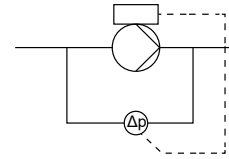

TM057886

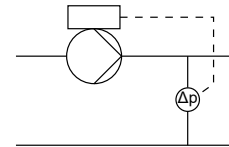

TM057887

- Two external pressure sensors.

Constant differential-pressure control is achievable with two individual pressure sensors. The pump uses the inputs from the two sensors and calculates the differential pressure.

The sensors must have the same unit and must be set as feedback sensors. You can set the sensors manually, sensor by sensor, or by using the **Assist** menu. See the section on assisted pump setup.

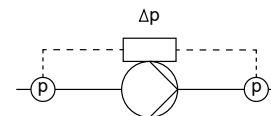

TM057888

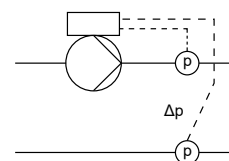

TM057889

#### Controller settings

For recommended controller settings, see the section on the controller.

### 7.5.5 Constant differential temperature

Pump variant	Constant differential temperature
NBE, NBGE, NKE, NBSE, VLSE	•
NBE, NBGE, NKE, NBSE Series 2000; VLSE with Delta p sensor	•

The pump maintains a constant differential temperature in the system and the pump performance is controlled according to this.

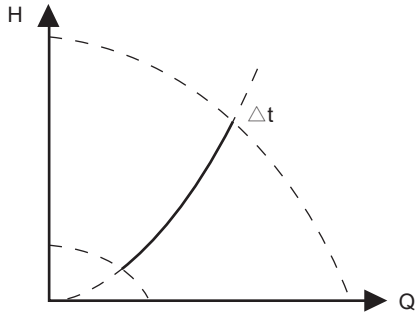

TM057954

#### Constant differential temperature

This control mode requires either two temperature sensors or one external differential-temperature sensor. See the examples below. The temperature sensors can either be analog sensors connected to two of the analog inputs or two Pt100/1000 sensors connected to the Pt100/1000 inputs, if these are available on the specific pump. Set the sensor in the **Assist** menu under **Assisted pump setup**. See the section on assisted pump setup.

Examples:

- Two external temperature sensors.  
Constant differential-temperature control is achievable with two temperature sensors. The pump uses the inputs from the two sensors and calculates the differential temperature. The sensors must have the same unit and must be set as feedback sensors. You can set the sensors manually, sensor by sensor, or by using the **Assist** menu. See the section on assisted pump setup.

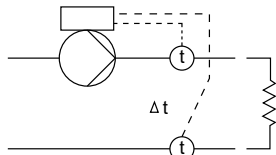

TM057894

- One external differential-temperature sensor.  
The pump uses the input from the sensor to control the differential temperature. You can set the sensor manually or by using the **Assist** menu. See the section on assisted pump setup.

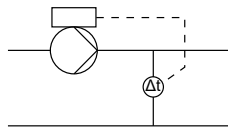

TM057931

#### Controller settings

For recommended controller settings, see the section on the controller.

### 7.5.6 Constant flow rate

Pump variant	Constant flow rate
NBE, NBGE, NKE, NBSE, VLSE	•
NBE, NBGE, NKE, NBSE Series 2000; VLSE with Delta p sensor	•

The pump maintains a constant flow in the system, independently of the head.

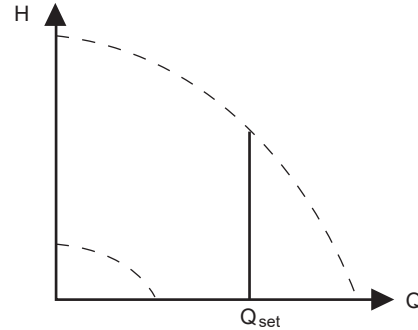

TM057955

#### Constant flow rate

This control mode requires an external flow sensor. See the example below.

Example:

- One external flow sensor.

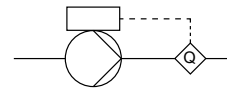

TM057895

#### Constant flow rate

#### Controller settings

For recommended controller settings, see the section on the controller.

7.5.7 Constant level

Pump variant	Constant level
NBE, NBGE, NKE, NBSE, VLSE	•
NBE, NBGE, NKE, NBSE Series 2000; VLSE with Delta p sensor	•

The pump maintains a constant level, independently of the flow rate.

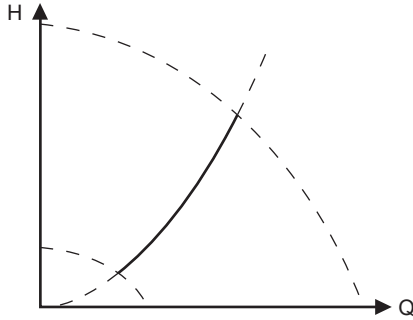

Constant level

This control mode requires an external level sensor. The pump can control the level in a tank in two ways (see the figure above):

- As an emptying function where the pump draws the liquid from the tank.
- As a filling function where the pump pumps the liquid into the tank.

The type of level control function depends on the setting of the built-in controller.

Example:

- One external level sensor with emptying function.

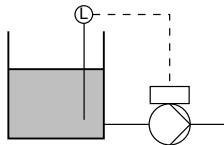

- One external level sensor with filling function.

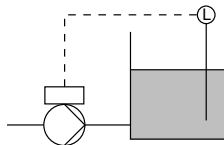

Controller settings

For recommended controller settings, see the section on the controller.

7.5.8 Constant other value

Pump variant	Constant other value
NBE, NBGE, NKE, NBSE, VLSE	•
NBE, NBGE, NKE, NBSE Series 2000; VLSE with Delta p sensor	•

Use this control mode to control a value which is not available in the **Control mode** menu. To measure the controlled value, connect a sensor to one of the analog inputs. The controlled value is shown in percentage of the sensor range.

7.5.9 Constant curve

Pump variant	Constant curve
NBE, NBGE, NKE, NBSE, VLSE	•
NBE, NBGE, NKE, NBSE Series 2000; VLSE with Delta p sensor	•

Use this control mode to control the motor speed.

You can set the desired speed in percentage of the maximum speed in the range from user-set minimum speed to user-set maximum speed.

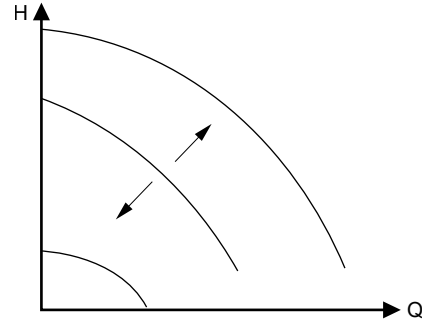

7.6 Setting the proportional pressure

Pump variant	Setting the proportional pressure
NBE, NBGE, NKE, NBSE, VLSE	-
NBE, NBGE, NKE, NBSE Series 2000; VLSE with Delta p sensor	•

7.6.1 Control curve function

You can set the proportional curve either to quadratic or linear to match the system curve.

7.6.2 Zero flow head

You can set this value in percentage of the setpoint, and define how much the setpoint must be reduced at a closed valve. With a setting of 100 %, the control mode is equal to the constant differential pressure.

### 7.7 Analog inputs

Pump variant	Analog inputs
NBE, NBGE, NKE, NBSE, VLSE	•
NBE, NBGE, NKE, NBSE Series 2000; VLSE with Delta p sensor	•

The inputs and outputs available depend on the functional module fitted in the motor.

Functional module	Analog input 1 (Terminal AI1)	Analog input 2 (Terminal AI2)	Analog input 3 (Terminal AI3)
FM310	•	•	•
FM311	•	•	•

#### Wiring examples:

These connection scenarios are also valid for connection to analog input 2 and analog input 3.

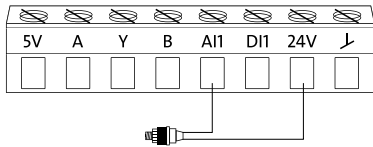

TM083181

2-wire sensor, 0/4-20 mA

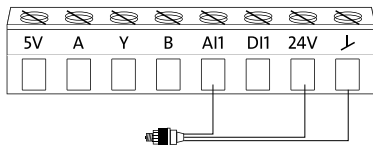

TM083182

3-wire sensor, 0/4-20 mA

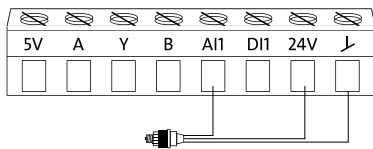

TM083182

3-wire sensor, 0.5 - 3.5 V, 0-5 V, 0-10 V

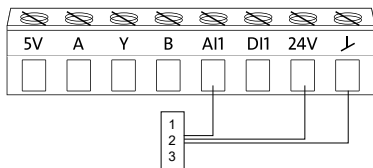

TM083184

Setpoint influence, 0.5 - 3.5 V, 0-5 V, 0-10 V; 0/4-20 mA

Pos.	Description
1	Potentiometer
2	PLC
3	External controller

To set the input, make the settings below:

#### Function

You can set the inputs to these functions:

- **Not active**
- **Feedback sensor**  
The sensor is used for the selected control mode.
- **Setpoint influence**  
The input signal is used for influencing the setpoint.
- **Other function**  
The sensor input is used for measurement or monitoring.

#### Measured parameter

Select one of the below parameters to be measured in the system by the sensor connected to the input.

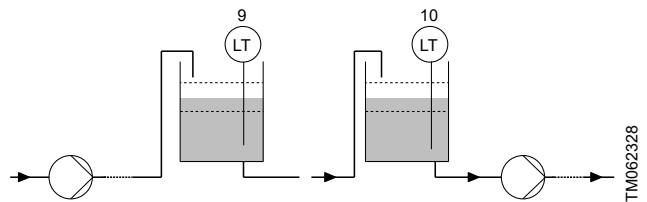
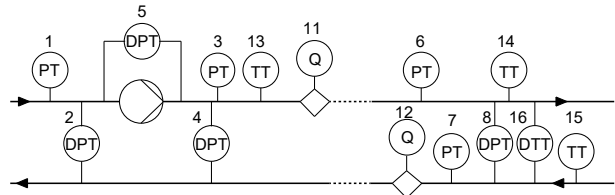

TM083181

TM062328

Pos.	Sensor function/measured parameter
1	Inlet pressure
2	Diff. press., inlet
3	Outlet pressure
4	Diff. press.,outlet
5	Diff. press.,pump
6	Press. 1, external
7	Press. 2, external
8	Diff. press., ext.
9	Storage tank level
10	Feed tank level
11	Pump flow
12	Flow, external
13	Liquid temp.
14	Temperature 1
15	Temperature 2
16	Differential temp.
Not shown	Ambient temp.
Not shown	Other parameter

**Unit**

Parameter	Available units
Pressure	bar, m, kPa, psi, ft
Level	cm, m, ft, in
Pump flow	m <sup>3</sup> /h, l/s, yd <sup>3</sup> /h, gpm
Liquid temperature	°C, °F
Other parameter	%

**Electrical signal**

Available signal types:

- 0.5 - 3.5 V
- 0-5 V
- 0-10 V
- 0-20 mA
- 4-20 mA.

**Sensor range, minimum value**

Set the minimum value of the connected sensor.

**Sensor range, maximum value**

Set the maximum value of the connected sensor.

**7.7.1 Setting two sensors for differential measurement**

Two analog sensors must be installed and connected electrically to measure a parameter at two different locations in a system.

The pressure, temperature and flow parameters can be used for differential measurement.

- Set the analog inputs according to the measured parameter:

Parameter	Sensor 1, measured parameter	Sensor 2, measured parameter
Pressure, option 1	<b>Inlet pressure</b>	<b>Outlet pressure</b>
Pressure, option 2	<b>Press. 1, external</b>	<b>Press. 2, external</b>
Flow	<b>Pump flow</b>	<b>Flow, external</b>
Temperature	<b>Temperature 1</b>	<b>Temperature 2</b>



If you want to use the **Con. diff. press.**, **Con. diff. temp.** or **Const. flow rate** control modes, you must configure both sensors as **Feedback sensor**.

**7.8 Grundfos Direct Sensor**

Pump variant	Grundfos Direct Sensor
NBE, NBGE, NKE, NBSE, VLSE	-
NBE, NBGE, NKE, NBSE Series 2000; VLSE with Delta p sensor	• <sup>9)</sup>

<sup>9)</sup> Not VLSE with Delta p sensor, as it is an analog sensor.

Grundfos Direct Sensor is a digital sensor that auto detects range and unit.

Grundfos Direct Sensor always has the capability to also measure the media temperature. The pump will automatically detect range and unit of the temperature sensor.

For information about the functions and measured parameters of each sensor, see the sections on the sensor, temperature and dry-running protection.

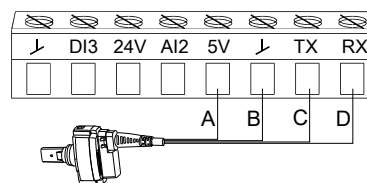
**Wiring example:**

TM086416

Designation	Color
A	Brown
B	Green
C	White
D	Yellow

**Factory setting**

See the section on factory settings.

## 7.9 Pt100/1000 inputs

Pump variant	Pt100/1000 inputs
NBE, NBGE, NKE, NBSE, VLSE	•
NBE, NBGE, NKE, NBSE Series 2000; VLSE with Delta $\rho$ sensor	•

The inputs and outputs available depend on the functional module fitted in the motor.

Functional module	Pt100/1000 input 1 (Terminals PT1, GND)	Pt100/1000 input 2 (Terminals PT2, GND)
FM310	•	•
FM311	•	•

### Wiring example:

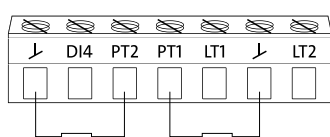

TM083189

### Pt100/1000

To set the input, choose one of the below settings.

**Function** You can set the inputs to these functions:

- **Not active**
- **Feedback sensor**  
The sensor is used for the selected control mode.
- **Setpoint influence**  
The input signal is used for influencing the setpoint.
- **Other function**  
The sensor input is used for measurement or monitoring.

### Measured parameter

Select one of the below parameters to be measured in the system by the sensor connected to the input.

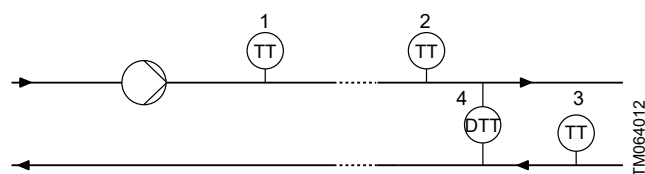

TM064012

Pos.	Sensor function/measured parameter
1	Liquid temp.
2	Temperature 1
3	Temperature 2
4	Differential temp.
Not shown	Ambient temp.

### Measuring range

-58 to 399 °F (-50 to +204 °C).

## 7.10 Digital inputs

Pump variant	Digital inputs
NBE, NBGE, NKE, NBSE, VLSE	•
NBE, NBGE, NKE, NBSE Series 2000; VLSE with Delta $\rho$ sensor	•

The inputs and outputs available depend on the functional module fitted in the motor.

Functional module	Digital input 1 (Terminals DI1, GND)	Digital input 2 (Terminals DI2, GND)
FM310	•	•
FM311	•	•

### Wiring example:

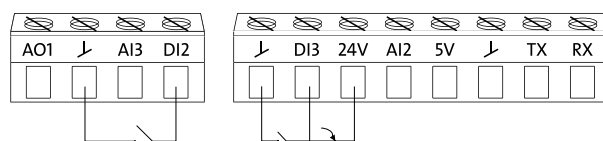

TM083186

### Digital input

To set the input, make the settings below:

### Function

You can set the inputs to these functions:

- **Not active**  
When set to **Not active**, the input has no function.
- **Ext. stop**  
When the input is deactivated, open circuit, the motor stops.
- **Min.** (minimum speed)  
When the input is activated, the motor runs at the set minimum speed.
- **Max.** (maximum speed)  
When the input is activated, the motor runs at the set maximum speed.
- **User defined speed**  
When the input is activated, the motor runs at a speed set by the user.
- **External fault**  
When the input is activated, a timer is started. If the input is activated for more than 5 seconds, the motor stops and a fault is indicated. The function depends on input from external equipment.
- **Alarm resetting**  
When the input is activated, a fault indication, if any, is reset.
- **Dry running**  
When this function is selected, a lack of inlet pressure or water shortage (dry running) can be detected. When this happens, the pump stops. The pump cannot restart as long as the input is activated. This requires the use of an accessory such as these:
  - a pressure switch installed on the inlet side of the pump
  - a float switch installed on the inlet side of the pump.
- **Accumulated flow**  
When this function is selected, the accumulated flow can be registered. This requires the use of a flowmeter which can give a feedback signal as a pulse per defined volume of water.
- **Reverse rotation**

This function reverses the direction of rotation of the motor.

• **Predefined setpoint 1**

The function applies only to digital input 2.

When you set digital inputs to a predefined setpoint, the pump operates according to a setpoint based on a combination of the activated digital inputs.

• **Activate output**

When this function is selected, the related digital output is activated. This is done without any changes to pump operation.

• **Local motor stop**

When the function is selected, the given motor in a multimotor system setup stops without affecting the performance of the other motors in the system.

The priority of the selected functions are interdependent.

A stop command always has the highest priority.

**Activation of digital inputs**

You can set the digital inputs to trigger on either Closed contact or Open contact. Selecting the trigger function can only be set via Grundfos GO Link.

The digital inputs can be activated either as active low or active high.

The digital inputs will react as described in the table below:

Activate/ Closed contact	Deactivate/Open contact
GND/0V	Floating/3-24V

**7.10.1 Timer function for a digital input**

**Activation delay**

The activation delay (T1) is the time between the digital signal and the activation of the selected function.

Range: 0-6000 seconds.

**Duration time**

Available modes:

- **Not active**
- **Active with interrupt**
- **Active without interrupt**
- **Active with after-run.**

The duration time (T2) is the time which, together with the mode, determines how long the selected function is active.

Range: 0 - 15,000 seconds.

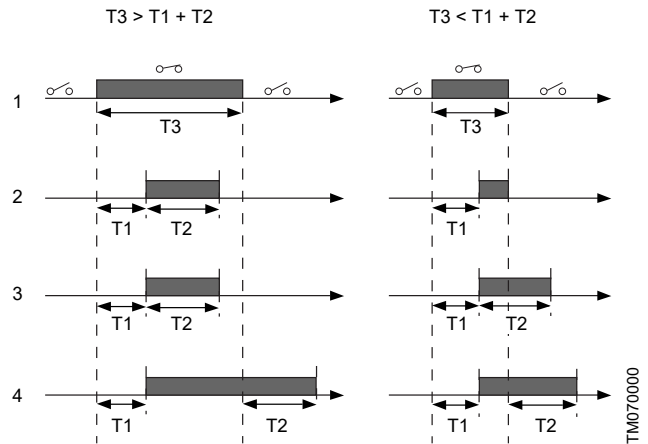

Pos.	Description
1	Digital input.
2	Active with interrupt.
3	Active without interrupt.
4	Active with after-run.
T1	Activation delay
T2	Duration time
T3	The period of time when the digital input is activated.

## 7.11 Digital inputs/outputs

Pump variant	Digital inputs/outputs
NBE, NBGE, NKE, NBSE, VLSE	•
NBE, NBGE, NKE, NBSE Series 2000; VLSE with Delta p sensor	•

The inputs and outputs available depend on the functional module fitted in the motor.

Functional module	Digital input/output 3 (Terminals DI3, GND)	Digital input/output 4 (Terminals DI4, GND)
FM310	•	•
FM311	•	•

You can select whether the interface is to be used as an input or output. The output is an open collector. You can connect the open collector to, for example, an external relay or a controller such as a PLC.

Wiring example:

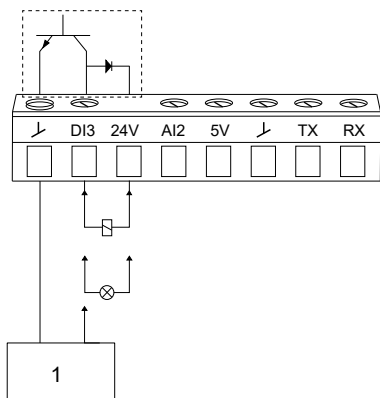

TM083187

*Digital output, open collector*

Pos.	Description
1	External controller

### Mode

You can set the digital input or output 3 and 4 to act as a digital input or digital output.

Functions if the digital input or output is set to input:

- Not active
- Ext. stop
- Min.
- Max.
- User defined speed
- External fault
- Alarm resetting
- Dry running
- Accumulated flow
- Reverse rotation
- Predefined setpoint 2 (digital input/output 3)
- Predefined setpoint 3 (digital input/output 4)
- Local motor stop
- Activate output

Functions if the digital input or output is set to output:

- Not active
- Ready
- Alarm
- Operation
- Pump running
- Warning
- Limit 1 exceeded
- Limit 2 exceeded
- Digital input 1, state
- Digital input 2, state
- Digital input 3, state
- Digital input 4, state

## 7.12 Signal relay (Relay outputs)

Pump variant	Signal relay
NBE, NBGE, NKE, NBSE, VLSE	•
NBE, NBGE, NKE, NBSE Series 2000; VLSE with Delta p sensor	•

The motor has two outputs for potential-free signals via two internal relays.

Functional module	Signal relay 1 (Terminals NC, C1, NO)	Signal relay 2 (Terminals NC, C2, NO)
FM310	•	•
FM311	•	•

Wiring example:

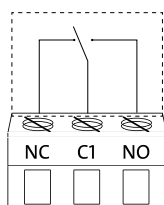

TM083188

### Relay output

#### Functions

You can configure the signal relays to be activated when the product changes to one of the following states:

- **Not active**  
The relay has been deactivated.
- **Ready**  
The motor may be running or is ready to run, and no alarms are active.
- **Alarm**  
There is an active alarm, and the motor is stopped.
- **Operating (Operation)**  
**Operating** equals **Running**, but the motor is still in operation when it is stopped, for example, by the **Stop function** or **Limit exceeded**.
- **Running (Pump running)**  
The motor shaft is rotating.
- **Warning**  
There is an active warning.
- **Limit 1 exceeded**  
When you have set this function and the limit is exceeded, the signal relay is activated.
- **Limit 2 exceeded**  
When you have set this function and the limit is exceeded, the signal relay is activated.
- **External fan control (Control of external fan)**  
When you select this function, the relay is activated if the internal temperature of the motor electronics reaches a preset limit value. In this way the relay activates external cooling to add additional cooling to the motor.
- **Digital input 1, state**  
Follow digital input 1. If digital input 1 is triggered, the digital output is also triggered.
- **Digital input 2, state**

Follow digital input 2. If digital input 2 is triggered, the digital output is also triggered.

- **Digital input 3, state**

Follow digital input 3. If digital input 3 is triggered, the digital output is also triggered.

- **Digital input 4, state**

Follow digital input 4. If digital input 4 is triggered, the digital output is also triggered.

## 7.13 Analog output

Pump variant	Analog output
NBE, NBGE, NKE, NBSE, VLSE	•
NBE, NBGE, NKE, NBSE Series 2000; VLSE with Delta p sensor	•

The inputs and outputs available depend on the functional module fitted in the motor.

Functional module	Analog output (Terminals AO, GND)
FM310	•
FM311	•

Wiring example:

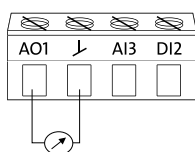

TM083185

Analog output, 0/4-20 mA, 0-10 V

The analog output enables external control systems to read specific operating data.

To set the analog output, make the following settings.

### Output signal

Possible signal types:

- 0-10 V
- 0-20 mA
- 4-20 mA.

### Function of analog output

Actual speed	
<b>0 %</b>	<b>100 %</b>
0 V	10 V
0 mA	20 mA
4 mA	20 mA

Sensor value	
Minimum	Maximum
0 V	10 V
0 mA	20 mA
4 mA	20 mA

Resulting setpoint	
<b>0 %</b>	<b>100 %</b>
0 V	10 V
0 mA	20 mA
4 mA	20 mA

Motor load	
<b>0 %</b>	<b>100 %</b>
0 V	10 V
0 mA	20 mA
4 mA	20 mA

Motor current		
<b>0 %</b>	<b>100 %</b>	<b>200 %</b>
0 V	5 V	10 V
0 mA	10 mA	20 mA
4 mA	12 mA	20 mA

Limit-exceeded function	
Output not active	Output active
0 V	10 V
0 mA	20 mA
4 mA	20 mA

### 7.14 Controller (Controller settings)

Pump variant	Controller (Controller settings)
NBE, NBGE, NKE, NBSE, VLSE	•
NBE, NBGE, NKE, NBSE Series 2000; VLSE with Delta p sensor	•

The pumps have a factory default setting of gain ( $K_p$ ) and integral time ( $T_i$ ).

However, if the factory setting is not the optimum setting, you can change the gain and the integral time:

- Set the gain within the range from 0.1 to 20.
- Set the integral-action time within the range from 0.1 to 3600 seconds. If you select 3600 seconds, the controller functions as a P controller.

Furthermore, you can set the controller to inverse control.

This means that if you increase the setpoint, the speed is reduced. In the case of inverse control, you must set the gain within the range from -0.1 to -20.

#### Guidelines for setting of PI controller

The tables below show the recommended controller settings:

Constant differential pressure	$K_p$	$T_i$
	0.5	0.5
	0.5	0.5
	0.5	L1 < 5 m: 0.5 L1 > 5 m: 3 L1 > 10 m: 5
	0.5	L1 < 5 m: 0.5 L1 > 5 m: 3 L1 > 10 m: 5

L1: Distance in metres between the pump and the sensor.

Constant temperature	$K_p$		$T_i$
	Heating system	Cooling system	
	0.5	-0.5	10 + 5L2
	0.5	-0.5	30 + 5L2

10) In heating systems, an increase in pump performance results in a rise in temperature at the sensor.

11) In cooling systems, an increase in pump performance results in a drop in temperature at the sensor.

L2: Distance in metres between the heat exchanger and the sensor.

Constant differential temperature	$K_p$	$T_i$
	-0.5	10 + 5L2
	-0.5	10 + 5L2

L2: Distance in metres between the heat exchanger and the sensor.

Constant flow rate	$K_p$	$T_i$
	0.5	0.5

Constant pressure	$K_p$	$T_i$
	0.5	0.5
	0.5	0.5

Constant level	$K_p$	$T_i$
	-10	0
	10	0

General rules of thumb:

If the controller is too slow-reacting, increase the gain.

If the controller is hunting or unstable, dampen the system by reducing the gain or increasing the integral time.

#### Factory setting

See the section on factory settings.

### 7.15 Operating range

Pump variant	Operating range
NBE, NBGE, NKE, NBSE, VLSE	•
NBE, NBGE, NKE, NBSE Series 2000; VLSE with Delta ρ sensor	•

Set the operating range as follows:

1. Set the minimum speed within the range from fixed minimum speed (5) to user-set maximum speed (2).
2. Set the maximum speed within the range from user-set minimum speed (4) to fixed maximum speed (1).

The range between the user-set minimum and maximum speed is the operating range (3).

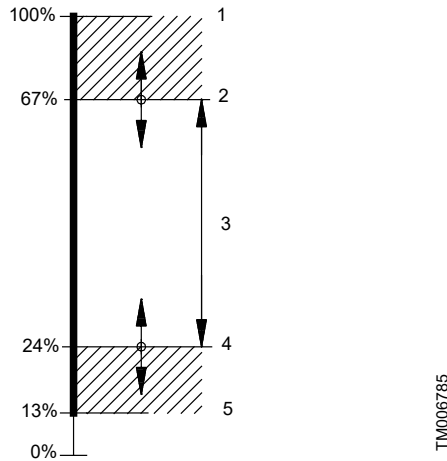

Pos.	Description
1	Fixed maximum speed
2	User-set maximum speed
3	Operating range
4	User-set minimum speed
5	Fixed minimum speed

### 7.16 External setpoint function

Pump variant	External setpoint function
NBE, NBGE, NKE, NBSE, VLSE	•
NBE, NBGE, NKE, NBSE Series 2000; VLSE with Delta ρ sensor	•

Use this function to influence the setpoint by an external signal via one of the analog inputs.

If the FM310 or FM311 functional module is fitted, you can also influence the setpoint via one of the Pt100/1000 inputs.



To enable the function, set one of the analog inputs or Pt100/1000 inputs to **Setpoint influence** with Grundfos GO or to **Ext. setpoint infl.** with the HMI 300 or 301 operating panel.

#### Example of setpoint influence in control mode Const. pressure

Actual setpoint: actual input signal × setpoint. At a setpoint of 2 bar and an external setpoint of 60 %, the actual setpoint is  $0.60 \times 2 = 1.2$  bar. At a setpoint of 232 psi and an external setpoint of 60 %, the actual setpoint is  $0.60 \times (232 - 0) + 0 = 139$  psi.

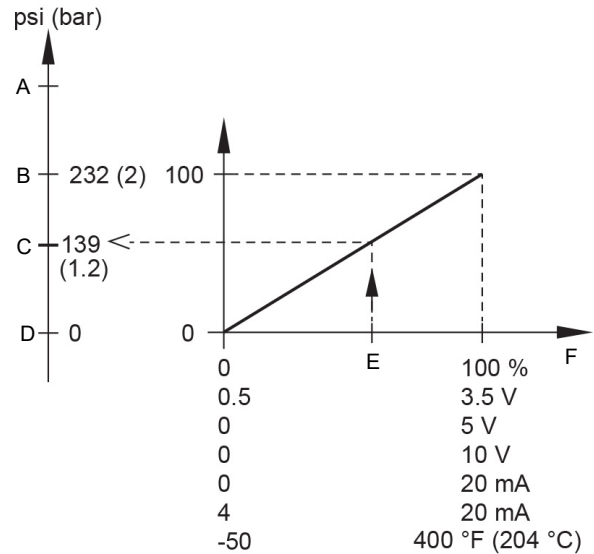

#### Example of setpoint influence with sensor feed back

Pos.	Description
X:	External input signal from 0 to 100 %
Y:	Setpoint influence from 0 to 100 %
X1:	Actual input signal, 60 %
Y1:	Sensor maximum
Y2:	Setpoint
Y3:	Actual setpoint
Y4:	Sensor minimum

#### Example of a constant curve with linear influence function

Actual setpoint: actual input signal × (setpoint - user-set minimum speed) + user-set minimum speed. At a user-set minimum speed of 25 %, a setpoint of 85 % and an external setpoint of 60 %, the actual setpoint is  $0.60 \times (85 - 25) + 25 = 61$  %.

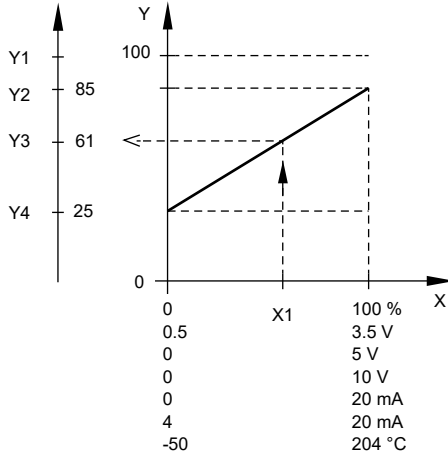

TM070253

Pos.	Description
X:	External input signal from 0 to 100 %
Y:	Setpoint influence from 0 to 100 %
X1:	Actual input signal, 60 %
Y1:	Fixed maximum speed in percentage
Y2:	Setpoint speed in percentage
Y3:	Actual setpoint speed in percentage
Y4:	User-set minimum speed in percentage

### 7.16.1 Setpoint influence functions

#### 7.16.1.1 Linear function

The setpoint is influenced linearly from 0 to 100 %.

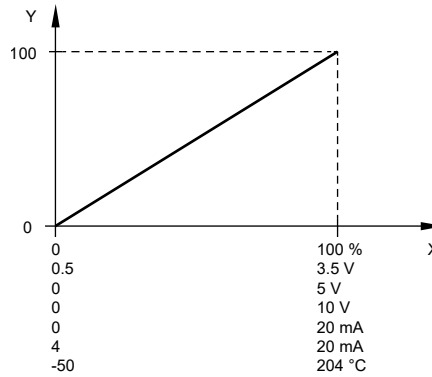

TM070255

Pos.	Description
X	External input signal from 0 to 100 %
Y	Setpoint influence from 0 to 100 %

#### 7.16.1.2 Linear with Stop

In the input signal range from 20 to 100 %, the setpoint is influenced linearly. If the input signal is below 10 %, the motor changes to the **Stop** operating mode. If the input signal increases over 15 %, the operating mode changes back to **Normal**.

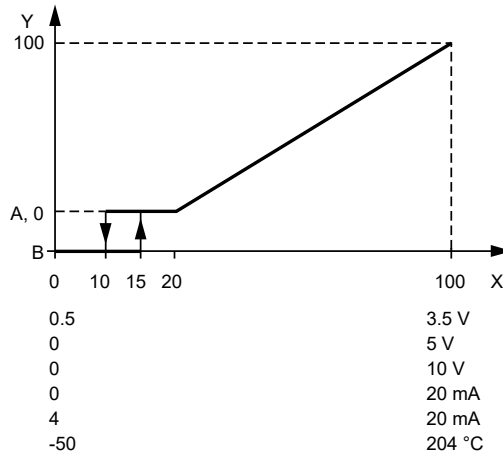

TM070542

Pos.	Description
X	External input signal from 0 to 100 %
Y	Setpoint influence from 0 to 100 %
A	<b>Normal</b>
B	<b>Stop</b>

#### 7.16.1.3 Influence table

The setpoint is influenced by a curve made of two to eight points. There is a straight line between the points and a horizontal line before the first point and after the last point.

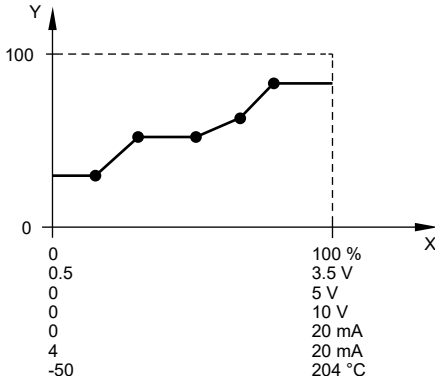

TM070254

Pos.	Description
X	External input signal from 0 to 100 %
Y	Setpoint influence from 0 to 100 %

### 7.17 Predefined setpoints

Pump variant	Predefined setpoints
NBE, NBGE, NKE, NBSE, VLSE	•
NBE, NBGE, NKE, NBSE Series 2000; VLSE with Delta $\rho$ sensor	•

You can set and activate seven predefined setpoints by combining the input signals with digital inputs 2, 3 and 4 as shown in the table below. Set the digital inputs 2, 3 and 4 to **Predefined setpoints** if all seven predefined setpoints are to be used. You can also set one or two of the digital inputs to **Predefined setpoints**. However, this limits the number of predefined setpoints available.

Digital inputs			Setpoint
2	3	4	
0	0	0	Normal setpoint or <b>Stop</b>
1	0	0	<b>Predefined setpoint 1</b>
0	1	0	<b>Predefined setpoint 2</b>
1	1	0	<b>Predefined setpoint 3</b>
0	0	1	<b>Predefined setpoint 4</b>
1	0	1	<b>Predefined setpoint 5</b>
0	1	1	<b>Predefined setpoint 6</b>
1	1	1	<b>Predefined setpoint 7</b>

0: Open contact  
1: Closed contact

#### Example

The figure shows how you can use the digital inputs to set seven predefined setpoints. Digital input 2 is open, and digital inputs 3 and 4 are closed. If you compare with the table above, you can see that **Predefined setpoint 6** is activated.

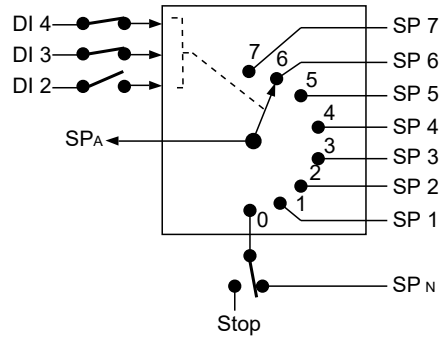

TM070083

Pos.	Description
DI	Digital input
SP	Setpoint
SP <sub>A</sub>	Actual setpoint
SP <sub>N</sub>	Normal setpoint
Stop	Stop

If all digital inputs are open, the motor stops or runs at the normal setpoint. Set the desired action with Grundfos GO or with the HMI 300 or 301 operating panel.

## 7.18 Limit-exceeded function

Pump variant	Limit-exceeded function
NBE, NBGE, NKE, NBSE, VLSE	•
NBE, NBGE, NKE, NBSE Series 2000; VLSE with Delta p sensor	•

Use this function to monitor a measured parameter or one of the internal values such as speed, motor load or motor current. If a set limit is reached, a selected action can take place. You can set up to four limit-exceeded functions, meaning that you can monitor four different parameters or two to four limits of the same parameter simultaneously.

Note that, if using **Limit 1-3 exceeded** in a multipump system, the selected action will have an impact on the system, e.g. if Action is set to Stop, then the system will stop.

**Limit 4 exceeded** in a multipump system will be a local function. The selected action will only have an impact on the single pump, e.g. if Action is set to Stop, then only the single pump will stop.



For **Limit 4 exceeded** in a multipump system, the action will always lead to a pump stop, alarm and stop or a warning.

The function requires setting of the following parameters:

### Measured

Set the measured parameter to be monitored.

### Limit

Set the limit which activates the function.

### Hysteresis band

Set the hysteresis band for when the function must be deactivated again.

### Limit exceeded when

Set the function to be activated when the selected parameter exceeds or drops below the set limit.

- **above limit**  
The function is activated if the measured parameter exceeds the set limit.
- **below limit**  
The function is activated if the measured parameter drops below the set limit.

### Action

If the value exceeds a limit, you can set an action. The following actions are available:

- **Not active**  
The pump remains in its current state. Use this setting if you only want to activate a signal relay output when the limit is reached.
- **Stop**  
The pump stops.
- **Min.**  
The pump reduces the speed to minimum speed.
- **Max.**  
The pump increases the speed to maximum speed.
- **User-defined speed**  
The pump runs at a speed set by the user.
- **Alarm and Stop**  
An alarm is given, and the pump stops.
- **Alarm and Min**

An alarm is given, and the pump decreases the speed to a minimum.

- **Alarm and Max**  
An alarm is given, and the pump increases the speed to maximum.
- **Alarm and User-defined speed**  
An alarm is given, and the pump runs at the speed set by the user.

### Alarm and Warning text

The **Limit-exceeded** function will automatically define a relevant alarm/warning text based on the **Measured parameter** and **Limit exceeded when** functions.

The auto defined text can be overwritten by selecting the alarm/warning text option **Limit X exceeded**.

The following list shows the auto defined texts:

- Limit X exceeded
- Low inlet pressure
- High discharge pressure
- High pressure
- Low pressure
- High temperature
- Low temperature
- High flow
- Low flow
- High level
- Low level
- High diff. pressure
- Low diff. pressure
- High conductivity

### Detection in Stop

Enable this function to prevent the pump from monitoring the limit while the pump is in the **Stop** state.



Use the **Detection delay** function to allow the pump to start up and bring the value above the limit before detecting.

### Detection delay

Setting the detection delay ensures that the monitored parameter stays above or below a set limit in a set time before the function is activated.

### Resetting delay

The resetting delay is the time from when the measured parameter differs from the set limit, including the set hysteresis band, and until the function is reset.

## 7.19 Ramps

Pump variant	Ramps
NBE, NBGE, NKE, NBSE, VLSE	•
NBE, NBGE, NKE, NBSE Series 2000; VLSE with Delta p sensor	•

The ramps determine how quickly the product can accelerate and decelerate during start and stop or setpoint changes.

You can make the following settings:

- acceleration time, 0.1 to 300 s
- deceleration time, 0.1 to 300 s.

The times apply to the acceleration from 0 rpm to a fixed maximum speed and the deceleration from a fixed maximum speed to 0 rpm, respectively.

At short deceleration times, the deceleration of the product may depend on load and inertia as there is no possibility of actively braking the product.

If the power supply is switched off, the deceleration of the product only depends on the load and inertia.

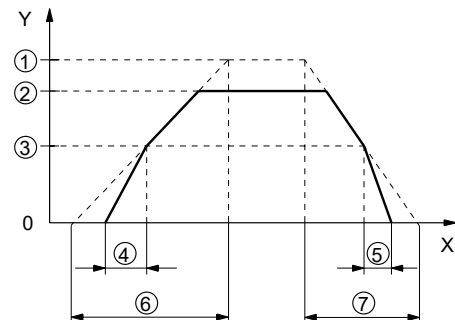

TM069798

Pos.	Description
Y	Speed
X	Time
1	Fixed maximum
2	User-set maximum
3	User-set minimum
4	Fixed initial ramp
5	Fixed final ramp
6	Ramp time up
7	Ramp time down

## 7.20 Skip band

Pump variant	Skid band
NBE, NBGE, NKE, NBSE, VLSE	•
NBE, NBGE, NKE, NBSE Series 2000; VLSE with Delta p sensor	•

Use this function to select a skip band within the range from user-set minimum speed to user-set maximum speed if continuous operation is not required. The upper and lower speeds are stated in percentage of rated speed.

The purpose of the skip band is to avoid certain speeds which may cause noise or vibrations. If no skip band is required, select -.

## 7.21 Standstill heating

Pump variant	Standstill heating
NBE, NBGE, NKE, NBSE, VLSE	•
NBE, NBGE, NKE, NBSE Series 2000; VLSE with Delta p sensor	•

Use this function to avoid condensation in humid environments.

When you set the function to **Active** and the product is in operating mode **Stop**, a low AC voltage is applied to the motor windings.

The voltage is not high enough to make the motor rotate, but ensures that sufficient heat is generated to avoid condensation in the product, including the electronic parts in the drive.



Remember to remove the drain plugs and fit a cover over the product.

## 7.22 Alarm handling

Pump variant	Alarm handling
NBE, NBGE, NKE, NBSE, VLSE	•
NBE, NBGE, NKE, NBSE Series 2000; VLSE with Delta p sensor	•

This setting determines how the pump must react in case of a sensor failure.

Alarm or warning types:

- **Warning**  
A warning. There is no change in the operating mode.
- **Stop**  
The pump stops.
- **Min.**  
The pump reduces the speed to minimum.
- **Max.**  
The pump increases the speed to maximum.
- **User defined speed**  
The pump runs at the speed set by the user.

Affected inputs:

- **Analog input 1**
- **Analog input 2**
- **Analog input 3**
- **Built-in Grundfos sensor**
- **Pt100/1000 input 1**
- **Pt100/1000 input 2**
- **Liqtec input.**

## 7.23 Motor bearing monitoring

Pump variant	Motor bearing monitoring
NBE, NBGE, NKE, NBSE, VLSE	•

Pump variant	Motor bearing monitoring
NBE, NBGE, NKE, NBSE Series 2000; VLSE with Delta p sensor	•

Use this function to select whether or not you want to monitor the motor bearings.

You can make the following settings:

- **Active**
- **Not active**

When the function is set to **Active**, a counter in the controller starts counting the running hours of the bearings. The running hours are calculated on the basis of the motor speed. When a predefined limit is reached, a warning indicates that the bearings must be replaced or relubricated.



If you change the function to **Not active**, the counter continues to count. However, no warning is given when it is time to replace the bearings. If you change the function to **Active** again, the accumulated running hours are used to recalculate the replacement time.

## 7.24 Service

Pump variant	Service
NBE, NBGE, NKE, NBSE, VLSE	•
NBE, NBGE, NKE, NBSE Series 2000; VLSE with Delta p sensor	•

### 7.24.1 Motor bearing service

This display shows when to replace the motor bearings. The controller monitors the operating pattern of the motor and calculates the period between bearing replacements.

Displayable values:

- **in 2 years**
- **in 1 year**
- **in 6 months**
- **in 3 months**
- **in 1 month**
- **in 1 week**
- **Now!**

### 7.24.2 Bearing replacements

The display shows the number of bearing replacements made during the lifetime of the motor.

### 7.24.3 Motor bearing maintenance

When the bearing monitoring function is active, a warning is given when the motor bearings must be replaced.

1. Replace the motor bearings.
2. Press **Bearings replaced**.

### 7.24.4 Bearings relubricated

When the bearing monitoring function is active, a warning is given when the motor bearings must be relubricated.



Bearings can be relubricated 5 times before they must be replaced.

The amount of grease can be found on the bearing nameplate on the motor.

1. When you have relubricated the bearings, press **Bearings relubricated**.

## 7.25 Communication

Pump variant	Communication
NBE, NBGE, NKE, NBSE, VLSE	•
NBE, NBGE, NKE, NBSE Series 2000; VLSE with Delta p sensor	•

Use this function to set the communication of the product, both wired and wireless communication. The product contains built-in fieldbus protocols on the AYB terminals (RS-485).

### 7.25.1 Pump number

Use this function to allocate a unique number to the pump. This makes it possible to distinguish between pumps in connection with GENIbus communication.

### 7.25.2 Enable/disable radio comm.

Use this function to set the radio communication to **Enabled** or **Disabled**. Select **Disabled** in areas where radio communication is not allowed.



Bluetooth communication remains active.

### 7.25.3 Enable/disable Bluetooth comm.

Use this function to set the Bluetooth communication to **Enabled** or **Disabled**. Select **Disabled** in areas where Bluetooth communication is not allowed.



Radio communication remains active.

### 7.25.4 Initiate Bluetooth connection

Use this function if Grundfos GO is installed on Huawei smartphones with BLE version 5.0 or older. This function is used to establish a Bluetooth connection to Grundfos GO. Open the Grundfos GO app on your device and select **Initiate Bluetooth connection**. Then select **Yes** and follow the instructions on the device.

### 7.25.5 Setup of AYB terminals

#### 7.25.5.1 Protocol selection

Use this function to select which fieldbus protocol that must be active on the AYB terminals (RS-485).

Select between the following:

- Modbus RTU
- GENIbus.

### 7.25.5.2 Modbus RTU settings

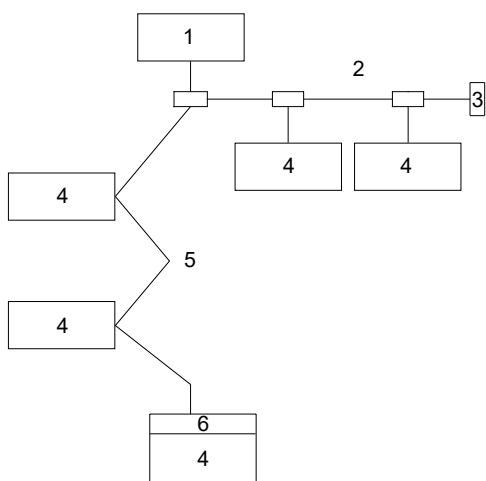

Example of Modbus network with termination

Pos.	Description
1	Master
2	Passive tap
3	Line termination
4	Slave
5	Daisy chain
6	BLT (BLT = Built-in line termination (dip switch))



Remember to set the AYB BUS termination dip switch to ON in case the pump is the first or the last pump on a daisy chain of pumps. The termination resistor has a value of 150 ohm.

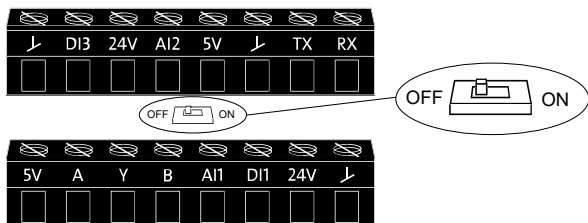

#### Modbus RTU address

Use this function to allocate a unique number to the pump. This makes it possible to distinguish between pumps in connection with Modbus RTU communication.

Select a number between 1 and 247.

#### Baud rate

Use this function to select the baud rate at which Modbus RTU is to communicate.

Select between the following baud rates:

- 9600 bps
- 19200 bps
- 38400 bps
- 115200 bps.

#### Parity

Use this function to set the parity of the Modbus RTU channel.

Select between these values:

- None

- Odd
- Even.

#### Stop bits

Use this function to set the number of stop bits on the Modbus RTU channel.

Select between these values:

- 1 bit
- 2 bits.

### 7.25.6 Setup of Ethernet



The product is equipped with an Ethernet port with a GENI GDP protocol that can be accessed from Grundfos iSOLUTION Cloud and other cloud based solutions.

Grundfos will support the product with security updates for at least 2 years from production of the unit.

#### 7.25.6.1 IP Settings

Use this function to set the Ethernet communication.

#### 7.25.6.2 DHCP

Use this function to select if DHCP should be activated or deactivated.

If activated, the E-pump will receive network configuration from the DHCP server on the network.

If deactivated, IP address, Subnet mask, Gateway and Primary DNS must be configured manually.

#### 7.25.6.3 IP address

Use this function to manually set the IP address. IP address format:

Example: 192.168.0.10

#### 7.25.6.4 Subnet mask

Use this function to manually set the subnet mask. Subnet mask format:

Example: 255.255.255.0

#### 7.25.6.5 Gateway

Use this function to manually set the gateway address. Gateway address format:

Example: 192.168.1.1

#### 7.25.6.6 Primary DNS

Use this function to manually set the primary DNS address.

Example of primary DNS address format: 8.8.8.8

#### 7.25.6.7 Secondary DNS

Use this function to manually set the secondary DNS address.

Example of secondary DNS address format: 4.4.4.4

### 7.25.7 Language

The function is only available in the HMI 300 and HMI 301 operating panels.

Use this function to select the desired language from the list.

### 7.25.8 Set date and time

The function is only available in the HMI 300 and HMI 301 operating panels.

Use this function to set the date and time as well as how you want them to be viewed on the display.

- **Select date format:**
  - YYYY-MM-DD
  - DD-MM-YYYY
  - MM-DD-YYYY.
- **Select time format:**
  - HH:MM 24-hour clock
  - HH:MM am/pm 12-hour clock.
- **Set date.**
- **Set time.**

TM083380

TM083381

## 7.25.9 Units

This function is only available in the HMI 300 and HMI 301 operating panels.

Use this function to select SI or US units. You can make the setting for all parameters or customize for each individual parameter.

### 7.25.10 Enable/disable settings

Use this function to disable the adjusting of settings for protective reasons.

- If you use Grundfos GO and set the buttons to **Not active**, the buttons on the HMI 200 or HMI 201 operating panel are disabled, except the **Radio communication** button.
- If you disable the buttons on pumps fitted with the HMI 300 or HMI 301 operating panel via **Enable/disable settings**, you can still use the buttons to navigate through the menus but you cannot make changes directly on these operating panels. A lock symbol appears on the display. However, you can unlock the motor temporarily and allow settings by pressing the **Up** and **Down** buttons simultaneously for at least 5 seconds.

### 7.25.11 Delete history

This function is only available in the HMI 300 and HMI 301 operating panels.

Use this function to delete the following historical data:

- **Delete operating log**
- **Delete energy consumption.**

### 7.25.12 Define Home display

This function is only available in the HMI 300 and HMI 301 operating panels.

Set the **Home** display to show up to four user-defined parameters.

### 7.25.13 Display settings

This function is only available in the HMI 300 or HMI 301 operating panels.

Use this function to adjust the display brightness. You can also set whether or not the display is to switch off if no buttons are activated for a period of time.

### 7.25.14 Store actual settings

Use this function to store the current settings to enable the user to go back to a previous set of settings.

### 7.25.15 Recall stored settings

#### Grundfos GO

In this menu, you can recall stored settings from a number of previously stored settings that the pump then uses.

#### Advanced operating panel

In this menu, you can recall the last stored settings that the pump then uses.

### 7.25.16 Undo

This function is only available in the Grundfos GO.

Use this function to undo all settings made with the Grundfos GO in the current communication session. Once you recall settings, you cannot undo it.

### 7.25.17 Pump name

This function is only available in the Grundfos GO.

Use this function to give the motor a name. The selected name then appears in the Grundfos GO.

### 7.25.18 Connection code

Use the connection code to enable automatic connection between Grundfos GO and the product. Thus, you do not need to press **OK** or the **Radio communication** button each time.

You can also use the connection code to restrict remote access to the product.

You can only set the connection code with Grundfos GO.

### 7.25.18.1 Setting a connection code in the product by using the Grundfos GO

1. Connect Grundfos GO to the product.
2. Go to **Settings > General > Connection code**.
3. Enter a connection code and press **OK**.

You can change the code in the **Connection code** menu at any time. The old code is not required.

### 7.25.19 Run start-up guide

The function is only available in the HMI 300 and HMI 301 operating panels.

The startup guide automatically starts when you start the product for the first time. You can always run it later. It guides you through the general settings of the product.

To run the startup guide, go to **Settings > General settings > Run start-up guide**.

### 7.25.20 Alarm log

This function contains a list of logged alarms from the product. The log shows the alarm code, name of the alarm, when the alarm occurred and when the alarm was reset.

### 7.25.21 Warning log

This function contains a list of logged warnings from the product. The log shows the warning code, name of the warning, when the warning occurred and when the warning was reset.

### 7.25.22 Assist

This menu consists of a number of different assist functions.

Assist functions are small guides that take you through the steps needed to set the product.

### 7.25.23 Assisted pump setup

This function guides you through the following:

#### Setting the motor

- Selection of control mode
- Configuration of feedback sensors
- Adjustment of the setpoint
- Controller settings
- Summary of settings.

With Grundfos GO, access the **Assisted pump setup** menu.

With the HMI 300 or 301 operating panel, access the **Assisted pump setup** menu.

### 7.25.24 Setup, analog inputs

This function is only available in the HMI 300 and HMI 301 operating panels.

- **Analog inputs**, follow on-screen instructions.
- **Pt100/1000 inputs**, follow on-screen instructions.

### 7.25.25 Setting of date and time

The function is only available in the HMI 300 and 301 operating panels.

The inputs and outputs available depend on the functional module fitted in the motor.

Functional module	Setting of date and time
FM310	•
FM311	•

The function guides you through the following settings:

- **Select date format**
- **Set date**
- **Select time format**
- **Set time.**

### 7.25.26 Multipump function

The function **Multi-pump function** enables the control of two motors connected in parallel without the use of external controllers. The pumps or motors in a system communicate with each other via the wireless GENIair connection or the wired GENI connection. You can set a multipump system via the master motor, which is the first selected motor.

If several pumps or motors in the system have sensors, they can all function as the master and take over the master function if the other fails. This provides additional redundancy in the multimotor system.

You can choose between the following multimotor functions:

#### Alternating operation

Alternating operation functions as a duty and standby operating mode and is possible with two pumps or two motors of the same size and type connected in parallel. The main purpose of the function is to ensure an even amount of running hours and to ensure that the other pump or motor starts if the duty pump or motor stops due to an alarm.

You can choose between two alternating operating modes:

- **Alternating operation, time**

The change from one pump or motor to the other is based on time.

- **Alternating operation, energy**

The change from one pump or motor to the other is based on energy consumption.

If the duty pump or motor fails, the other pump or motor starts.

#### Backup operation

Backup operation is possible with two motors of the same size and type connected in parallel. One motor is operating continuously. The backup motor is operated for a short time each day to prevent seizing up. If the duty motor stops due to a fault, the backup motor starts.

#### Cascade operation

This function is available with up to 4 motors installed in parallel. The motors must be of the same size and if used with pumps, the pumps must be of the same model.

- The performance is adjusted to the demand through cutting pumps in or out and through parallel control of the pumps in operation.
- The controller maintains a constant process value through continuous adjustment of the speed of the pumps.
- Pump changeover is automatic and depends on load, operating hours and fault detection.
- All pumps in operation run at the same speed.
- The number of pumps in operation also depends on the energy consumption of the pumps. If only one pump is required, two pumps will run at a lower speed if this results in a lower energy consumption.
- If several pumps or motors in the system have a sensor, they can all function as the master and take over the master function if the other fails.

#### 7.25.26.1 Alternating operation, time

The **Alternating operation, time** menu sets the interval of alternation between two pumps.

This setting is only available in alternating mode.

#### 7.25.26.2 Time for pump changeover

The **Time for pump changeover** menu sets the time of day for pump changeover to take place.

This setting is only available in alternating operation.

#### 7.25.26.3 Sensor to be used

This function defines the sensor for controlling the pump system.

Select **Master pump sensor** if the sensor is placed in a way where it can measure the output from all the pumps in the system, for example, in the manifold.

Select **Running pump sensor** if the sensor is placed on or across individual pumps, for example, if the sensor is installed behind non-return valves, or if it is not able to measure the output from all pumps.

This setting is only available in alternating operation and cascade operation.

#### 7.25.26.4 Setting up a multipump system

You can set up a multipump system in the following ways:

- Grundfos GO and wireless motor connection
- Grundfos GO and wired motor connection
- HMI 300 or HMI 301 operating panel and wireless motor connection
- HMI 300 or HMI 301 operating panel and wired motor connection.

#### Grundfos GO and wireless motor connection

1. Power on both motors.
2. Establish contact to one of the motors with the Grundfos GO.
3. Set the needed analog and digital inputs via the Grundfos GO, according to the connected equipment and the required functionality.
4. Assign a name to the motor using the Grundfos GO.
5. Disconnect the Grundfos GO from the motor.
6. Establish contact to the other motor.
7. Set the needed analog and digital inputs via the Grundfos GO, according to the connected equipment and the required functionality.
8. Assign a name to the motor using the Grundfos GO.
9. Select the **Assist** menu and **Setup of multi-pump system**.
10. Select the desired multimotor function.
11. Press the **Right** button to continue.
12. Set the time when the alternation between the two motors is to take place.



This step applies only if you have selected **Alternating operation, time** and if the motors are fitted with the FM310 or FM311.

13. Press the **Right** button to continue.
14. Select **Radio** as the communication method between the two motors.
15. Press the **Right** button to continue.
16. Select pump 2 (motor 2).
17. Select the pump from the list.



Use **OK** or the **Radio communication** button to identify the pump.

18. Press the **Right** button to continue.
19. Confirm the setting by pressing **Send**.
20. When you finish the setup and the dialog box disappears, wait for the green indicator light in the middle of **Grundfos Eye** to light up.

#### Grundfos GO and wired motor connection

1. Connect the two motors with each other with a 3-core screened cable between the GENIbus terminals A, Y, B.

2. Power on both motors.
3. Establish contact to one of the motors with the Grundfos GO.
4. Set the required analog and digital inputs via the Grundfos GO, according to the connected equipment and the required functionality.
5. Assign a name to the motor using the Grundfos GO.
6. Assign motor number 1 to the motor.
7. Disconnect the Grundfos GO from the motor.
8. Establish contact to the other motor.
9. Set the analog and digital inputs according to the connected equipment and the required functionality by the Grundfos GO.
10. Assign a name to the motor using the Grundfos GO.
11. Assign motor number 2 to the motor.
12. Select the **Assist** menu and **Setup of multi-pump system (multimotor setup)**.
13. Select the desired multimotor function.
14. Press the **Right** button to continue.
15. Set the time when the alternation between the two motors is to take place.



This step applies only if you have selected **Alternating operation, time** and if the motors are fitted with the FM310 or FM311.

16. Press the **Right** button to continue.
17. Select **Bus** as the communication method between the two motors.
18. Press the **Right** button to continue.
19. Select pump 2 (motor 2).
20. Select the additional motor from the list.



Use **OK** or the **Radio communication** button to identify the pump.

21. Press the **Right** button to continue.
22. Confirm the setting by pressing **Send**.
23. When you have finish the setup and the dialog box disappears, wait for the green indicator light in the middle of the **Grundfos Eye** to light up.

#### HMI 300 or HMI 301 and wireless motor connection

1. Power on both motors.
2. On both motors, set the analog and digital inputs according to the connected equipment and the required functionality.
3. Select the **Assist** menu on one of the motors and **Setup of multi-pump system**.
4. Press the **Right** button to continue.
5. Select **Wireless** as the communication method between the two motors.
6. Press the **Right** button to continue.
7. Select the desired multimotor function.
8. Press the **Right** button three times to continue.
9. Press **OK** to search for other motors.  
The green indicator light in the middle of the **Grundfos Eye** flashes on the other motors.

10. Press **OK** or the **Radio communication** button on the motor that is to be added to the multimotor system.
11. Press the **Right** button to continue.
12. Set the **Time for pump changeover**.  
This is the time when the alternation between the two motors is to take place.



This step applies only if you have selected **Alternating operation, time** and if the motors are fitted with the FM310 or FM311.

13. Press the **Right** button to continue.
14. Press **OK** to confirm the setting.  
The multipump function icons appear at the bottom of the operating panels.

#### HMI 300 or HMI 301 and wired motor connection

1. Connect the two motors with each other with a 3-core screened cable between the GENIbus terminals A, Y, B.
2. Set the needed analog and digital inputs according to the connected equipment and the required functionality.
3. Assign motor number 1 to the first motor.
4. Assign motor number 2 to the other motor.
5. Select the **Assist** menu on one of the motors and the **Setup of multi-pump system**.
6. Press the **Right** button to continue.
7. Select **Wired GENIbus** as the communication method between the two motors.
8. Press the **Right** button twice to continue.
9. Select the desired multimotor function.
10. Press the **Right** button to continue.
11. Press **OK** to search for other motors.
12. Select the additional motor from the list.
13. Press the **Right** button to continue.
14. Set the **Time for pump changeover**.  
This is the time when the alternation between the two motors is to take place.



This step applies only if you have selected **Alternating operation, time** and if the motors are fitted with the FM310 or FM311.

15. Press the **Right** button to continue.
16. Press **OK** to confirm the setting.  
The multipump function icons appear at the bottom of the operating panels.

#### 7.25.26.5 Grundfos GO

1. Go to **Assist**.
2. Select the **Multi-pump setup** and press **Disable**.
3. Press the **Right** button to continue.
4. Confirm the setting by pressing **Send**.
5. Press **Finish**.

#### 7.25.26.6 HMI 300 or HMI 301

1. Go to **Assist**.
2. Select the **Setup of multi-pump system**.
3. Press the **Right** button to continue.
4. Press **OK** to confirm **Disable**.
5. Press the **Right** button to continue.
6. Press **OK** to confirm.

#### 7.25.27 Description of control mode

This function is only available in the HMI 300 and HMI 301 operating panels.

The function describes each of the control modes available for the product.

#### 7.25.28 Assisted fault advice

This function provides guidance and corrective actions in the event of product failure.

### 7.25.29 Priority of settings

With Grundfos GO, you can set the motor to operate at maximum speed or to stop.

If two or more functions are enabled at the same time, the motor operates according to the function with the highest priority.

If you have set the motor to maximum speed via the digital input, the motor operating panel or Grundfos GO can only set the motor to **Manual** or **Stop**.

The priority of the settings appears from the table below:

Priority	Start/stop button	Grundfos GO or operating panel on motor	Digital input	Bus communication
1	<b>Stop</b>			
2		<b>Stop</b> <sup>12)</sup>		
3		<b>Manual</b>		
4		<b>Maximum speed / User defined speed</b> <sup>12)</sup>		
5			<b>Stop</b>	
6			<b>User defined speed</b>	
7				<b>Stop</b>
8				<b>Maximum speed / User defined speed</b>
9				<b>Minimum speed</b>
10				<b>Start</b>
11			<b>Maximum speed</b>	
12		<b>Minimum speed</b>		
13			<b>Minimum speed</b>	
14			<b>Start</b>	
15		<b>Start</b>		

<sup>12)</sup> **Stop** and **Maximum speed** settings made with Grundfos GO or on the motor operating panel can be overruled by another operating-mode command sent from a bus, for example **Start**. If the bus communication is interrupted, the motor resumes its previous operating mode, for example **Stop**, that was selected with Grundfos GO or the motor operating panel.

## 7.25.30 Factory settings

- Function is enabled.
- Function is disabled.
- Function is not available.

Settings	NBE, NBGE, NKE, NBSE, VLSE	NBE, NBGE, NKE, NBSE Series 2000; VLSE with Delta $\rho$ sensor
Setpoint	67 %	58 %
Operating mode	Normal	Normal
Control mode	Const. curve	Prop. pressure
Date and time	•	•
Buttons on product	•	•
<b>Controller (Controller settings)</b>		
$T_i$	0.5	0.5
$K_p$	0.5	0.5
<b>Operating range</b>		
Min.	25 %	25 %
Max.	110 %	110 %
<b>Ramps</b>		
Ramp-up	○	○
Ramp-down	1 second	1 second
Ramp-down	3 seconds	3 seconds
Number (Pump number)	1	1
Radio communication	•	•
Analog input 1	○	○ <sup>13)</sup>
Analog input 2	○	○
Analog input 3	○	○
Grundfos Direct Sensor	-	• <sup>14)</sup>
Pt100/1000 input 1	○	○
Pt100/1000 input 2	○	○
Digital input 1	Ext. stop	Ext. stop
Digital input 2	○	○
Digital input 3	○	○
Digital input/output 4	○	○
Predefined setpoints	○	○
Analog output	○	○
External setpoint funct.	○	○
Signal relay 1	Alarm	Alarm
Signal relay 2	Ready	Ready
Limit 1 exceeded	○	○
Limit 2 exceeded	○	○
Limit 3 exceeded	○	○
Limit 4 exceeded	○	○
Standstill heating	○	○
Motor bearing monitoring	○	○

<sup>13)</sup> VLSE with Delta  $\rho$  sensor has the sensor connected to an analog input.

<sup>14)</sup> Not VLSE with Delta  $\rho$  sensor.

## 8. Safe Torque Off (STO) function

The Safe Torque Off (STO) is a safety function to stop the motor from turning without actively braking it. It follows the definition by EN61800-5-2.

For instructions on how to activate and operate the Safe Torque Off (STO) function, read the following installation and operating instructions.



### Safe Torque Off

#### Installation and operating instructions

<http://net.grundfos.com/qr/li/92916582>

### 8.1 Identification of the Safe Torque Off (STO) function

The version of the Safe Torque Off (STO) function is marked on the nameplate, after the product version number.

The Safe Torque Off (STO) functionality is only available for MGE, MLE motors having an STO version number.

The Safe Torque Off (STO) version number is shown below as **Szz**, where **zz** marks the version. For product without STO the **zz** segment will be blank.

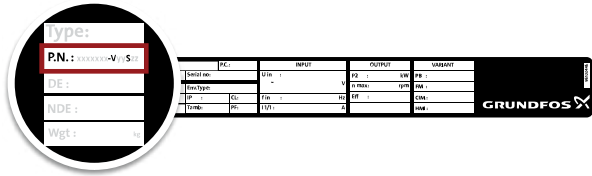

The Safe Torque Off (STO) safety function cannot be retrofitted to older motors.

QR92916582

TM084339

## 9. Servicing the product



The product must only be serviced by qualified service persons.

### WARNING

#### Rotating parts

Death or serious personal injury



- All service and maintenance related work on the product must be carried out by qualified service persons.
- Stay clear of the product after switching on power, as the shaft can rotate immediately.
- Make sure to install a protective cover before powering on the product.

### WARNING

#### Electric shock

Death or serious personal injury



- Switch off the power supply to the product including the power supply for the signal relays. Wait at least 5 minutes before you make any connections in the terminal box. Make sure that the power supply cannot be switched on accidentally.
- Tighten the cable glands to the recommended torques.
- For measuring mains voltage, use the measuring points accessible through the holes on the cover for mains cables.
- Follow the instructions in the service instructions for the motor. If parts are damaged, order new service kits.
- Connect the product to protective earth and provide protection against indirect contact in accordance with local regulations.



For recommended torques, see the section on technical data.

### WARNING

#### Magnetic field

Death or serious personal injury



- Do not handle the motor or rotor if you have a pacemaker.

### WARNING

#### Crushing of hands

Death or serious personal injury



- Follow the instructions in the service instructions for the motor.
- Wear protective gloves when servicing the product.
- Be careful when handling magnetised parts to avoid personal injury.

### WARNING

#### Falling objects

Death or serious personal injury



- Follow the lifting instructions for the product.
- Use lifting equipment rated for the weight of the product.



For lifting instructions, see the service instructions provided with the product.

**WARNING****Back injury**

Death or serious personal injury

- Use lifting equipment and follow local regulations when lifting the product.

**WARNING****Crushing of feet**

Death or serious personal injury



- Wear safety shoes.
- When lifting the motor, attach lifting equipment to the eye bolts fitted to the motor.
- **Model K:** When lifting the terminal box, attach lifting equipment to the eye bolts or lifting brackets fitted to the terminal box.

**WARNING****Hot surface**

Death or serious personal injury



- Do not touch the product while it is running. Allow surfaces to cool before servicing.

**WARNING****Cutting of hands**

Death or serious personal injury



- Do not start up and run the motor if there is no pump connected to it.

**CAUTION****Sharp element**

Minor or moderate personal injury



- When servicing the product, wear protective gloves to avoid cutting your hands on sharp edges.

**CAUTION****Cold surface**

Minor or moderate personal injury



- Make sure that no one can accidentally come into contact with cold surfaces. Wear protective gloves.

If service of the product is required, contact Grundfos.



Do not remove the rotor from the motor.

**9.1 Cleaning the product****WARNING****Electric shock**

Death or serious personal injury



- Switch off the power supply to the product including the power supply for the signal relays. Make sure that the power supply cannot be switched on accidentally.
- Check that the terminal box cover is intact before spraying water or chemicals on the product.
- Cleaning must be done with non-aggressive materials to avoid damage to surfaces and labels.
- Make sure that the air inlets are kept clean and free of residuals.



Do not expose the product to high-pressure water jets.

To clean the motor, follow the procedure below:

1. Let the motor cool down first to avoid condensation.

## 10. Taking the product out of operation

### WARNING

#### Electric shock

Death or serious personal injury



- Switch off the power supply and make sure that it cannot be accidentally switched on.
- The power supply must be switched off for at least five minutes before you start working on the product.

### WARNING

#### Back injury

Death or serious personal injury



- Use lifting equipment and follow local regulations when lifting the product.



The lifting eyes on the motor can be used for lifting the pump as well.

## 11. Technical data

### 11.1 Technical data, three-phase motors

### WARNING

#### Electric shock

Death or serious personal injury

- Use the recommended fuse size.

#### Supply voltage

- 3 × 440-480 V -10 % / +10 %, 60 Hz, PE
- 3 × 200-240 V -10 % / +10 %, 60 Hz, PE

Check that the supply voltage and frequency correspond to the values stated on the nameplate.

#### Recommended size of fuse

For recommended size of fuses see the tables below.

#### 3 × 440-480 V, Model J

Motor size [HP]	Recommended [A]	Maximum [A]
5	13	16
7 1/2	16	32
10	20	32
15	32	32

#### 3 × 440-480 V, Model K

Motor size [HP]	Recommended [A]	Maximum [A]	Fuse type
20	50	80	gG
25	60	80	gG
30	70	80	gG

#### 3 × 200-240 V, Model J

Motor size [HP]	Recommended [A]	Maximum [A]
3	13	35
5	25	35
7 1/2	32	35

#### 3 × 200-240 V, Model K

Motor size [HP]	Recommended [A]	Maximum [A]	Fuse type
10	70	80	gG
15	80	80	gG



For recommended size of fuses see the appendix concerning installation in the USA and Canada.

### 11.1.1 Leakage current (AC)

The leakage currents are measured without any load on the shaft and in accordance with EN 61800-5-1:2007.

## WARNING

### Electric shock

Death or serious personal injury



- If the leakage current is greater than 3.5 mA, use a PE cable with a minimum cross-section of at least 8 AWG (10 mm<sup>2</sup>), or use 2 separate PE cables with the same cross section as the power cable.

#### 3 × 440-480 V, 60 Hz, Model J

Speed [rpm]	Power [HP]	Power supply voltage [V]	Leakage current (I <sub>L</sub> ) [mA]
2900-4000	5 - 7 1/2	≤ 400	< 3.5
		> 400	< 3.5
	10 - 15	≤ 400	< 3.5
		> 400	3.5 < I <sub>L</sub> < 5.0
4000-5900	5 - 7 1/2	≤ 400	< 3.5
		> 400	< 3.5
	10 - 15	≤ 400	< 3.5
		> 400	3.5 < I <sub>L</sub> < 5.0

#### 3 × 440-480 V, 60 Hz, Model K

Speed [rpm]	Power [HP]	Power supply voltage [V]	Leakage current (I <sub>L</sub> ) [mA]
2900-4000	20 - 30	≤ 400	3.5 < I <sub>L</sub> < 20
		> 400	3.5 < I <sub>L</sub> < 30

#### 3 × 200-240 V, 60 Hz, Model J

Speed [rpm]	Power [HP]	Power supply voltage [V]	Leakage current (I <sub>L</sub> ) [mA]
3400-4000	3 - 7 1/2	200-240	< 3.5

#### 3 × 200-240 V, 60 Hz, Model K

Speed [rpm]	Power [HP]	Power supply voltage [V]	Leakage current (I <sub>L</sub> ) [mA]
3400-4000	10 - 15	> 200	3.5 < I <sub>L</sub> < 20

## 11.2 Inputs and outputs

### Signal reference

All voltages refer to signal ground (GND). All currents return to signal ground.

### Absolute maximum voltage and current limits

Exceeding the following electrical limits may result in severely reduced operating reliability and motor life.

Relay 1:

- Maximum contact load: 250 VAC, 2 A or 30 VDC, 2 A.

Relay 2:

- Maximum contact load: 30 VDC, 2 A.

GENI terminals: -5.5 to +9.0 VDC or less than 25 mADC.

Other input and output terminals: -0.5 to +26 VDC or less than 15 mADC.

### Digital inputs

Internal pull-up current greater than 10 mA at V<sub>i</sub> equal to 0 VDC.

Internal pull-up to 5 VDC. Currentless for V<sub>i</sub> greater than 5 VDC.

Input activated level: V<sub>i</sub> less than 1.5 VDC.

Input deactivated level: V<sub>i</sub> from 3.0 VDC to 24 VDC.

Hysteresis: No.

Screened cable: 0.5 - 1.5 mm<sup>2</sup> / 28-16 AWG.

Maximum cable length: 1640 ft (500 m).

### Safe Torque Off (STO) terminals

S24:

24 V output voltage. Only for use with ST1 and ST2 inputs.

- Output voltage: 24 V -5 % to +5 %
- Maximum current: 50 mADC
- Overload protection: Yes.

ST1 and ST2:

- STO activated: V<sub>in</sub> lower than 1.25 V
- STO deactivated: V<sub>in</sub> greater than 21.6 V and lower than 25 V
- Input current greater than 10 mA at V<sub>in</sub> equal to 24 V.

When the internal voltage source (connection S24) is used, the input voltage for ST1 and ST2 is within accepted limits.

When an external voltage source is used to drive the STO inputs, the following conditions must be met:

In operational state, the input voltage of ST1 and ST2 with reference to GND must be within:

- $V_{\min}$ : 21.6 V
- $V_{\max}$ : 25.0 V.

In the safe state, the input voltage of ST1 and ST2 with reference to GND must be as follows:

- $V_{\max}$ : 1.25 V.

In the operating state, the current flow into ST1 and ST2 must be within:

- Minimum contact current: 10 mA
- Maximum contact current: 25 mA.

Input source rating: SELV

#### Bus input (Ethernet)

Protocols TC/IP GENI, GDP.

Cable type, Standard CAT5, CAT5e or CAT6.

#### Open-collector digital outputs (OC)

Current-sinking capability: 75 mADC, no current sourcing.

Load types: Resistive and/or inductive.

Low-state output voltage at 75 mADC: Maximum 1.2 VDC.

Low-state output voltage at 10 mADC: Maximum 0.6 VDC.

Overcurrent protection: Yes.

Screened cable: 0.5 - 1.5 mm<sup>2</sup> / 28-16 AWG.

Maximum cable length: 1640 ft (500 m).

#### Analog inputs (AI)

Voltage signal ranges:

- 0.5 - 3.5 VDC, AL AU
- 0-5 VDC, AU
- 0-10 VDC, AU.

Voltage signal:

- $R_i$  greater than 100 k $\Omega$  at 77 °F (25 °C).

Leak currents may occur at high operating temperatures. Keep the source impedance low.

Current signal ranges:

- 0-20 mADC, AU
- 4-20 mADC, AL AU.

Current signal:  $R_i$  is equal to 292  $\Omega$ .

Current overload protection: Yes. Change to voltage signal.

Measurement tolerance: +/- 2 % of full scale.

Screened cable: 0.5 - 1.5 mm<sup>2</sup> / 28-16 AWG.

Maximum cable length: 1640 ft (500 m), excluding potentiometer.

Potentiometer connected to +5 V, GND, any AI: Use maximum 10 k $\Omega$ .

Maximum cable length: 328 ft (100 m).

#### Analog output (AO)

Current sourcing capability only.

Voltage signal:

- Range: 0-10 VDC
- Minimum load between AO and GND: 1 k $\Omega$
- Short-circuit protection: Yes.

Current signal:

- Ranges: 0-20 and 4-20 mADC
- Maximum load between AO and GND: 500  $\Omega$
- Open-circuit protection: Yes.

Tolerance: +/- 4 % of full scale.

Screened cable: 0.5 - 1.5 mm<sup>2</sup> / 28-16 AWG.

Maximum cable length: 1640 ft (500 m).

#### Pt100 or Pt1000 inputs (Pt)

Temperature range:

- Minimum -58 °F (-50 °C) (80  $\Omega$ /803  $\Omega$ ).
- Maximum 399 °F (204 °C) (177  $\Omega$ /1773  $\Omega$ ).

Measurement tolerance: +/- 2.7 °F (1.5 °C).

Measurement resolution: less than 0.54 °F (0.3 °C).

Automatic range detection (Pt100 or Pt1000): Yes.

Sensor fault alarm: Yes.

Screened cable: 0.5 - 1.5 mm<sup>2</sup> / 28-16 AWG.

Use Pt100 for short wires.

Use Pt1000 for long wires.

#### LiqTec sensor inputs

Use a Grundfos LiqTec sensor only.

Screened cable: 0.5 - 1.5 mm<sup>2</sup> / 28-16 AWG.

#### Grundfos Digital Sensor input and output (GDS)

Use Grundfos Digital Sensor only.

#### Power supplies, +5 V, +24 V

##### +5 V

- Output voltage: 5 VDC -5 % to +5 %
- Maximum current: 60 mADC, sourcing only
- Overload protection: Yes.

##### +24 V

- Output voltage: 24 VDC -5 % to +5 %
- Maximum current: 200 mADC, sourcing only
- Overload protection: Yes.

#### Digital outputs, relays

Potential-free changeover contacts.

Minimum contact load when in use: 5 VDC, 10 mA.

Screened cable: 0.5 - 2.5 mm<sup>2</sup> / 28-12 AWG.

Maximum cable length: 1640 ft (500 m).

#### Bus input

Grundfos GENIbus protocol, RS-485.

Grundfos Modbus protocol, RS-485.

Screened 3-core cable: 0.5 - 1.5 mm<sup>2</sup> / 28-16 AWG.

Maximum cable length: 1640 ft (500 m).

### 11.3 Other technical data

#### 11.3.1 Ecodesign Directive

This product is out of scope of Directive 2009/125/EC and Commission Regulation (EU) 2019/1781 due to Article 2 (3a), as the variable speed drive (VSD) is integrated into a product and its energy performance cannot be tested independently from the product.

#### 11.3.2 EMC (electromagnetic compatibility)

Standard used: EN 61800-3.

The table below shows the emission category of the motor.

C1 fulfils the requirements for residential areas.

C2 fulfils the requirements for residential areas if the system is operated and installed by qualified persons.

C3 fulfils the requirements for industrial areas.



In a residential environment, this product may cause radio interference in which case supplementary mitigation measures may be required.



**Model J:** When connected to a public network, 15 hp motors do not comply with the partial weighted harmonics (PWH) requirements of EN 61000-3-12. If required by the distribution network operator, compliance can be obtained in the following way:

The impedance of the power cables between the motor and the point of common coupling (PCC) must be equivalent to the impedance of a 164 ft (50 m) cable.

**Model K:** This equipment complies with IEC 61000-3-12 provided that the short-circuit power  $S_{SC}$  is greater than or equal to the respective value described in the table below at the interface point between the user's supply and the public system. It is the responsibility of the installer or user of the equipment to ensure, by consultation with the distribution network operator if necessary, that the equipment is connected only to a supply with a short-circuit power  $S_{SC}$  greater than or equal to the respective value described in the table below.



When connected to a public network, 15-25 hp motors do not comply with the partial weighted harmonics (PWH) requirements of EN 61000-3-12. If required by the distribution network operator, compliance can be obtained in the following way:

The impedance of the mains cables between the motor and the point of common coupling (PCC) must be equivalent to the impedance of a 164 ft (50 m) cable.

### 3 × 440-480 V, 60 Hz, Model K

Speed [rpm]	Power P2 [hp]	Short-circuit power [MVA]
3500-4000	20	4.6
	25	5.8
	30	6.6

### Model H, I

Speed [rpm]	Power P2 [hp]	Emission category
1750-2200	1 - 2	C1
3400-4000	1.5 - 2	
3500-4000/ 4000-5900	0.33 - 3	

### Model J

Speed [rpm]	Power P2 [hp]	Emission category
3500-4000/ 4000-5900	3 - 7 1/2	C1
	10 - 15	C3/C2 <sup>15)</sup>

<sup>15)</sup> C2, if equipped with an external Grundfos EMC filter.

### Model K

Speed [rpm]	Power P2 [hp]	Emission category
3400-4000	10 - 15	C2/C3 <sup>16)</sup>
3500-4000	20 - 30	

<sup>16)</sup> Depending on product hardware configuration.

Immunity: The motor fulfils the requirements for industrial areas. Contact Grundfos for further information.

### 11.3.3 Enclosure class

#### Motor

Standard: TEFC

#### Variable Frequency Drive

The enclosure of MLE Model H, I and J motors is approved for NEMA type 2.

The enclosure of MLE Model K motors is approved for NEMA type 12.

The NEMA rating can be found on the product nameplate:

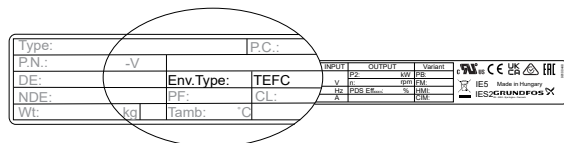

TM084777

### 11.3.4 Insulation class

311 °F (155 °C).

### 11.3.5 Standby power consumption

5-10 W.

### 11.3.6 Cable entry sizes

#### Model J

##### Number and size of cable entries

Motor [hp]	Supply voltage	Number and size of cable entries
3	3 x 200-240 V, 60 Hz	5 x 1/2" NPT
5	3 x 200-240 V, 60 Hz	5 x 1/2" NPT
	3 x 440-480 V, 60 Hz	5 x 1/2" NPT
7 1/2	3 x 200-240 V, 60 Hz	1 x 3/4" NPT & 5 x 1/2" NPT
	3 x 440-480 V, 60 Hz	5 x 1/2" NPT
10	3 x 440-480 V, 60 Hz	1 x 3/4" NPT & 5 x 1/2" NPT
15	3 x 440-480 V, 60 Hz	1 x 3/4" NPT & 5 x 1/2" NPT

#### Model K

##### Number and size of cable entries

Motor [hp]	Supply voltage	Number and size of cable entries
10-15	3 x 200-240 V, 60 Hz	1 x NPT 1" 6 x NPT 1/2"
20-30	3 x 440-480 V, 60 Hz	1 x NPT 1" 6 x NPT 1/2"

### 11.3.7 Torques

#### Torques for terminals

Terminal	Recommended torque [ft·lb]
L1, L2, L3	1.6
PE	4.4
NC, C1, C2, NO	0.4
DI1, DI2, DI3, DI4, AI1, AI2, AI3, AO1, PT1, PT2, LT1, LT2, GND, 24V, 5V, TX, RX, A, Y, B, S24, ST1, ST2	0.4

### Torques for other parts

Part designation	Recommended torque [ft·lb]
Control box, upper part	4.8 - 5.2
Cover for power supply	0.7 - 1
Blind plugs:	
M20	0.7 - 1.1
1/2" NPT	5.9 - 7.4

## 11.3.8 Sound pressure level

CA: Niveau de pression sonore      MX: Nivel de presión sonora

## Model H

Power P2 [hp]	Rated max. speed [rpm]	Speed [rpm]	Sound pressure level		
			ISO 3743		
			[dB(A)]		
		1 x 200-240 V			
0.33 - 1	4000	3000	50		
		4000	60		
	5900	4000	58		
		5900	68		
	1.5	4000	3000	50	
			4000	60	
5900		4000	58		
		5900	68		
1.2	4000	3000	57		
		4000	64		
	5900	4000	58		
		5900	68		

## Model I

Power P2 [hp]	Rated max. speed [rpm]	Speed [rpm]	Sound pressure level	
			ISO 3743	
			[dB(A)]	
		3 x 200-240 V    3 x 440-480 V		
1	2000	1500	-	37
		2000	-	43
0.33 - 1	4000	3000	-	50
		4000	-	60

Power P2 [hp]	Rated max. speed [rpm]	Speed [rpm]	Sound pressure level	
			ISO 3743	
			[dB(A)]	
		3 x 200-240 V    3 x 440-480 V		
1.5	5900	4000	-	58
		5900	-	68
	2000	1500	-	37
		2000	-	43
	4000	3000	50	50
		4000	57	60
2	5900	4000	-	58
		5900	-	68
	2000	1500	-	42
		2000	-	47
	4000	3000	50	57
		4000	57	64
3	5900	4000	-	58
		5900	-	68
	4000	3000	-	57
		4000	-	64
	5900	4000	-	58
		5900	-	68

## Model J

Power P2 [hp]	Rated max. speed [rpm]	Speed [rpm]	Sound pressure level		
			ISO 3745		
			[dB(A)]		
		3 x 200-240 V    3 x 440-480 V			
3	2200	1500	-	48	
		2200	-	57.5	
	4000	3000	57	-	
		4000	64	-	
	5	2200	1500	-	48
			2200	-	57.5
4000		3000	61	61	
		4000	68	69	
5900		4000	-	64	
		5900	-	74	
7.5	2200	1500	-	58	
		2200	-	62.5	
	4000	3000	64	61	
		4000	72	69	
	5900	4000	-	64	
		5900	-	74	

Power P2 [hp]	Rated max. speed [rpm]	Speed [rpm]	Sound pressure level ISO 3745 [dB(A)]	
			3 × 200-240 V	3 × 440-480 V
10	2200	1500	-	58
		2200	-	62.5
	4000	3000	-	66
		4000	-	73
	5900	4000	-	69
5900		-	79	
15	4000	3000	-	66
		4000	-	73
	5900	4000	-	69
		5900	-	79

**Model K**

Power P2 [hp]	Rated max. speed [rpm]	Speed [rpm]	Sound pressure level ISO 3745 [dB(A)]	
			3 × 200-240 V	3 × 440-480 V
10	4000	3400	72	-
		4000	76	-
15	4000	3000	-	66
		4000	-	73
		3400	72	-
		4000	76	-
	5900	4000	-	69
		5900	-	79
20	2200	1750	-	63
		2200	-	67.5
	4000	3500	-	72
		4000	-	76
25	2200	1750	-	65.5
		2200	-	76.5
	4000	3500	-	72
		4000	-	74
30	2200	1750	-	66
		2200	-	79.5
	4000	3500	-	72
		4000	-	74.5

## 11.4 Operating conditions

### 11.4.1 Maximum number of starts and stops

The number of starts and stops via the power supply must not exceed ten times per hour.



When switched on via the power supply, the product starts after approximately 5 seconds.

If a higher number of start and stops are required, use a digital input for external start and stop when starting and stopping the product or use the Safe Torque Off (STO) function.



When started via an external on and off switch, the product starts immediately.

### 11.4.2 Ambient temperature

#### 11.4.2.1 Ambient temperature during storage and transportation

Description	Temperature [°F] (°C)
Minimum	-22 (-30)
Maximum	140 (60)

#### 11.4.2.2 Ambient temperature during operation

##### Model J

Description	3 × 200–240 V	3 × 440–480 V <sup>17)</sup>
Minimum	-4 °F (-20 °C)	-4 °F (-20 °C)
Maximum	104 °F (40 °C)	122 °F (50 °C)

<sup>17)</sup> Continuous operation at higher temperatures reduces the expected product lifetime. If the motor operates at ambient temperatures between 122 and 140 °F (50 and 60 °C), select an oversized motor. Contact Grundfos for further information.

##### Model K

Description	3 x 200-240 V	3 x 440-480 V <sup>18)</sup>
Minimum	-4 °F (-20 °C)	-4 °F (-20 °C)
Maximum	104 °F (40 °C)	122 °F (50 °C)

<sup>18)</sup> 35 HP MLE motors are rated for a maximum value of 104 °F (40 °C).

### 11.4.3 Installation altitude

The installation altitude is the height above sea level of the installation site.

Products installed up to 3280 ft (1000 m) above sea level can be loaded 100 %.

- **Model H, I:** The product is not suitable for use on corner earthed grids in installations more than 2000 m above sea level.
- **Model J:** The product is not suitable for use on corner earthed grids in installations more than 2000 m above sea level.
- **Model K:** The product is not suitable for use on corner earthed grids.  
The motors can be installed up to 11480 ft (3500 m) above sea level.



Products installed more than 3280 ft (1000 m) above sea level must not be fully loaded due to the low density and consequent low cooling effect of the air.

The motor output power (P2) in relation to the altitude above sea level is shown in the graph.

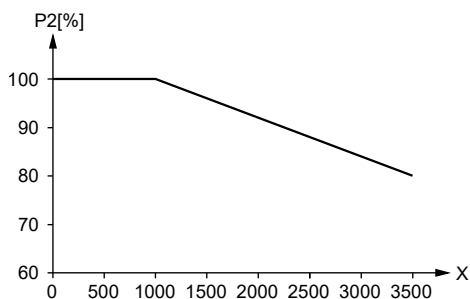

TM085127

Pos.	Description
P2	Motor output power [%]
X	Altitude [m]

### 11.4.4 Humidity

Description	Percentage
Maximum humidity (non-condensing)	95 %

If the humidity is constantly high and above 85 %, open the drain holes in the drive-end flange to vent the motor.



If you install the motor in moist surroundings or areas with high humidity, ensure that the bottom drain hole is open. As a result, the motor becomes self-venting, allowing water and humid air to escape. When you open the drain hole, the enclosure class of the motor will be lower than standard.

### 11.4.5 Pollution degree

The product is approved for Pollution degree 3 rating.

### 11.4.6 Turbine operation



Do not force the product to run at a higher speed than the maximum speed stated on the nameplate.

### 11.4.7 Accessories

Protocol	Communication interface module
LonWorks (Single)	CIM 100
LonWorks (Multi)	CIM 110
PROFIBUS DP	CIM 150
Modbus RTU	CIM 200
US GiC/GRM 3G/4G	CIM 280
BACnet MS/TP	CIM 300
Modbus TCP/IP, BACnet IP, PROFINET, GiC/GRM IP, EtherNet IP	CIM 500

## 11.4.8 Applicable standards

Standard
UL 61800-5-1, Adjustable Speed Electrical Power Drive Systems - Part 5-1: Safety Requirements - Electrical, Thermal and Energy, Edition 1, Revision Date 02/11/2021 <sup>19)</sup>
CSA C22.2 No. 274, Adjustable Speed Drives, Edition 2, Issue Date 04/2017 <sup>19)</sup>
EN/IEC 61800-5-1, Adjustable Speed Electrical Power Drive Systems - Part 5-1: Safety Requirements - Electrical, Thermal and Energy, IEC 61800-5-1:2007+AMD1:2016
UL 60730-1, Automatic Electrical Controls - Part 1: General Requirements, Edition 5, Revision Date 10/18/2021
CAN/CSA E 60730-1, Automatic Electrical Controls - Part 1: General Requirements, Edition 5, AMD 2, Revision Date 10/2021
UL 1004-1, Rotating Electrical Machines - General Requirements, Edition 2, Revision Date 11/05/2020
UL 1004-3, Thermally Protected Motors, Edition 2, Revision Date 01/31/2018
UL 1004-7, Electronically Protected Motors, Edition 3, Issue Date 06/21/2018
CSA C22.2 No. 100, Motors and Generators, Edition 7, Revision Date 04/2017
CSA C22.2 No. 77, Motors with Inherent Overheating Protection, Edition 8, Revision Date 02/2015
EN/IEC 60034-1, Rotating Electrical Machines - Part 1: Rating and Performance, Edition 14, Issue Date 02/2022
EN 18031-1:2024, Common security requirements for radio equipment - Part 1: Internet connected radio equipment, Issue Date 08/14/2024

<sup>19)</sup> Only applicable for Model K.

## 12. Disposing of the product

### DANGER

#### Magnetic field

Death or serious personal injury



- Do not dismantle, assemble or maintain the motor if you have a pacemaker or any other implanted electronic device.
- Keep the working environment clean, make sure no magnetized dust exist.

This product or parts of it must be disposed of in an environmentally sound way.

1. Use the public or private waste collection service.
2. If this is not possible, contact the nearest Grundfos company or service workshop.



The crossed-out wheeled bin symbol on a product means that it must be disposed of separately from household waste. When a product marked with this symbol reaches its end of life, take it to a collection point designated by the local waste disposal authorities. The separate collection and recycling of such products will help protect the environment and human health.

See also end-of-life information at [www.grundfos.com/product-recycling](http://www.grundfos.com/product-recycling).

## 13. Document quality feedback

To provide feedback about this document, use your smart device to scan the QR code.



FEEDBACK93103355

[Click here to submit your feedback](#)

## Installation in the USA and Canada

### 1. Installation in the USA and Canada



To maintain the cURus approval, the additional information in this section must be followed.

#### Environmental enclosure ratings

The MGE, MLE Model K enclosure is approved for NEMA type 12 and is suitable for indoor use only.

The MGE, MLE Model J enclosure is approved for NEMA type 2 and is suitable for indoor use only.

The MGE, MLE Model H and I enclosure is approved for NEMA type 2 and is suitable for indoor use only.

For more information about ambient temperature during operation, see the sections on operating conditions and ambient temperature.

#### EMC statements for USA

This equipment has been tested and found to comply with the limits for a Class A digital device, pursuant to part 15 of the FCC Rules. These limits are designed to provide reasonable protection against harmful interference when the equipment is operated in a commercial environment. This equipment generates, uses, and can radiate radio frequency energy and, if not installed and used in accordance with the instruction manual, may cause harmful interference to radio communications. Operation of this equipment in a residential area is likely to cause harmful interference in which case the user will be required to correct the interference at his own expense.



MLE motors of the C2 emission category fulfill the limits of Class A.

This equipment has been tested and found to comply with the limits for a Class B digital device, pursuant to part 15 of the FCC Rules. These limits are designed to provide reasonable protection against harmful interference in a residential installation. This equipment generates, uses, and can radiate radio frequency energy and, if not installed and used in accordance with the instructions, may cause harmful interference to radio communications. However, there is no guarantee that interference will not occur in a particular installation. If this equipment does cause harmful interference to radio or television reception, which can be determined by turning the equipment off and on, the user is encouraged to try to correct the interference by one or more of the following measures:

- Reorient or relocate the receiving antenna.
- Increase the separation between the equipment and receiver.
- Connect the equipment into an outlet on a circuit different from that to which the receiver is connected.
- Consult the dealer or an experienced radio/TV technician for help.



MLE motors of the C1 emission category fulfill the limits of Class B.



MLE motors of the C3 emission category can only be used in industrial plants and public utilities in accordance with FCC § 15.103(b) and ICES 003 § 1.5.1(c). In other locations, MLE motors of the C1 or C2 emission category must be used.

#### Canadian Interference-Causing Equipment Standard

MLE Model H, I complies with the Canadian ICES-003 Class B specifications. This Class B device meets all the requirements of the Canadian interference-causing equipment regulations.

MLE Model J complies with the Canadian ICES-003 Class B specifications. This Class B device meets all the requirements of the Canadian interference-causing equipment regulations.

MLE Model K complies with the Canadian ICES-003 Class A specifications. This Class A device meets all the requirements of the Canadian interference-causing equipment regulations.

#### Hot surface

The product might reach a surface temperature of 149 °F (65 °C), therefore pay attention when operating the product.

The following marking is found on the product:



TM084167

### 2. Radio communication

#### For the USA and Canada

#### CAUTION

##### Radiation

Minor or moderate personal injury



- This equipment complies with FCC and ISED radiation exposure limits set forth for an uncontrolled environment. This equipment must be installed and operated with a minimum distance of 8 inches (20 cm) between the radiator and your body.



This device complies with Part 15 of the FCC rules and RSS210 of the IC rules.



Changes or modifications made to this equipment not expressly approved by Grundfos may void the FCC authorization to operate this equipment.

Operation is subject to the following two conditions:

- This device may not cause interference.
- This device must accept any interference, including interference that may cause undesired operation of the device.

### 3. Identification numbers

#### For the USA

Grundfos Holding A/S

Contains FCC ID: OG3-RADIOM01-2G4

Contains FCC ID: OG3-RA2G4MSR.

#### For Canada

Grundfos Holding A/S

Model: RADIOMODULE 2G4

Contains IC: 10447A-RA2G4M01

Contains IC: 10447A-RA2G4MSR.

## 4. Electrical connection

### Installation altitude

For corner earthed grid systems: The maximum altitude is 6560 ft (2000 m) above sea level.

For all other grid systems: The maximum altitude is 11480 ft (3500 m) above sea level.

### Conductors

See the sections on electrical installation and cable requirements.

### Conductor temperature ratings

**Model J:** Use minimum 140 °F (60 °C) copper conductors.

**Model K:** Use 167 °F (75 °C) copper conductors only. The wire sizes for the supply mains must be sized for a wire size which is suitable for at least 125% of the rated input current of the motor drive units.

### Recommended ring terminals



Ensure that the used ring terminals are UL certified.

The supply terminals are suitable for field wiring when used with stranded wires and specific listed crimp terminals manufactured by Tyco Electronics (E13288).

Cable cross-section		Part number/ Designation number	Manufacturer
[mm <sup>2</sup> ]	[AWG]		
16	6	130552	Tyco Electronics
10	8	160013	Tyco Electronics
6	10	130191	Tyco Electronics

### Ethernet cable connection

The connection of Ethernet cables must be done by connecting the Ethernet cable screen to an earth clamp on the terminal box, to be in compliance with FCC and ISED requirements.

The recommended Ethernet cable types for earth clamp applications are SF/UTP, S/FTP or SF/FTP, where the cable screen consists of both a braided and a foil screen.

### Torques

See the section on torques.

### Line reactors

Line reactors are often required for six-pulse variable speed drives. Please observe that the MGE, MLE utilize a small DC capacitor concept for lower harmonics and exceeding the maximum inductance may cause resonance between reactor and the MGE, MLE that will reduce the lifetime of the product.

### Short-circuit current

**Model J:** If a short circuit occurs, the motor can be used on a mains supply delivering not more than 5000 RMS symmetrical amperes, 600 V maximum.

**Model K:** Suitable for use on a circuit capable of delivering not more than 5000 rms symmetrical amperes, when protected by RK1, J or T Class fuses, rated 80 A, 600 V.

### Fuses

**Model J:** Fuses used for motor protection must be rated for a minimum of 600 V. Motors up to and including 7.5 kW (10 hp) require class K5 UL-listed fuses rated 35A by Cooper Bussman or alternative fuse type and size can be used, if considerations are made, to determine if it is needed to repeat component fault testing during end-product investigations. Any UL-listed fuse can be used for motors of 15 hp (11 kW).

**Model K:** Fuses used for motor protection must be rated for minimum 600 V.



For fuse sizes, see the section on recommended size of fuses.

### 3 × 440-480 V, MLE Model J

Motor size [HP]	Recommended [A]	Maximum [A]	Fuse type
5	13	16	K5 UL listed fuse
7 1/2	16	32	K5 UL listed fuse
10	20	32	K5 UL listed fuse
15	32	32	K5 UL listed fuse

### 3 × 440-480 V, MLE Model K

Motor size [hp]	Recommended [A]	Maximum [A]	Fuse type
20	50	80	RK1, Class J or T UL listed fuse
25	60	80	RK1, Class J or T UL listed fuse
30	70	80	RK1, Class J or T UL listed fuse

### 3 × 200-240 V, MLE Model J

Motor size [HP]	Recommended [A]	Maximum [A]	Fuse type
3	13	35	K5 UL listed fuse
5	25	35	K5 UL listed fuse
7 1/2	32	35	K5 UL listed fuse

### 3 × 200-240 V, MLE Model K

Motor size [hp]	Recommended [A]	Maximum [A]	Fuse type
10	70	80	RK1, Class J or T UL listed fuse
15	80	80	RK1, Class J or T UL listed fuse

### Branch-circuit protection for MLE Model J

When the pump is protected by a circuit breaker, the circuit breaker must be rated for a minimum voltage of 500 V. The circuit breaker must be of the inverse-time type.

### Branch circuit short-circuit protection

#### For the USA

Integral solid state short-circuit protection does not provide branch circuit protection. Branch circuit protection must be provided in accordance with the National Electrical Code and any additional local codes, or the equivalent.

#### For Canada

INTEGRAL SOLID STATE SHORT-CIRCUIT PROTECTION DOES NOT PROVIDE BRANCH CIRCUIT PROTECTION. BRANCH CIRCUIT PROTECTION MUST BE PROVIDED IN ACCORDANCE WITH THE CANADIAN ELECTRICAL CODE, PART I.

**Overload protection**

Degree of overload protection provided internally by the drive, in percent of full-load current: 102 %.

## Installation aux États-Unis et au Canada

### 1. Installation aux États-Unis et au Canada



Pour conserver l'homologation cURus, les informations supplémentaires de cette section doivent être respectées.

#### Caractéristiques environnementales du boîtier

Le boîtier MGE, MLE Modèle K est homologué pour le type 12 de la NEMA et convient uniquement à une utilisation à l'intérieur.

Le boîtier MGE, MLE Modèle J est homologué pour le type 2 de la NEMA et convient uniquement à une utilisation à l'intérieur.

Le boîtier MGE, MLE Modèle H et I est homologué pour le type 2 de la NEMA et convient uniquement à une utilisation à l'intérieur.

Pour plus d'informations concernant la température ambiante en fonctionnement, voir les sections Conditions de fonctionnement et Température ambiante.

#### Déclarations EMC pour les États-Unis

Cet équipement a été testé et déclaré conforme aux limites imposées aux dispositifs numériques de classe A, conformément à la partie 15 des règles de la FCC. Ces limites sont conçues pour fournir une protection raisonnable contre les interférences nuisibles dans une installation collective. Cet équipement génère, utilise et peut émettre des fréquences radio et, s'il n'est pas installé et utilisé conformément à la notice d'installation et de fonctionnement, peut causer des interférences nuisibles aux communications radio. L'utilisation de cet équipement dans une zone résidentielle est susceptible de provoquer des interférences nuisibles que l'utilisateur devra corriger à ses frais.



Les moteurs MLE de la catégorie d'émissions C2 respectent les limites de la classe A.

Cet équipement a été testé et déclaré conforme aux limites d'un appareil numérique de classe B, conformément à la partie 15 des règles de la FCC. Ces limites sont conçues pour fournir une protection raisonnable contre les interférences nuisibles dans une installation résidentielle. Cet équipement génère, utilise et peut émettre de l'énergie de fréquences radio et, s'il n'est pas installé et utilisé conformément aux instructions, peut causer des interférences nuisibles aux communications radio. Toutefois, il n'est pas garanti qu'aucune interférence ne se produira dans une installation donnée. Si cet équipement provoque des interférences nuisibles à la réception de la radio ou de la télévision, ce qui peut être déterminé en allumant et en éteignant l'équipement, l'utilisateur est encouragé à essayer de corriger les interférences en prenant une ou plusieurs des mesures suivantes :

- Réorienter ou déplacer l'antenne de réception.

### 2. Communication radio

Pour les États-Unis et le Canada

#### PRÉCAUTIONS

##### Radiation

Blessures corporelles mineures à modérées



- Cet équipement est conforme aux limites d'exposition aux rayonnements définies par la FCC et l'ISDE pour un environnement non contrôlé. Cet équipement doit être installé et utilisé à une distance minimale de 20 cm (0,66 pi) entre le radiateur et votre corps.



Cet appareil est conforme à la section 15 de la réglementation FCC et à RSS210 de la réglementation IC.

- Augmenter la distance entre l'équipement et le récepteur.
- Brancher l'équipement sur une prise reliée à un circuit différent de celui du récepteur.
- Consulter le revendeur ou un technicien radio/TV expérimenté pour obtenir de l'aide.



Les moteurs MLE de catégorie d'émission C1 respectent les limites de la classe B.



Les moteurs MLE de catégorie d'émission C3 peuvent être utilisés uniquement dans des installations industrielles ou des services publics, conformément à la norme FCC § 15.103(b) et ICES 003 § 1.5.1(c). Dans d'autres cas, il faut utiliser des moteurs MLE de catégorie d'émission C1 ou C2.

#### Norme canadienne relative aux équipements générateurs de parasites

Le MLE Modèle H, I est conforme à la norme NMB-003 du Canada pour le matériel de classe B. L'appareil de classe B est conforme à toutes les exigences du règlement canadien s'appliquant aux équipements générateurs de parasites.

Le MLE Modèle J, est conforme à la norme NMB-003 du Canada pour le matériel de classe B. L'appareil de classe B est conforme à toutes les exigences du règlement canadien s'appliquant aux équipements générateurs de parasites.

Le MLE Modèle K, est conforme à la norme NMB-003 du Canada pour le matériel de classe A. L'appareil de classe A est conforme à toutes les exigences du règlement canadien s'appliquant aux équipements générateurs de parasites.

#### Surface chaude

Le produit peut atteindre une température de surface de 149 °F (65 °C), par conséquent faire preuve de prudence lors de l'utilisation.

Le marquage suivant est apposé sur le produit :



Les changements ou modifications apportés à cet équipement qui ne sont pas expressément approuvés par Grundfos peuvent annuler l'autorisation de la FCC à utiliser cet équipement.

Son fonctionnement est soumis aux deux conditions suivantes:

- Ce dispositif ne doit pas provoquer de brouillage préjudiciable.
- Il doit accepter tout brouillage reçu, y compris le brouillage pouvant entraîner un mauvais fonctionnement.

### 3. Numéros d'identification

#### Pour les États-Unis

Grundfos Holding A/S  
 Contient FCC ID: OG3-RADIOM01-2G4  
 Contient FCC ID: OG3-RA2G4MSR.

#### Pour le Canada

Numéros d'identification:

### 4. Branchement électrique

#### Altitude d'installation

Pour les réseaux avec mise à la terre en coin : L'altitude maximale est de 6 560 pi (2 000 m) au-dessus du niveau de la mer.

Pour tous les autres réseaux : L'altitude maximale est de 11 480 pi (3 500 m) au-dessus du niveau de la mer.

#### Conducteurs

Voir les sections sur l'installation électrique et les exigences relatives aux câbles.

#### Température nominale du conducteur

**Modèle J** : Utiliser des conducteurs en cuivre de 140 °F (60 °C) minimum.

**Modèle K** : Utiliser uniquement des conducteurs en cuivre de 167 °F (75 °C). Le calibre des fils du réseau d'alimentation doit être dimensionné pour convenir à au moins 125 % du courant d'entrée nominal des unités d'entraînement motorisées.

#### Bornes à œillets recommandées



Veiller à utiliser des bornes à œillets certifiées UL.

Les bornes d'alimentation sont adaptées au câblage sur site lorsqu'elles sont utilisées avec des fils toronnés et des bornes à sertir spécifiques homologuées, fabriquées par Tyco Electronics (E13288).

Section de câble		Numéro de pièce / Désignation numéro	Fabricant
[mm <sup>2</sup> ]	[AWG]		
16	6	130552	Tyco Electronics
10	8	160013	Tyco Electronics
6	10	130191	Tyco Electronics

#### Connexion du câble Ethernet

La connexion des câbles Ethernet doit être effectuée en reliant le blindage du câble Ethernet à une borne de mise à la terre sur le boîtier de raccordement pour être conforme aux exigences FCC et ISED.

Les types de câbles Ethernet recommandés pour les applications de mise à la terre sont SF/UTP, S/FTP ou SF/FTP, où le blindage du câble est constitué d'une tresse et d'une feuille.

#### Couples de serrage

Voir la section sur les couples de serrage.

#### Réacteurs de ligne

Les réacteurs de ligne sont souvent nécessaires pour les entraînements à vitesse variable à six impulsions. Remarque : les modèles MGE et MLE utilisent un petit condensateur CC pour réduire les harmoniques. Le dépassement de l'inductance maximale peut provoquer une résonance entre le réacteur et les modèles MGE et MLE, ce qui réduit la durée de vie du produit.

Grundfos Holding A/S

Modèle: RADIOMODULE 2G4

Contient IC: 10447A-RA2G4M01

Contient IC: 10447A-RA2G4MSR.

#### Intensité de court-circuit

**Modèle J** : En cas de court-circuit, le moteur peut être utilisé avec une alimentation réseau fournissant au maximum 5 000 ampères symétriques RMS, 600 V maximum.

**Modèle K** : Convient à une utilisation sur un circuit capable de fournir au maximum 5 000 ampères RMS symétriques, lorsqu'il est protégé par des fusibles de classe RK1, J ou T, 80 A, 600 V.

#### Fusibles

**Modèle J** : Les fusibles utilisés pour la protection du moteur doivent être calibrés pour une tension minimale de 600 V. Les moteurs jusqu'à 7,5 kW (10 hp) inclus nécessitent des fusibles de classe K5 homologués UL calibrés à 35 A de marque Cooper Bussman. D'autres types et calibres de fusibles peuvent être utilisés, après avoir déterminé s'il est nécessaire de répéter les tests de défaillance des composants lors de l'évaluation du produit final. Tout fusible homologué UL peut être utilisé pour les moteurs de 15 hp (11 kW).

**Modèle K** : Les fusibles utilisés pour la protection des moteurs doivent être calibrés pour une tension minimale de 600 V.



Pour les calibres des fusibles, voir la section sur les tailles recommandées de fusibles.

#### 3 × 440-480 V, MLE modèle J

Taille moteur [HP]	Recommandé [A]	Maximum [A]	Type de fusible
5	13	16	Fusible homologué K5 UL
7 1/2	16	32	Fusible homologué K5 UL
10	20	32	Fusible homologué K5 UL
15	32	32	Fusible homologué K5 UL

#### 3 × 440-480 V, MLE modèle K

Taille moteur [hp]	Recommandé [A]	Maximum [A]	Type de fusible
20	50	80	Fusible homologué UL de classe RK1, J ou T

Taille moteur [hp]	Recommandé [A]	Maximum [A]	Type de fusible
25	60	80	Fusible homologué UL de classe RK1, J ou T
30	70	80	Fusible homologué UL de classe RK1, J ou T

### 3 × 200-240 V, MLE modèle J

Taille moteur [HP]	Recommandé [A]	Maximum [A]	Type de fusible
3	13	35	Fusible homologué K5 UL
5	25	35	Fusible homologué K5 UL
7 1/2	32	35	Fusible homologué K5 UL

### 3 × 200-240 V, MLE modèle K

Taille moteur [hp]	Recommandé [A]	Maximum [A]	Type de fusible
10	70	80	Fusible homologué UL de classe RK1, J ou T
15	80	80	Fusible homologué UL de classe RK1, J ou T

### Protection du circuit de dérivation pour le produit MLE modèle J

Lorsque la pompe est protégée par un disjoncteur, celui-ci doit être calibré pour une tension minimale de 500 V. Le disjoncteur doit être de type à temporisation inverse.

### Protection contre les courts-circuits du circuit de dérivation Pour les États-Unis

La protection intégrée contre les courts-circuits à semi-conducteurs n'assure pas la protection du circuit de dérivation. La protection du circuit de dérivation doit être assurée conformément au Code national de l'électricité et à toute réglementation locale supplémentaire, ou à une réglementation équivalente.

### Pour le Canada

LA PROTECTION INTÉGRÉE CONTRE LES COURTS-CIRCUITS À SEMI-CONDUCTEURS NE CONSTITUE PAS UNE PROTECTION DU CIRCUIT DE DÉRIVATION. LA PROTECTION DES CIRCUITS DE DÉRIVATION DOIT ÊTRE ASSURÉE CONFORMÉMENT AU CODE CANADIEN DE L'ÉLECTRICITÉ, PARTIE I.

### Protection contre les surcharges

Degré de protection contre les surcharges assurée en interne par l'entraînement, en pourcentage de l'intensité à pleine charge : 102 %.

## Limited consumer warranty

### 1. Limited consumer warranty

This Limited Warranty is provided for Consumer Products sold in the United States only and applies to Consumer Transactions as defined in and applicable under the Magnusson-Moss Warranty Act and any other applicable Federal and/or State laws. In case of non-Consumer Products, please refer to Grundfos' warranty terms defined in clause 10 of Grundfos US Terms and Conditions of Sale of Product and Services available at <https://www.grundfos.com/legal/grundfos-customer-terms/usa-grundfos-general-terms-for-sales-of-products-and-services>

**This Limited Warranty gives you specific legal rights, and you may also have other rights which vary from State to State.**

New products manufactured by Grundfos are warranted to the original purchaser only and are to be free from defects in design, material and workmanship under normal use and service for no greater than a period of thirty (30) months from the date of manufacture which is set forth on the product's nameplate and on the product's packaging or the minimum period required by the applicable State law. For New Jersey, the applicable period is one year from the date of purchase.

The warranty period for replacement products, parts and components expires thirty (30) months from the original date of manufacture of the product originally purchased, unless a longer period is required under the applicable State law. For New Jersey, the warranty period for replacement products, parts and components expires one year from the original date of purchase of the product, not the date of replacement.

Products sold by Grundfos that are manufactured by others are not covered by this warranty.

**Note that when purchasing a Grundfos product online, it is important to check the date of manufacture and the duration of the warranty with the seller as the product might no longer be covered under this Limited Warranty.**

**When a product is subject to this Limited Warranty a purchaser should contact the seller from which it purchased the product to make a claim.**

If the seller of a product is no longer in business, the purchaser should contact a Grundfos Authorized Service Partner, which can be found at [www.grundfos.com/us](http://www.grundfos.com/us) under > Support > Contact Service.

As part of making a claim, a purchaser shall return a defective product at the purchaser's cost, to the extent allowed by applicable law, along with proof of purchase and an explanation of the defect, date the defect occurred and circumstances surrounding the defect. For New Jersey there is no prohibition on returning a defective product at a purchaser's cost. If Grundfos is required by applicable State law to pay for the cost of shipment under applicable State law, then a purchaser should contact a Grundfos Authorized Service Partner to arrange for shipment. A purchaser also needs to promptly respond to Grundfos as to any inquiries regarding a warranty claim.

**Grundfos' liability under this Limited Warranty to purchaser is limited to the repair or replacement of a product (at Grundfos' decision) that is the sole and exclusive remedy for purchaser to the extent permissible by applicable law.** For New Jersey this limitation is permissible.

This warranty does not cover the following: ordinary wear and tear; use of a product for applications for which it is not intended; use of a product in an unsuitable environment; modifications, alterations or repair undertaken by anyone not acting with Grundfos' written authorization; failure to follow Grundfos' instructions, operations manuals, any other guidelines or good industry practice; use of faulty or inadequate ancillary equipment in combination with a product; application of spare or replacement parts not provided or authorized by Grundfos; accidental or intentional damage or misuse of a product.

The time period for making a claim under the implied warranty of merchantability and implied warranty of fitness are limited to the same time period as provided by this warranty to the extent permissible by applicable law. For residents of New Jersey, this limitation is permissible, but note that some states do not allow limitations on how long an implied warranty lasts, so the above limitation may not apply to you.

**Grundfos shall not be liable for any incidental and consequential damages in connection with a product to the extent permissible by applicable law.** For residents of New Jersey, this limitation is permissible, but note that some states do not allow limitations of incidental or consequential damages, so the above limitation may not apply to you.

## 2. Garantía limitada del consumidor

Esta garantía limitada se proporciona únicamente para los productos de consumo vendidos en los Estados Unidos y es aplicable a las transacciones de consumo tal y como se define en y resulta aplicable en virtud de la ley de Garantías Magnusson-Moss y cualquier otra legislación federal y/o estatal aplicable. Para el caso de productos que no sean de consumo, consulte los términos de la garantía de Grundfos definidos en la cláusula 10 de los términos y condiciones de venta de productos y servicios de Grundfos para los EE. UU., disponibles en <https://www.grundfos.com/legal/grundfos-customer-terms/usa-grundfos-general-terms-for-sales-of-products-and-services>.

**Esta garantía limitada le confiere derechos legales específicos. Puede que también tenga otros derechos en virtud de su jurisdicción estatal.**

Se garantiza únicamente al comprador original que los productos fabricados por Grundfos estarán libres de defectos de diseño, materiales y mano de obra en condiciones normales de uso y servicio durante un periodo no mayor a treinta (30) meses a partir de la fecha de fabricación que figura en la placa de datos del producto y en el empaque del mismo o el periodo mínimo exigido por la legislación estatal aplicable. Para Nueva Jersey, el periodo aplicable es de un año a partir de la fecha de compra.

El periodo de garantía para los productos, partes y componentes de repuesto vence a los treinta (30) meses contados a partir de la fecha de fabricación original del producto adquirido en primer lugar, a menos que la legislación estatal aplicable exija un periodo más largo. Para Nueva Jersey, el periodo de garantía de los productos, partes y componentes de repuesto vence un año contado a partir de la fecha original de compra del producto, no de la fecha de sustitución.

Los productos vendidos por Grundfos que sean producidos por otros fabricantes no están cubiertos por esta garantía.

**Tenga en cuenta que, al comprar un producto Grundfos en línea, es importante revisar la fecha de fabricación y la duración de la garantía con el vendedor, ya que es posible que el producto ya no esté cubierto por esta garantía limitada.**

**Cuando un producto esté sujeto a esta garantía limitada, el comprador deberá ponerse en contacto con el vendedor al que haya comprado el producto para presentar una reclamación.**

Si el vendedor de un producto ya no está en el negocio, el comprador debe ponerse en contacto con socio de servicio autorizado por Grundfos, que puede encontrar en la dirección [www.grundfos.com/us](http://www.grundfos.com/us), en la sección "Support" > "Contact Service".

Como parte de la presentación de una reclamación, el comprador deberá devolver el producto descompuesto a su costa, en la medida en la que lo permita la legislación aplicable, junto con el comprobante de compra y una explicación del defecto, la fecha en que este se haya producido y las circunstancias en torno al defecto. En Nueva Jersey no existe ninguna prohibición de devolver un producto descompuesto a costa del comprador. Si la legislación estatal aplicable obliga a Grundfos a hacerse cargo de los gastos de envío, el comprador deberá ponerse en contacto con un servicio técnico autorizado por Grundfos para organizar el envío. El comprador también debe responder con prontitud a Grundfos cualquier consulta relacionada con una reclamación de garantía.

**La responsabilidad de Grundfos hacia el comprador en virtud de esta garantía limitada se limita a la reparación o sustitución de un producto (a decisión de Grundfos), que es el único y exclusivo remedio para el comprador en la medida permitida por la legislación aplicable.** Para Nueva Jersey, esta limitación resulta permisible.

Esta garantía no cubre lo siguiente: el desgaste ordinario; el uso de un producto para aplicaciones para las que no está diseñado; el uso de un producto en un entorno inadecuado; las modificaciones, alteraciones o reparaciones realizadas por cualquier persona que no actúe con la autorización por escrito de Grundfos; el incumplimiento de las instrucciones, manuales de operación, cualquier otro lineamiento o las buenas prácticas industriales de Grundfos; el uso de equipos auxiliares descompuestos o inadecuados en combinación con un producto; el uso de repuestos o partes de sustitución no proporcionados ni autorizados por Grundfos; el daño accidental o deliberado o el uso indebido de un producto.

El periodo para presentar una reclamación en virtud de la garantía implícita de comerciabilidad y la garantía implícita de idoneidad se limita al mismo periodo previsto por esta garantía en la medida permitida por la legislación aplicable. Para los residentes de Nueva Jersey, esta limitación resulta permisible, si bien se debe tener en cuenta que algunos estados no permiten limitaciones en cuanto a la duración de una garantía implícita, por lo que la limitación anterior puede no resultar aplicable en su caso.

**Grundfos no será responsable de ningún daño indirecto o consecuente en relación con un producto en la medida en la que lo permita la legislación aplicable.** Para los residentes de Nueva Jersey, esta limitación resulta permisible, si bien debe tenerse en cuenta que algunos estados no permiten limitaciones en cuanto a daños indirectos o consecuentes, por lo que la limitación anterior puede no resultar aplicable en su caso.

## Limited manufacturer's warranty

### 1. Limited manufacturer's warranty

This Limited Manufacturer's Warranty outlines applicable coverage and claims procedures for the pumps manufactured by Grundfos (the "Product").

This Limited Manufacturer's Warranty is provided for consumer products sold and used in Canada only and applies to consumer transactions as defined in the applicable provincial and territorial laws. In case of non-consumer products, please refer to Grundfos' warranty terms defined in clause 10 of Grundfos Canada Terms and Conditions of Sale of Product and Services available at: <https://www.grundfos.com/ca/legal/general-terms-and-conditions-of-sales-and-delivery>

This Limited Manufacturer's Warranty provides specific rights and limitations. Some of the limitations may not apply to you, and you may also have other rights that vary from province to province.

#### Scope of the Limited Manufacturer's Warranty

Subject to the following warranty terms and conditions, Grundfos Canada Inc. of 2941 Brighton Rd, Oakville, ON L6H 6C9, Canada ("Grundfos"), warrants to the original consumer (the "Purchaser") that the new Product manufactured by Grundfos is free from defects in design, material and workmanship under normal use and service for a period of twenty-four (24) months from the date of retail purchase but no greater than a period of thirty (30) months from the date of manufacture which is set forth on the Product's nameplate and on the Product's packaging (the "Warranty Period").

**Note that when purchasing a Grundfos Product online, it is important to check the date of manufacture and the duration of the warranty with the seller as the Product might no longer be covered under this Limited Manufacturer's Warranty.**

This Limited Manufacturer's Warranty applies exclusively to a new Grundfos Product sold and used in Canada. This Limited Manufacturer's Warranty does not apply to any Product sold "as is" or "sales final". This Limited Manufacturer's Warranty is not transferrable by the original Purchaser. Products sold by Grundfos that are manufactured by others are not covered by this warranty.

The sole and exclusive remedy under this Limited Manufacturer's Warranty is the repair or, at the discretion of Grundfos, the replacement of the Product, as set out below. Defects or damages are not covered by the Limited Manufacturer's Warranty if they are due to:

- ordinary wear and tear;
- use of the Product for an application for which it is not intended;
- installation of the Product in an environment not suitable for the Product;
- any modification, alteration or repair of the Product undertaken by the Purchaser or a third party (not acting on Grundfos' behalf);
- failure to follow Grundfos' instructions, including in the installation manual, operation manual, maintenance manual or service manual;
- installation, commissioning, operation (including the use of the Product or any Grundfos product outside its specifications) or maintenance of the Product other than in accordance with Grundfos installation manual, operation manual, maintenance manual or service manual or with good industry practice;
- use of faulty or inadequate ancillary equipment in combination with the Product;
- the application of spare parts of poor quality (excluding the application of any Grundfos original spare parts);
- accidental or intentional damage or misuse of the Products or services by the Purchaser or a third party (not acting on Grundfos' behalf); or
- the non-compliance of the Purchaser or of the Purchaser's own products with applicable law and regulation.

#### How to get service under the Limited Manufacturer's Warranty:

When a Product is subject to this Limited Manufacturer's Warranty, the Purchaser should contact the seller from which it purchased the Product to make a claim within 24 months from the date of retail purchase but no later than thirty (30) months from the date of manufacture which is set forth on the Product's nameplate and on the Product's packaging (the "Warranty Notification Period").

If the seller of a Product is no longer in business, the Purchaser should contact Grundfos Service at [www.grundfos.com/us](http://www.grundfos.com/us) under **Support > Contact Service**.

To exercise the rights under this Limited Manufacturer's Warranty, the Purchaser shall return a defective Product at the Purchaser's cost, to the extent allowed by applicable law, along with proof of purchase and an explanation of the defect, date the defect occurred and circumstances surrounding the defect.

The Purchaser is responsible for any expenses for dismounting and mounting the Product and for any and costs related to removal, reinstallation, transportation, and insurance. If Grundfos is required by applicable provincial or territorial law to pay for the cost of transportation, then the Purchaser should contact Grundfos Service Partner to arrange for shipment. The Purchaser also needs to promptly respond to Grundfos as to any inquiries regarding a warranty claim.

Unless requested by Grundfos, the Product may not be disassembled prior to remedy. Any failure to comply herewith will render this Limited Manufacturer's Warranty void.

Grundfos will either arrange the repair of the defective Product under this Limited Manufacturer's Warranty or, at Grundfos' option, provide the Purchaser with a replacement of the defective Product. The replacement unit can be new or remanufactured.

**To the extent permissible by applicable law, Grundfos shall not be liable for any incidental and consequential damages or losses of any kind whatsoever arising under, relating to or in connection with the Product, use of the Product or the inability to use the Product.**

## 2. Garantie limitée du fabricant

Cette garantie limitée du fabricant décrit la couverture applicable et les procédures de réclamation pour les pompes fabriquées par Grundfos (ci-après le « Produit »).

Cette garantie limitée du fabricant est fournie pour les produits de consommation vendus et utilisés au Canada uniquement et s'applique aux transactions de consommateurs telles que définies dans les lois provinciales et territoriales applicables. Dans le cas de produits non destinés aux consommateurs, se référer aux conditions de garantie de Grundfos définies à l'article 10 des Conditions générales de vente des produits et services de Grundfos Canada, qui sont disponibles à l'adresse suivante : <https://www.grundfos.com/ca/fr/legal/general-terms-and-conditions-of-sales-and-delivery>

Cette garantie limitée du fabricant prévoit des droits et des limitations spécifiques. Certaines des limitations peuvent ne pas s'appliquer à vous, et vous pouvez également bénéficier d'autres droits qui varient d'une province à l'autre.

### Champ d'application de la garantie limitée du fabricant

Sous réserve des conditions générales de garantie suivantes, Grundfos Canada Inc., dont le siège social est situé au 2941, Brighton Rd, Oakville, ON L6H 6C9, Canada (ci-après « Grundfos »), garantit au consommateur initial (ci-après « l'Acheteur ») que le nouveau Produit fabriqué par Grundfos est exempt de défauts de conception, de matériaux et de fabrication dans des conditions normales d'utilisation et d'entretien pendant une période de vingt-quatre (24) mois à compter de la date d'achat au détail, mais pas plus de trente (30) mois à compter de la date de fabrication indiquée sur la plaque signalétique et sur l'emballage du Produit (« Période de garantie »).

**Lors de l'achat d'un Produit Grundfos en ligne, il est important de vérifier la date de fabrication et la durée de la garantie auprès du vendeur, car le Produit pourrait ne plus être couvert par cette garantie limitée du fabricant.**

Cette garantie limitée du fabricant s'applique exclusivement à un Produit Grundfos neuf vendu et utilisé au Canada. Cette garantie limitée du fabricant ne s'applique pas aux Produits vendus « en l'état » ou « vente finale ». La présente garantie limitée du fabricant n'est pas transférable par l'Acheteur initial. Les produits vendus par Grundfos qui sont fabriqués par des tiers ne sont pas couverts par cette garantie.

Le seul et unique recours dans le cadre de cette garantie limitée du fabricant est la réparation ou, à la discrétion de Grundfos, le remplacement du Produit, comme indiqué ci-dessous. Les défauts ou dommages ne sont pas couverts par la garantie limitée du fabricant s'ils sont dus à :

- l'usure normale ;
- l'utilisation du Produit pour une application pour laquelle il n'est pas prévu ;
- l'installation du Produit dans un environnement non adapté au Produit ;
- toute modification, altération ou réparation du Produit entreprise par l'Acheteur ou un tiers (n'agissant pas pour le compte de Grundfos) ;
- la non-observation des instructions de Grundfos, y compris dans les notices d'installation, d'utilisation, de maintenance ou d'entretien ;
- l'installation, la mise en service, l'utilisation (y compris l'utilisation du Produit ou de tout produit Grundfos en dehors de ses spécifications) ou l'entretien du Produit autrement que conformément aux notices d'installation, d'utilisation, de maintenance ou d'entretien Grundfos ou aux bonnes pratiques de l'industrie ;
- l'utilisation d'un équipement auxiliaire défectueux ou inadéquat en combinaison avec le Produit ;
- l'utilisation de pièces de rechange de mauvaise qualité (à l'exclusion de l'utilisation de pièces de rechange d'origine Grundfos) ;
- tout dommage accidentel ou intentionnel ou toute mauvaise utilisation des Produits ou des services par l'Acheteur ou un tiers (n'agissant pas pour le compte de Grundfos) ; ou
- la non-conformité de l'Acheteur ou de ses propres produits aux lois et règlements applicables.

### Procédure à suivre pour bénéficier d'un service dans le cadre de la garantie limitée du fabricant :

Lorsqu'un Produit est soumis à la présente garantie limitée du fabricant, l'Acheteur doit contacter le vendeur auprès duquel il a acheté le produit pour faire une réclamation dans les 24 mois suivant la date d'achat au détail, mais au plus tard trente (30) mois à compter de la date de fabrication indiquée sur la plaque signalétique du Produit et sur l'emballage du Produit (« Période de notification de garantie »).

Si le vendeur d'un Produit n'est plus en activité, l'Acheteur doit contacter le service Grundfos à l'adresse [www.grundfos.com/us](http://www.grundfos.com/us) sous **Support > Contact Service**.

Pour exercer les droits prévus par la présente garantie limitée du fabricant, l'Acheteur doit renvoyer le Produit défectueux à ses frais, dans la mesure où la loi applicable le permet, accompagné de la preuve d'achat et d'une explication du défaut, de la date à laquelle le défaut s'est produit et des circonstances entourant le défaut.

L'Acheteur est responsable de tous les frais de démontage et de montage du Produit et de tous les frais liés à l'enlèvement, à la réinstallation, au transport et à l'assurance. Si Grundfos est tenu par la loi provinciale ou territoriale applicable de payer les frais de transport, l'Acheteur doit contacter le partenaire de service Grundfos pour organiser l'expédition. L'Acheteur doit également répondre rapidement à Grundfos pour toute demande concernant une réclamation au titre de la garantie.

Sauf demande de Grundfos, le Produit ne doit pas être démonté avant d'être remis en état. Tout manquement à ces dispositions entraînera l'annulation de la présente garantie limitée du fabricant.

Grundfos procédera à la réparation du Produit défectueux dans le cadre de cette garantie limitée du fabricant ou, à la convenance de Grundfos, fournira à l'Acheteur un produit de remplacement du Produit défectueux. L'unité de remplacement peut être neuve ou refabriquée.

**Dans la mesure autorisée par la loi applicable, Grundfos ne sera pas responsable des dommages accessoires et indirects ou des pertes de quelque nature que ce soit découlant de, liés à ou en rapport avec le Produit, l'utilisation du Produit ou l'incapacité d'utiliser le Produit.**

**U.S.A.**

Global Headquarters for WU  
856 Kooamey Road  
Brookshire, Texas 77423 USA  
Phone: +1-630-236-5500

GRUNDFOS CBS Inc.  
902 Kooamey Road  
Brookshire, TX 77423 USA  
Phone: 281-994-2700  
Toll Free: 1-800-955-5847  
Fax: 1-800-945-4777

GRUNDFOS Pumps Corporation  
9300 Loiret Boulevard  
Lenexa, Kansas 66219 USA  
Tel.: +1 913 227 3400  
Fax: +1 913 227 3500

**Canada**

GRUNDFOS Canada inc.  
2941 Brighton Road  
Oakville, Ontario  
L6H 6C9  
Tel.: +1-905 829 9533  
Fax: +1-905 829 9512

**Mexico**

Bombas GRUNDFOS de México  
S.A. de C.V.  
Boulevard TLC No. 15  
Parque industrial Stiva Aeropuerto  
Apodaca, N.L. 66600  
Tel.: +52-81-8144 4000  
Fax: +52-81-8144 4010

**Revision Info**

Last revised on 05-2024

<b>93103355</b> 11.2025
ECM: 1433703