

HYDROMATIC® HTS50 CAST IRON SUBMERSIBLE HIGH TEMPERATURE EFFLUENT PUMP

Applications:

- Boiler Blow Down Kits
- Condensate Pits
- Hot Water Sumps

The HTS50 Series Pump is a rugged, submersible cast iron pump with a non-clog, vortex impeller and features silicon carbide seals. It has solids handling capability to 3/4" and is designed to handle liquids to 200°F (93°C). Unit has a 1/2 HP single phase motor complete with power cord. 2" NPT vertical discharge is standard.



HYDROMATIC® HTS50 CAST IRON SUBMERSIBLE HIGH TEMPERATURE EFFLUENT PUMP

Pump Characteristics

Pump/Motor Unit	Submersible
Motor	1/2 HP, Class F insulation, Oil-filled, built in thermal overload protection with automatic reset, stainless steel motor shaft and impeller lock nut, 3450 RPM
Electrical	115V, 1 ϕ , 12A, 60 Hz
Switch Type	Tethered
Operation	Automatic On: 17.8" (452 mm) Off: 8.8" (224 mm)
Maximum Liquid Temperature	200°F (93°C)
Solids Handling	3/4" (19 mm)
Power Cord	20' 16-4 S00W-A/S00W

Materials of Construction

Motor/Volute Housing	Cast Iron
Mechanical Seal	Type 6A or equal, Buna-N elastomers, silicon carbide sealing faces, stainless steel metal parts
Impeller	Cast Iron
Exterior Hardware	Stainless Steel
Bearings	Ball type, oil lubricated

PW217-280*

HTS50 Control Box with high Temp Float Switch



*Control box is necessary for the HTS50, and is not included with the pump. You must order it separately.

Performance Data

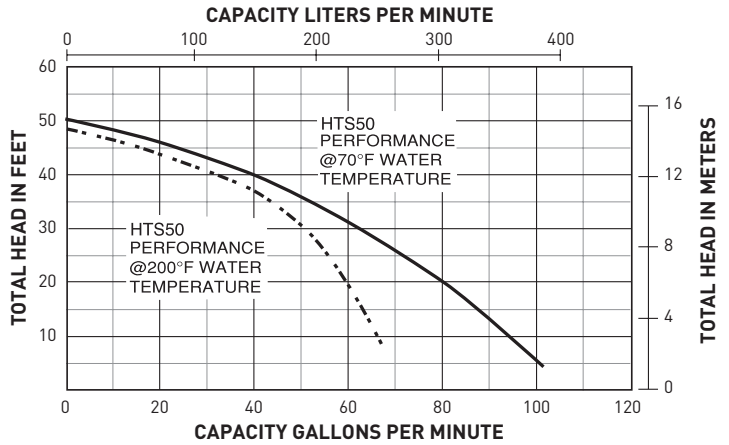

Dimensional Data

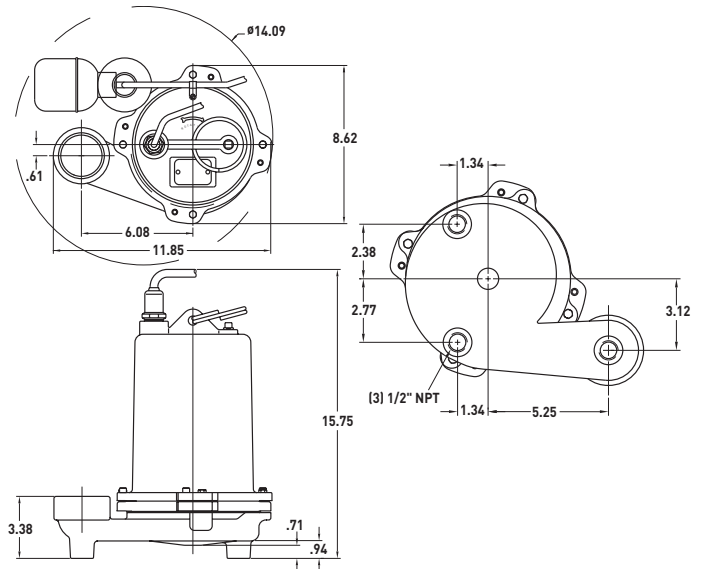

All dimensions in inches. Metric for international use. Component dimensions may vary $\pm 1/8$ inch. Dimensional data not for construction purpose unless certified. Dimensions and weights are approximate. On/Off level adjustable.



USA
293 WRIGHT STREET, DELAVAN, WI 53115 WWW.HYDROMATIC.COM
PH: 888-957-8677 ORDERS FAX: 800-426-9446

CANADA
269 TRILLIUM DRIVE, KITCHENER, ONTARIO, CANADA N2G 4W5
PH: 519-896-2163 ORDERS FAX: 519-896-6337

Because we are continuously improving our products and services, Pentair reserves the right to change specifications without prior notice.