

ROYTRONIC EXCEL™ Series AD Metering Pump

GENERAL

Chemical metering pumps shall be positive displacement, Liquifram™ type pumps with a NEMA 4X/IP-65 enclosure. The external signal/equipment interface shall meet IP-68 standards. Relevant model codes are NSF Certified, UL/CUL or CE certified. Output volume shall be adjustable while pumps are in operation from zero to maximum capacity of:

ROYTRONIC EXCEL™ Series AD with FASTPRIME™ Liquid End

AD91, AD81, AD21	–	0.21 GPH	(0.8 liters per hour)
AD94, AD84, AD24	–	0.50 GPH	(1.9 liters per hour)
AD95, AD85, AD25	–	1.0 GPH	(3.8 liters per hour)
AD96, AD86, AD26	–	2.0 GPH	(7.6 liters per hour)

Chemical metering pumps shall be capable, without a hydraulically backed diaphragm, of injecting solutions against pressures up to:

ROYTRONIC EXCEL™ Series AD with FASTPRIME™ Liquid End

AD91, AD81, AD21	–	250 psi	(17.2 bar)
AD94, AD84, AD24	–	250 psi	(17.2 bar)
AD95, AD85, AD25	–	110 psi	(7.6 bar)
AD96, AD86, AD26	–	50 psi	(3.5 bar)

The FastPrime™ Liquid End² shall be equipped with a valve that allows for opening the head to atmospheric pressure to assist in pump priming. The AutoPrime™ Liquid End³ shall be equipped with a valve that allows for constant removal of vapors and gasses inherent in effervescent chemicals. The AutoPrime™ valve shall enable the pump to be primed automatically.

NOTE: AutoPrime™ liquid ends will recirculate a percentage of discharge chemical back to supply. Depending on application, output may be reduced up to 50%. Variables include supplier piping, stroke length and speed setting. Maximum pressure is 250 psi for ADX1, ADX4, 110 psi for ADX5, 50 psi for ADX6 models¹.

PUMP SPEED:

All models are 120 strokes per minute max.

SERIES AD2

Series AD2 metering pumps shall have a liquid crystal display to indicate stroke speed of the pump and theoretical flow. Control and adjustment for stroke frequency shall be by means of a tactile keypad. Adjustment for stroke length shall be by means of a readily accessible dial knob. A pulse indicator light shall flash green between strokes when pumping. The pump shall be equipped with an on/off button and a low level float switch input. When the low level sensor registers empty, the low level indicator light shall turn red and the pump shall turn off when it registers an empty level.

SERIES AD8

Series AD8 metering pumps shall have a liquid crystal display to indicate stroke speed of the pump and theoretical flow. Control shall be selectable between internal and external modes as well as stroke frequency adjustment by means of a tactile keypad. Adjustment for stroke length shall be by means of a readily accessible dial knob. A pulse indicator light shall flash green between strokes when pumping in internal mode, and yellow between strokes when pumping in external mode. When in external mode, Series AD8 units shall accept 4-20 mA input signal or external pulse signal for control of pump speed. The

Notes:

1. Where X = control codes 9, 8, 2.
2. Liquid End model codes ending with NI, SI, NM, SM, NU, SU, NP or SP.
3. Liquid End model codes ending with AI, HI, AM, HM, AU, HU, AP or HP.
4. Type 316 stainless steel, Hastelloy or PTFE may be specified.

pump shall be capable to support external connection requirements for remote start/stop or pulse divide/multiply functions or a power supply for remote powered devices. The pump shall be equipped with an on/off button and a dual low level float switch input. When the dual low level sensor registers empty, the low level indicator light shall turn yellow when a low level is registered and red when an empty level is registered. The pump shall turn off when it registers an empty level. The pump shall be equipped with a universal voltage supply capability.

SERIES AD9

Series AD9 metering pumps shall have a graphical display to indicate stroke speed of the pump and theoretical flow. Control shall be selectable between internal and external modes as well as stroke frequency adjustment by means of a tactile keypad. Adjustment for stroke length shall be by means of a readily accessible dial knob. The pump shall have the following control modes: Manual, mA, pulse multiply/batch accumulate, pulse divide and timer. Configuration mode settings shall allow for specific pump category settings and adjustments. A pulse indicator light shall flash green between strokes when pumping in internal mode, and yellow between strokes when pumping in external mode. When in external mode, Series AD9 units shall accept 4-20 mA input signal or external pulse signal for control of pump speed. The pump shall be capable to support external connection requirements for remote start/stop or pulse divide/multiply options or output for a power supply for remote powered devices. The pump shall be capable to support external connection capabilities for a digi-pulse or flow meter input or flow meter sensor. The pump shall be capable to support external connection for a remote internal/external input or 4-20 mA output or pacing output or alarm output. The pump shall be equipped with an on/off button and a dual low level float switch input. When the dual low level sensor registers empty, the low level indicator light shall turn yellow when a low level is registered and red when an empty level is registered. The pump shall turn off when it registers an empty level. The pump shall be equipped with a universal voltage supply capability.

DRIVE

The pump drive shall be totally enclosed with no exposed moving parts. Electronic pulser shall be supplied with quick connect terminals at least .110" wide (2.79 mm). Electronics shall be housed in a chemical resistant enclosure for maximum protection against chemical spillage. Electrical power consumption shall not exceed 25 watts per hour under full speed and maximum pressure conditions. Pump weight shall not exceed 10 lbs (4.75 kg).

PRESSURE RELIEF

The LMI 4-Function Valve installed with a FastPrime™ or AutoPrime™ Liquid End is recommended to provide automatic pressure relief.

MATERIAL

Chemical metering pump housing shall be of chemically resistant glass fiber reinforced thermoplastic. All exposed fasteners shall be stainless steel. Chemical metering pump valves shall be ball type, with ceramic balls⁴. Valves shall be serviceable by replacing the cartridge valve assembly. Pump head shall be of transparent acrylic⁵ material capable of resisting the pumped chemical. Fittings and connections at pump head shall be PVC⁶.

CHECK VALVES AND TUBING

A total of 16 ft (4.8 m) of polyethylene tubing⁷ shall be provided per pump complete with compression connections. A foot valve with integral one piece strainer shall be provided for the suction line, and an injection check/back pressure valve with ½" NPT male connection for the injection point.

5. PVDF, PVC, Polypropylene, or Type 316 stainless steel may be specified.
6. PVDF, Polypropylene, or Type 316 stainless steel may be specified.
7. 6 ft (1.8 m) of vinyl suction tubing may be specified in place of polyethylene for the suction side only. 1/4" pipe thread may be specified.



201 Ivyland Road
Ivyland, PA 18974 USA
TEL: (215) 293-0401
FAX: (215) 293-0445
<http://www.lmipumps.com>

MOUNTING INFORMATION

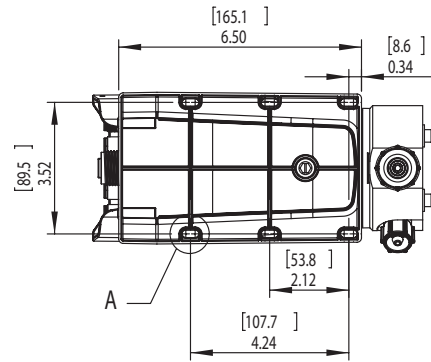
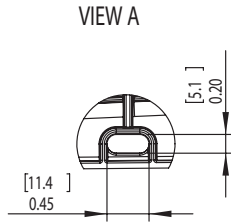

FASTPRIME LIQUID ENDS

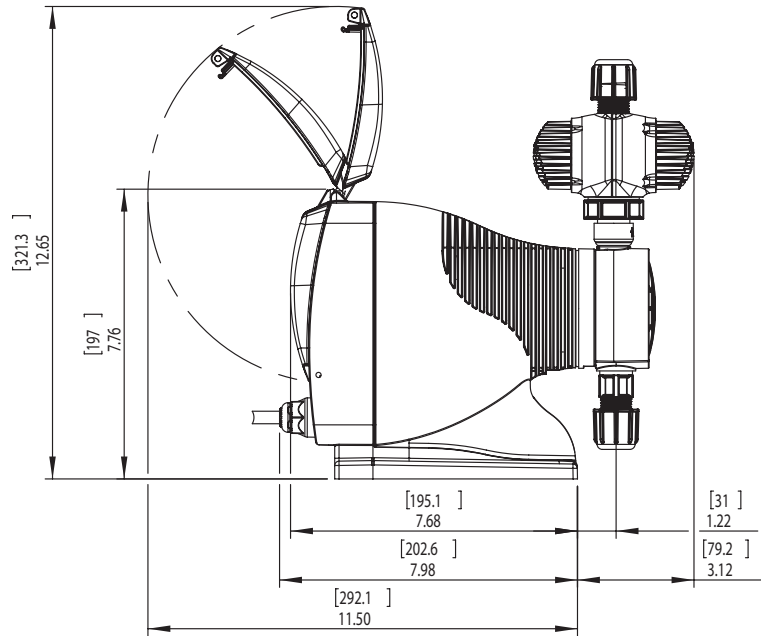
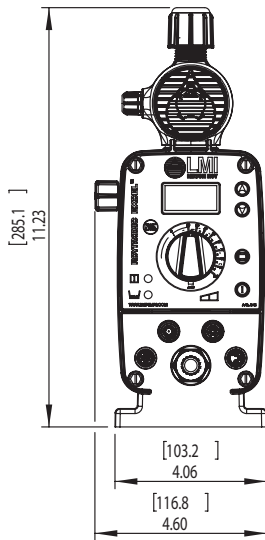

AUTOPRIME LIQUID ENDS

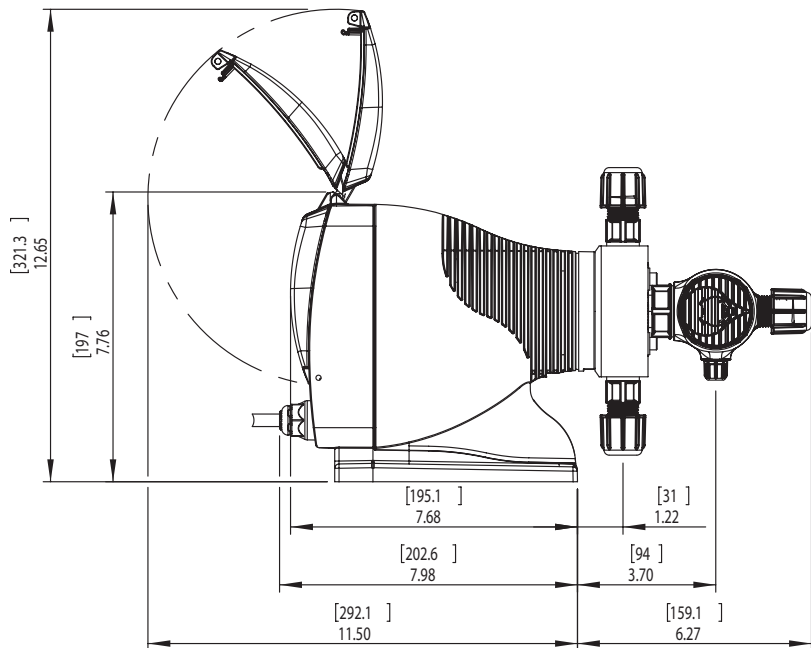
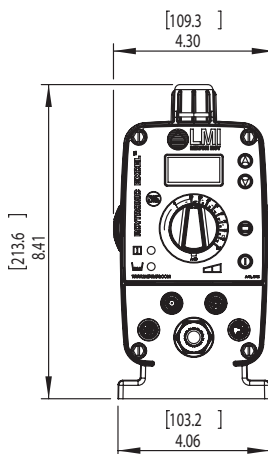

NOTE: ALL DIMENSIONS ARE IN INCHES [MM]. DIMENSIONS SHOWN ARE FOR LARGEST LIQUID END.
DIMENSIONS WILL VARY DEPENDING ON LIQUID END SELECTED.