

BRONZE CENTRIFUGAL PUMPS

CENTRIFUGAL PUMPS SERIES 815B

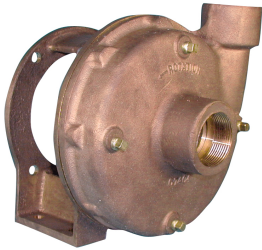

FEATURES

- Bronze Construction
- Stainless Steel Shaft
- Carbon Face Mechanical Pump Seals - Nitrile STD
- fluoroelastomer (S10) or Polytetrafluoroethylene (S11) Pump Seals Available for Solvent Transfer
- Field convertible to pedestal drive model
- Will Handle Contaminated Liquids
- Extremely Quiet
- Pump-heads only easily field mounted to standard footless "C" flange motors
- Keyless impeller option (815B-07)
- O-Ring housing seal eliminates gasket problems
- Hydraulic motor adapter available

DRIVE

This close-coupled pump uses a standard NEMA 56C motor with no base. Single phase motors are non-reversible and are wired for the proper pump rotation which is counter-clockwise looking at inlet end of pump. See the dimensional drawing. Three phase motors must be checked out for proper rotation when pump is installed. Interchanging of any 2 wires in a 3-phase system will reverse motor rotation.

LIQUIDS AND TEMPERATURE

The special pump alloys used provide corrosion resistance to many liquids including water, water solutions, and a wide range of commercial chemicals. Questions as to the chemical compatibility of special liquids should be referred to the factory.

Viscous liquids with a maximum viscosity of 2000 Saybolt Seconds Universal can be pumped. However, when pumping viscous liquids as compared with water, a reduction in flow and pressure occurs and the required horsepower rate increases. Liquids heavier than water require additional horsepower in direct proportion to the increase in specific gravity. Liquids contaminated with small solids or abrasives can be handled, but a reduction in mechanical seal life must be expected. The pump uses a mechanical type shaft seal with a nitrile rubber element. It is suitable for water, oils, and some mild solvents and it is limited to 212o F. fluoroelastomer seals and Polytetrafluoroethylene (PTFE) seals are available for severe solvents, difficult chemicals, and elevated temperatures.

PERFORMANCE

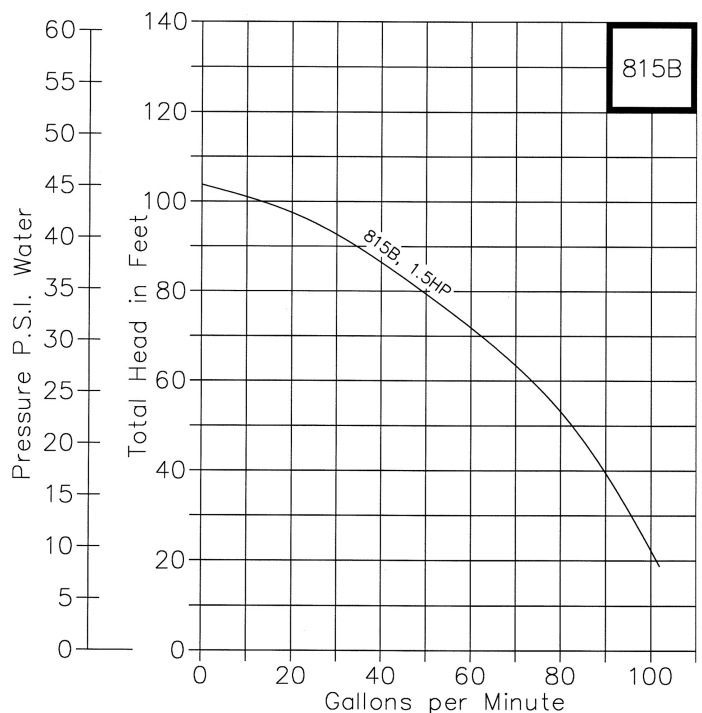

SUCTION LIFT

These centrifugal pumps are not self-priming. They must be installed below the liquid level so that the liquid flows to the pump by gravity (flooded suction). However, if a foot valve is used at the beginning of the suction line, and all air is bled from the pump by manual priming, the pump will lift on the suction side up to 15 feet. Such a system relies entirely on the non-leaking foot valve for starting capability.

EXPLODED VIEW AND PARTS LIST

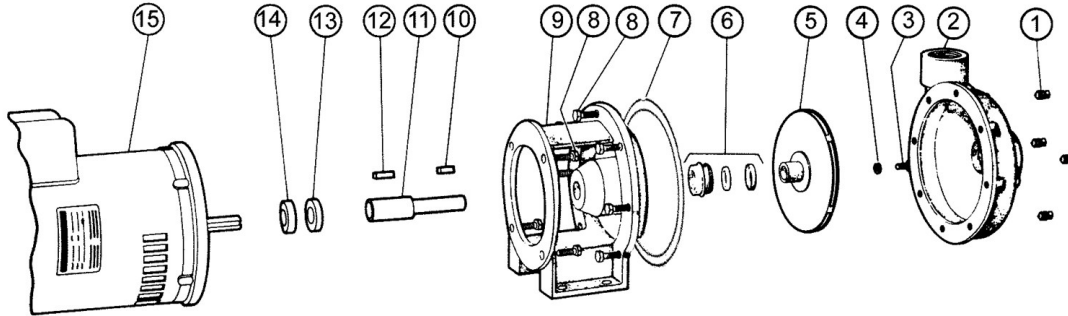

Pump No.	1	2	3	4	5 ¹	6 ¹	7 ¹	8	9	10	11	12	13	14	15	Repair Kit ¹
	Plug	Body	Screw	Lock Wash.	Impeller	Seal Assy.	Gasket	Screw	Adapter	Key	Shaft	Key	Collar	Collar	Motor	
	4 Reqd	1 Reqd	1 Reqd	1 Reqd	1 Reqd	1 Reqd	1 Reqd	12 Reqd	1 Reqd	1 Reqd	1 Reqd	1 Reqd	1 Reqd	1 Reqd	1 Reqd	
815B	5395	7585	7656	7395	32354	32346	7425	5411	7586	7428	7421	6845	5886	7658	---	10959
815B-07	5395	7585	---	---	32002	32346	7425	5411	7586	7428	2928	6845	5886	7658	---	12313

¹ Repair Kit contains items 5, 6, and 7.

DIMENSIONS

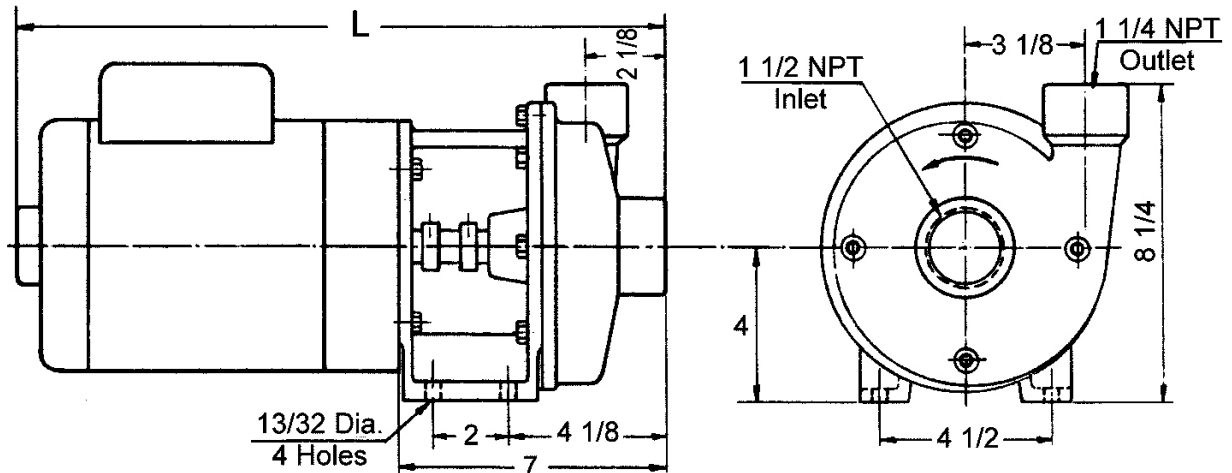

WITH MOTOR

