

2" Self-Priming High Pressure Pumps

- **Cast Iron Construction with Aluminum Impellers**
- **Viton Mechanical Seal with EPR/EPDM Check Valve and O-Rings**
- **2" NPT Suction and Discharge Ports**
- **Maximum Temperature 180°F**
- **Max Flow 122 GPM**
- **Max Head 270 Ft. (116 psi)**
- **Self-Priming to 20 ft.**
- **Closed Vane Aluminum Impeller Designed for High Pressure Performance**
- **7-1/2 to 10 HP TEFC, Single and Three Phase Motors**
- **Optional Mounting Base Available (A200-90)**



Model Shown with
A200-90 Optional
Base

AMT 2" Self Priming High Pressure Pumps are self-priming high pressure booster pumps with a two stage impeller design to provide additional pressure. All models feature cast iron construction with aluminum impellers and Viton Mechanical Seals. Built-in EPR/EPDM check valve for fast priming are standard on all units. Fill and drain plugs for easy installation and servicing. These units are self-priming up to 20 feet and are suitable for high pressure applications such as dewatering, sprinkler/booster, irrigation, and fire protection. Units are close coupled and are available in 7-1/2 to 10 horsepower TEFC electric motors.

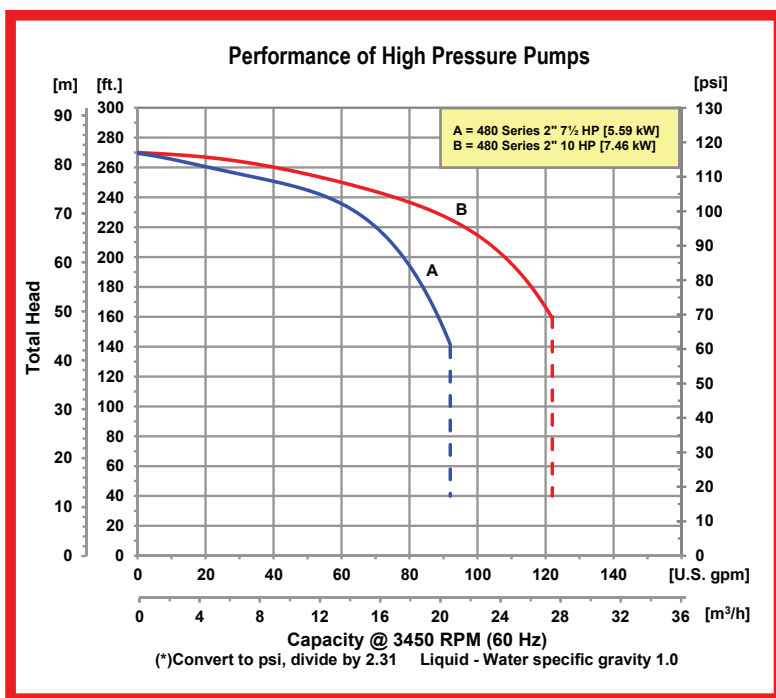

400 Spring Street • Royersford, PA 19468 USA

www.amtpump.com • 888-amt-pump (268-7867)

For use with nonflammable liquids compatible with pump component materials. Viton® and Teflon® are registered trademarks of E. I. DuPont.

Pump Dimensional & Specification Data

Model	HP	PH	SUC*	DIS*	A	B	C	D	L	W	H	Ship Wt. (lbs.)
4803-95	7.5	1	2	2	8.5 [21.6]	7.0 [17.8]	17.0 [43.2]	NA	30.5 [77.5]	15.8 [40.0]	13.6 [34.43]	222
4802-95	7.5	3	2	2	7.5 [19.1]	5.5 [14.0]	16.1 [40.9]	0.75 [1.9]	26.5 [67.3]	14.3 [36.2]	13.6 [34.43]	160
4805-95	10	1	2	2	8.5 [21.6]	7.0 [17.8]	17.0 [43.2]	NA	30.5 [77.5]	15.8 [40.0]	13.6 [34.43]	305
4804-95	10	3	2	2	8.5 [21.6]	7.0 [17.8]	17.0 [43.2]	NA	29.5 [74.9]	14.3 [36.2]	13.6 [34.43]	215

(*) Standard NPT (Female) pipe thread.

(**) This dimension may vary due to motor manufacturer's specifications.

(+) 3-Phase models can also operate on 50 Hz (This will change full load amps and service factor, RPM and priming capabilities).

NOTE: Dimensions are in inches (centimeters) and have a tolerance of $\pm 1/4"$.

NOTE: Electric supply for ALL motors must be within $\pm 10\%$ of nameplate voltage rating (e.g. 230V $\pm 10\%$ = 207 to 253).

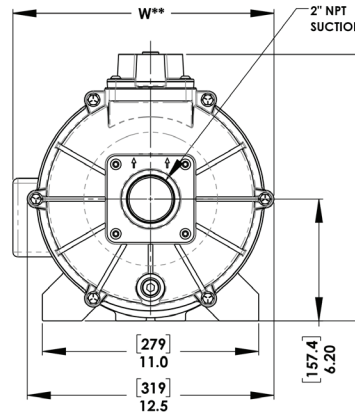
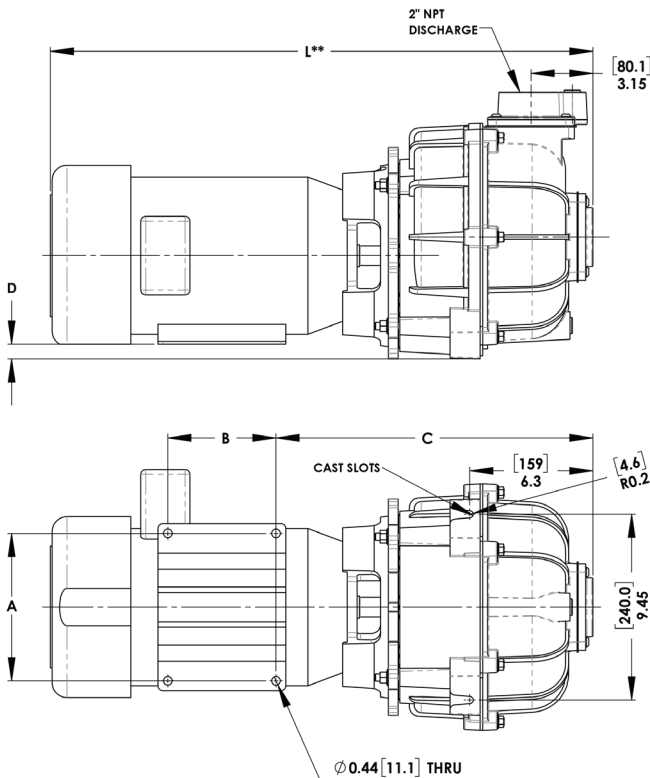

Optional Mounting Base Model A200-90

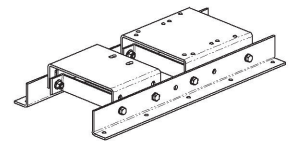

Model	HP	PH	ENC	Frame	Voltage @ 60 Hz+	Full Load Amps
4803-95	7.5	1	TEFC	215JM	230	31
4802-95	7.5	3	TEFC	184JM	208-230/460	22/11
4805-95	10	1	TEFC	215JM	230	40
4804-95	10	3	TEFC	215JM	208-230/460	26/13

Standard Features

- Cast Iron Construction with Dual Closed Vane Aluminum Impellers
- Viton Mechanical Seal w/ Silicon Carbide and Carbon Faces
- Built in EPR/EDPM Check Valve permits Self-Priming up to 20 Ft.
- Closed Vane Aluminum Impeller design for High Pressure Performance
- Fill and Drain Plugs for Easy Installation and Servicing
- 2" NPT Suction and Discharge Ports
- Maximum Temperature 180°F
- Maximum Working Pressure 150 PSI
- Max Flow 122 GPM
- Max Head 270 Ft. (116 PSI)
- 7-1/2 to 10 HP TEFC, Single and Three Phase Motors
- Optional Mounting Base Available (A200-90) available on all models
- QSP- Quick Ship Product for Many Models

Hazardous Duty/Explosion Proof Motors Available; CALL FOR QUOTATION & LEAD TIME!