

# **BALDOR® • RELIANCE**

## **Product Information Packet**

# **CSSEWDM3611T**

**3HP, 1760RPM, 3PH, 60HZ, 182TC, 3635M, TEFC, F1**

Part Detail							
Revision:	L	Status:	PRD/A	Change #:		Proprietary:	No
Type:	AC	Prod. Type:	3635M	Elec. Spec:	36WGS987	CD Diagram:	CD0005
Enclosure:	TEFC	Mfg Plant:		Mech. Spec:	36G560	Layout:	36LYG560
Frame:	182TC	Mounting:	F1	Poles:	04	Created Date:	07-13-2012
Base:	RG	Rotation:	R	Insulation:	H	Eff. Date:	02-29-2016
Leads:	9#16					Replaced By:	
Literature:		Elec. Diagram:					

<b>Nameplate NP1953B01</b>										
<b>CAT.NO.</b>	CSSEWDM3611T									
<b>SPEC.</b>	36G560S987G1									
<b>HP</b>	3									
<b>VOLTS</b>	230/460									
<b>AMP</b>	8.4/4.2									
<b>RPM</b>	1760									
<b>FRAME</b>	182TC				<b>HZ</b>	60			<b>PH</b>	3
<b>SER.F.</b>	1.15		<b>CODE</b>	K	<b>DES</b>	B		<b>CLASS</b>	H	
<b>NEMA-NOM-EFF</b>	89.5			<b>PF</b>	76					
<b>RATING</b>	40C AMB-CONT									
<b>CC</b>									<b>USABLE AT 208V</b>	8.8
<b>DE</b>	6206				<b>ODE</b>	6206				
<b>ENCL</b>	TEFC		<b>SN</b>							

Parts List		
Part Number	Description	Quantity
SA247695	SA 36G560S987G1	1.000 EA
RA234563	RA 36G560S987G1	1.000 EA
36FN3000C01	EXFN, PLASTIC, 5.25 OD, .912 ID	1.000 EA
11XW1032G06	10-32 X .38, TAPTITE II, HEX WSHR SLTD U	1.000 EA
HW3001B01	BRASS CUP WASHER, FOR #8 SCREW	1.000 EA
36FE1912A05	FREP TEFC 206 BRG (STAINLESS)	1.000 EA
RM1070A42	O-RING,(#70-7.239) VITON .070X7.239	1.000 EA
HW4600F25	AXIAL FACE SEAL AFX-30 304SS/V107 SS CAS	1.000 EA
HW4500A33	1/8 NPT STAINLESS,HOLO-KROME #13002,PRES	3.000 EA
HW5100A06	W2420-025 WVY WSHR (WB)	1.000 EA
36PE1913A03	PUEP 182-4TC ENCL 206 BRG (STAINLESS)	1.000 EA
RM1070A42	O-RING,(#70-7.239) VITON .070X7.239	1.000 EA
HW4600F25	AXIAL FACE SEAL AFX-30 304SS/V107 SS CAS	1.000 EA
HW4500A33	1/8 NPT STAINLESS,HOLO-KROME #13002,PRES	3.000 EA
RM1070A14	O-RING, -010 VITON, .250 ID, .070 C.S.	4.000 EA
51XB1214A16	12-14X1.00 HXWSSLD SERTYB	1.000 EA
36FH4007	FAN COVER #304 STAINLESS W/OUT GREASER	1.000 EA
10XN1032S06	HEX HD CAP SCREW, SS	3.000 EA
36CB4517	LIPPED CB LID #304 STAINLESS - CLEANED	1.000 EA
37GS3010	1/16"WHITE LID GASKET	1.000 EA
59XN0832S07	8/32 X 7/16 HX WS HD SER X	4.000 EA
HW2502E16	#303 SS,SQ KEY 1/4 X 1.750	1.000 EA
HA7000A02	KEY RETAINER RING, 1 1/8 DIA, 1 3/8 DIA	1.000 EA
MJ5001A27	32220KN GRAY SEALER *MIN BUY 4 QTS=1GAL	0.005 QT

<b>Parts List (continued)</b>		
<b>Part Number</b>	<b>Description</b>	<b>Quantity</b>
MJ5004A37	#76732 LOCTITE ANTISEIZE THRD COMPOUND	0.005 EA
HA5027A02	HA4054 T-DRAIN X2 BAGGED WITH LABEL	1.000 EA
HW3200S01	EYEBOLT 3/8-16 X3/4 S.S. TDR #35988	1.000 EA
MJ1000A02	GREASE, POLYREX EM EXXON (USe 4824-15A)	0.050 LB
WD5603A01	KIT, CLOSED-END LEAD SPLICE (18-14GA)	1.000 EA
HA3101S29	THRUBOLT- 1/4-20X13.00 SS	4.000 EA
G0PA1000	PKG GRP, PRINT PK1026A06	1.000 EA
MN416A01	TAG-INSTAL-MAINT no wire (1200/bx) 11/14	1.000 EA
HA5027A07	85XU1208S08 FACE DRAIN PINS BAGGED	1.000 EA

**AC Induction Motor Performance Data**

Record # 39149 - Typical performance - not guaranteed values

<b>Winding:</b> 36WGS987-R001	<b>Type:</b> 3635M	<b>Enclosure:</b> TEFC
-------------------------------	--------------------	------------------------

Nameplate Data				460 V, 60 Hz: Single Voltage Motor	
Rated Output (HP)	3			Full Load Torque	9.04 LB-FT
Volts	230/460			Start Configuration	direct on line
Full Load Amps	8.4/4.2			Breakdown Torque	34.8 LB-FT
R.P.M.	1760			Pull-up Torque	18.7 LB-FT
Hz	60	Phase	3	Locked-rotor Torque	22 LB-FT
NEMA Design Code	B	KVA Code	K	Starting Current	34.1 A
Service Factor (S.F.)	1.15			No-load Current	2.27 A
NEMA Nom. Eff.	89.5	Power Factor	76	Line-line Res. @ 25°C	3.58 Ω
Rating - Duty	40C AMB-CONT			Temp. Rise @ Rated Load	62°C
S.F. Amps				Temp. Rise @ S.F. Load	74°C
				Locked-rotor Power Factor	41
				Rotor inertia	0.326 LB-FT <sup>2</sup>

Load Characteristics 460 V, 60 Hz, 3 HP

% of Rated Load	25	50	75	100	125	150	S.F.
Power Factor	36	56	69	76	80	82	78
Efficiency	82	88.1	89.6	89.7	89.1	88.3	89.3
Speed	1790	1781	1772	1762	1751	1738	1755
Line amperes	2.47	2.88	3.47	4.18	4.96	5.84	4.65

Performance Graph at 460V, 60Hz, 3.0HP Typical performance - Not guaranteed values

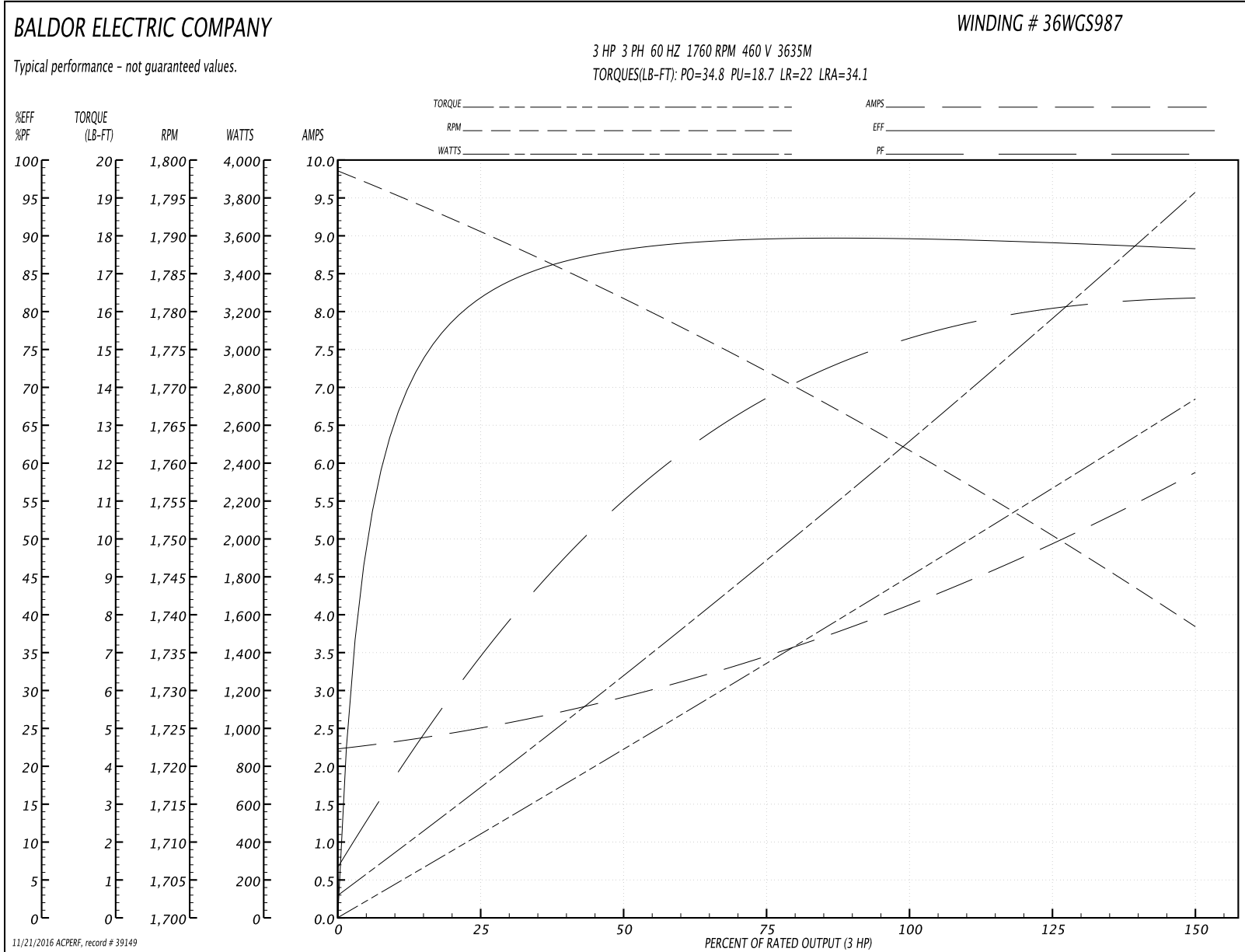

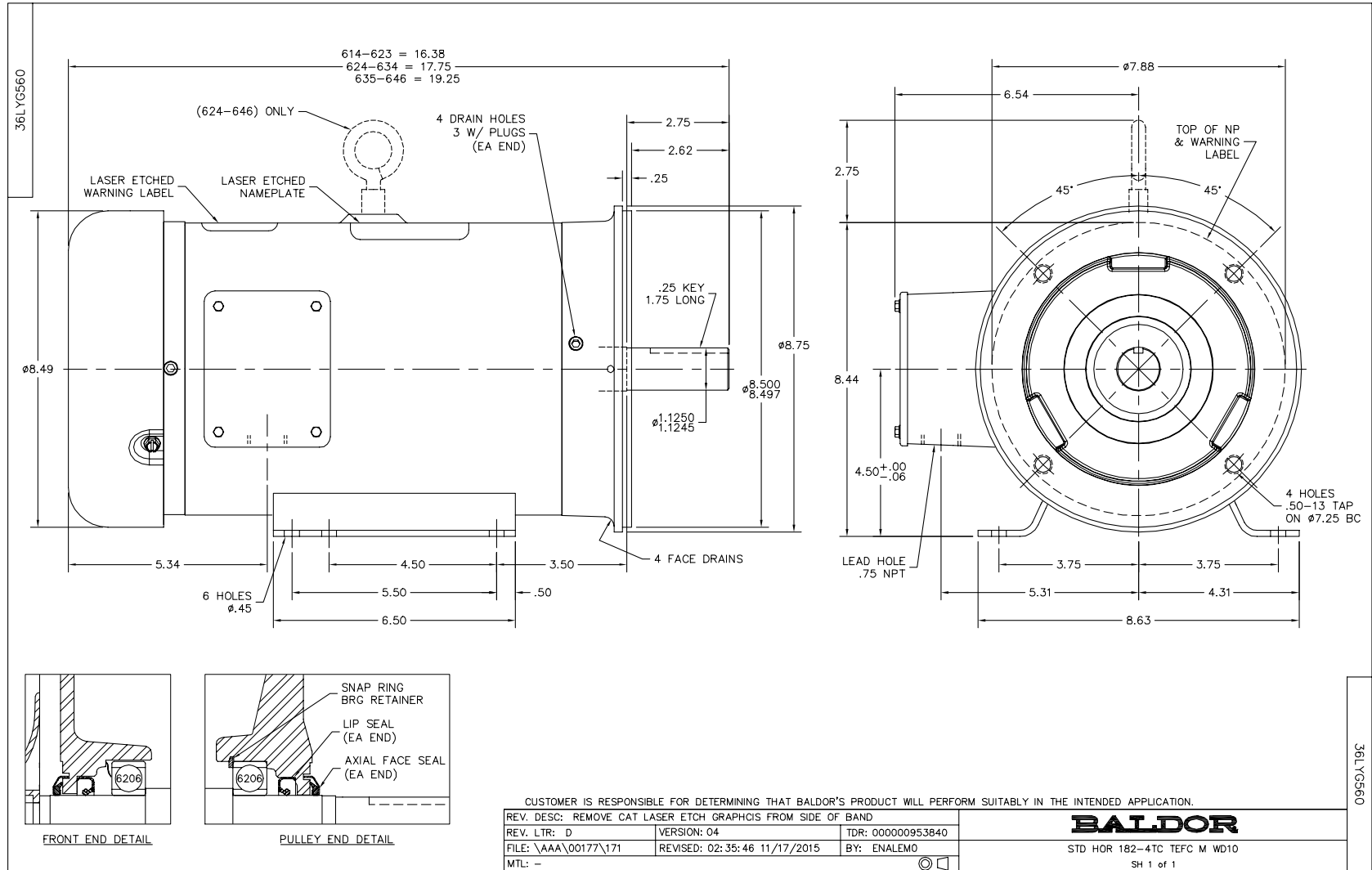

CD0005

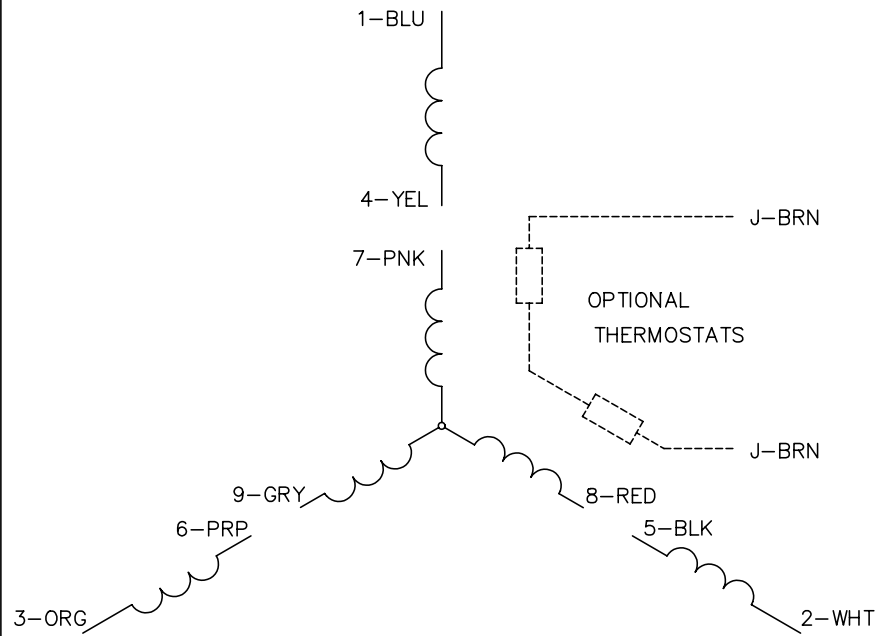

LOW VOLTAGE  
(2Y)



LINE

HIGH VOLTAGE  
(1Y)



LINE

NOTES:

1. INTERCHANGE ANY TWO LINE LEADS TO REVERSE ROTATION.
2. OPTIONAL THERMOSTATS ARE PROVIDED WHEN SPECIFIED.
3. ACTUAL NUMBER OF INTERNAL PARALLEL CIRCUITS MAY BE A MULTIPLE OF THOSE SHOWN ABOVE.
4. LEAD COLORS ARE OPTIONAL. LEADS MUST ALWAYS BE NUMBERED AS SHOWN.

REV. DESC: REVISE TO SHOW OPTIONAL COLORS			
REV. LTR: E	BY: JLP	REVISED: 01/19/99 10:15	TDR: 0171435
9000D		FILE: AAA00005140	MDL: -
		MTL: -	

**BALDOR ELECTRIC Co.**

3PH, DV, 9 LEADS

CD0005