

SLIDE RAIL COUPLING SRC-8

To be used with
8BSE series pumps



LOCATION

This SRC-8 is designed for wet wells, tanks, or lift stations where it is necessary to remove a pump from service and reinstall the pump without maintenance personnel entering the pit to unbolt the pump flanges.

STATIONARY ELBOW

Cast iron ASTM A-48 class 30

MOVABLE FITTING

Ductile iron ASTM A-536

GUIDERAIL CAP

Bracket: 304 stainless steel

Plugs: rubber and steel

HARDWARE

300 series stainless steel

GASKETS

Rubber

PAINT

Air dry enamel, water based.

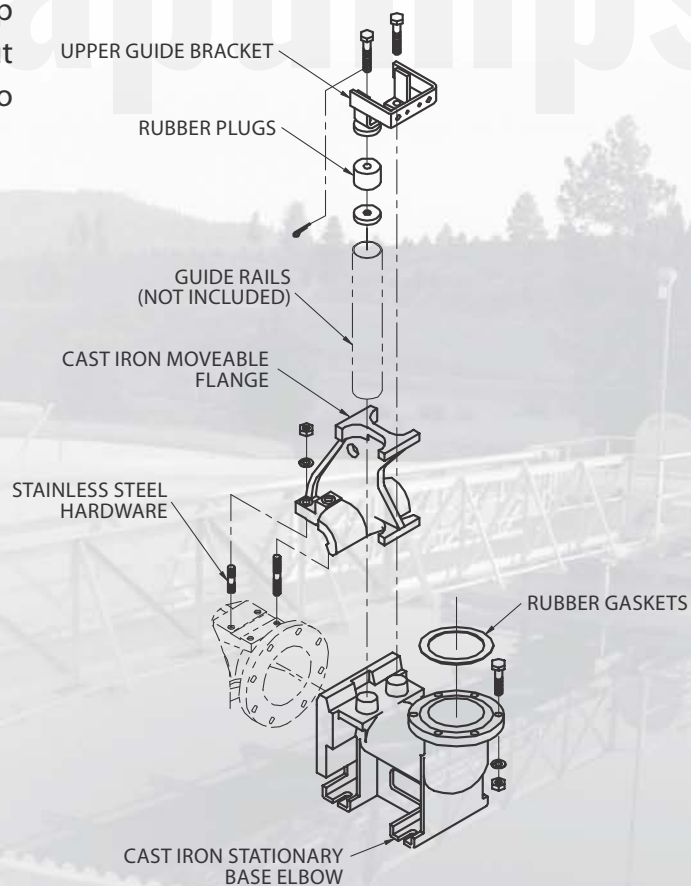

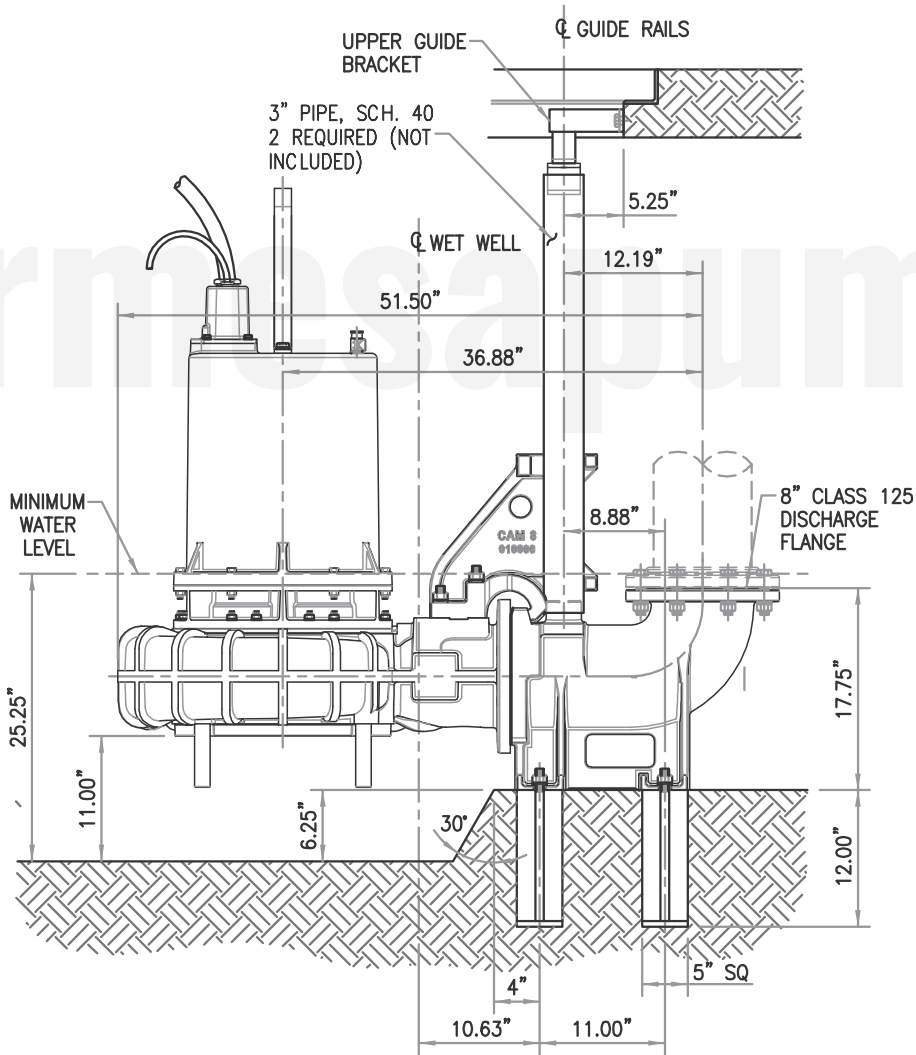
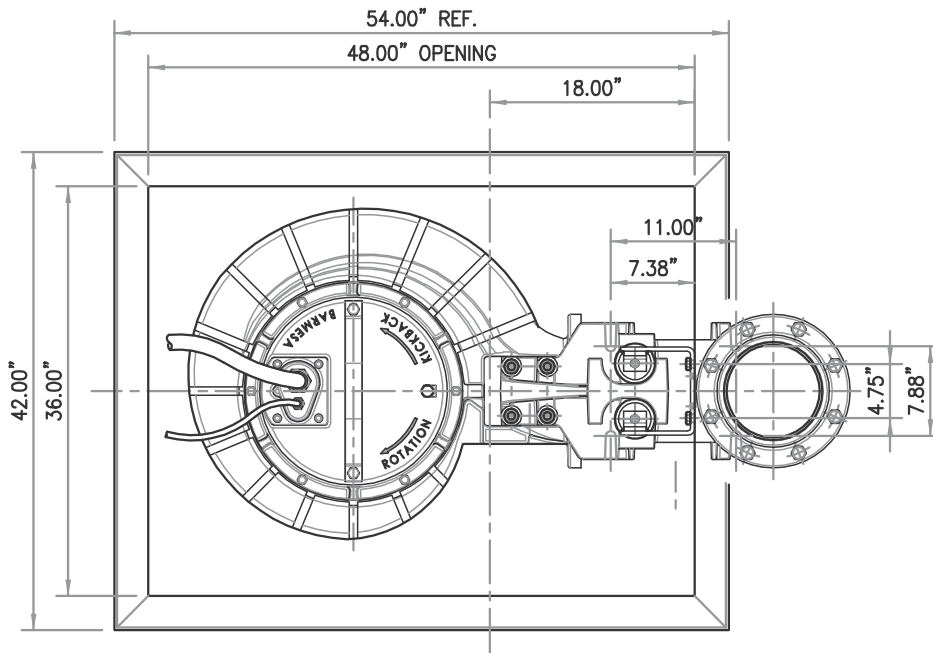

MODEL	PART No.	SIZE	RAILS	COUPLING	WEIGHT (pounds)
SRC8	62170807	8"	3"	w/ upper guide bracket	301