



Elevator Sump Pump Kits

OIL SMART - Staying dry and protecting the environment



The Oil Smart kits consist of panel, oil smart switch, liquid smart alarm sensor and pump. The setup allows water to be pumped from elevator sumps and transformer vaults without danger of pumping oil into sewers and waterways.

FEATURES

- Protects environment from hazardous waste
- The solid state device senses between oil and water
- Panel and switch kitted with effluent single phase pumps.
- Only operates pump if water is sensed by probes. Does not operate if oil is sensed by probes.

FEATURES FOR PUMP

- Effluent, 1/3, 1/2, 3/4 and 1 HP, single phase pump
- Hard faced seal
- Cast iron construction

ELEVATOR PUMP KITS

Brands	Model Number	Panel	Oil Smart Switch	Liquid Smart Sensor	Pump
GWT	ELKTWE0311L	A1SEE1 Included	Included	Included	WE0311L
	ELKTWE0511H				WE0511H
	ELKTWE0512H				WE0512H
	ELKTWE0712H				WE0712H
	ELKTWE1012H				WE1012H
B&G	ELKT2EC0311L	A1SEE1 Included	Included	Included	2EC0311L
	ELKT2EC0511				2EC0511
	ELKT2EC0512				2EC0512
	ELKT2EC0712				2EC0712
	ELKT2EC1012				2EC1012

Order Online: www.PumpCatalog.com

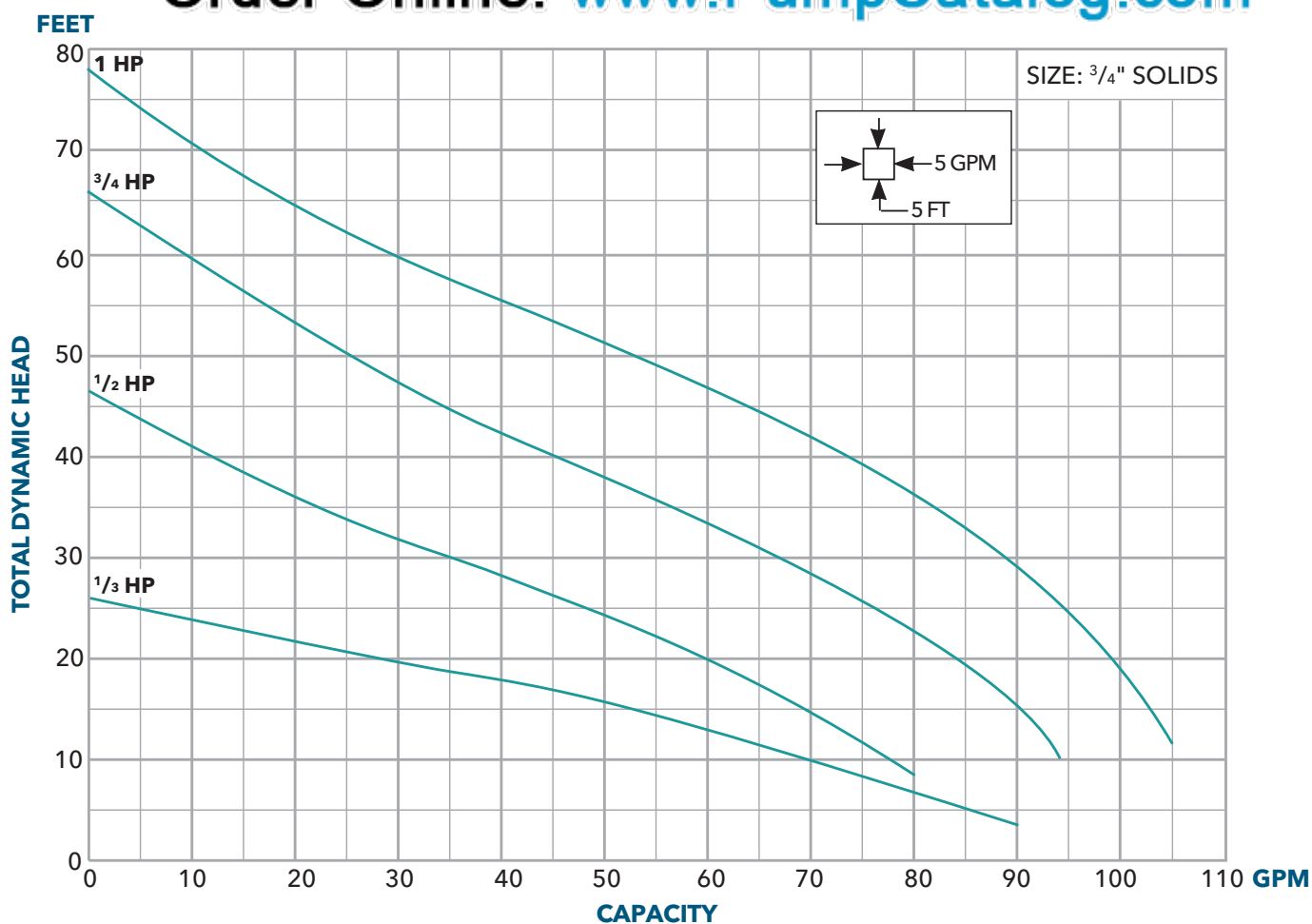

PANEL LAYOUTS

SIMPLEX SINGLE PHASE PANEL – A1SEE1

Enclosure Dimensions (in inches)

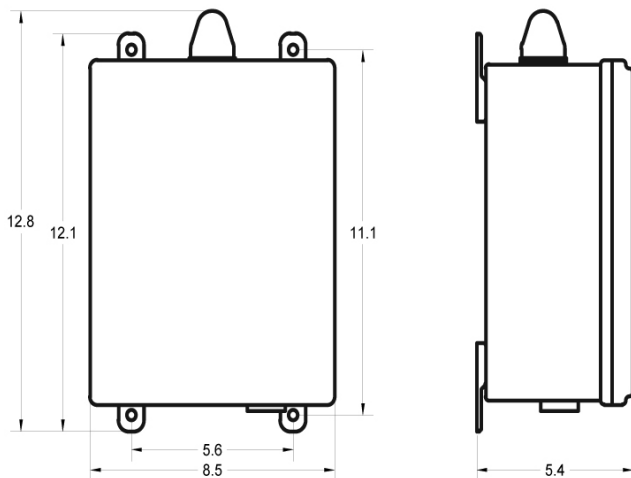

Wiring Diagram

INSIDE VIEW

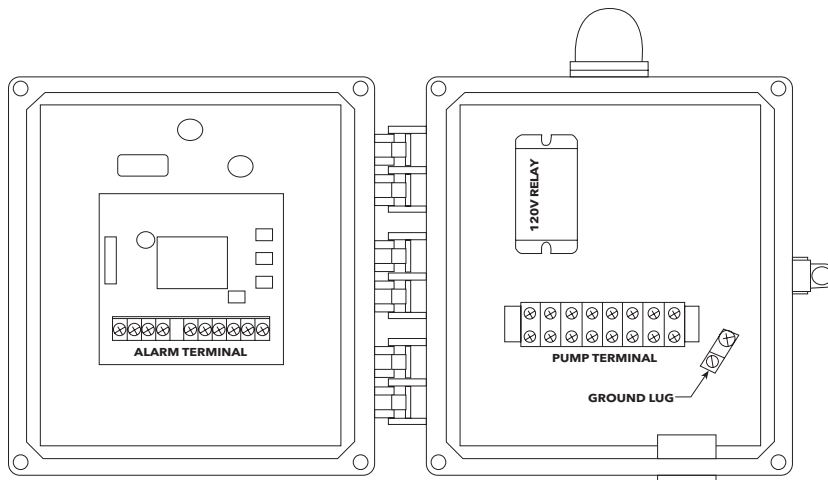

ALARM TERMINAL

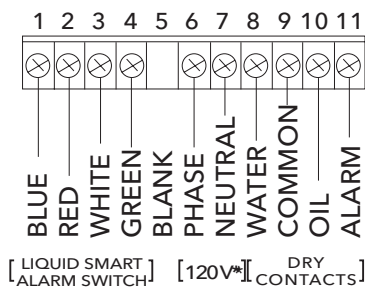

* Hook up separate 120V supply here or jump from pump terminal 1 and 3 to alarm terminal 6 and 7 for power.

PUMP TERMINAL

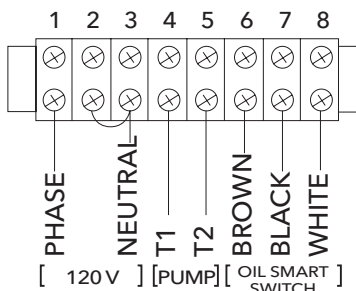

* For 240V, remove jumper and supply power to terminals 1 and 2, with neutral on 3.



Xylem |'zīləm|

- 1) The tissue in plants that brings water upward from the roots;
- 2) a leading global water technology company.

We're a global team unified in a common purpose: creating advanced technology solutions to the world's water challenges. Developing new technologies that will improve the way water is used, conserved, and re-used in the future is central to our work. Our products and services move, treat, analyze, monitor and return water to the environment, in public utility, industrial, residential and commercial building services, and agricultural settings. With its October 2016 acquisition of Sensus, Xylem added smart metering, network technologies and advanced data analytics for water, gas and electric utilities to its portfolio of solutions. In more than 150 countries, we have strong, long-standing relationships with customers who know us for our powerful combination of leading product brands and applications expertise with a strong focus on developing comprehensive, sustainable solutions.

For more information on how Xylem can help you, go to www.xylem.com



Questions? Call 1-800-810-1053



Xylem Inc.
2881 East Bayard Street Ext., Suite A
Seneca Falls, NY 13148
Phone: (866) 325-4210
Fax: (888) 322-5877
www.gouldswatertechnology.com

Goulds is a registered trademark of Goulds Pumps, Inc. and is used under license.
© 2016 Xylem Inc. OILSMSALES R2 December 2016