

M50 • L50 SERIES

Pump Manual

HORIZONTAL CLOSE COUPLED
VERTICAL CLOSE COUPLED
HORIZONTAL FLEXIBLE COUPLED

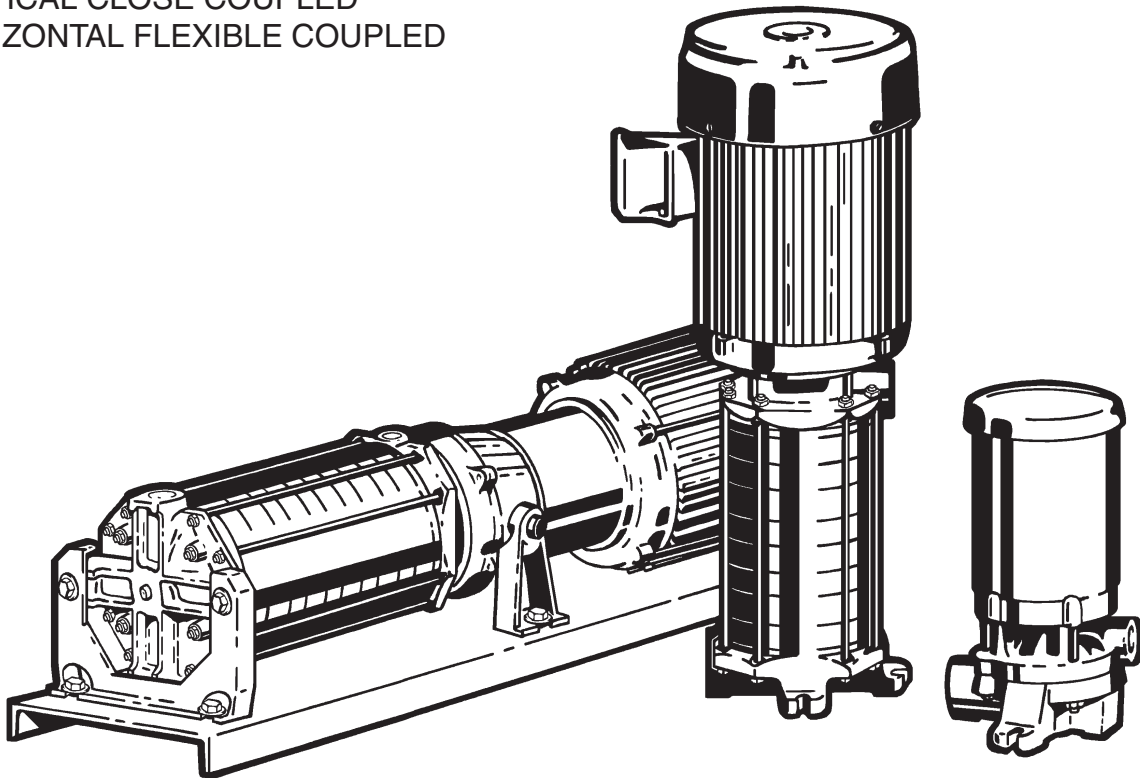

MTH PUMPS

401 West Main Street • Plano, IL 60545-1436
Phone: 630-552-4115 • Fax: 630-552-3688
Email: SALES@MTHPUMPS.COM
<http://WWW.MTHPUMPS.COM>

M50 • L50 SERIES

1. General Instructions

HORIZONTAL CLOSE COUPLED PUMPS
VERTICAL CLOSE COUPLED PUMPS
HORIZONTAL FLEXIBLE COUPLED PUMPS

- A. Inspection of Equipment
- B. Storage
- C. Placing Stored Pumps Into Service
- D. Application Considerations
- E. Recommended Spare Parts

When properly installed and given reasonable care and maintenance, regenerative turbine pumps should operate satisfactorily for many years. Because of the high differential pressures expected in a regenerative turbine pump, close running clearances are used to reduce internal losses. Abrasive particles, even microscopic ones, in high enough concentrations, can open up the close clearances between internal components. For critical services it is recommended that you keep an identical pump for stand-by use.

1A Inspection of Equipment

Immediately upon receipt of the shipment, inspect the equipment for damage or missing components. Check the shipping manifest and report any damage or shortage to the Transportation Company's local agent. Inspect the crate and any wrapping material before discarding. Parts or accessories are sometimes wrapped individually or fastened to the skid.

Put the instructions that came with the shipment in a safe place where they will be available to those who will be using them for installation and service.

1B Storage

If the pump is to be stored before use, it should be inspected as described in 1A, resealed and stored in a dry location. Standard shipping containers are not suitable for outdoor storage. In some areas, it may be necessary to cover the pump's exterior surface with oil or other rust inhibiting coating. All units are tested at the factory with a water/corrosion inhibitor solution, some of which will remain inside the pump upon receipt. If units are flushed out prior to storage, this inhibitor will be removed and proper care must be taken to prevent product deterioration from improper storage.

For storage beyond 30 days, a corrosion inhibiting protective fluid should be added to the internal pump cavities. Fluids used in the pump should be selected for compatibility with pump materials. This is very important when optional seal and gasket materials have been used. Protective caps on the inlet and outlets should also be used. Caps alone are not sufficient protection.

1C Placing Stored Pumps Into Service

Special care must be taken when placing stored pumps into service. First clean the outside and flush out the inside with a process compatible fluid. Try to turn the pump using the coupling or shaft. On close-coupled units, access to the shaft is between the pump and motor. A vise grip or other plier type gripping device may be used directly on the shaft. Applying torque to the motor fan blades is not recommended. If the impeller does not break loose immediately, fill the pump with a process compatible fluid and try again in a few hours.

If this fails, read the disassembly-reassembly instructions. With an understanding of which are the bolts used to clamp the entire assembly together, loosen each of them exactly three full turns. After filling the pump with water again, up to 50 foot pounds of torque may be applied to the coupling or shaft without fear of ruining the impeller vanes. It should begin to turn well before this force is reached. Continue turning the pump while the various fasteners are returned to their original positions.

If the unit still won't turn over, DO NOT apply further force. Refer to the Disassembly/Reassembly Instructions in Section 5 to determine the cause of the problem.

1D Application Considerations

1D1 Electrical Wiring

All electrical equipment and wiring should conform to local and National Electrical Codes. Use the motor manufacturer's instructions for connecting the motor. Note the correct rotation and wiring diagrams on the assembly. Make sure the motor rotation and speed matches that required for the pump.

1D2 Construction Materials

While it is reasonable to assume that good judgement has been used in selecting all the materials in the pump for compatibility with process fluids, actual conditions sometimes vary from original specifications. Also, typical material selection charts do not consider all the temperature, pressure, and fluid variables. The customer's engineer should be consulted for final judgement on the best materials for critical process applications.

1D3 Valves

The first valve to be considered for a regenerative turbine pumping system might be a pressure relief valve. Because this type of pump has a horsepower requirement similar to that of a positive displacement pump (constantly rising hp along with pressure increases) a relief valve can be effectively used to limit horsepower. This is helpful when a non-overloading motor is specified. It can be of critical importance if the system flow rate can vary widely. There are almost no circumstances where a flow modulating valve will work successfully in a regenerative turbine pumping system. The steep pumping characteristic, typical of these pumps, produces very large pressure changes with small variations in flow rate. As a result, the modulating flow from the valve introduces sharp pressure shock waves that shorten pump life and may cause damage to other pieces of equipment in the system.

A swing check valve is recommended in the suction line even when the pump inlet is only slightly higher than the fluid source. It should be the same size as the pump inlet or sized based on reasonable fluid friction losses.

A foot valve is recommended when lifting fluid from a sump. This will save wear and tear on any pump, even those equipped with self priming capability.

A Y-Strainer is recommended immediately ahead of the pump on any newly constructed system. This is advisable due to the probability that foreign material large enough to damage pump clearances may remain even though the piping has been flushed.

Valves in the outlet piping of a regenerative turbine pump should always be open as far as possible when the pump is started. This will reduce the start-up load on the pump and motor. Never start the pump with the discharge valve closed.

Inlet valving should be open when starting any pumping system. Without some fluid in the pump, it can gall and lock up the impellers. Violent pump failure will result from continued operation with the inlet valve closed.

1D4 Priming

Regardless of whether self-priming equipment is used or not, always fill the pump and vent it of air before starting, for best seal and pump life. Under most circumstances, regenerative turbine pumps can be made to self-prime as long as a small amount of fluid can be recirculated through the impeller and the fluid doesn't heat up noticeably.

1D5 NPSH (Net Positive Suction Head)

The NPSH required varies with every size and capacity of pump. The NPSH required by your unit can be obtained from the performance curves or from your MTH representative.

If the NPSH available is not equal to or greater than that required by the pump, it must be increased or a different pump selected. The usual method for increasing NPSH is to raise the static head on the pump inlet, (H_s).

By definition, NPSH means: "net positive suction head" above the vapor pressure of the pumped liquid available at the centerline of the pump. It should always be given in feet of pumped liquid. The NPSH is actually a measurement of the amount of energy available in the pumped liquid to produce the required absolute

entrance velocity in the pump. If a pump requires more energy (or NPSH) than is available at a given capacity, the pressure at the inlet will fall below the vapor pressure of the pumped liquid and loss of performance will result as the liquid vaporizes.

P_s = Pressure in the suction vessel in PSIA.

P_{vp} = Vapor pressure of the pumped fluid in PSIA.

H_s = Static height of the pumped fluid above (+) or below (-) the centerline of the pump in feet.

H_f = All friction losses from the vessel to the pump in feet.

$$NPSH = 2.31 \left(\frac{P_s - P_{vp}}{\text{sp. gr.}} \right) + H_s - H_f$$

For boiling liquids, P_s and P_{vp} are equal. This item then becomes zero and can be omitted from the equation.

1D6 Noise

Regenerative turbine pumps typically produce a high pitched whine that increases in intensity as the differential pressure produced in the pump increases. While high frequency sound is attenuated more easily than lower frequencies, piping structures and the fluids in them readily transmit noise. Motors, bearings, and other rotating components add to the noise and sometimes create objectionable harmonics.

Adequate support for the inlet and discharge piping is important for noise reduction.

1D7 Freezing

When ambient temperatures drop below the freezing point of the fluid in a pump, consideration should be given to heating, insulating, or draining the pump. If you choose to drain the pump, and it will only be for a short period, first remove the drain plugs,

then drain the inlet and outlet lines. Carefully blow out the pump with compressed air to clear all internal cavities of fluid.

1E Recommended Spare Parts

FOR CRITICAL SERVICES - a duplex installation, with two identical pumping units in parallel, is the safest and many times the most cost effective choice.

FOR IMPORTANT SERVICES - a standby pump, ready for installation is advised.

Special pricing and new pump warranty is offered for factory rebuilding. Turn around time can be as short as one or two days for standard models.

FOR ROUTINE MAINTENANCE

- only the mechanical seals and a complete set of "O" ring gaskets are recommended. Should additional components show wear, they are available from stock at the factory.

FOR SERVICING A PUMP THAT DOES NOT PRODUCE RATED HEAD - mechanical seals, "O" ring gaskets, impeller, and channel rings.

FOR REBUILDING A PUMP - all the components required for servicing, plus bearings, shaft, and drive keys for flexible coupled pumps, should be obtained. A factory rebuild should be considered whenever your disassembly indicates rebuilding is necessary, as this is usually more economical.

The factory recommendation for spare parts are all of those listed for rebuilding a pump, and are shown on the exploded view drawings for each individual type of pump.

M50 • L50 SERIES

2. Installation

FLEXIBLE COUPLED PUMPS
CLOSE COUPLED PUMPS

- A. Location
- B. Foundation
- C. Leveling
- D. Alignment

- E. Piping
- F. Typical Installation

In order to insure that pumping equipment is installed properly and to obtain reliable pump operation, it is recommended that only

experienced, qualified erecting engineers undertake this task. Read the instructions thoroughly before beginning.

2A Location

The first consideration for locating a pump is elevation. The lowest possible elevation using the shortest possible suction piping is usually the best. Questions regarding possible locations should be resolved by making inlet head calculations including all friction losses. The one producing the highest inlet pressure should be selected. One reason for this precaution is that, the greater the inlet pressure, the less likelihood of NPSH problems. Also, a flooded suction is particularly helpful on start-up when the seals or the entire pump can be ruined because it is not properly primed and purged of air.

A dry, easily accessible location is also important. Allow ample clearance around the unit for free air circulation. If a dry location is not available, the pump can be mounted on a foundation, above the floor. Specify motor enclosure, pump materials, or coatings to suit the worst conditions expected. Place the pump so that it can be easily inspected and serviced during operation. Sufficient head room should be provided, particularly when lifting devices will be used for heavier assemblies.

2B Foundation

Baseplates alone are not rigid enough to maintain alignment of the unit. The pump foundation is used as a support for the baseplate to maintain alignment of the unit. If the baseplate is to be grouted to the foundation, it is only necessary to embed the edges. It is unnecessary to completely fill under the baseplate. DO NOT grout the unit to the foundation until it has been properly aligned.

The foundation must be a permanent rigid installation of concrete or other material of sufficient mass to absorb

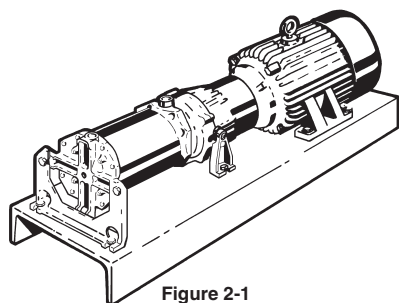

Figure 2-1

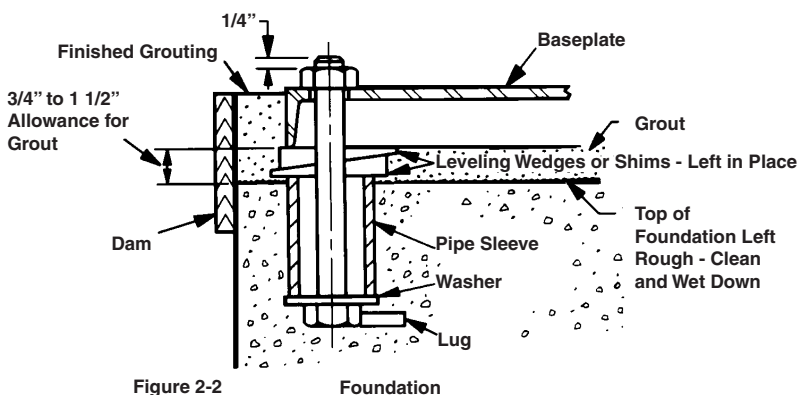

Figure 2-2 Foundation

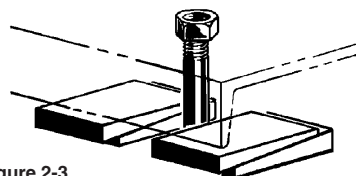

Figure 2-3

all normal vibrations. Locate the foundation bolts using a layout or template in relation to the suction and discharge piping. If concrete is being used, foundation bolts of the specified size can be enclosed in a pipe sleeve two to three diameters larger than the bolts to compensate for minor variations in alignment.

Close coupled pumps can be mounted on a steel base prior to installation or mounted directly to the foundation. Place shims under one or more of the motor feet so that strain and distortion will not result when the mounting bolts are tightened.

2C Leveling (Flexible Coupled Pumps Only, Refer to Figure 2-1)

If the unit is received with the pump and motor mounted on the baseplate:

1. Place the unit in position.
2. Disconnect the coupling halves. Do not reconnect until all alignment procedures have been completed.
3. Support the baseplate on metal shims or wedges having a small taper. (Refer to Figure 2-2)
 - a. Place shims close to the foundation bolts. (Refer to Figure 2-3)
 - b. Also place shims close to where the greatest weight is located.

4. Check the baseplate for distortion:
 - a. Place a straightedge along the baseplate to determine if it is distorted.
 - b. Adjust the shims until the baseplate is not distorted.
5. Use a section of pipe to determine if the inlet and discharge openings are vertical and located properly.
6. Correct the positions, if necessary, by adjusting the shims.

2D Alignment

Although flexible coupled pumps are carefully aligned prior to crating and shipping, it is very likely that strains imposed during transit have altered the alignment. Complete the following steps after the unit has been placed on the foundation and leveled.

To check the PARALLEL alignment: (Refer to Figure 2-4)

1. Place a straightedge across the two coupling flanges.
2. Measure the maximum offset (A), Figure 2-4, at various points

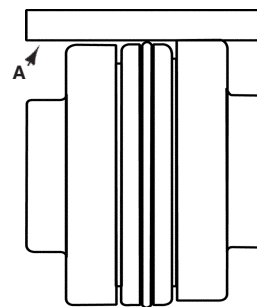

Figure 2-4

around the periphery of the coupling. DO NOT rotate the coupling.

- If the maximum offset exceeds the Parallel dimension in Chart 1 for your sleeve size, loosen the motor or pump and place thin metal shims under the motor or pump feet until the offset is corrected.

CHART 1

COUPLING TYPES JE, J, S**MAX. RPM & ALLOWABLE MISALIGNMENT**

SLEEVE SIZE	MAXIMUM RPM	PARALLEL A	ANGULAR B-C
3	9200	.010	.035
4	7600	.010	.043
5	7600	.015	.056
6	6000	.015	.070
7	5250	.020	.081
8	4500	.020	.094

- Torque down the motor or pump.
- Recheck alignment.

To check the ANGULAR alignment:
(Refer to Figure 2-5)

- Using a micrometer or caliper, measure from the outside of one flange to the outside of the other at intervals around the periphery of the coupling. DO NOT rotate the coupling.

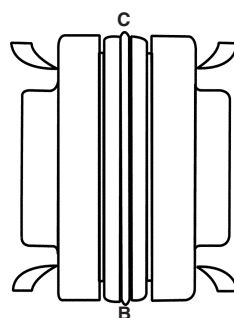

Figure 2-5

- Determine the maximum (B) and minimum (C) dimensions.
- If the difference between the maximum and minimum exceeds the Angular dimension in Chart 1 for your sleeve size, loosen the motor or pump and place thin metal shims under the motor or pump feet until the misalignment is corrected.
- Torque down the motor or pump.
- Recheck the parallel alignment above.

If the parallel or angular misalignment is great, this is an indication of baseplate distortion and must be corrected first, refer to 2C Leveling.

After all leveling and alignment operations have been completed, piping can begin. After the piping has been completed, refer to 2E1 Piping Alignment. Alignment of the unit must be rechecked to make certain

that no piping strains are causing distortion. After approximately two weeks of operation, check the alignment again to make sure that temperature changes, piping strain, or foundation variations have not caused misalignment. If alignment has been maintained over this period, the pump and motor can be doweled to the baseplate.

2E Piping**2E1 Alignment**

It is important that all piping be lined up and not forced into place. It is recommended that you begin piping at the pump. If the lines are ended at the pump, particularly if the last piece is cut a little too short or long, the pump will be forced to meet the pipe and strain or distortion will result.

2E2 Piping Support

Never allow the pump to support piping. Other means such as pipe hangers and pipe supports should be used to carry piping to avoid misalignment and distortion. Consideration should be given to thermally induced expansion and contraction, particularly in long runs of straight pipe.

2E3 Piping Size

In general, outlet and especially inlet pipe sizes should be equal to or larger than those of the pump.

M50 • L50 SERIES**3. Operation****FLEXIBLE COUPLED PUMPS
CLOSE COUPLED PUMPS**

- Rotation
- Inlet and Outlet Locations
- Foreign Material
- Electrical
- Adjustments
- Cooling Water
- Priming
- Starting
- Stopping

3A Rotation

The standard direction of rotation for the pump is right-handed, or clockwise when looking at the motor end of the pump. A rotation arrow,

refer to Figure 3-1, is located on the pump to indicate the correct direction of rotation.

Operating the pump in reverse will cause substantial performance variations and can damage the pump.

Always confirm correct motor rotation prior to connection of the coupling. If this is not possible, perform a final rotation check as follows:

- Jog the motor briefly.
- Observe rotation as the unit comes to a stop.

- Rotation should be in the direction of the arrow.

If the motor operates in the wrong direction:

- Interchange any two leads on a three-phase motor.
- On a single-phase motor, change the leads as indicated on the connection box cover. Some single-phase motors may not be reversible.

**3B Inlet and Outlet Locations
(Refer to Figure 3-1)**

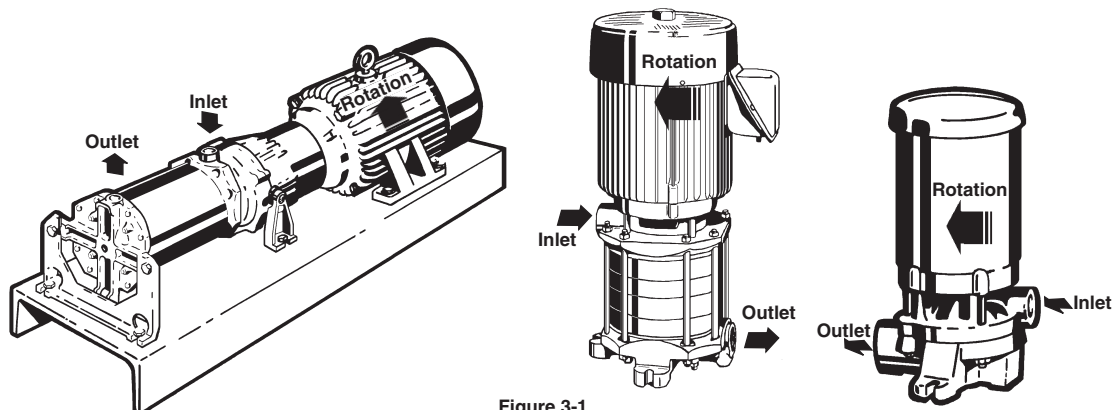

Figure 3-1

The pump inlet is located on the end nearest the motor, except on Model M51 - in which case it is farthest from the motor. The discharge or "outlet" can be on the top, side, or bottom depending on the model and construction of the pump. Normal discharge position is located on top in horizontal configurations, or in line with vertically mounted configurations.

3C Foreign Material

All regenerative turbine pumps have close running clearances in order to maintain efficiency. Take extra precautions to insure that no foreign material larger than 25 microns or .001 inches is allowed to pass through the pump. Even particles of this size can damage the pump if allowed to circulate continuously. Regenerative turbine pumps are not designed for slurries.

Large particles, weld spatter, and other material found in new piping systems will bend the impeller vanes and can sometimes lock up the pump. If a new pump does not operate properly, the first thing to check for is damage from foreign material.

3D Electrical

It is important to be aware of and follow the appropriate local and national electrical codes. Do not make wiring alterations that can affect motor rotation without reconfirming correct rotation. When making electrical connections to motors provided with threaded stud electrical terminals, the recommended torque should be 13-16 inch-lbs. Applying torque in excess of this range may cause damage.

3E Adjustments

No adjustments are necessary or advisable on new pumps other

than those required for installation. Because of the close fits in regenerative turbine pumps, it is not uncommon for the pump to be difficult to turn over by hand after the internal parts have been allowed to dry out. New pumps from the factory are tested using rust inhibitors to help preclude this possibility. On site system flushing may remove these inhibitors and subject the pump to the risk of lock up, if it is allowed to dry out. In this case, do the following:

1. Fill the pump with fluid, then wait 2 hours prior to proceeding.
2. C3 Motors/P3 Bearing Frames
 - a. Using a 5/32" Allen wrench inserted into the lock collar setscrew (#15), using the Allen wrench as a handle rotate shaft to verify there is not binding. (DO NOT LOOSEN THE SETSCREW)
 - b. Remove the Allen wrench.
 - c. Jog the pump momentarily and observe there is no binding or abnormal noise.
 - d. This should "break" the impeller loose without damage, unless foreign material has entered the pump.
3. C30 Motors/P30 Bearing Frames
 - a. Rotate the shaft to verify there is no binding. Remove the drain plug from the outlet cover and insert a 3/8" Allen wrench into the socket end of the shaft, using the wrench as a handle. If draining fluid from the pump is not practical,

use the coupling on flex-coupled units to turn the shaft. Otherwise, a vise grip or other plier-type gripping device may be used directly on the shaft between the pump and the motor.

- b. Remove the Allen wrench or pliers.
- c. Replace the drain plug and refill with fluid, if the pump was drained.
- d. Jog the pump momentarily and observe there is no binding or abnormal noise.
- e. This should "break" the impeller(s) loose without damage, unless foreign material has entered the pump.

This procedure will flush residue from the close fitting impeller surfaces. If not immediately successful, refer to Section 1, 1C Placing Stored Pumps Into Service.

Because of the large areas of close fitting surfaces inside these pumps, it takes only microscopic residue to produce resistance to rotation. Once loosened, this material is quickly dispersed and the impellers will find their hydraulic center. If these procedures are followed carefully, no damage will result from "breaking loose" the impeller.

3F Cooling Water

When the pump is used to transfer hot fluids, consideration should be given to cooling the seals and/or selecting materials that will give satisfactory seal life. The actual temperature at the seal faces, the most critical area, will always exceed the surrounding fluid temperature.

3G Priming

Pumps should not be operated unless they are completely filled with liquid. Damage to parts of the pump that depend on liquid for their lubrication can occur. Impellers can seize quickly when a pump is run dry. Without lubrication, seal faces can be damaged from heat buildup.

3H Starting

Before starting a pump for the first time, be sure that all the preceding operations have been carried out. Proper rotation, priming, and a free turning pump are most important.

1. Start the pump with the minimum possible line restriction.
2. Open discharge valves before pressing the starter.
3. Start the pump and let the system clear of air.
4. Listen for foreign material being carried through the pump.
5. Slowly close necessary valves or otherwise place the pump into service.
6. Listen for indications of undue load or other sounds indicating problems.
7. Use a clip-on ammeter to check for a steady load after approximately fifteen minutes of operation.

3I Stopping

It is best to stop the pump with the least discharge head possible both for minimizing strain on components, and to be in low power mode in anticipation of restarting.

M50 • L50 SERIES**4. Service****PUMP ENDS**

- A. Preliminary
- B. Disassembly Vertical Single Stage on C3 Motors
- C. Disassembly Multistage on C3 Motors / P3 Bearing Frames
- D. Disassembly Multistage on C30 Motors / P30 Bearing Frames
- E. Inspection of Components
- F. Reassembly Vertical Single Stage on C3 Motors
- G. Reassembly Multistage on C3 Motors / P3 Bearing Frames
- H. Reassembly Multistage on C30 Motors / P30 Bearing Frames
- I. Testing and Final Adjustments

4A Preliminary

Before attempting any service on the pump or motor, disconnect the electrical power to the motor. If the pump and motor are to be removed as a unit, note the wiring configuration, using colored or numbered tape.

1. Disconnect the inlet and outlet piping before unbolting the pump and motor.
2. Unbolt the motor from the base and remove the unit. All work on the unit should be performed on an elevated workbench whenever possible.

The disassembly and reassembly procedures are broken into eight sections covering the following units:

- B — Disassembly Vertical Single Stage on C3 Motors

- C — Disassembly Multistage on C3 Motors / P3 Bearing Frames
- D — Disassembly Multistage on C30 Motors / P30 Bearing Frames
- E — Reassembly Vertical Single Stage on C3 Motors
- F — Reassembly Multistage on C3 Motors / P3 Bearing Frames
- G — Reassembly Multistage on C30 Motors / P30 Bearing Frames

Exploded views of each unit, Figures 4-4, 4-11, and 4-12, are provided for referencing the numbers in the following procedures, i.e. (#1), motor bracket.

4B Disassembly Vertical Single Stage on C3 Motors

The following tools and equipment are needed for disassembly of C3 units.

1. Soft plastic or wooden mallet.
2. 9/16" wrench or socket.
3. 5/32" hex wrench.
4. Penetrating oil.
5. 1" wood dowel (Approx. 6" long).
6. Thin blade screwdriver.
7. Two large blade screwdrivers.

To disassemble the pump:

Refer to Figure 4-4 for reference to the numbered parts in the procedures below.

1. Remove all liquid from the pump. Air blown through the pump will remove the fluid quickly.
2. Remove the two (2) Nuts (#20) and the two (2) 3/8" X 4" Bolts

(#19) from the Cover (#2). On stainless steel models, remove the four (4) Nuts (#20).

3. Remove the cover (#2). In some cases light tapping with a plastic or wooden mallet on the outside diameter of the cover may be required to loosen it from the motor bracket. Care should be taken if a screwdriver is needed to pry between the cover and motor bracket. Damage to the "O" Ring (#7) and/or impeller can result.
4. Remove the Impeller (#11). Refer to Figure 4-1. The impeller is a slip fit and, under normal conditions, can be removed by gently tapping on the end of the shaft sleeve with a mallet. Leave the Impeller Key (#23) in place. Striking the sleeve too hard could damage the seat or rotating element.
5. Using the 5/32" hex wrench, loosen the Set Screws (#15) in the Locking Collar (#14), located on the shaft sleeve between the motor bracket and the motor face.

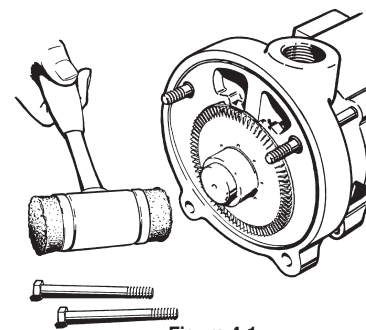

Figure 4-1

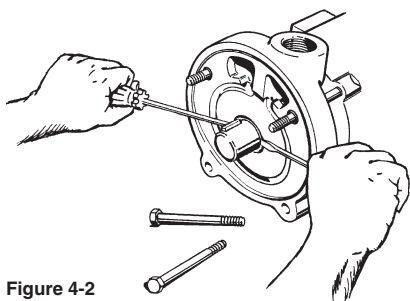

Figure 4-2

The collar should now be loose on the sleeve. Note the condition of the setscrews in the collar and replace if necessary.

6. Remove the Shaft Sleeve (#17). The sleeve is a keyed fit and is removed using two large screwdrivers. Refer to Figure 4-2.
 - a. Insert the blades of the screwdrivers between the spring holder on the rotating element and the shoulder of the shaft sleeve.
 - b. Holding the screwdrivers at approximately 3 o'clock and 9 o'clock, push the handles in toward the motor body, using the motor bracket for leverage.
7. In some cases a rocking motion of the screwdrivers will be necessary to break the sleeve loose. Normally the rotating element will slide off with the sleeve. DO NOT attempt to remove the sleeve by rotating it. (Previous models have used a threaded shaft and different procedures are required in these cases.)
8. Remove the Seal Rotating Element (#12) from the sleeve. Refer to Figure 4-3. The element normally adheres tightly to the sleeve and some force may be necessary to remove it. This is common and if care is taken, the element can be reassembled and reused. **It is recommended that a new rotating element be used for reassembly.** DO NOT

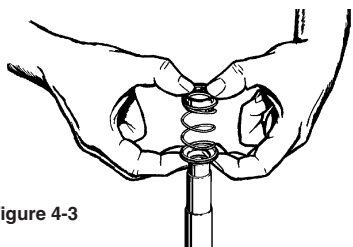

Figure 4-3

attempt to remove the seal using a screwdriver or other sharp object. Extensive damage to the shaft, sleeve, or element could occur.

9. Before the motor bracket (#1) can be removed, the four (4) "O" rings (#8), located on the upper left and right studs must be removed.
 - a. Gently tap on the back of the motor bracket, alternately between the left and the right side, until the motor bracket moves approximately 1/4".
 - b. Tap the motor bracket face to move it back to its original location.
 - c. Remove the "O" rings by sliding them off the studs.
 - d. Slide the motor bracket straight off. Do not attempt to remove the motor bracket without first removing the "O" rings (#8).
10. Remove the Seal Stationary Seat (#125). Refer to Figure 4-5.

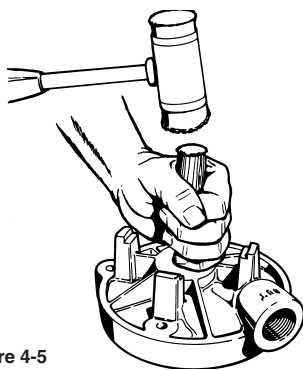

Figure 4-5

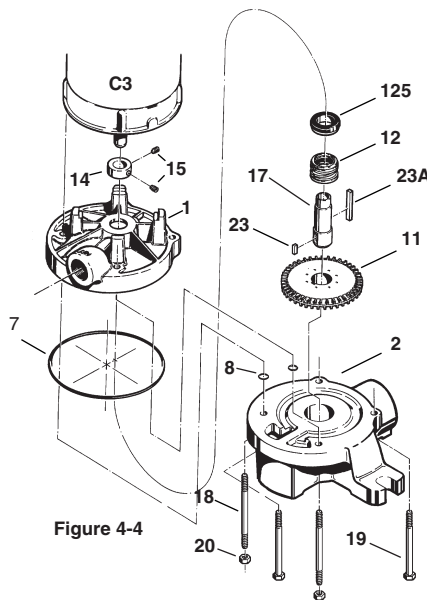

Figure 4-4

- a. Place the motor bracket face down on a flat surface.
- b. Looking into the opening in the center of the bracket, you will see a portion of the seat.
- c. Insert the 1" dowel and, very gently, tap the seat until it drops out.
- d. Care must be taken with the seats. They are a brittle material and are prone to breakage. **It is recommended that a new replacement seat be installed during reassembly.**

3. Repeat step 2 to remove the other bearing. Good support used on the inner races will prevent bearing damage.

4C Disassembly (P30)

Disassemble pump components as shown in Section 4, M50 • L50 PUMP ENDS, 4E Disassembly Multistage on C30 Motors / P30 Bearing Frames.

The following tools and equipment are needed for disassembly of the P30 units:

1. Plastic or wooden mallet
2. Arbor press or vise
3. Thin blade screwdriver
4. Adjustable spanner wrench
5. 3/8" Hex wrench
6. 7/16" Wrench or socket
7. Gear puller
8. Penetrating oil

When installing or removing bearings from the shaft, the use of an arbor press is strongly recommended.

C3 VERTICAL MOUNT PUMP

NAME/DESCRIPTION	PART NO.	QTY.
Motor Bracket	1	1
Cover/Vertical	2	1
"O" Ring/Casing	7	1
"O" Ring/Guide Rod	8	4
Impeller	11	1
Seal Rotating Element	12	1
Seal Stationary Seat	125	1
Lock Collar/Sleeve	14	1
Setscrew/Lock Collar	15	2
Shaft Sleeve	17	1
Guide Rod (Qty. 4 on S.S.)	18	2
Thru Bolt (Qty. 0 on S.S.)	19	2
Nut (Qty. 4 on S.S.)	20	2
Plug/Drain	22	1
Key/Impeller Drive	23	1
Key/Sleeve Drive	23A	1

To disassemble the pedestal:

Refer to Figure 4-28 for reference to the numbered parts in the procedures below.

1. Remove Bearing Frame Mounting Brackets (#31) by unscrewing Shoulder Screws (#33C) with a 3/8" hex wrench.
2. Remove the four (4) Hex Capscrews (#33B) that hold the Bearing Frame Housing (#3) to the End Bell (#101), using a 7/16" wrench or socket.
3. Position assembly horizontally on workbench. Holding bearing frame housing firmly, tap on the coupling end of shaft with rubber mallet until the assembly comes apart.
4. Remove guide rod nuts and guide rods from end bell.
5. Remove Outboard Bearing (#24A) using a gear puller.
6. With a spanner wrench, unscrew the Outboard Bearing Adjusting Nut (#110A) from the end bell.
7. Support end bell, with motor mounting face up, and press out shaft / bearing assembly with arbor press. Remove Inboard Bearing Adjusting Nut (#110).
8. Disengage bearing lockwasher tang from slot in Bearing Locknut (#38), using a thin blade screwdriver. Locknut and Bearing Lockwasher (#39) may now be removed from shaft. Grip shaft in the area between the two bearing surfaces only.
9. Place shaft / bearing assembly in arbor press and remove the Inboard Bearing (#24).

4D Inspection of Components

Thoroughly clean all parts. All components should be examined for wear and corrosion. Replace any parts showing visible wear.

Check to be certain that a press fit still exists between the shaft and the bearings. New bearings, or at least cleaned and regreased bearings, are recommended.

Check the shaft for galling, pitting, and corrosion. Surface corrosion on the pump portion of the shaft must be removed so the seals will slide freely during assembly. The shaft diameter should be no smaller than .002" below the nominal fractional seal sizes. Remove any nicks or burrs which may have occurred during disassembly. Reclean parts as necessary.

4E Reassembly (P3)

All parts should be visually inspected and cleaned or replaced as outlined in 4D above. It is recommended that the bearings be replaced any time the bearing pedestal is disassembled for service.

The following tools and equipment are needed for reassembly of P3 units:

1. Arbor press
2. Rubber or plastic mallet
3. Internal snap ring pliers
4. 3/4" X 6" piece of water pipe

To reassemble the bearing frame:

Refer to Figure 4-24 for reference to the numbered parts in the reassembly below.

1. Using an arbor press, install the bearings on the shaft prior to installing the shaft into the pedestal. A steel "donut" with the proper inside diameter and outside diameter, refer to Chart 1, should be used between the

Proceed to section 4E Inspection of Components.

4C Disassembly Multistage on C3 Motors / P3 Bearing Frames

The following tools and equipment are needed for disassembly of C3 / P3 units.

1. Soft plastic or wooden mallet.
2. Two 9/16" wrenches or sockets.
3. 5/32" hex wrench.
4. Side cutters (for removing keys).
5. 1" wood dowel (Approx. 6" long).
6. Thin blade screwdriver.
7. Two large blade screwdrivers.
8. Penetrating oil.

To disassemble the pump:

Refer to Figure 4-11 for reference to the numbered parts in the procedures below.

1. Remove all liquid from the pump. Air blown through the pump will remove the fluid quickly.
2. Lay the pump on the workbench horizontally.
3. Remove the four (4) Nuts (#20) from the Guide Rods (#18).
4. Remove the eight (8) Nuts (#20) from the Thru-Bolts (#19) located on the inlet cover (#1 or 11N). Pull out the thru-bolts.
5. Using a soft mallet, loosen the Outlet Cover (#2) by tapping lightly around the outside edge. Slip the cover off the Guide Rods (#18), being careful not to bend them.
6. Do not remove the Plain Bearing (#87) from the outlet cover unless it is worn. This bearing is a press fit and cannot be removed without being damaged.
7. Remove the four (4) Guide Rod "O" Rings (#8).
8. Mark on the outside surface of the Channel Rings (#9 & #10) such that the top to bottom relationship as well as the order is maintained. Number stamps are preferable to less permanent markings that tend to be lost during cleaning.
9. Separate the first Channel Ring (#9) by gently tapping the ring around the outside edge with a soft mallet and slide it off the guide rods, exercising care to prevent damage. Should prying be necessary, it should be done evenly and with great care.
10. Remove the Interstage Bushing (#16) from the Channel Ring (#9) just removed.
11. Remove the next Channel Ring (#10) using the same care as with the first. The Impeller (#11) will come off along with the channel ring. Do not attempt to pry the impeller off first, as prying will damage the impeller vanes. Hold

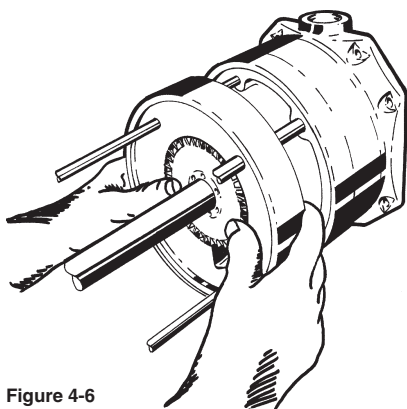

Figure 4-6

the impeller in place when it reaches the end of the shaft so it does not fall. Refer to Figure 4-6.

12. Remove the Impeller Key (#23).
13. Remove the remaining channel rings, impellers, keys, and interstage bushings. Stacking the parts as they are removed will help in maintaining the proper orientation. It is important to keep the impellers with the same pair of channel rings.

You may find it easier to disassemble the pump further by standing the pump up on the motor end when there are fewer stages on the pump.

For standard pumps (M50 Series), skip to step 16.

14. For inducer pumps (L50 Series), remove the Inducer Ring (#86IN).
15. Remove the inducer impeller.

- a. Remove the Snap Ring (#14A) at the impeller hub. A small pocket screwdriver will aid in removal. Refer to Figure 4-7.

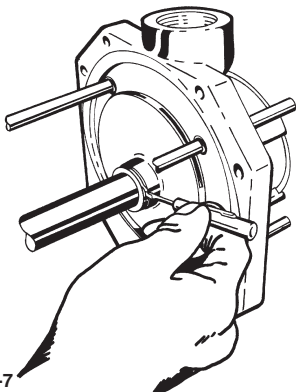

Figure 4-7

- b. Remove the Inducer Impeller (#11IN) from the shaft. The snap ring on the other end of the impeller can be left on the shaft.

16. Remove the four (4) Guide Rods (#18). If the guide rods will not turn by hand, two of the Nuts (#20) can be jammed against each other on the guide rod and a wrench can then be used to loosen them.
17. Using the 5/32" hex wrench, loosen the Setscrews (#15) in the Drive Collar (#14) located on the shaft between the inlet cover and the motor face. The collar should now be loose on the shaft.
18. Remove the Shaft (#17) and Inlet Cover (#1 or #1IN). The shaft is a keyed fit and is removed using two large screwdrivers. Refer to Figure 4-8.

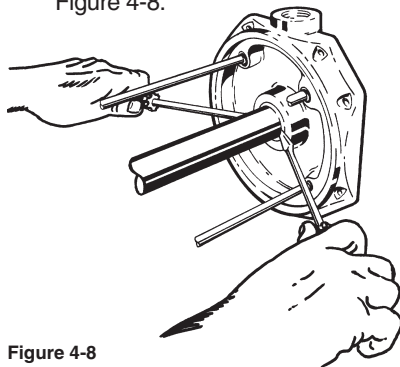

Figure 4-8

- a. Insert the blades of the screwdrivers between the springholder on the rotating element and the shoulder of the shaft.
- b. Holding the screwdrivers at approximately 3 o'clock and 9 o'clock, push the handles in toward the motor body, using the inlet cover for leverage.
- c. In some cases, a rocking motion of the screwdrivers will be necessary to break the shaft loose. The inlet cover should also come off at this time.

19. Remove the Seal Rotating Element (#12) from the shaft. Refer to Figure 4-9. The element normally adheres tightly to the shaft, and some force may be necessary to remove it. This is common, and if care is taken,

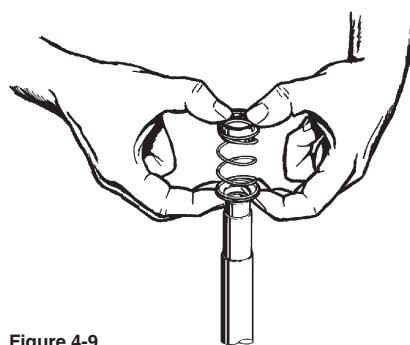

Figure 4-9

the element can be reassembled and reused. **It is recommended that a new rotating element be used for reassembly.** DO NOT attempt to remove the seal using a screwdriver or other sharp object. Extensive damage to the shaft or element could occur.

20. On inducer pumps (L50 Series), the Seal Driver (#88) can be removed from the shaft if it needs to be replaced.
21. Remove the Seal Stationary Seat (#125). Refer to Figure 4-10.

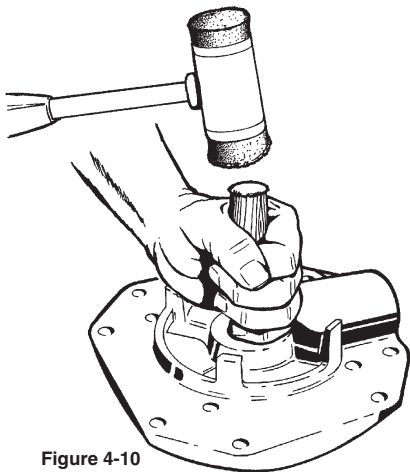

Figure 4-10

- a. Place the inlet cover face down on a flat surface.
- b. Looking into the opening in the center of the inlet cover, you will see a portion of the seat.
- c. Insert the 1" dowel, and very gently, tap the seat until it drops out.
- d. Care must be taken with the seats. They are a brittle material and are prone to breakage. It is recommended that a new replacement seat be used during reassembly.

22. It is not necessary to remove the Locking Collar (#14) from the motor shaft unless motor repairs are planned. Note the condition of the setscrews in the collar, and replace if necessary.

Proceed to section 4E Inspection of Components.

4D Disassembly Multistage on C30 Motors / P30 Bearing Frames

The following tools and equipment are needed for disassembly of C30 / P30 units.

1. Soft plastic or wooden mallet
2. Two 9/16" wrenches or sockets
3. 3/4" wrench or socket
4. 3/8" hex wrench
5. 1" wood dowel (Approx. 6" long)
6. Thin blade screwdriver
7. Two large blade screwdrivers
8. Side cutters (for removing keys)
9. Penetrating oil
10. Adjustable spanner wrench
11. 7/16" wrench or socket

To disassemble the pump:

Refer to Figure 4-12 for reference to the numbered parts in the procedures below.

1. Remove all liquid from the pump. Air blown through the pump will remove the fluid quickly.
2. Place pump horizontally on workbench.
3. Remove the four (4) nuts (#20) from the guide rods (#18).
4. Remove the eight (8) nuts (#20) from the thru bolts (#19) located on the inlet cover (#1 or #1IN). Pull out the thru bolts.
5. Using a soft mallet, loosen the outlet cover (#2) by lightly tapping around the outside edge. Slip the cover off the guide rods (#18), being careful not to bend them.
6. Do not remove the plain bearing (#87) from the outlet cover unless it is worn. This bearing is a press fit and cannot be removed without being damaged.
7. Remove the four (4) guide rod "O"rings (#8).

8. Mark on the outside surface of the channel rings (#9 & #10), such that the top to bottom relationship, as well as the order is maintained. Number stamps are preferable to less permanent markings that tend to be lost during cleaning.

9. Separate the first channel ring (#9) by gently tapping the ring around the outside edge with a soft mallet. Slide the channel ring off the guide rods, exercising care to not damage the guide rods. Should prying be necessary, it should be done evenly and with great care.

10. Remove the interstage bushing (#16) from the channel ring (#9) just removed.
11. Remove the next channel ring (#10) using the same care as with the first. The impeller (#11) will come off along with the channel ring. Do not attempt to pry the impeller off first, as prying will damage the impeller vanes. Hold the impeller in place when it reaches the end of the shaft so it does not fall. Refer to Figure 4-6.

12. Remove the impeller key (#23)

13. Remove the remaining channel rings, impellers, keys, and interstage bushings. Stacking the parts as they are removed will help in maintaining the proper orientation. It is important to keep the impellers with the same pair of channel rings.

You may find it easier to disassemble the pump further by standing the pump up on the motor end when there are fewer stages on the pump.

For standard pumps (M50 Series), skip to step 16.

14. For inducer pumps (L50 Series), remove the inducer ring (#86IN).

15. Remove the inducer impeller.

- a. Remove the snap ring (#14A) at the impeller hub. A small pocket screwdriver will aid in removal. Refer to Figure 4-7.

- b. Remove the inducer impeller (#11IN) from the shaft. The snap ring on the other end of the impeller can be left on the shaft.

16. Separate tapered pump shaft from adapter shaft or bearing frame shaft.

- a. Remove fan shroud from close-coupled models or remove the coupling guard from models on a bearing frame.

- b. Insert a 3/8" hex wrench through the drain hole and into the socket in the end of the pump shaft.

- c. Using a 9/16" or 3/4" (depending on motor frame size) wrench or socket, loosen, but do not remove, the motor draw bolt (#120) or bearing frame thru bolt (#33D).

- d. Tap sharply on the nut or head on the end of the thru bolt to separate the tapers of the two shafts, taking care not to damage the threads on the bolt.

17. Remove the motor draw bolt (or bearing frame thru bolt) completely and remove the Shaft (#17).

18. Remove the Seal Rotating Element (#12) from the shaft. Refer to Figure 4-9. The element normally adheres tightly to the shaft, and some force may be necessary to remove it. This is common, and if care is taken, the element can be reassembled and reused. **It is recommended that a new rotating element be used for reassembly.** DO NOT attempt to remove the seal using a screwdriver or other sharp object. Extensive damage to the shaft or element could occur.

19. On inducer pumps (L50 Series), the Seal Driver (#88) can be removed from the shaft if it needs to be replaced.

20. Before the Inlet Cover (#1 or #1IN) can be removed, the four (4)

Guide Rod "O"rings (#8) must be removed.

- a. Gently tap on the back of the inlet cover, alternating between the left and right side, until the Inlet Cover moves approximately 1/4".
- b. Tap the inlet cover face to move it back to its original position, exposing the Guide Rod "O"rings.
- c. Remove the "O"rings by sliding them off the Guide Rods.
- d. Slide the Inlet Cover straight off. Do not attempt to remove the Inlet Cover without first removing the "O"rings (#8).

21. Remove the stationary seat (#125). Refer to Figure 4-10.

- a. Place the inlet cover face down on a flat surface.
- b. Looking into the opening in the center of the inlet cover, you will see a portion of the seat.
- c. Insert a 1" dowel, and very gently, tap the seat until it drops out.
- d. Care must be taken with the seats. They are a brittle material and are prone to breakage. It is recommended that a replacement seat be used during reassembly.

22. For further disassembly of models on a bearing frame, see Service 4C Bearing Pedestals, Disassembly (P30). Proceed to step 23 for close-coupled models.

23. Remove the four (4) long hex screws that hold the End Bell (#101) to the motor.

24. Pull the endbell assembly off the motor. If the taper of the adapter shaft in the motor shaft did not separate, remove the motor fan and carefully pull out the motor rotor. A sharp, careful blow with a hammer on the motor shaft at the taper should free the grip of the taper.

25. Remove the guide rod nuts and guide rods from the endbell.

26. With a spanner wrench, unscrew the Outboard Bearing Adjusting Nut (#110A) from the endbell.

27. Support endbell with pump mounting face up and press out adapter shaft/bearing assembly with an arbor press. Remove Inboard Bearing Adjusting Nut (#110)

28. Disengage bearing lockwasher tang from slot in the Bearing Locknut (#38), using a thin blade screwdriver. Remove Bearing Locknut and Lockwasher.

29. Place the shaft/bearing assembly in arbor press and remove the Bearing (#24).

Proceed to section 4E Inspection of Components.

C3 - P3 CLOSE COUPLED PUMP			QTY. PER PUMP				
KEY NO.	NAME / DESCRIPTION	USED ON	1 STG	2 STG	3 STG	4 STG	5 STG
1	Inlet Cover - Standard	M50	N/A	1	1	1	1
1 IN	Inlet Cover - Inducer	L50	1	1	1	1	1
2	Outlet Cover	All	1	1	1	1	1
7	"O" Ring - Casing	All	4	5*	7*	9*	11*
7A	"O" Ring - Drain Plug	All	1	1	1	1	1
7B	"O" Ring - Inlet	All	1	1	1	1	1
8	"O" Ring - Guide Rod	All	8	8	8	8	8
86 IN	Diffuser Ring	L50	1	1	1	1	1
9	Channel Ring - Right Hand	All	1	2	3	4	5
10	Channel Ring - Left Hand	All	1	2	3	4	5
11	Impeller	All	1	2	3	4	5
11 IN	Impeller - Inducer	L50	1	1	1	1	1
12	Seal - Rotating Element	All	1	1	1	1	1
125	Seal Seat	All	1	1	1	1	1
14	Drive Collar	All	1	1	1	1	1
14A	Snap Ring	L50	2	2	2	2	2
15	Set Screws - Drive Collar	All	2	2	2	2	2
16	Interstage Bushing	All	1	2	3	4	5
16A	Bearing	SS	1**	2**	3**	4**	5**
17	Shaft	All	1	1	1	1	1
18	Guide Rod	All	4	4	4	4	4
19	Thru Bolt	All	8	8	8	8	8
20	Nuts	All	16	16	16	16	16
20A	Nuts	Horiz.	2	2	2	2	2
22	Pipe Plug - Drain (Not Shown)	All	1	1	1	1	1
23A	Drive Key	All	2	2	3	4	5
31	Mounting Bracket	Horiz.	1	1	1	1	1
33	Bolt	Horiz.	2	2	2	2	2
41	Washer	Horiz.	4	4	4	4	4
87	Plain Bearing	All	1	1	1	1	1
88	Seal Driver	L50	1	1	1	1	1

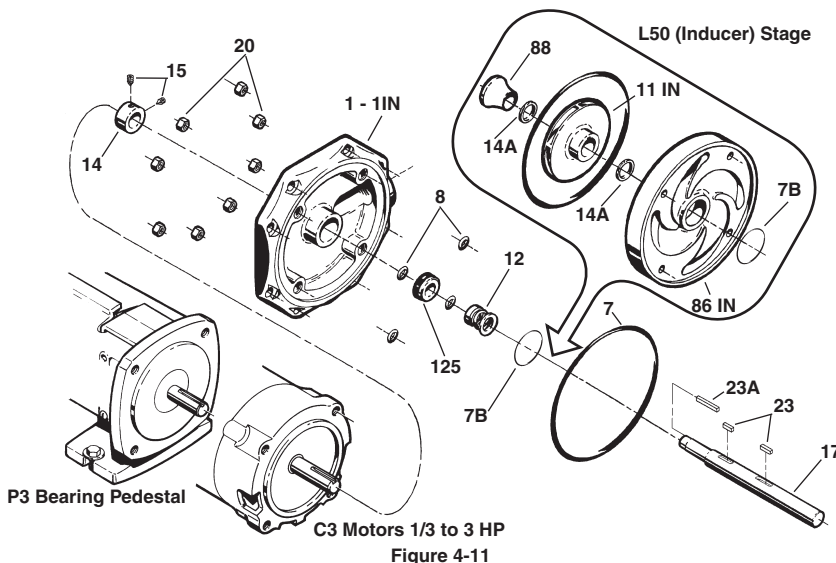

Figure 4-11

4E Inspection of Components

Thoroughly clean all parts. All components should be examined for wear and corrosion. Replace any parts that show visible wear. If the pump was not producing sufficient pressure or capacity, the clearances between the casing and impeller probably exceed the maximum allowable clearance. At minimum, the impellers should be replaced in this case. If the total side running clearance for an impeller exceeds .007", it is unlikely that pump performance will reach that of a new pump except at lower discharge pressures.

The "O" rings and other elastomeric components should be replaced if they have been deformed or cut.

If seal components must be reused, carefully inspect for microscopic cracks and nicks. Scratches that might be ignored elsewhere can produce leakage if they are on seal carbons and seat wearing surfaces.

Cleanliness is imperative when working with mechanical seals. Almost unnoticeable particles between seal faces can be, and often are, the cause of early seal failures.

Check the impellers, they are designed to float. They should move easily on the shaft. As long as they can be moved on the shaft by hand, they are loose enough. If the impeller can be rocked or wobbled, it is too loose and must be replaced.

Check the sleeve or shaft for galling, pitting, and corrosion. If the shaft or sleeve is corroded where the seal comes in contact with them, the shaft or sleeve must be replaced. Surface corrosion must be removed so that seals can slide freely during assembly. The shaft diameter should

be no smaller than .002" below the nominal fractional seal sizes. Remove any nicks or burrs which may have occurred during disassembly. Reclean parts as necessary.

4F Reassembly Vertical Single Stage on C3 Motors

All parts should be visually inspected and cleaned or replaced as outlined in 4F above.

The following tools are needed for reassembly of C3 units.

1. 9/16" wrench or socket.
2. 5/32" hex wrench.
3. Soft plastic or wooden mallet.
4. Cealube G or similar glycol base lubricant. (DO NOT use petroleum products.)

To reassemble the pump:

Refer to Figure 4-4 for reference to the numbered parts in the procedures below.

1. The Seal Stationary Seat (#125) must be installed in the Motor Bracket (#1) before the bracket is installed on the motor. To install the seat:
 - a. Place the motor bracket face up on a flat surface.
 - b. Carefully press the seat, smooth side up, into the seat cavity of the motor bracket. To make the installation of the seat easier, apply a thin coating of compatible lubricant to the elastomer portion of the seat prior to installation. Care must be taken not to damage the seat face. Thumb pressure is usually sufficient to install the seat.

2. Install the motor bracket.
 - a. Make sure the Locking Collar (#14) is positioned on the motor shaft.
 - b. Thread two (2) Guide Rods (#18) into the top holes of the motor face. (Use four (4) guide rods on stainless steel models).
 - c. While holding the motor bracket with the outlet port facing up, slide the bracket over the guide rods until the feet are resting against the motor face. Light tapping may be necessary to seat the motor bracket in the proper position.
 - d. Install two (2) "O" Rings on each of the (top) two guide rods. This will help hold the bracket in place during the remainder of the assembly operation.
3. Install the shaft sleeve and rotating element as a unit.
 - a. Place the Shaft Sleeve (#17) in an upright position with the smaller end facing up.
 - b. Lubricate the shaft sleeve and Seal Rotating Element (#12).
 - c. Be sure to install a Drive Key (#23A) in the motor shaft before installing the sleeve and seal assembly.
 - d. Holding the element assembly between the thumb and index finger of both hands, slide the assembly over the sleeve until the spring holder rests against the shoulder of the sleeve. Refer to Figure 4-13.
 - e. The element must slide freely up and down on the sleeve. It is necessary to maintain some downward pressure on the element because the spring tension could dislodge the seal portion of the element.

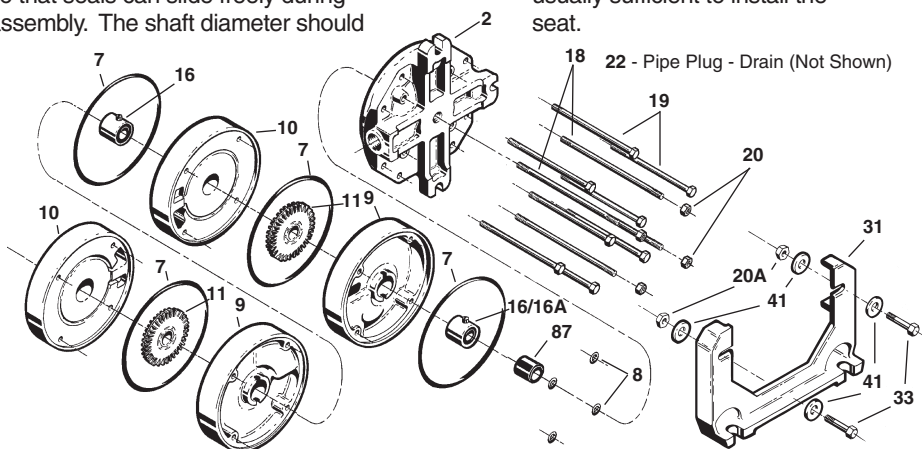

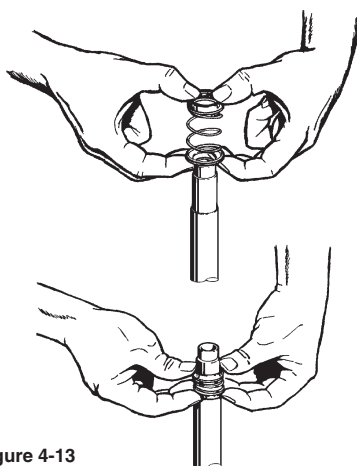

Figure 4-13

- f. Holding the assembled sleeve between the thumb and index finger, slide the assembly onto the motor shaft.
- g. Push the sleeve on until it comes in contact with the locking collar.
- h. Position the collar over the sleeve end and push the sleeve on until it stops.
- i. While maintaining inward pressure on the sleeve with one hand, line up the collar setscrews with the key in the shaft sleeve, one setscrew on each side of the key.
- j. Tighten the setscrews snugly.
- k. Pressure can now be released and the sleeve should remain in position.
The spring holder must be below the impeller wearing surface of the motor bracket for proper impeller operation.

4. Install the Impeller (#11).

- a. Place an Impeller Key (#23) in the shaft sleeve.
- b. The impeller is a slip fit and should slide on firmly but easily until it stops against the impeller wearing surface. Force should not be required to install the impeller in the correct position.
- c. The impeller hub should be facing out away from the motor bracket. Refer to Figure 4-4.

C30 - P30 CLOSE COUPLED PUMP

KEY NO.	NAME / DESCRIPTION	USED ON	QTY. PER PUMP				
			1 STG	2 STG	3 STG	4 STG	5 STG
1	Inlet Cover - Standard	M50	N/A	1	1	1	1
1 IN	Inlet Cover - Inducer	L50	1	1	1	1	1
2	Outlet Cover	All	1	1	1	1	1
7	"O" Ring - Casing	All	4	5	7	9	11
7A	"O" Ring - Drain Plug	All	1	1	1	1	1
7B	"O" Ring - Inlet	All	1	1	1	1	1
8	"O" Ring - Guide Box	All	8	8	8	8	8
86 IN	Diffuser Ring	L50	1	1	1	1	1
9	Channel Ring - Right Hand	All	1	2	3	4	5
10	Channel Ring - Left Hand	All	1	2	3	4	5
11	Impeller	All	1	2	3	4	5
11 IN	Impeller - Inducer	L50	1	1	1	1	1
12	Seal - Rotating Element	All	1	1	1	1	1
125	Seal Seat	All	1	1	1	1	1
14A	Snap Ring	L50	2	2	2	2	2
16	Interstage Bushing	All	1	2	3	4	5
16A	Bearing	SS	1**	2**	3**	4**	5**
17	Pump Shaft	All	1	1	1	1	1
17A	Motor Shaft	P30	1	1	1	1	1
18	Guide Rod	All	4	4	4	4	4
19	Thru Bolt	All	8	8	8	8	8
20	Nuts	All	16	16	16	16	16
20A	Nuts	Horiz.	2	2	2	2	2
22	Pipe Plug - Drain (Not Shown)	All	1	1	1	1	1
23	Impeller Key	All	2	2	3	4	5
23A	Motor Shaft Key	P30	1	1	1	1	1
24	Ball Bearing/Inboard	P30	1	1	1	1	1
31	Mounting Bracket	Horiz.	1	1	1	1	1
33	Bolt	Horiz.	2	2	2	2	2
33D	Bearing Frame Thru-bolt	P30	1	1	1	1	1
38	Bearing Locknut	P30	1	1	1	1	1
39	Bearing Lockwasher	P30	1	1	1	1	1
41	Washer	Horiz.	4	4	4	4	4
87	Plain Bearing	All	1	1	1	1	1
88	Seal Driver	L50	1	1	1	1	1
101	End Bell	P30	1	1	1	1	1
110	Bearing Adjusting Nut - Inboard	P30	1	1	1	1	1
110A	Bearing Adjusting Nut - Outboard	P30	1	1	1	1	1
120	Motor Draw Bolt	All	1	1	1	1	1

** Subtract one for L50 & M50 Series Stainless Steel Pumps

- d. If the impeller does not fit, repeat steps a. and b. to determine the problem. shaft will not turn, loosen the bolts equally until the impeller moves freely.
5. Place "O"Ring (#7) into the "O"Ring groove in the motor bracket. It is helpful to stand the motor and pump assembly on end for this procedure. Proceed to section 4I Testing and Final Adjustment.
6. Place the cover over the motor bracket and install the two (2) 3/8"X4" bolts (#19), and two (2) nuts (#20). Stainless steel models require four (4) nuts (#20). Tighten the bolts and/or nuts systematically, alternating diagonally across the cover. **4G Reassembly Multistage on C3 Motors / P3 Bearing Frames**
All parts should be visually inspected and cleaned or replaced as outlined in 4E above.
The following tools and equipment are needed for reassembly of C3 / P3 units:
7. After the bolts and/or nuts are "snugged up", make sure the impeller is not binding by inserting a 5/32" hex wrench into the locking collar and moving it left to right. The shaft should rotate with little or no resistance. If the
1. Soft plastic or wooden mallet.
 2. Two 9/16" wrenches or sockets.
 3. 5/32" hex wrench.
 4. Cealube G or similar glycol base lubricant. (DO NOT use petroleum products.)
- To reassemble the pump:

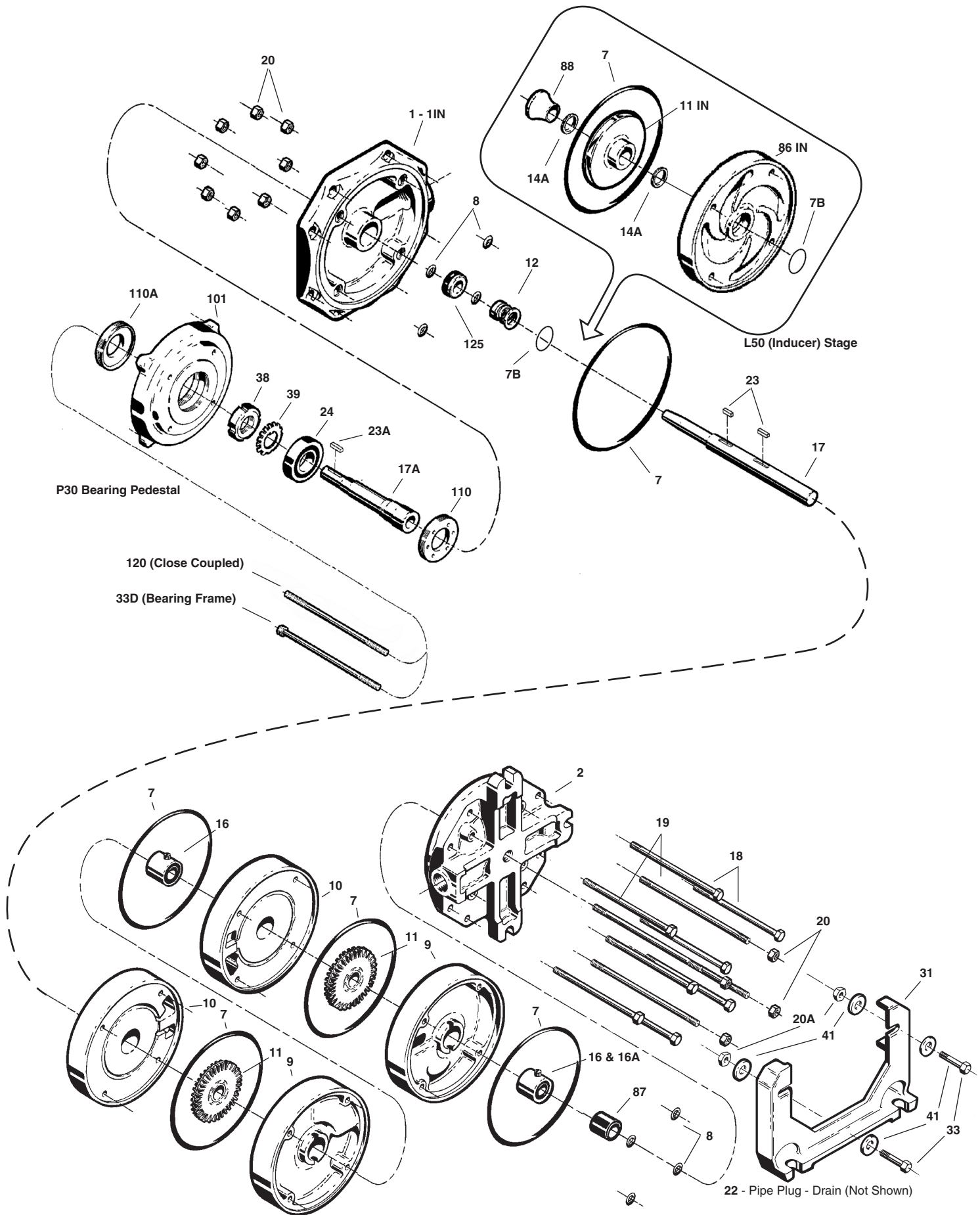

Figure 4-12

Refer to Figure 4-11 for reference to the numbered parts in the reassembly below.

1. Install the guide rods. Thread the four (4) Guide Rods (#18) into the motor or bearing frame face. It is not necessary to turn them in completely or tighten. About half of the thread length should be fine.
 2. The Seat Stationary Seat (#125) must be installed in the Inlet Cover (#1 or #1IN) before the cover is installed on the motor. To install the seal seat:
 - a. Place the inlet cover face up on a flat surface.
 - b. Carefully press the seat, smooth side up, into the seat cavity of the inlet cover. To make the installation of the seat easier, apply a thin coating of glycol base lubricant to the elastomer portion of the seat prior to installation. Care must be taken not to damage the seat face. Thumb pressure is usually sufficient to install the seat.
 3. Install the Inlet Cover (#1 or 1IN).
 - a. Make sure the Drive Collar (#14) is positioned on the motor shaft.
 - b. While holding the inlet cover with the inlet port 180° from the motor conduit box (or vertically on horizontal units), slide the cover over the guide rods on the face.
 - c. Slide the inlet cover back until the feet are resting against the face. Light tapping may be necessary to seat the inlet cover in the proper position.
 - d. Install one (1) "O" Ring (#8) on each of the four guide rods. This will help hold the bracket in place during the remainder of the assembly operation.
 4. On inducer pumps (L50 Series) install one Snap Ring (#14A) in the groove nearest the drive end of the Shaft (#17), and slide the Seal Driver (#88) on the shaft.
 5. Install the Shaft (#17) and Seal Rotating Element (#12) as a unit.
 - a. Lubricate the small end of the shaft and the rotating element.
 - b. Holding the element assembly between the thumb and index finger of both hands, slide the assembly over the shaft until the spring holder rests against the shoulder. Refer to Figure 4-13.
 - c. The element must slide freely up and down the shaft. It is necessary to maintain some downward pressure on the element because the spring tension could dislodge the seal portion of the element.
 - d. Install a Drive Key (#23A) in the motor shaft before installing the shaft and seal assembly.
 - e. Align the keyway and slide the pump shaft over the motor shaft. Push the shaft in until it comes in contact with the drive collar.
 - f. Position the drive collar over the shaft end and push the shaft on until it stops.
 - g. While maintaining inward pressure on the shaft with one hand, line up the Collar Setscrews (#15) with the key in the motor shaft, placing one setscrew on each side of the keyway.
 - h. Using the hex wrench, tighten the set screws snugly.
 - i. Pressure can now be released, and the sleeve should remain in position. **Make certain the spring holder is below the top surface of the seal cavity for proper impeller operation.**
 6. It is recommended that the assembly be placed vertically on the motor or pedestal end for further assembly. Blocks can be used to steady the unit.
- For standard (M50 Series) pumps, skip to step 9.
7. For inducer (L50 series), install the Inducer Impeller (#11IN). Refer to the L50 Inducer Stage Inset in Figure 4-11.
 - a. Install an Impeller Key (#23) in the shaft by the drive collar.
 - b. Slide the inducer impeller on the shaft with the eye facing the drive end.
 - c. Install the other Snap Ring (#14A) on the shaft at the hub of the inducer impeller.
 8. Install the Diffuser Ring (#86IN).
 - a. Place an "O"Ring (#7) on the raised step in the diffuser ring. You will need to stretch the "O"ring slightly to do so.
 - b. Coat the "O"ring and the lip inside the inlet cover with a small amount of glycol base lubricant.
 - c. With the "O"ring facing the inlet cover, slide the diffuser ring onto the guide rods so that it fits over the inducer impeller. Push on firmly until the "O" ring fits inside the lip in the inlet cover. Refer to Figure 4-14.

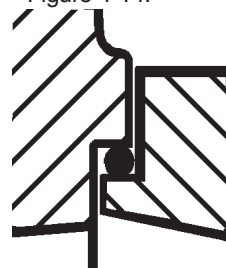

Figure 4-14

9. Installation of the First Stage

- a. Place the small "O"Ring (#7B) in to the groove in the hub of the inlet cover (#1 - 1IN) or Diffuser Ring (#86IN)
- b. Install an Impeller Key (#23) in the shaft.
- c. Place an "O" ring (#7) on the raised step in the channel

- ring. You will need to stretch the "O" ring slightly to do so.
- d. Coat the "O" ring and lip in inlet cover (or diffuser ring) with a small amount of glycol base lubricant.
 - e. With the "O" ring facing the motor end, slide the channel ring (#10) onto the guide rods with the water channel facing up. The large inlet opening should be on the same side as the pump inlet. Refer to figure 4-15. Push on firmly until the "O" ring fits inside the lip in the inlet cover (or diffuser ring). Refer to Figure 4-14.

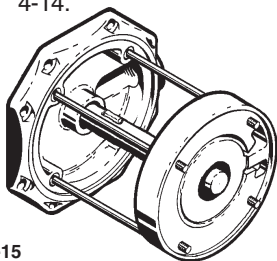

Figure 4-15

10. Slide an Impeller (#11) on the shaft and over the drive key, with the impeller hub facing the motor. Refer to Figure 4-11.
11. Install a Right Hand Channel Ring (#9).
 - a. Place an "O" Ring (#7) on the raised step in the channel ring. You will need to stretch the "O" ring slightly to do so.
 - b. Coat the "O" ring and lip in previous ring with a small amount of glycol base lubricant.
 - c. With the "O" ring facing the left hand channel ring, slide the channel ring onto the guide rods. The small outlet opening should be on the same side as the pump inlet. Refer to Figure 4-16. Push

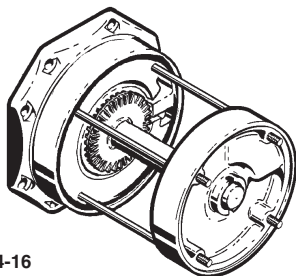

Figure 4-16

- on firmly until the "O" ring fits inside the lip in the left hand channel ring. Refer to Figure 4-14.
12. Slide an Interstage Bushing (#16) onto the shaft. The bushing should be oriented such that the end with the screw is furthest from the motor and the screw head fits into the slot in the right channel ring. Refer to Figure 4-17.

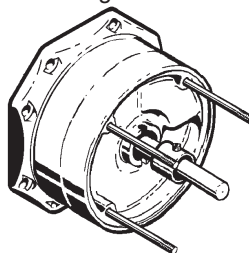

Figure 4-17

This completes one stage; a stage consists of one Left Hand Channel Ring (#10), a Right Hand Channel Ring (#9), and an Impeller (#11) between them. Refer to Figure 4-11.

13. Install another Left Hand Channel Ring (#10).
 - a. Install an Impeller Key (#23) in the shaft.
 - b. Place an "O" Ring (#7) on the raised step in the channel ring. Lubricate the "O" ring and inside lip in previous channel ring.
 - c. Slide the channel ring into place with the water channel facing up. This time, however, orient the large inlet opening on the side opposite of the pump inlet. Refer to Figure 4-18.

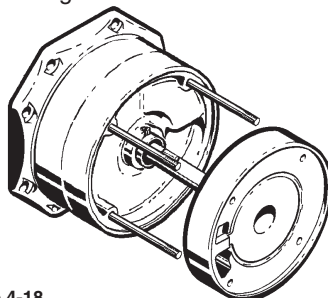

Figure 4-18

14. Install another Impeller (#11), remembering to point the impeller hub towards the motor.
15. Install another Right Hand Channel Ring (#9).

- a. Place an "O" Ring (#7) on the raised step in the channel ring and lubricate.
- b. Slide the channel ring onto the guide rods with the water channel facing down towards the impeller. The small outlet opening should be on the opposite side from the pump inlet. Refer to Figure 4-19. Push on firmly until the "O" ring fits inside the lip in the previously installed channel ring.

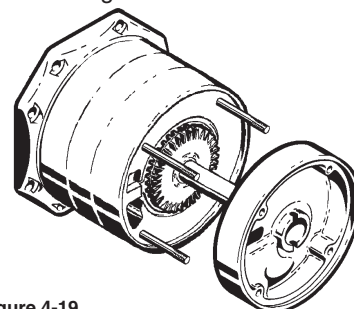

Figure 4-19

16. Slide an Interstage Bushing (#16) onto the shaft. The bushing should be oriented such that the end with the screw is furthest from the motor and the screw head fits into the slot in the right channel ring. Refer to Figure 4-17.

Continue installing stages depending on how many stages are in the pump by repeating steps 9 through 16. Remember to stagger the ring sets to balance radial loads. The odd numbered stages should have openings on the same side as the pump inlet, as described in the first stage installation (steps 9 through 12). The even numbered stages should have their openings on the opposite side from the pump inlet, as indicated (in steps 13 through 16) for the second stage).

17. Install one (1) "O" Ring (#8) on each of the four Guide Rods (#18)
18. Replace the Plain Bearing (#87) in the Outlet Cover (#2), if it has been removed. If not, proceed to step 19. The bearing is an interference fit and the Outlet Cover must be heated to approximately 300°F before pressing in. Allow the Outlet Cover to cool before proceeding with the next step.

19. Install the Outlet Cover

- a. Place an "O"Ring (#7) on the raised step in the outlet cover. You will need to stretch the "O"Ring slightly to do so.
- b. Coat the "O"Ring and lip in the last right channel ring (#9) with a small amount of glycol based lubricant.
- c. With the "O"Ring facing the last channel ring, slide the Outlet Cover (#2) over the Guide Rods. The outlet port should be oriented 180° from the inlet port on close coupled units. The outlet port should be oriented on the same side as the inlet port on horizontal units. Push on firmly until the "O"Ring fits inside the lip of the channel ring. Refer to figure 4-20.

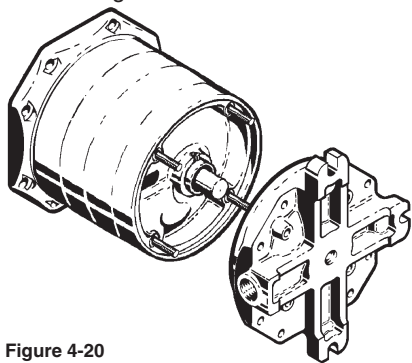

Figure 4-20

20. Insert the eight (8) Thru Bolts (#19) through the holes in the outlet cover and the inlet cover. Thread one (1) Nut (#20) on each of the eight Thru Bolts and on the end of each Guide Rod (#18). Using two 9/16" wrenches or sockets, tighten the bolts/nuts systematically, alternating diagonally across the cover, until they are about one full turn short of being fully torqued.
21. After the bolts/nuts are "snugged up", make sure the impellers are not binding by inserting the 3/8" hex wrench through the drain hole in the Outlet Cover and in the socket in the end of the shaft and turn. The shaft should rotate with little or no resistance. If the shaft will not turn, loosen the bolts equally until the impellers move freely.

Proceed to Section 4I Testing and Final Adjustments

4H Reassembly Multistage on C30 Motors / P30 Bearing Frames

All parts should be visually inspected and cleaned or replaced as outlined in 4E above.

The following tools and equipment are needed for reassembly of C30 / P30 units:

1. Soft plastic or wooden mallet.
2. Two 9/16" wrenches or sockets.
3. 3/4" wrench or socket
4. Adjustable wrench.
5. Adjustable spanner wrench.
6. Thin blade screwdriver.
7. 3/8" hex wrenches.
8. Cealube G or similar glycol base lubricant. (DO NOT use petroleum products.)
9. 7/16" wrench or socket

To reassemble the pump:

Refer to Figures 4-12 for reference to the numbered parts in the reassembly below.

1. Using an arbor press, install the Bearing (#24) on the Motor Adapter Shaft or Bearing Frame Shaft (#17).
2. Install Bearing Lockwasher (#39) on the shaft, aligning internal tang into the keyway in the shaft, and with the external tangs facing away from the bearing. Install Bearing Locknut (#38) on shaft, with beveled side facing the bearing. Tighten snugly, using a drift punch if necessary, until a slot lines up with a tang on the lockwasher. Using a thin blade screwdriver, bend the tang into the slot in the locknut.
3. Thread the Outboard Bearing Adjusting Nut (#110A) into bore inside the Endbell (#101). The adjusting nut should be approximately flush with the top of the bore.
4. Place endbell, pump mounting surface up, on the arbor press face plate. Press shaft assembly into bearing bore until the bearing rests against the adjusting nut. Thread the Inboard Bearing

Adjusting Nut (#110) into the bore (this adjusting nut has a left hand thread). It is not necessary to tighten the adjusting nuts completely until the pump has been assembled to the endbell, as some adjustment will be necessary.

5. Place endbell assembly vertically on a workbench, elevating endbell with blocks so the adapter shaft or bearing frame shaft clears the bench top.
6. Insert four (4) Guide Rods (#18) through the holes in the Endbell, and thread one (1) nut (#20) onto each of the guide rods. You may need to use more blocks to hold the guide rods up against the back of the endbell.
7. The Seat Stationary Seat (#125) must be installed in the Inlet Cover (#1 or #1IN) before the cover is installed on the motor. To install the seal seat:
 - a. Place the inlet cover face up on a flat surface.
 - b. Carefully press the seat, smooth side up, into the seat cavity of the inlet cover. To make the installation of the seat easier, apply a thin coating of glycol base lubricant to the elastomer portion of the seat prior to installation. Care must be taken not to damage the seat face. Thumb pressure is usually sufficient to install the seat.
8. Install the Inlet Cover (#1 or 1IN).
 - a. Make sure the Drive Collar (#14) is positioned on the motor shaft.
 - b. While holding the inlet cover with the inlet port 180° from the motor conduit box (or vertically on horizontal units), slide the cover over the guide rods on the face.
 - c. Slide the inlet cover back until the feet are resting against the face. Light tapping may be necessary to seat the inlet cover in the proper position.

- d. Install one (1) "O" Ring (#8) on each of the four guide rods. This will help hold the bracket in place during the remainder of the assembly operation.
9. On inducer pumps (L50 Series) install one Snap Ring (#14A) in the groove nearest the drive end of the Shaft (#17), and slide the Seal Driver (#88) on the shaft.
10. Install the Shaft (#17) and Seal Rotating Element (#12) as a unit.
- Lubricate the small end of the shaft and the rotating element.
 - Holding the element assembly between the thumb and index finger of both hands, slide the assembly over the shaft until the spring holder rests against the shoulder. Refer to Figure 4-13.
 - The element must slide freely up and down the shaft. It is necessary to maintain some downward pressure on the element because the spring tension could dislodge the seal portion of the element.
 - Slide the shaft into the taper of the Adapter shaft or Bearing frame shaft. Push shaft in until it stops.
 - While maintaining inward pressure on the shaft with one hand, insert the Bearing Frame Thru Bolt (on units on a bearing frame) or a 3/8-16 bolt of the appropriate length (See Chart 1 - for close coupled models) into the hole of the bearing frame shaft/ adapter shaft. Thread the bolt into the pump shaft. You may now release pressure from the shaft.
- f. Insert 3/8" hex wrench into the socket in the pump shaft and hold while tightening the bolt, drawing the two shafts together.
11. Look at the pump shaft between the Endbell (#101) & Inlet Cover (#1 or #11N). There should be a scribed line around the shaft visible. This line is used to set the proper seal working height. It should line up with the machined surface of the Inlet Cover where the shaft goes through. If the line is not visible or does not line up properly, the shaft can be moved by tightening or loosening the Bearing Adjusting Nuts (#110 & #110A) using the adjustable spanner wrench. Once the proper location is established, both Bearing Adjusting Nuts must be tightened against the bearing.
- For standard (M50 Series) pumps, skip to step 14.
12. For inducer (L50 series), install the Inducer Impeller (#11IN). Refer to the L50 Inducer Stage Inset in Figure 4-12.
- Install an Impeller Key (#23) in the shaft by the drive collar.
 - Slide the inducer impeller on the shaft with the eye facing the drive end.
 - Install the other Snap Ring (#14A) on the shaft at the hub of the inducer impeller.
13. Install the Diffuser Ring (#9IN).
- Place an "O"Ring (#7) on the raised step in the diffuser ring. You will need to stretch the "O"ring slightly to do so.
 - Coat the "O"ring and the lip inside the inlet cover with a small amount of glycol base lubricant.
 - With the "O"ring facing the inlet cover, slide the diffuser ring onto the guide rods so that it fits over the inducer impeller. Push on firmly until the "O" ring fits inside the lip in the inlet cover. Refer to Figure 4-14.
14. Installation of the First Stage
- Place the small "O"Ring (#7B) in to the groove in the hub of the Inlet Cover (#1 - 11N) or Diffuser Ring (#9IN).
 - Install an Impeller Key (#23) in the shaft.
 - Place an "O" ring (#7) on the raised step in the channel ring. You will need to stretch the "O" ring slightly to do so.
 - Coat the "O" ring and lip in inlet cover (or diffuser ring) with a small amount of glycol base lubricant.
 - With the "O"ring facing the motor end, slide the channel ring onto the guide rods with the water channel facing up. The large inlet opening should be on the same side as the pump inlet. Refer to figure 4-15. Push on firmly until the "O"ring fits inside the lip in the inlet cover (or diffuser ring). Refer to Figure 4-14.
15. Slide an Impeller (#11) on the shaft and over the drive key, with the impeller hub facing the motor. Refer to Figure 4-12.
16. Install a Right Hand Channel Ring (#9).
- Place an "O"Ring (#7) on the raised step in the channel ring. You will need to stretch the "O"ring slightly to do so.
 - Coat the "O"ring and lip in previous ring with a small amount of glycol base lubricant.
 - With the "O"ring facing the left hand channel ring, slide the channel ring onto the guide rods. The small outlet opening should be on the same side as the pump inlet. Refer to Figure 4-16. Push on firmly until the "O" ring fits inside the lip in the left hand channel ring. Refer to Figure 4-14.

CHART 1

Motor Frame	Bolt Length
180	4"
210	4 1/2"
250	5"
280	5"

17. Slide an Interstage Bushing (#16) onto the shaft. The bushing should be oriented such that the end with the screw is further from the motor and the screw head fits into the slot in the right channel ring. Refer to Figure 4-17.

This completes one stage; a stage consists of one Left Hand Channel Ring (#10), a Right Hand Channel Ring (#9), and an Impeller (#11) between them. Refer to Figure 4-12.

18. Install another Left Hand Channel Ring (#10).
- Install an Impeller Key (#23) in the shaft.
 - Place an "O"Ring (#7) on the raised step in the channel ring. Lubricate the "O"ring and inside lip in previous channel ring.
 - Slide the channel ring into place with the water channel facing up. This time, however, orient the large inlet opening on the side opposite of the pump inlet. Refer to Figure 4-18.
19. Install another Impeller (#11), remembering to point the impeller hub towards the motor.
20. Install another Right Hand Channel Ring (#9).
- Place an "O"Ring (#7) on the raised step in the channel ring and lubricate.
 - Slide the channel ring onto the guide rods with the water channel facing down towards the impeller. The small outlet opening should be on the opposite side from the pump inlet. Refer to Figure 4-19. Push on firmly until the "O"ring fits inside the lip in the previously installed channel ring.
21. Slide an Interstage Bushing (#16) onto the shaft. The bushing should be oriented such that the end with the screw is further from the motor and the screw head fits into the slot in the right channel ring. Refer to Figure 4-17.

Continue installing stages depending on how many stages are in the pump by repeating steps 14 through 21. Remember to stagger the ring sets to balance radial loads. The odd numbered stages should have openings on the same side as the pump inlet, as described in the first stage installation (steps 14 through 17). The even numbered stages should have their openings on the opposite side from the pump inlet, as indicated (in steps 15 through 21).

22. Install one (1) "O"Ring (#8) on each of the four Guide Rods (#18)
23. Replace the Plain Bearing (#87) in the Outlet Cover (#2), if it has been removed. If not, proceed to step 24. The bearing is an interference fit and the Outlet Cover must be heated to approximately 300°F before pressing in. Allow the Outlet Cover to cool before proceeding with the next step.
24. Install the Outlet Cover
- Place an "O"Ring (#7) on the raised step in the outlet cover. You will need to stretch the "O"Ring slightly to do so.
 - Coat the "O"Ring and lip in the last right channel ring (#9) with a small amount of glycol based lubricant.
 - With the "O"Ring facing the last channel ring, slide the Outlet Cover (#2) over the Guide Rods. The outlet port should be oriented 180° from the inlet port on close coupled units. The outlet port should be oriented on the same side as the inlet port on horizontal units. Push on firmly until the "O"Ring fits inside the lip of the channel ring. Refer to Figure 4-20.
25. Insert the eight (8) Thru Bolts (#19) through the holes in the outlet cover and the inlet cover. Thread one (1) Nut (#20) on each of the eight Thru Bolts and on the end of each Guide Rod (#18). Using two 9/16" wrenches or sockets, tighten the bolts/nuts systematically, alternating

diagonally across the cover, until they are about one full turn short of being fully torqued.

26. After the bolts/nuts are "snugged up", make sure the impellers are not binding by inserting the 3/8" hex wrench through the drain hole in the Outlet Cover and in the socket in the end of the shaft and turn. The shaft should rotate with little or no resistance. If the shaft will not turn, loosen the bolts equally until the impellers move freely.

For C30 (close coupled) models proceed to step 27. For models on a P30 Bearing Frame, continue assembling bearing frame as outlined in Section 4F Reassembly P30 Bearing Frames.

27. Remove the bolt installed in the adapter shaft in step 10 used to draw the shaft tapers together.
28. Install the motor over the endbell/pump assembly and tighten the four (4) long hex screws that connect the motor to the endbell. You may find it easier to lay the unit on its side for this operation.
29. Insert the motor Draw Bolt (#120) into the hole in the motor shaft (on the fan end) and thread it into the pump shaft. Install the nut on end of the stud and tighten. You will need to hold the pump shaft with the 3/8" hex wrench while tightening.
30. Install the Drain Plug (#22) in the Outlet Cover and install the fan shroud on the motor.

Proceed to Section 4I Testing and Final Adjustment.

4I Testing and Final Adjustments

The pump is now ready for installation. Final adjustments will be made with the pump in operation.

- Reconnect the electrical connections referring to the colored or numbered tape used to mark the wires.
- Connect all piping and fill the pump with fluid. Ensure the pump is properly primed and

vented, prior to operation. DO NOT RUN THE PUMP WITHOUT FLUID.

3. Make sure all valves are open, and fluid will flow through the system.
4. Start the pump and make the final adjustments to the 3/8" bolts and/or nuts holding the cover on. These bolts and nuts must

be torqued to about 20 ft. lbs. to obtain proper performance.

5. Check for leaks on pump and piping. Special attention should be given to the seal area at the rear opening in the motor bracket.

6. Under pressure, the impeller will find its "hydraulic" balance.

7. Using an amprobe or similar device, check for motor overload.

8. While the impeller is finding its balanced position, it is common to experience some variance in readings. After a run-in period the readings should level off.

This completes the adjustment and testing phase. The pump is ready for service.

M50 • L50 SERIES

4. Service

BEARING PEDESTALS

- A. Preliminary
- B. Disassembly (P3)
- C. Disassembly (P30)
- D. Inspection of Components
- E. Reassembly (P3)
- F. Reassembly (P30)
- G. Testing and Final Adjustments

4A Preliminary P3 and P30

1. Disconnect the inlet and outlet piping before unbolting the pump. If the pipes are corroded, use penetrating oil on the threads to aid in removal.
2. Unbolt the pump from the base and remove. Disassembly instructions for the pump are found in Section 4, M50 • L50 PUMP ENDS. All work on the unit should be performed on an elevated work-bench whenever possible.

The disassembly and reassembly procedures are broken into four sections covering the following units:

- 4B — Disassembly of the P3 Bearing Pedestals
- 4C — Disassembly of the P30 Bearing Pedestals
- 4E — Reassembly of the P3 Bearing Pedestals
- 4F — Reassembly of the P30 Bearing Pedestals

Exploded views of each unit, Figures 4-27 and 4-28 are provided for referencing the numbers in the following procedures, i.e. Flinger (#21).

4B Disassembly (P3)

The following tools and equipment are needed for disassembly of the P3 units:

1. Plastic or wooden mallet
2. Arbor press or vise
3. 3/4" X 6" piece of water pipe
4. Internal snap ring plier
5. Penetrating oil

When installing or removing bearings from the shaft, the use of an arbor press is strongly recommended.

To disassemble the pedestal:

Refer to Figure 4-24 for reference to the numbered parts in the procedures below.

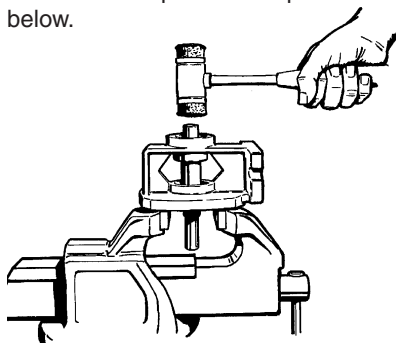

Figure 4-21

1. Remove the Flinger (#21) located on the pump end of the Bearing Pedestal (#3).
2. Using a snap ring plier, remove Snap Ring (#4).
3. Open the jaws of the vice approximately 2-1/4".
4. Place the pedestal, pump side down, on the jaws. Refer to Figure 4-21

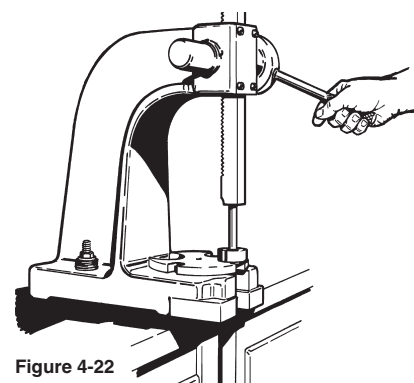

Figure 4-22

5. Using a plastic or wooden mallet, gently tap on the end of the shaft until it slides out of the frame. Both bearings should come out with the shaft. Do not use a metal hammer; severe damage to the shaft will occur.
6. Using the arbor press, remove the two (2) Bearings (#24 & #24A) from the shaft. Refer to Figure 4-22. If the inner race is well supported during this operation, no damage will be done to the bearings.

If an arbor press is not available, a bench vise may be substituted using the following procedure:

1. Remove the pedestal and close the jaws to approximately 1-1/8".

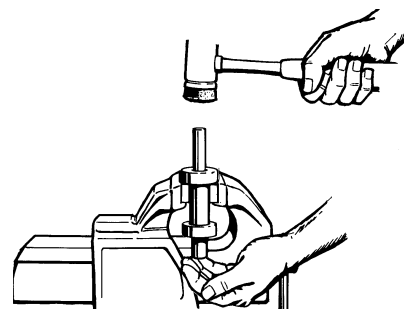

Figure 4-23

- Place the shaft with either bearing resting on top of the jaws and gently tap on the end of the shaft until the bearing is removed. Refer to Figure 4-23.

	P3	P30
I.D.	1"	1 5/16" - 1 1/2"
O.D.	2"	2 3/4" - 3"

- Repeat step 2 to remove the other bearing. Good support used on the inner races will prevent bearing damage.

4C Disassembly (P30)

Disassemble pump components as shown in **Section 4, M50 • L50 PUMP ENDS, 4E Disassembly Multistage on C30 Motors / P30 Bearing Frames.**

The following tools and equipment are needed for disassembly of the P30 units:

- Plastic or wooden mallet
- Arbor press or vise
- Thin blade screwdriver
- Adjustable spanner wrench
- 3/8" Hex wrench
- 7/16" Wrench or socket
- Gear puller
- Penetrating oil

When installing or removing bearings from the shaft, the use of an arbor press is strongly recommended.

To disassemble the pedestal:

Refer to Figure 4-28 for reference to the numbered parts in the procedures below.

- Remove Bearing Frame Mounting Brackets (#31) by unscrewing Shoulder Screws (#33C) with a 3/8" hex wrench.
- Remove the four (4) Hex Capscrews (#33B) that hold the Bearing Frame Housing (#3) to the End Bell (#101), using a 7/16" wrench or socket.
- Position assembly horizontally on workbench. Holding bearing frame housing firmly, tap on the coupling end of shaft with rubber mallet until the assembly comes apart.

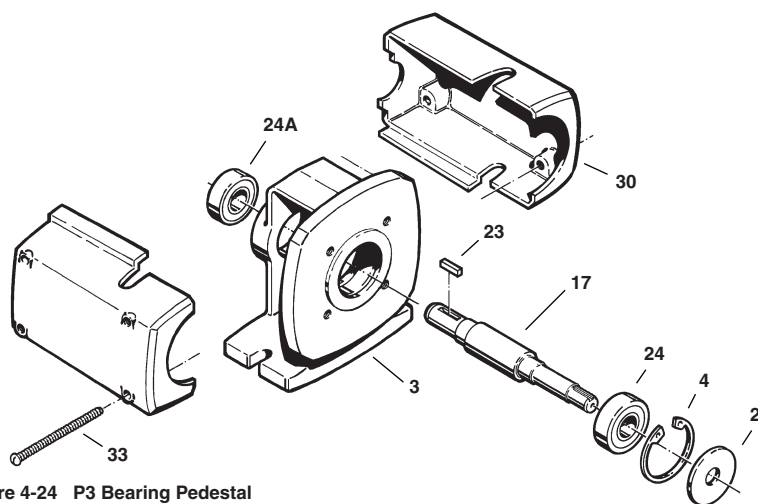

Figure 4-24 P3 Bearing Pedestal

- Remove guide rod nuts and guide rods from end bell.
- Remove Outboard Bearing (#24A) using a gear puller.
- With a spanner wrench, unscrew the Outboard Bearing Adjusting Nut (#110A) from the end bell.
- Support end bell, with motor mounting face up, and press out shaft / bearing assembly with arbor press. Remove Inboard Bearing Adjusting Nut (#110).
- Disengage bearing lockwasher tang from slot in Bearing Locknut (#38), using a thin blade screwdriver. Locknut and Bearing Lockwasher (#39) may now be removed from shaft. Grip shaft in the area between the two bearing surfaces only.
- Place shaft / bearing assembly in arbor press and remove the Inboard Bearing (#24).

4D Inspection of Components

Thoroughly clean all parts. All components should be examined for wear and corrosion. Replace any parts showing visible wear.

Check to be certain that a press fit still exists between the shaft and the bearings. New bearings, or at least cleaned and regreased bearings, are recommended.

Check the shaft for galling, pitting, and corrosion. Surface corrosion on the pump portion of the shaft must be removed so the seals will slide freely during assembly. The shaft

diameter should be no smaller than .002" below the nominal fractional seal sizes. Remove any nicks or burrs which may have occurred during disassembly. Reclean parts as necessary.

4E Reassembly (P3)

All parts should be visually inspected and cleaned or replaced as outlined in 4D above. It is recommended that the bearings be replaced any time the bearing pedestal is disassembled for service.

The following tools and equipment are needed for reassembly of P3 units:

- Arbor press
- Rubber or plastic mallet
- Internal snap ring pliers
- 3/4" X 6" piece of water pipe

To reassemble the bearing frame:

Refer to Figure 4-24 for reference to the numbered parts in the reassembly below.

- Using an arbor press, install the bearings on the shaft prior to installing the shaft into the pedestal. A steel "donut" with the proper inside diameter and outside diameter, refer to Chart 1, should be used between the arbor face plate and the lower bearing to insure proper installation, and to prevent bearing damage. The bearings must seat against the shoulder for proper alignment. Refer to Figure 4-25.

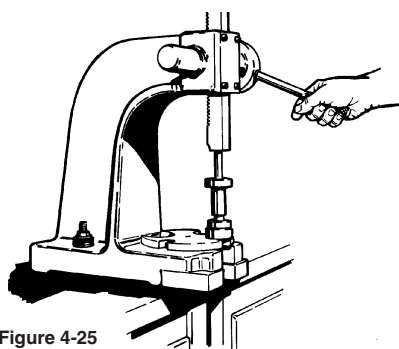

Figure 4-25

*Also refer to Alternate bearing installation procedures.

- Place the pedestal, pump mounting surface up, in a vise or suitable fixture and insert the bearing assembly. It should be possible to install the shaft assembly with firm thumb pressure. Refer to Figure 4-26. If more force is required, the butt end of a hammer handle or plastic mallet may be helpful. The shaft assembly should never be forced or driven in.

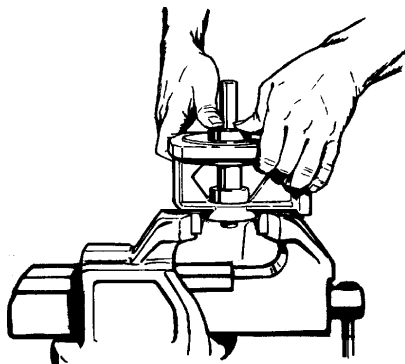

Figure 4-26

- Install the Snap Ring (#4) in the pump end of the pedestal. Be sure the snap ring is seated properly in the groove. The beveled edge of the ring should face away from the bearing.
- Install the Flinger (#21) over the snap ring. The bearing pedestal is now ready for pump and motor installation.

*Alternate bearing installation procedures.

If an arbor press is not available, the bearings may be installed on the shaft using the following procedure:

This procedure is not recommended and should only be used in an emergency situation.

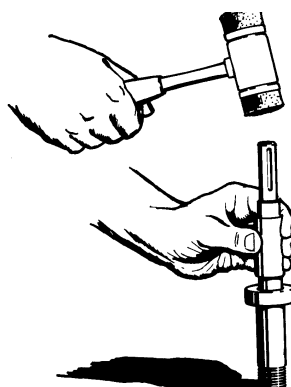

Figure 4-27

- Stand a piece of 3/4" pipe, with the threads cut off, on a workbench or similar flat surface, with the bearing placed on the correct shaft end.
- Insert the shaft into the pipe so the bearing is between the pipe

and the shoulder of the shaft. Refer to Figure 4-27.

- Using extreme caution, gently tap on the end of the shaft until the bearing rests against the shoulder. Never attempt to install the bearings by striking the outer race.
- Repeat steps 1-3 for the other bearing.

4F Reassembly (P30)

All parts should be visually inspected and cleaned or replaced as outlined in 4D above. It is recommended that the bearings be replaced any time the bearing pedestal is disassembled for service.

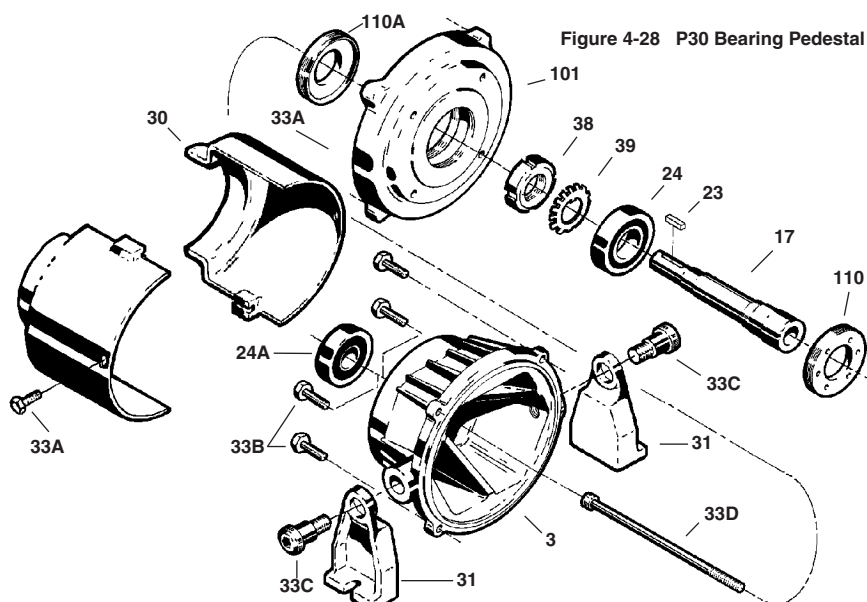

Figure 4-28 P30 Bearing Pedestal

P3 & P30 BEARING

KEY NO.	NAME / DESCRIPTION	Quantity	
		P-3	P-30
3	Bearing Pedestal	1	1
4	Snap Ring / Bearing Retaining	1	0
17	Shaft	1	1
21	Flinger	1	0
23	Key	1	1
24	Ball Bearing / Inboard	1	1
24A	Ball Bearing / Outboard	1	1
30	Coupling Guard	2	2
31	Bearing Frame Mounting Bracket	0	2
33	Capscrew	4	0
33A	Capscrew	0	2
33B	Hex Capscrew	0	4
33C	Shoulder Screw	0	2
33D	Thru Bolt - Shaft	0	1
38	Bearing Locknut	0	1
39	Bearing Lockwasher	0	1
101	End Bell	0	1
110	Bearing Adjusting Nut - Inboard	0	1
110A	Bearing Adjusting Nut - Outboard	0	1

The following tools and equipment are needed for reassembly of P30 units:

1. Arbor press
2. Drift punch.
3. Thin blade screwdriver
4. Spanner wrench
5. Rubber or plastic mallet
6. 1 1/2" X 8" piece of water pipe
7. 1 1/4" X 6" piece of water pipe
8. 7/16" wrench or socket
9. 3/8" hex wrench

To reassemble the bearing frame:

Refer to Figure 4-28 for reference to the numbered parts in the reassembly below.

1. Using an arbor press, install the Inboard Bearing (#24) on the Shaft (#17). A steel "donut" with the proper inside diameter and outside diameter, refer to Chart 1, should be used between the arbor face plate and the bearing to insure proper installation, and to prevent bearing damage. Bearing must seat against the shoulder for proper alignment.

*Also refer to Alternate bearing installation procedures.

2. Install Bearing Lockwasher (#39) on the shaft, aligning internal tang into keyway in shaft, and with external tangs facing away from bearing. Install Bearing Locknut (#38) on shaft, with beveled side facing toward bearing. Tighten snugly, using a drift punch if necessary, until a slot lines up with a tang on the lockwasher. Using a thin blade screwdriver, bend the tang into the slot in the locknut.
3. Thread Outboard Bearing Adjusting Nut (#110A) into bore inside the End Bell (#101). Adjusting nut should be approximately flush with the top of the bore.
4. Place end bell, pump mounting surface up, on the arbor press face plate. Press shaft assembly into bearing bore until the bearing rests against the adjusting nut. Thread Inboard Bearing Adjusting Nut (#110) into bore. (This adjusting nut has a left hand thread.) It is

not necessary to tighten the adjusting nuts completely until the pump has been assembled to the end bell, as some adjustment will be necessary.

5. Press shaft onto Outboard Bearing (#24A) with the arbor press. Bearing must seat against the shoulder in shaft for proper alignment.

***Alternate bearing installation procedures.**

If an arbor press is not available, the bearings may be installed on the shaft using the following procedure:

This procedure is not recommended and should only be used in an emergency situation.

1. Stand a piece of 1 1/2" pipe, with the threads cut off, on a workbench or other similar flat surface, with the bearing placed on the correct shaft end.
2. Insert the shaft into the pipe so the bearing is between the pipe and the shoulder of the shaft.
3. Using extreme caution, gently tap on the end of the shaft until the bearing rests against the shoulder. Never attempt to install the bearings by striking the outer race.
4. Continue previous assembly steps 2-4. Using a 1 1/4" piece of pipe, with the threads cut off, repeat alternate assembly steps 1-3 for the other bearing.

The end bell assembly is now ready to receive the pump assembly. Proceed to Section 4, M50 • L50 PUMP ENDS, 4H Reassembly Multistage on C30 Motors / P30 Bearing Frames before completing bearing frame assembly.

After pump is assembled to end bell assembly, it is recommended that the assembly be placed vertically on the pump outlet end for further assembly. Blocks can be used to steady the unit.

To complete the bearing frame assembly:

1. Place Bearing Pedestal (#3) housing (with large opening down) over the end bell assembly. Position the housing in such a way that the mounting bracket holes are perpendicular to the pump inlet. The ribbed portion of the housing should also face the pump inlet. With a soft rubber or plastic mallet, carefully tap the housing into place on the outboard bearing. Make sure that the lip on the housing enters the groove inside the end bell snugly.
2. Thread the four (4) Hex Capscrews (#33B) through the bearing pedestal and into the holes in the end bell. Tighten securely with a 7/16" wrench or socket.
3. Attach the Bearing Frame Mounting Brackets (#31) to the holes in the sides of the bearing frame housing with the Shoulder Screws (#33C), using a 3/8" hex wrench. Do not tighten until mounting the pump assembly to the metal base.

The bearing pedestal / pump assembly is now ready for motor installation.

4G Testing and Final Adjustments

P3 Units:

1. Check to be sure that the rotating assembly turns freely. Turn the shaft by hand. If it is tight or rough spots are encountered, it is likely that at least one of the bearings was damaged during disassembly/assembly operations, and will have to be replaced.
2. Look to make sure that the lip seals on the bearings are positioned properly in their grooves. Correct if necessary. As the bearings are turned, the grooves should appear wet with oil, but have no visible grease present.
3. Recheck the snap ring on the large bearing end on P3 units. It should be firmly in place, and no axial motion should result from gentle tapping on either end of

the shaft. (Use a soft mallet so shaft surfaces are not damaged.)

4. No adjustments are possible or required. Proceed with the appropriate pump end assembly operations. Refer to Section 4, Service - PUMP ENDS (Final testing is done after the pump end is in place.)

P30 Units:

1. Check to be sure that the rotating assembly turns freely. Turn the shaft by hand. If it is tight or rough spots are encountered, it is likely that at least one of the bearings was damaged during disassembly/assembly operations, and will have to be replaced.

2. Look to make sure that the lip seals on the bearings are positioned properly in their grooves. Correct if necessary. As the bearings are turned, the grooves should appear wet with oil, but have no visible grease present.
3. Refer to Section 4, Service - PUMP ENDS, 4I Testing and Final Adjustments.

M50 • L50 SERIES

5. Troubleshooting

FLEXIBLE COUPLED PUMPS CLOSE COUPLED PUMPS

- A. Failure to Pump
- B. Reduced Capacity
- C. Reduced Pressure
- D. Pump Loses Prime After Starting
- E. Excessive Power Consumption
- F. Pump Vibrates or is Noisy
- G. Mechanical Problems
- H. Seal Leakage

5A Failure to Pump

1. Pump not up to speed — Use Tachometer to determine actual RPM. Check voltage and wiring connections.
2. Pump not primed — Confirm that pump and all inlet piping are filled with fluid.
3. Discharge head too high — Install a pressure gauge at the pump discharge to determine the actual operating pressure. Compare readings with pump performance curve. A larger pump may be necessary.
4. Excessive suction lift — Relocate pump, supply tank, or both to minimize suction lift.
5. Wrong direction of rotation — Compare pump rotation with arrow on pump. Standard pumps rotate in a clockwise direction when looking at the shaft extension end or from the motor end on close-coupled pumps. Reverse two leads on a three-phase motor to change rotation. Check motor nameplate for single-phase operation.

6. Clogged suction line, strainer, or foot valve — Inspect and clean out if necessary.
7. Air pocket in suction line — Look for high spots in inlet piping system. Evacuate the system with a vacuum pump if necessary.

5B Reduced Capacity

1. Pump not up to speed — Use a tachometer to determine actual RPM. Check voltage and wiring connections.
2. Excessive suction lift — Relocate pump, supply tank, or both to minimize suction lift.
3. Insufficient NPSH — Relocate pump, supply tank, or both to improve NPSH available if possible. Increase suction pressure. Reduce fluid temperature. Select a pump with lower NPSH requirements.
4. Mechanical damage — Rotate the pump by hand to determine if there are tight spots. Broken or bent impeller vanes can sometimes be detected in this manner. If there is a suspicion of damage, remove the pump from service and disassemble for inspection.
5. Air leak in the suction line — Fill the system with fluid and hydrostatically test. Tighten connections or replace leaky components.
6. Air pockets in the suction piping — Operating the system at maximum flow conditions will usually clear the lines. Evacuate

the system with a vacuum pump if necessary.

7. Suction lines, strainer, or foot valve too small or clogged — Inspect and clean out as necessary. Fittings and lines should be at least equal to the pump suction size.
8. Discharge head too high — Install a pressure gauge at the pump discharge to determine the actual operating pressure. Compare readings with pump performance curve. A larger pump may be necessary.
9. Excessive wear — If a pump had previously performed satisfactorily and now gives evidence of reduced performance, it should be disassembled and examined for wear after the simpler possible problems have been investigated.

5C Reduced Pressure

1. Pump not up to speed — Use a tachometer to determine actual RPM. Check voltage and wiring connections.
2. Air or vapor in liquid — Install a separator in the suction line. Check the seal on the inlet end of the pump to determine if air is being drawn in. Hydrostatically test the system to insure that there are no leaks.
3. Mechanical wear or damage — Rotate the pump by hand to determine if there are tight spots. Broken or bent impeller vanes can sometimes be detected in this manner. If there is a

suspicion of damage or wear, remove the pump from service and disassemble for inspection. Look for wear on the impeller and channel rings.

4. System head less than expected — Replace pump with higher capacity unit or add a valve or orifice to increase line resistance.

5D Pump Loses Prime After Starting

1. Leak in suction line — Fill the system with fluid and hydrostatically test. Tighten connections or replace leaky components.
2. Air entering pump through inlet seal or “O” rings — Hydrostatically test the pump and look for leaks. Replace faulty seals or “O” rings.
3. Insufficient NPSH or too much suction lift — Relocate pump, supply tank, or both to improve inlet conditions. Increase suction pressure. Reduce fluid temperature. Select a pump with lower NPSH requirements.

5E Excessive Power Consumption

1. Speed too high — Check RPM with tachometer.
2. Discharge head too high — Install a pressure gauge at the discharge to determine the actual operating pressure. Compare readings with pump performance curve. A different pump, motor, or both may be necessary.
3. Specific gravity or viscosity too high — Check fluid involved. A different motor may be necessary.
4. Mechanical damage — Turn pump over by hand. After a few days run-in period, all models should turn over by hand with no tight spots. An exception to this is when the pump has been idle for some time. In this case, run the pump for a few hours before checking for tight spots.

If there is a suspicion of damage, remove the pump from service and disassemble for inspection.

5. Pump not fully “broken in” — It is normal for new pumps to consume higher than normal current during the break-in period. If high power consumption persists beyond a few weeks, it is unlikely that further operation will reduce consumption.
6. Pump not properly adjusted — Loosen all nuts on pump exactly one turn. Follow the instructions in Section 4F Testing and Final Adjustments, for repositioning fasteners.

5F Pump Vibrates Or Is Noisy

1. Pump and motor are misaligned — Follow the instructions in Section 2D Alignment, for proper alignment.
2. Insecure mounting — Follow instructions in Section 2, 2B Foundation.
3. Piping load on pump — Install piping supports and check to see that there is no strain on the pump.
4. Mechanical damage — If mechanical damage is suspected, check first to determine if the pump turns freely. Disassemble for inspection if tight spots are found.
5. Pump has a high pitched whine — This is typical of a regenerative turbine pump. The intensity should increase as pressure increases. Over a period of a few weeks the noise level will diminish and will be noticeably quieter as it approaches a “run-in” condition.

5G Mechanical Problems

1. Short bearing life — Bearings damaged due to leaky seals. Coupling misalignment. Piping load on pump. RPM or pump pressure too high.

2. Pump locked up — Pump dried out and close clearance areas rusted. Follow installation instructions for loosening the pump. Foreign material in pump. Flush out. Disassemble if flushing is not successful.
3. Pump leaks — Seal or “O” rings are usually the problem. Disassembly and replacement is the solution if tightening the thru bolts has no effect.

5H Seal Leakage

1. Worn seat or rotating element — Seals will last many years operating on cold clear water or other fluids with reasonable lubricity. Particles, even microscopic, increase normal wear rates. Temperatures near the fluid’s boiling point can reduce lubricity, which in turn increases wear. Some chemicals will erode the seal faces or plate out on the faces producing an abrasive effect. Immediate seal replacement is recommended when leaks become evident, since bearings are quickly ruined when exposed to moisture. Severe mechanical damage results when the bearings fail.
2. Improperly installed seat or rotating element — If a seal has recently been replaced, look for a missing “O” ring/cup around the seat, or a seat that was installed cocked or backwards. The smooth surface should face the rotating element. The rotating element may be in backward or improperly positioned. Refer to the appropriate seal diagrams and instructions to confirm the correct seal orientation. Rotating elements sometimes stick in the wrong position if left partially assembled for some time. Make sure a rotating element can be moved axially on the shaft before closing up the pump, and then make the final adjustments as soon as possible.
3. Seat broken during assembly — Ceramic seats are particularly vulnerable to damage. Carefully

follow reassembly instructions for seals. Seals on flex-coupled units can be damaged by excessive hammering when installing the coupling onto the shaft extension.

4. Pitted shaft under the seal — Reusing a shaft or sleeve when repairing a pump is the probable cause of this problem. The seal rotating element can produce a pitted surface underneath its elastomer portion during normal use. This is normally

not a problem for the first seal assembly since the elastomer is conforming as this action occurs. A new seal can leak before it conforms if the pits are large enough. If any pits are visible to the unaided eye, shaft or sleeve replacement is advised.

M50 • L50 SERIES

6. Parts and Repair Services

- A. Parts
- B. Repair Service
- C. Warranty Service
- D. Motors, Mechanical Seals, and Accessories

6A Parts

Repair parts may be obtained through your local Authorized MTH Pumps Representative or Distributor who can be found in the yellow pages or by contacting MTH Pumps at:
401 W. Main St. • Plano, IL 60545
Phone: 630-552-4115
Fax: 630-552-3688.

6B Repair Services

Repair service for an MTH pump should be obtained from the company through which it was purchased.

In the event this is not possible, the name and phone number of a nearby MTH representative or distributor may be obtained by contacting MTH Pumps. In the event that it is necessary to return the pump to the factory for repairs, remove all accessories attached to the pump. We cannot accept responsibility for their safe removal, storage, and return.

6C Warranty Service

All requests for warranty claims should be made through the company from which the pump was purchased or supplied. Complete details on what is wrong with the pump must be provided along with information on the system in which it is installed. Refer to the MTH Pumps

Limited Warranty statement. Return authorization must be obtained prior to returning any equipment.

6D Motors, Mechanical Seals, and Accessories

Repair or replacement service on motors, mechanical seals, relief valves, or other accessories should be obtained from the manufacturer of these components. MTH does not carry replacement parts and is not authorized to render repair service on these components. Replacement mechanical seals are stocked at MTH and are always available insofar as possible for immediate shipment. Warranty service, as well as expert application information can be obtained from your local seal manufacturer's sales office.

M50 • L50 SERIES

7. Limited Warranty

All requests for warranty claims should be made through the company from which the product was purchased or supplied. Complete details on what is wrong with the product must be provided along with information on the system in which it is installed. Refer to the MTH Pumps Limited Warranty statement below for more information. Return authorization must be obtained prior to returning any equipment.

MTH Tool Company, Inc. / MTH Pumps, hereinafter referred to as "MTH", warrants for a period of twelve (12) months from the date of shipment ("The Warranty Period"), that the products manufactured by it will be free from defects in material and workmanship. MTH will correct defects in material or workmanship which may develop in its products under proper or normal use during the Warranty Period and under the conditions of this Warranty. This Warranty does not extend to anyone except the original consumer-purchaser. Damage to the product due to improper handling, improper storage, improper maintenance, or improper application is not covered

by this Warranty. Warranty claims for special order items or accessories not manufactured by MTH (such as motors, valves, or mechanical seals) should be directed to those who manufactured the item. MTH will repair or replace, at its option and expense, its products proved to be defective after examination by an authorized representative of MTH. The defective Product must be returned, transportation prepaid, to the factory at Plano, Illinois, USA. Disassembly of the product (especially pumps) impairs determination of reasons for failure and shall be cause for voiding this Warranty. The Product, repaired or replaced, will be shipped F.O.B. MTH's factory. **This is MTH's sole warranty. MTH makes no other warranty of any kind, express or implied, and all implied warranties of merchantability and fitness for a particular purpose which exceed MTH's aforesaid obligations are hereby disclaimed by MTH and excluded from this warranty.** MTH neither assumes nor authorizes any person to assume for it, any other obligation in connection with the sale of the Product and any enlargement of

this Warranty by a purchaser shall be for its own account and its exclusive responsibility. This Warranty shall not apply to any Product or parts of Products which: (a) have been repaired, assembled, or altered outside of MTH's factory, in any manner; or (b) have been subjected to misuse, negligence or accident; or (c) have been used in a manner inconsistent with MTH's printed instructions, specifications, or the customer supplied application specification; or (d) have been damaged due to defective power supply or faulty installation. **MTH shall not be liable for incidental and consequential losses and damages under this express warranty, any applicable implied warranty, or claims for negligence, except to the extent that this limitation is found to be unenforceable under the applicable State law. Some States do not allow the exclusion or limitation of incidental or consequential damages, so the above limitation or exclusion may not apply to you. This warranty gives you specific legal rights, and you may also have other rights, which vary from State to State.**

Order Online: www.PumpCatalog.com



MTH PUMPS

401 West Main Street • Plano, IL 60545-1436
Phone: 630-552-4115 • Fax: 630-552-3688
Email: SALES@MTHPUMPS.COM
<http://WWW.MTHPUMPS.COM>



WARNING:
CANCER AND REPRODUCTIVE HARM -
WWW.P65WARNINGS.CA.GOV