

IOM

INSTALLATION OPERATION
& MAINTENANCE

PDM100 - PDM300

1, 1-1/2, 2, AND 3 INCH
PULSATION DAMPENERS

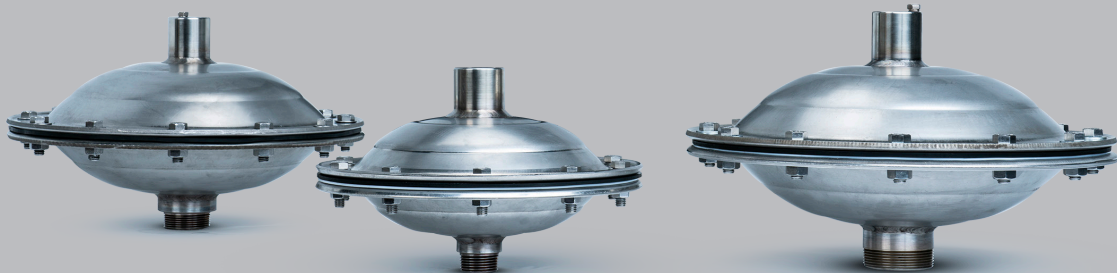

TABLE OF CONTENTS

SECTION 1	WARNINGS, DANGERS AND CAUTIONS	3
SECTION 2	MODEL DESIGNATION MATRIX	4
SECTION 3	DIMENSIONAL DRAWINGS	5
SECTION 4	INSTALLATION, TROUBLESHOOTING, AND MAINTENANCE	
	INSTALLATION	6-7
	OPERATION	6
	TROUBLESHOOTING	6
	MAINTENANCE	6
SECTION 5	REPAIR AND ASSEMBLY	
	WET END REMOVAL.....	8
	WET END ASSEMBLY	9-10
	TORQUE SPECIFICATIONS.....	11
SECTION 6	EXPLODED VIEWS AND PARTS LISTS	12-13
SECTION 7	REPAIR KITS	14

CAUTIONS — READ FIRST!

READ THESE WARNINGS AND SAFETY PRECAUTIONS PRIOR TO INSTALLATION OR OPERATION. FAILURE TO COMPLY WITH THESE INSTRUCTIONS COULD RESULT IN PERSONAL INJURY AND OR PROPERTY DAMAGE. RETAIN THESE INSTRUCTIONS FOR FUTURE REFERENCE.

⚠ WARNING This product can expose you to chemicals including Nickel, Chromium, Cadmium, or Cobalt, which are known to the State of California to cause cancer and/or birth defects or other reproductive harm. For more information, go to www.P65Warnings.ca.gov.

⚠ WARNING Pump, valves and all containers must be properly grounded prior to handling flammable fluids and/or whenever static electricity is a hazard.

⚠ WARNING Prior to servicing the pump and dampener, ensure that the air and fluid lines are closed and disconnected. While wearing personal protective equipment, flush, drain and process liquid from the pump and dampener in a safe manner.

⚠ CAUTION The temperature of the process fluid and air input must be no more than 36°F (20°C) less of the maximum temperature allowed for the appropriate non-metallic material. See the list of temperatures below for each material's maximum recommended temperature:

PTFE with Buna-N Back: 40°F to 180°F (4°C to 82°C)

Temperature limits are solely based upon mechanical stress and certain chemicals will reduce the maximum operating temperature. The allowable temperature range for the process fluid is determined by the materials in contact with the fluid being pumped. Consult a chemical resistance guide for chemical compatibility and a more precise safe temperature.

⚠ WARNING Prevent static sparking. If static sparking occurs, fire or explosion could result. Pump, valves and containers must be grounded to a proper grounding point when handling flammable fluids and whenever discharge of static electricity is a hazard.

⚠ CAUTION Do not lubricate air supply.

⚠ CAUTION Do not connect a compressed air source to the exhaust port of the pump.

⚠ WARNING Use only with liquid process fluid.

⚠ WARNING Maintenance must not be performed when a hazardous atmosphere is present.

⚠ CAUTION Do not exceed 120 psig (8.2 bar) air-inlet pressure.

⚠ WARNING = Hazards or unsafe practices which could result in severe personal injury, death or substantial property damage

⚠ CAUTION = Hazards or unsafe practices which could result in minor personal injury, product or property damage.

⚠ CAUTION Do not operate with a positive suction pressure.

⚠ CAUTION Ensure all wetted components are chemically compatible with the process fluid and the cleaning fluid.

⚠ CAUTION Ensure dampener is thoroughly cleaned and flushed prior to installation into a process line.

⚠ CAUTION Always wear Personal Protective Equipment (PPE) when operating pump.

⚠ CAUTION Before any maintenance or repair is attempted, the compressed air line to the dampener and pump should be disconnected and all air pressure allowed to bleed from the system. Disconnect all intake, discharge, and air lines. Drain the dampener, allowing any fluid to flow into a suitable container.

⚠ CAUTION Blow out air line for 10 to 20 seconds before attaching to pump to make sure all pipeline debris is clear. Use an in-line air filter. A 5µ (micron) air filter is recommended.

⚠ CAUTION Dampeners cannot be used in submersible applications.

⚠ CAUTION Ensure all hardware is set to correct torque values prior to operation.

⚠ WARNING The Safety Supplement document is a part of the manual. Please refer to the Safety Supplement document for a complete list of safety considerations including considerations for safe operation and maintenance of pumps marked for ATEX environments before starting the pump.

MODEL DESIGNATION MATRIX

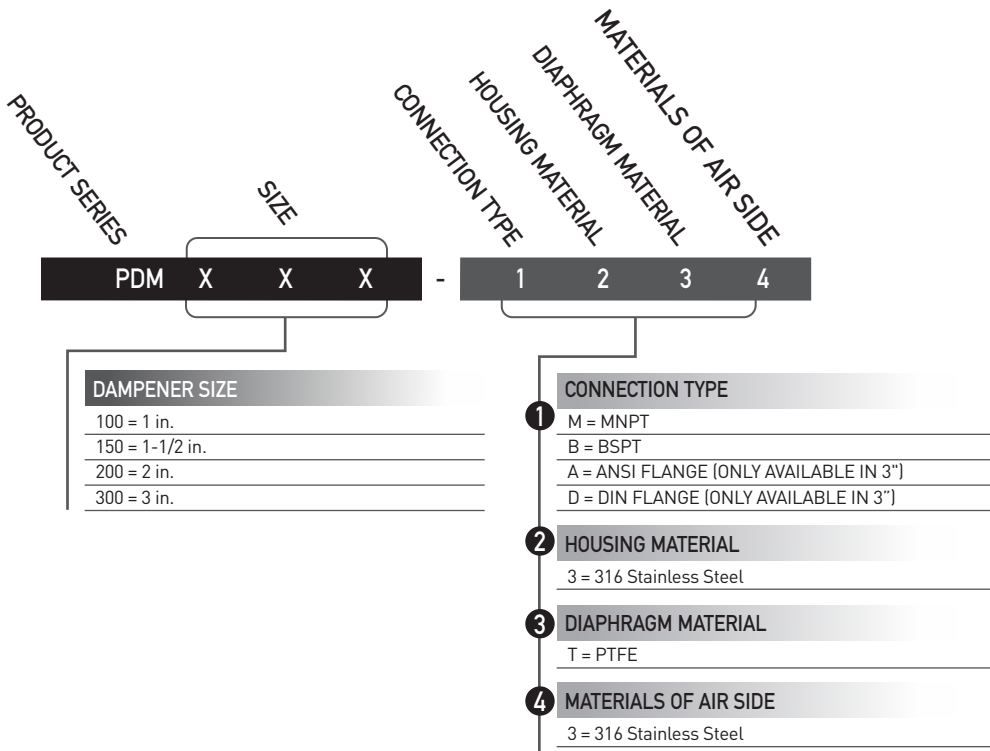

PULSATION DAMPENER DIMENSIONS

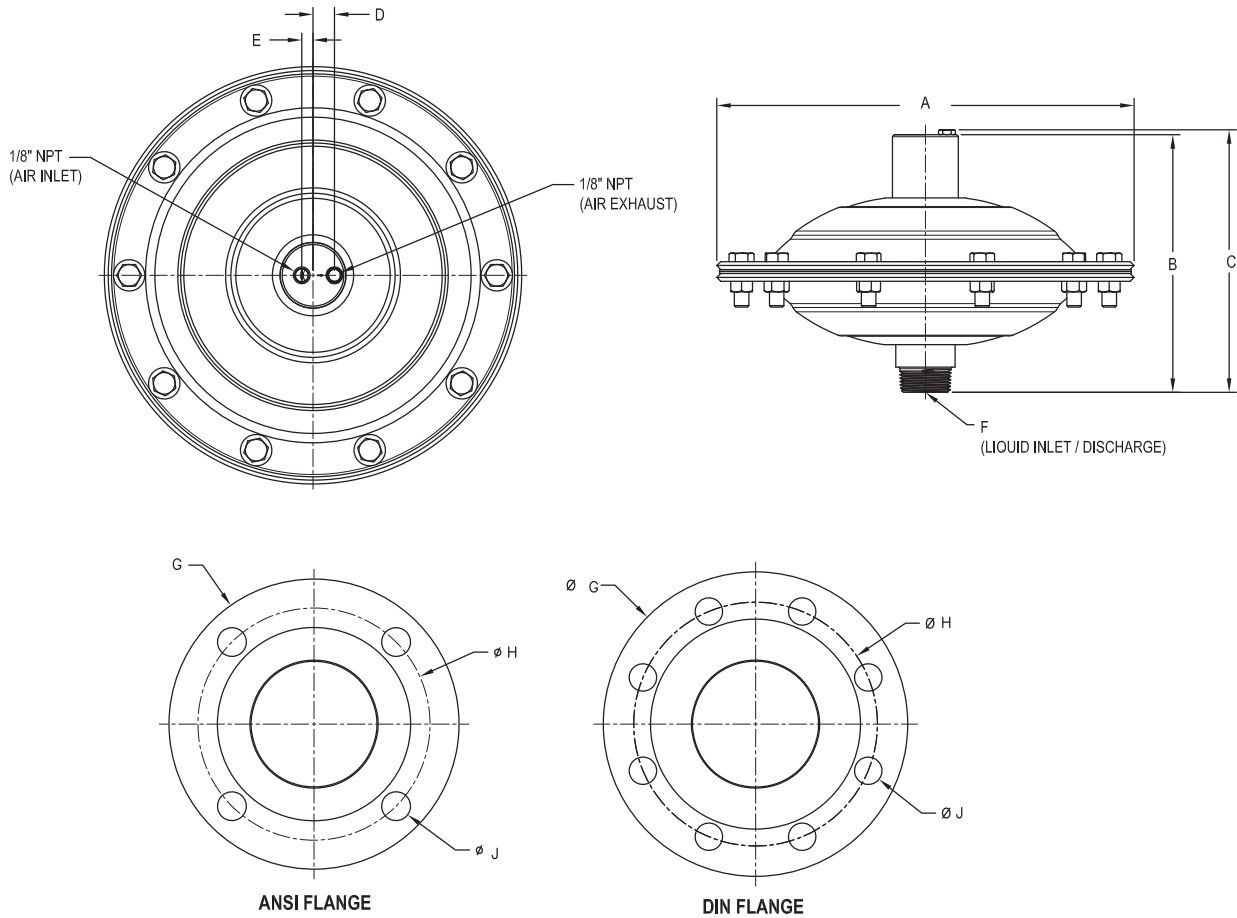

inch (mm)	A	B	C	D	E	F	G	H	J
PDM100	10.8 (274) DIA.	6.7 (169)	6.8 (172)	0.6 (14)	0.3 (7)	1" NPT (BSPT)	N/A	N/A	N/A
PDM150	14.2 (361) DIA.	8.7 (220)	8.8 (224)	0.6 (14)	0.3 (7)	1-1/2" NPT (BSPT)	N/A	N/A	N/A
PDM200	14.2 (361) DIA.	8.7 (220)	8.8 (224)	0.6 (14)	0.3 (7)	2" NPT (BSPT)	N/A	N/A	N/A
PDM300	18.7 (474) DIA.	13.1 (333)	13.4 (340)	0.7 (19)	N/A	3" NPT (BSPT)	N/A	N/A	N/A
PDM300	18.7 (474) DIA.	13.1 (333)	13.4 (340)	0.7 (19)	N/A	3" ANSI	7.5 (191) DIA.	6.0 (152) DIA.	0.8 (19) DIA.
PDM300	18.7 (474) DIA.	13.1 (333)	13.4 (340)	0.7 (19)	N/A	3" DIN	7.9 (200) DIA.	6.3 (160) DIA.	0.7 (18) DIA.

INSTALLATION, TROUBLESHOOTING AND MAINTENANCE

INSTALLATION

Before installing an PDM Series pulsation dampener into operation, review cautions and warnings as well as ensure that the materials of construction are suitable for the application. Refer to All-Flo's Chemical Resistance Guide for more information.

If installing an PDM Series pulsation dampener outside an All-Flo pump that is already in operation, be sure to remove the pump from service and thoroughly clean it prior to installation.

Install the PDM Series pulsation dampener as shown in the suggested installation illustration. A shut off valve on the inlet of PDM Series pulsation dampener will enable maintenance personnel to safely service the equipment. To maximize effectiveness install the PDM Series pulsation dampener as close as possible to the discharge of the pump. It is important to support the pipe immediately downstream from the PDM Series pulsation dampener. Use a tee connector on the pump air supply line and connect the line to the PDM Series 1/8" NPT inlet signaled by an arrow.

The PDM Series pulsation dampener consumes very little air, therefore, a 1/4" hose is more than adequate to supply enough air volume. When the air supply to the pump is shut down, the air to the PDM Series pulsation dampener will be shut off as well.

OPERATION

Before putting the pulsation dampener into operation, the housing bolts should be tightened as elements of construction tend to "settle".

For correct operation, the pulsation dampener will require its own air-supply line, taken from the air supply-of the pump. The pump and pulsation dampener are required to be connected to the same air pressure. Note that stop or regulating valves may be placed between the pump and pulsation dampener. The driving air has to be oil-free, dry and clean. The pulsation dampener requires a minimum counter pressure of at least 1 bar (14.5 psig) for optimal function. At startup, run the pump and pulsation dampener slowly prior to full operation. Once adjusted and full of fluid, the

pulsation dampener self-regulates for all changing operating conditions.

It is recommended to tighten housing bolts after a few hours of operation as well. Fixing bolts is necessary as well after long periods of stoppage, extreme temperature variations, or transport/dismantling.

CAUTION

DO NOT EXCEED 120 PSIG (8.2 BAR) AIR SUPPLY PRESSURE.

NOTE

In the event of a power failure, the shut-off valve should be closed, if the restarting of the pump is not desirable once power is regained.

TROUBLESHOOTING

When there is a significant drop in fluid discharge pressure, there will be a noticeable release of air through the small bleed hole in the air regulator body. This is how the pulsation dampener automatically adjusts itself for optimal suppression. This is a good way of verifying proper operation of the unit. If there is a continuous discharge of air out the bleed hole during steady fluid discharge pressure, the pulsation dampener is not functioning properly and should be inspected. The pulsation dampener air regulator body houses three O-rings which may need to be replaced.

MAINTENANCE

When pump disassembly is required, before starting to disassemble the pump, disconnect both the pump and the pulsation dampener from service. Thoroughly empty and clean both the pump and dampener before disassembly. Once maintenance is complete, refer to installation guidance prior to putting the pump and pulsation dampener back into service.

SUGGESTED INSTALLATION

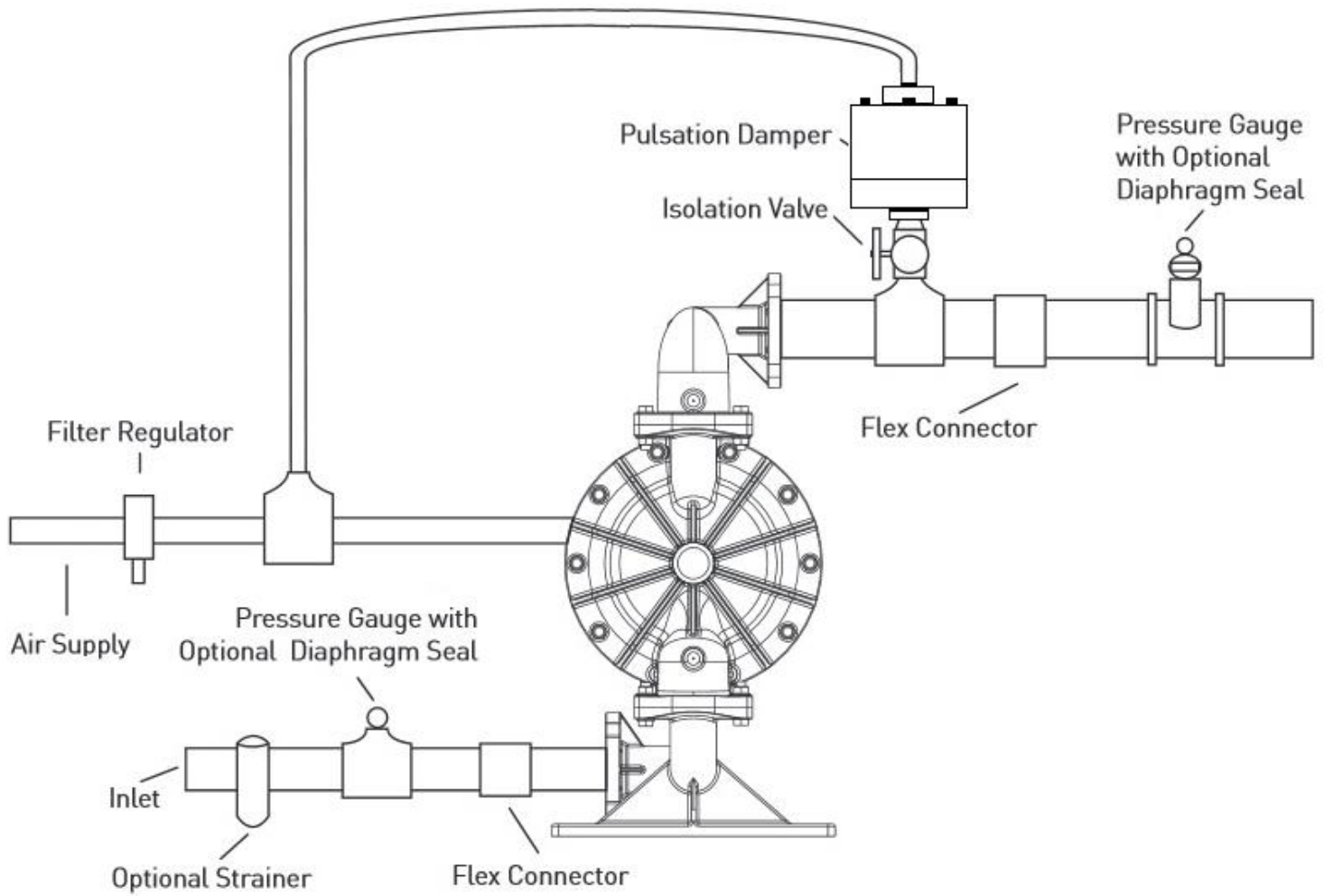

This illustration is a generic representation of an air operated double-diaphragm pump.

REPAIR AND ASSEMBLY

PULSATION DAMPENER WET END REMOVAL

TOOLS NEEDED

- 1) One O-ring Pick
- 2) One Allen Wrench, 1/8 Inch
- 3) One Socket Wrench, 9/16 Inch (PDM100), 5/8 Inch (PDM150, PDM200)
- 4) One Wrench, 9/16 Inch (PDM100), 5/8 Inch (PDM150, PDM200)
- 5) Retaining Ring Pliers (PDM300)

⚠ WARNING Prior to servicing the pump, ensure that the air and fluid lines are closed and disconnected. While wearing personal protective equipment, flush, drain and process liquid from the pump in a safe manner.

⚠ WARNING Maintenance must not be performed when a hazardous atmosphere is present.

⚠ WARNING For pump models with non-metallic manifolds, air valves, or chambers: When the relative humidity in the surrounding atmosphere is above 30%, the equipment must not be touched by personnel unless first wiped down with a damp cloth.

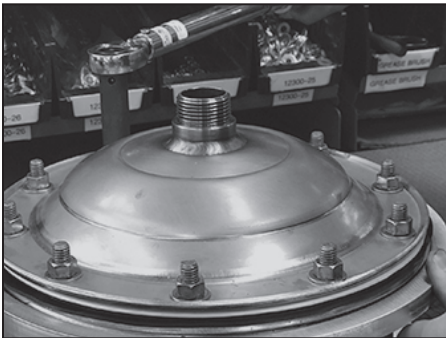

STEP 1

Loosen bolts with socket wrench.



STEP 2

Remove liquid chamber, inspect for damage, and set aside.

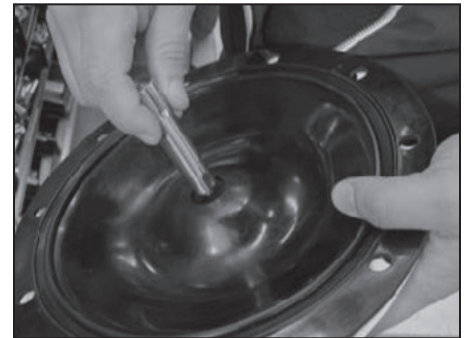

STEP 3

Pull diaphragm assembly (shaft and diaphragms) away from air chamber. Check O-rings, if they are worn or chemically attacked, they must be removed with an O-ring pick and replaced. Please refer to the exploded view and parts list for part numbers.

REPAIR AND ASSEMBLY

PULSATION DAMPENER WET END ASSEMBLY

TOOLS NEEDED

- 1) One O-ring Pick
- 2) One Allen Wrench, 1/8 Inch
- 3) One Socket Wrench, 9/16 Inch (PDM100), 5/8 Inch (PDM150, PDM200)
- 4) One Wrench, 9/16 Inch (PDM100), 5/8 Inch (PDM150, PDM200)
- 5) Retaining Ring Pliers (PDM300)

⚠ WARNING Prior to servicing the pump, ensure that the air and fluid lines are closed and disconnected. While wearing personal protective equipment, flush, drain and process liquid from the pump in a safe manner.

⚠ WARNING Maintenance must not be performed when a hazardous atmosphere is present.

⚠ WARNING For pump models with non-metallic manifolds, air valves, or chambers: When the relative humidity in the surrounding atmosphere is above 30%, the equipment must not be touched by personnel unless first wiped down with a damp cloth.

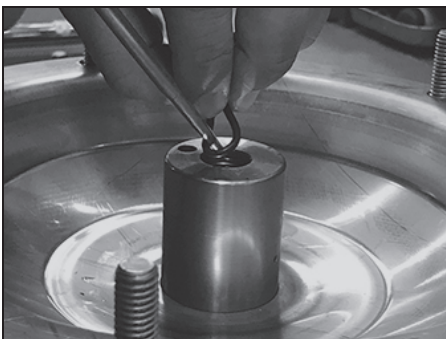

STEP 1

Install the control valve O-rings into the bottom of the shaft using the O-ring pick. Check that the O-ring is not damaged during installation.



STEP 2

Apply 2-3 drops of Vibra-Tite123 (or similar thread locking compound) to the shaft threads.

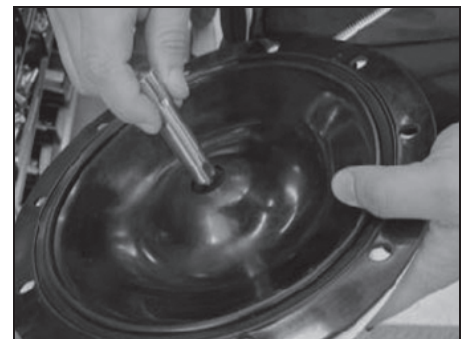

STEP 3

Install the shaft on the backing diaphragm until hand tight.



STEP 4

Apply 2-3 drops of Vibra-Tite123 (or similar thread locking compound) to the small threaded bore.

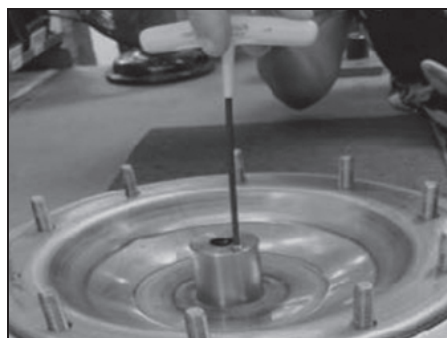

STEP 5

Install the set screw and tighten using the Allen Wrench. Be sure the screw does not get over-tightened.



STEP 6

Verify the shaft is clean and apply a coat of white EP grease to the shaft.



STEP 7

Install the back-up diaphragm and the shaft assembly into the air chamber. Align the bolt holes.

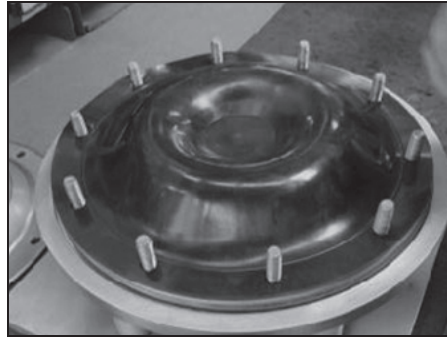

STEP 8

Begin installing the bolts and the flat washers.

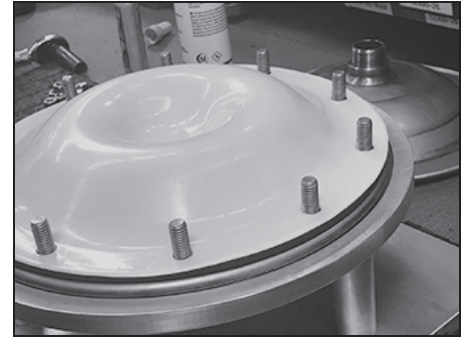

STEP 9

Place the primary diaphragm over the back-up diaphragm.



STEP 10

Install the liquid chamber on top of the primary diaphragm.



STEP 11

Place a flat washer at each bolt.

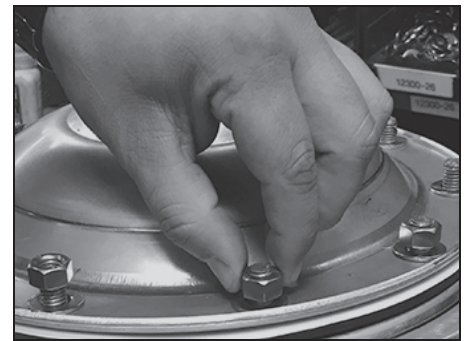

STEP 12

Apply anti-seize to the threads of each bolt. Install a nut on each bolt and hand tighten.

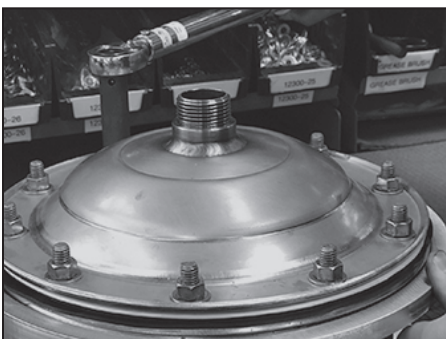

STEP 13

Using the socket wrench, tighten all nuts and bolts to applicable torque specifications identified on page 11.

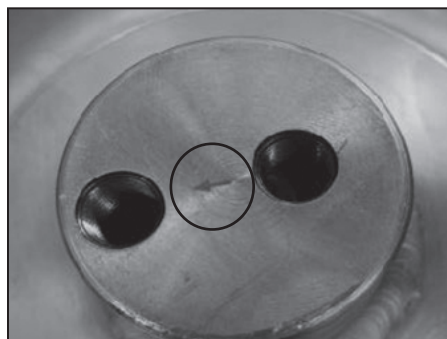

STEP 14

Note the arrow on the air chamber, pointing to the air inlet. When installing the breather vent, install it in the threaded hole opposite the air inlet.



TORQUE SPECIFICATION CHART

RECOMMENDED TORQUE SPECIFICATIONS

	1"	1-1/2"	2"	3"
Housing Bolts	19 ft-lbs (26 N-m)	30 ft-lbs (41 N-m)	30 ft-lbs (41 N-m)	30 ft-lbs (41 N-m)

EXPLODED VIEW & PARTS LIST

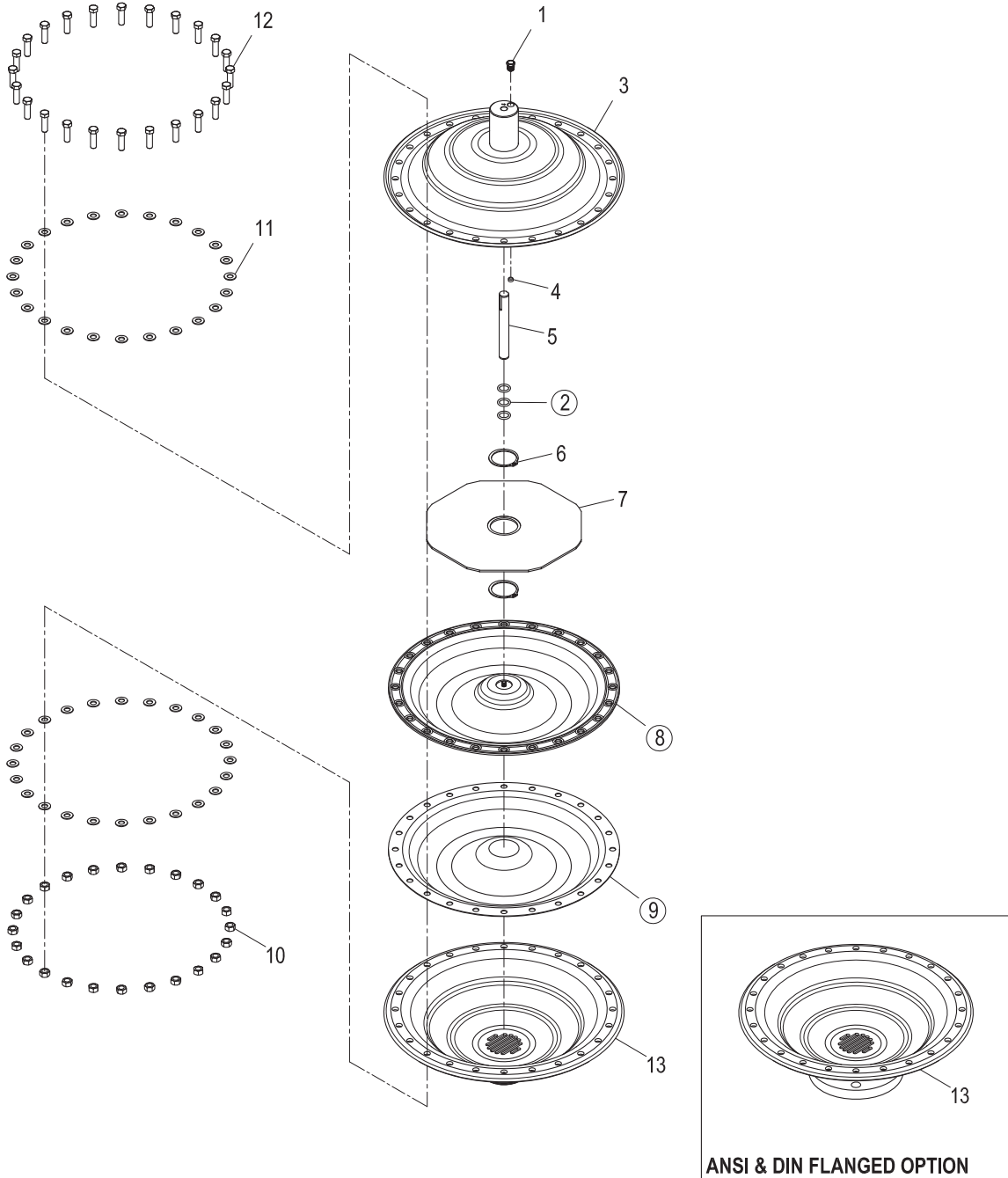

PARTS LIST

PUMP SIZE			PDM100	PDM150	PDM200	PDM300
ITEM	PC.	DESCRIPTION	PART NO.			
1	1	BREATHING VENT, 1/8" NPT	73-3241-06	73-3241-06	73-3241-06	N/A
		BREATHING VENT, 1/4" NPT	N/A	N/A	N/A	79-3241-03
2	3	O-RING, CONTROL VALVE [-114, Ø.612" x Ø.103"]	00-2870-52	00-2870-52	00-2870-52	N/A
		O-RING, CONTROL VALVE [-210, Ø.734" x Ø.139"]	N/A	N/A	N/A	02-3200-52
3	1	AIR CHAMBER ASSEMBLY	73-3645-99	74-3645-99	74-3645-99	79-3645-99
4	1	SCREW, SET [1/4"-20 X 1/4"]	73-6343-03	73-6343-03	73-6343-03	N/A
		SCREW, SET [3/8"-16 X 1/4"]	N/A	N/A	N/A	79-6343-03
5	1	SHAFT DAMPENER	73-3855-03	74-3855-03	74-3855-03	79-3855-03
6	1	RING, RETAINER 3"	N/A	N/A	N/A	79-2651-03
7	2	PLATE, CONTROL VALVE	N/A	N/A	N/A	79-8640-03
8	1	DIAPHRAGM, BACK-UP	73-1069-52	74-1069-52	74-1069-52	79-1069-52
9	1	DIAPHRAGM, PRIMARY	73-1045-55	74-1045-55	74-1045-55	79-1045-55
10	10	NUT, LOCK [3/8"-16]	99-6741-03	N/A	N/A	N/A
	12	HEX NUT [7/16"-14]	N/A	74-6427-03	74-6427-03	N/A
	24	HEX NUT [7/16"-14]	N/A	N/A	N/A	74-6427-03
11	20	WASHER, FLAT [Ø.812 X Ø.406 X .065]	04-6740-03	N/A	N/A	N/A
	24	WASHER, FLAT [Ø.922 X Ø.438 X .062]	N/A	74-6734-03	74-6734-03	N/A
	48	WASHER, FLAT [Ø.922 X Ø.469 X .080]	N/A	N/A	N/A	74-6734-03
12	10	Screw, HHC [3/8"-16 x 1 1/4"]	73-6190-03	N/A	N/A	N/A
	12	Screw, HHC [7/16"-14 x 1 1/4"]	N/A	74-6123-03	74-6123-03	N/A
	24	Screw, HHC [7/16"-14 x 1 1/2"]	N/A	N/A	N/A	79-6123-03
13	1	LIQUID CHAMBER ASSEMBLY (NPT)	73-4984-99	74-4984-99	75-4984-99	79-4984-99
	1	LIQUID CHAMBER ASSEMBLY (BSPT)	73-4984-99-14	74-4984-99-14	75-4984-99-14	79-4984-99-14
	1	LIQUID CHAMBER ASSEMBLY (ANSI)	N/A	N/A	N/A	79-4986-99
	1	LIQUID CHAMBER ASSEMBLY (DIN)	N/A	N/A	N/A	79-4986-99-504

REPAIR KITS

PULSATION DAMPENER PART NO.	KIT PART NO.
PDM100-M3T3	SET-PDM-100-T-3
PDM150-M3T3	SET-PDM-150-T-3
PDM200-M3T3	SET-PDM-200-T-3
PDM300-M3T3	SET-PDM-300-T-3
PDM100-B3T3	SET-PDM-100-T-3
PDM150-B3T3	SET-PDM-150-T-3
PDM200-B3T3	SET-PDM-200-T-3
PDM300-B3T3	SET-PDM-300-T-3
PDM300-A3T3	SET-PDM-300-T-3
PDM300-D3T3	SET-PDM-300-T-3

PULSATION DAMPENER REPAIR KIT

Pulsation Dampener repair kits are available for the PDM Series and consist of three shaft seals, one diaphragm, one back-up diaphragm, and one O-ring.



PSG

22069 Van Buren Street

Grand Terrace, CA 92313-5651 USA

P: +1 (440) 354-1700 F: +1 (440) 354-9466

all-flo.com

All-Flo is committed to the pursuit of designing and manufacturing the highest quality product available to industry. Since the beginning in 1986, All-Flo engineers have used their extensive knowledge of today's engineered materials, advanced air system logic and manufacturing techniques to develop the superior group of lube-free, air-operated diaphragm pumps found in this catalog. Every pump is performance engineered and quality built to provide trouble-free service under the toughest conditions.



Where Innovation Flows