

BALDOR® • ***RELIANCE***

Product Information Packet

ECP3774T

10HP,1760RPM,3PH,60HZ,215T,0748M,TEFC,F1

Part Detail							
Revision:	P	Status:	PRD/A	Change #:		Proprietary:	No
Type:	AC	Prod. Type:	0748M	Elec. Spec:	07WGX776	CD Diagram:	CD0005
Enclosure:	TEFC	Mfg Plant:		Mech. Spec:	07K374	Layout:	07LYK374
Frame:	215T	Mounting:	F1	Poles:	04	Created Date:	08-18-2006
Base:	RG	Rotation:	R	Insulation:	F	Eff. Date:	03-31-2015
Leads:	9#14					Replaced By:	
Literature:		Elec. Diagram:					

Nameplate NP3257E										
CAT.NO.	ECP3774T									
SPEC.	07K374X776G1									
HP	10	TE								
VOLTS	230/460									
AMP	25/12.5									
RPM	1760									
FRAME	215T						HZ	60		
SER.F.	1.15			CODE	H		DES	A		
RATING	40C AMB-CONT									
SN										
DE	6307						ODE	6307		
NEMA-NOM-EFF	92.4			PF	82					
G.MIN.EFF	91.0			CC	010A					
T. CODE	T3C			T=	160					
							PH	3		
							CL	F		

Nameplate NP3260E			
SPEC.	07K374X776G1		
D.E. BRG.	35BC03XP30X		
O.D.E. BRG.	35BC03XP30X		
GREASE	POLYREX EM		
RPM MAX	2700	MAX. KVAR	1.7
BLANK			
INV. TYPE	PWM		
T=	160		
C HP FR	60		
CT HZ FROM	1.3		
VT HZ FROM	0-		
HTR-VOLTS			
HTR-WATTS			
C HP TO	90		
CT HZ TO	60		
VT HZ TO	60		
HTR-AMPS			
MAX. SPACE HEATER TEMP.			

Parts List		
Part Number	Description	Quantity
SA147459	SA 07K374X776G1	1.000 EA
RA136506	RA 07K374X776G1	1.000 EA
37FN3002C01	EXFN, PLASTIC, 6.00 OD, 1.155 ID	1.000 EA
HW3201A05	3/8-16 EYEBOLT	1.000 EA
09CB1001A03G	CONDUIT BOX, MACH GRAY	1.000 EA
RM1017	LEAD SEPERATOR GASKET MODEL 307 1/8" THK	1.000 EA
51XW2520A12	.25-20 X .75, TAPTITE II, HEX WSHR SLTD	2.000 EA
11XW1032G06	10-32 X .38, TAPTITE II, HEX WSHR SLTD U	1.000 EA
HW3001B01	BRASS CUP WASHER, FOR #8 SCREW	1.000 EA
10XN2520S06	1/4 20X3/8 HX HD CAP S.S.	2.000 EA
WD1000B16	T&B CX70TN TERMINAL	2.000 EA
37EP1101C43G	TEFC 307 BRG, GRSR,RELIEF,.25-20 FH TAPS	1.000 EA
HW4500A01	1641B(ALEMITE)400 UNIV, GREASE FITT	1.000 EA
HA4051A00	PLASTIC CAP FOR GREASE FITTING	1.000 EA
HW4500A17	317400 ALEMITE GREASE RELIEF	1.000 EA
HA4054	SHORT T-DRAIN FITTING, .125" N.P.T.	1.000 EA
HW5100A08	W3118-035 WVY WSHR (WB)	1.000 EA
37EP1101A32G	PU ENDPLATE MACH	1.000 EA
HW4500A01	1641B(ALEMITE)400 UNIV, GREASE FITT	1.000 EA
HA4051A00	PLASTIC CAP FOR GREASE FITTING	1.000 EA
HW4500A17	317400 ALEMITE GREASE RELIEF	1.000 EA
HA4054	SHORT T-DRAIN FITTING, .125" N.P.T.	1.000 EA
XY3118A12	5/16-18 HEX NUT DIRECTIONAL SERRATION	4.000 EA
51XB1214A20	12-14X1.25 HXWSSLD SERTYB	1.000 EA

Parts List (continued)		
Part Number	Description	Quantity
07FH1001A01G	SPL FAN HOUSING, 307, W/GREASER, GRAY EP	1.000 EA
10XN2520A16	1/4-20 X 1 HEX HEAD CAP SCR, ZINC PLATED	3.000 EA
WD4100A02	DP-1000 HEYCO PLUG OR 62MP1000 MICRO PL	1.000 EA
09CB1504A01G	LIPPED CONDUIT BOX LID, MACH GRAY EPOXY	1.000 EA
09GS1001A01	GASKET, BOX LID, 1/8 THICK BLACK NEOPREN	1.000 EA
10XN2520A12	O1/4-20X 3/4 HEX HEAD CAP	2.000 EA
HW1001A25	LOCKWASHER 1/4, ZINC PLT .493 OD, .255 I	2.000 EA
HA1005A07	SLINGER, OD 2.25, ID 1.344, 307 BRG	1.000 EA
HW4600B33	V-RING SLINGER 1.375 X 1.890 X .35 VITON	1.000 EA
HW2501F21	KEY, 5/16 SQ X 2.375	1.000 EA
HA7000A02	KEY RETAINER RING, 1 1/8 DIA, 1 3/8 DIA	1.000 EA
MJ5001A27	32220KN GRAY SEALER *MIN BUY 4 QTS=1GAL	0.001 QT
85XU0407S04	4X1/4 U DRIVE PIN STAINLESS	2.000 EA
LB1115N	LABEL,LIFTING DEVICE (ON ROLLS)	1.000 EA
LB1002N	LABEL,MARINE DUTY (ON ROLLS)	1.000 EA
MJ1000A02	GREASE, POLYREX EM EXXON (USe 4824-15A)	0.050 LB
HA3104A32	THRUBOLT- 5/16-18 X12.750	4.000 EA
MG1025N19	WILKOFASST, 778.50, RELIANCE BLUE-GREEN	0.036 GA
LC0005E01	CONN.DIA./WARNING LABEL (LC0005/LB1119N)	1.000 EA
LB1449	DIV-2/NEC WARNING LABEL	1.000 EA
NP3257E	SS CP SUPER-E DIV-2 UL CSA-C US EEV PREM	1.000 EA
NP3260E	SS CP SUPER-E AUX DATA INFORMATION	1.000 EA
85XU0407S04	4X1/4 U DRIVE PIN STAINLESS	2.000 EA
07PA1011	PKG GRP, 07 CAST IRON PK1181	1.000 EA

MN416A01	TAG-INSTAL-MAINT no wire (1200/bx) 11/14	1.000 EA
----------	--	----------

Accessories		
Part Number	Description	Multiplier
37-1304	C FACE KIT	A8

AC Induction Motor Performance Data

Record # 25097 - Typical performance - not guaranteed values

Winding: 07WGX776-R016	Type: 0748M	Enclosure: TEFC
-------------------------------	--------------------	------------------------

Nameplate Data				460 V, 60 Hz: High Voltage Connection	
Rated Output (HP)	10			Full Load Torque	29.8 LB-FT
Volts	230/460			Start Configuration	direct on line
Full Load Amps	25/12.5			Breakdown Torque	87 LB-FT
R.P.M.	1760			Pull-up Torque	51.9 LB-FT
Hz	60	Phase	3	Locked-rotor Torque	57.5 LB-FT
NEMA Design Code	A	KVA Code	H	Starting Current	88.5 A
Service Factor (S.F.)	1.15			No-load Current	5.12 A
NEMA Nom. Eff.	92.4	Power Factor	82	Line-line Res. @ 25°C	0.973 Ω
Rating - Duty	40C AMB-CONT			Temp. Rise @ Rated Load	60°C
S.F. Amps				Temp. Rise @ S.F. Load	76°C
				Locked-rotor Power Factor	35
				Rotor inertia	1.18 LB-FT ²

Load Characteristics 460 V, 60 Hz, 10 HP

% of Rated Load	25	50	75	100	125	150	S.F.
Power Factor	44	67	78	82	84	85	83
Efficiency	90	92.9	93.1	92.5	91.4	90.1	91.8
Speed	1790	1781	1771	1762	1750	1739	1755
Line amperes	5.84	7.52	9.75	12.3	15.2	18.3	14

Performance Graph at 460V, 60Hz, 10.0HP Typical performance - Not guaranteed values

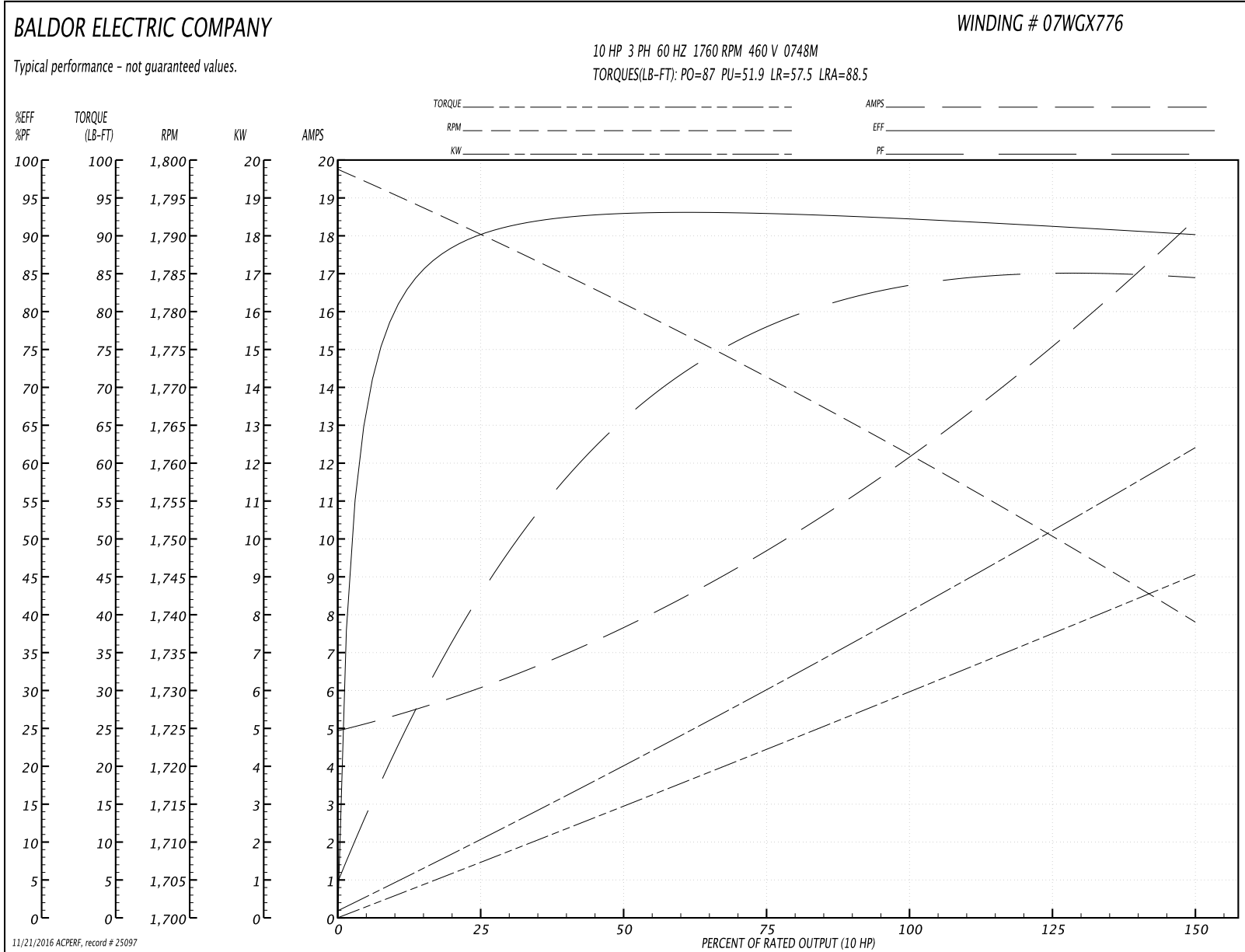

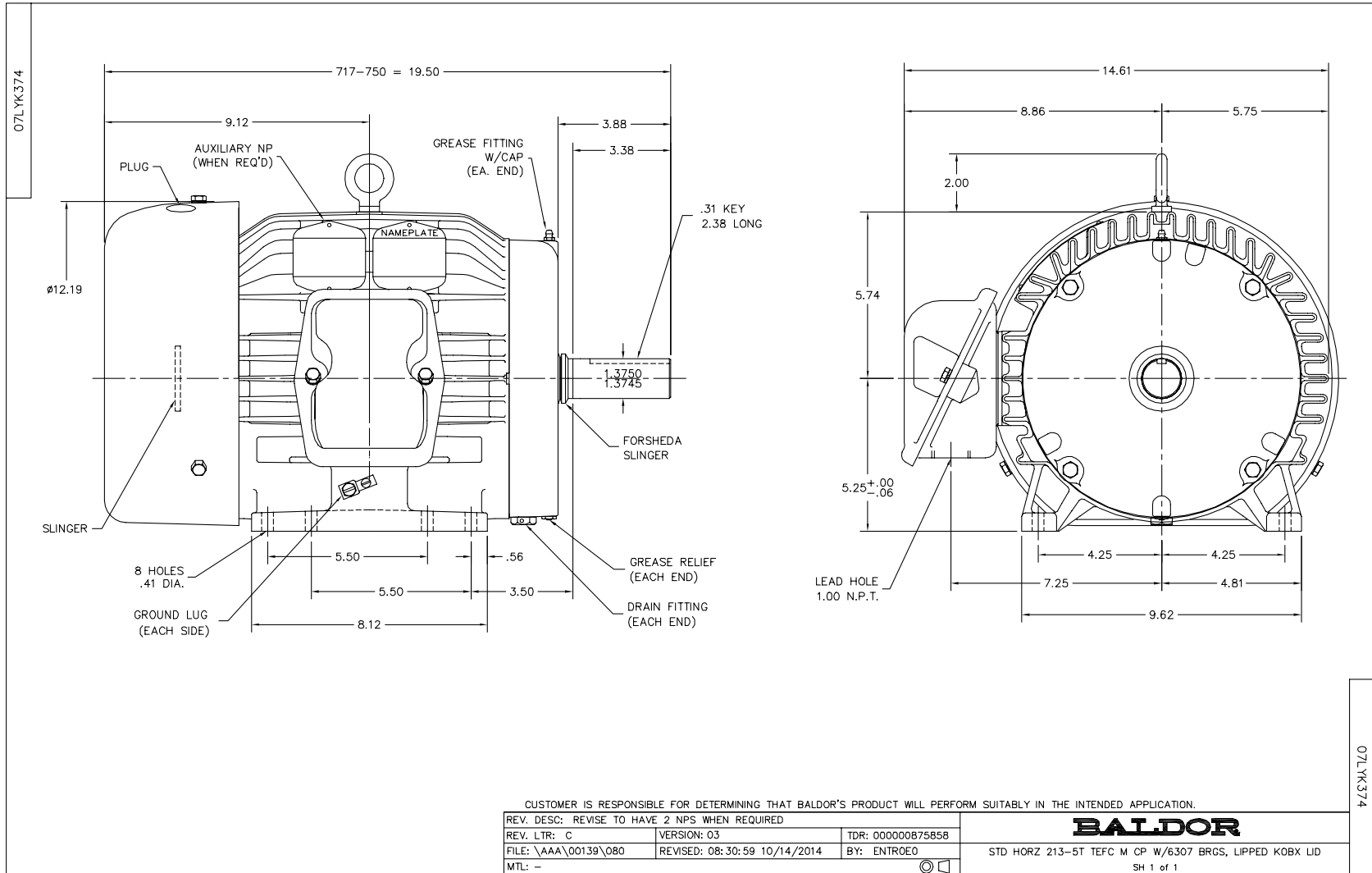

CD0005

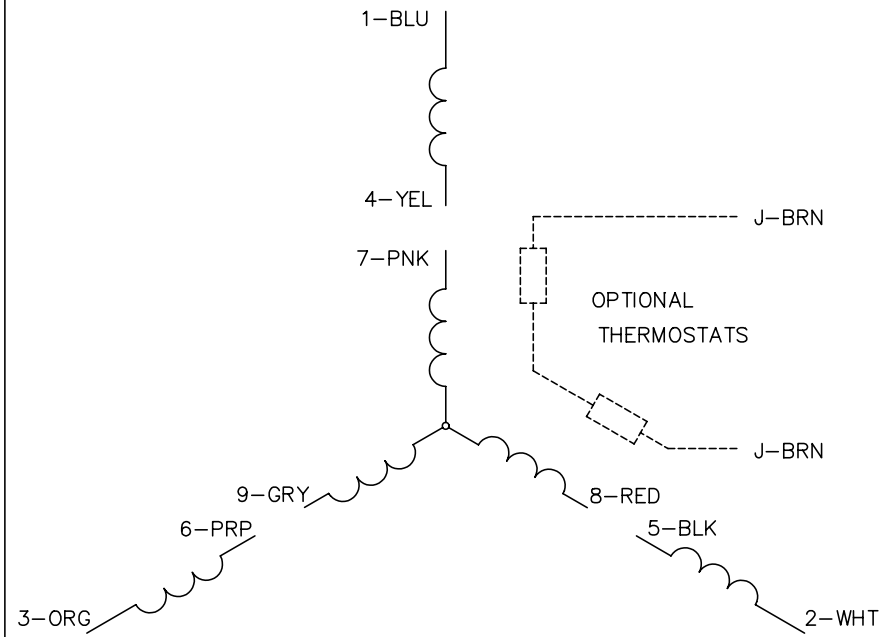

LOW VOLTAGE
(2Y)

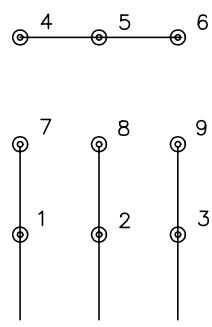

LINE

HIGH VOLTAGE
(1Y)

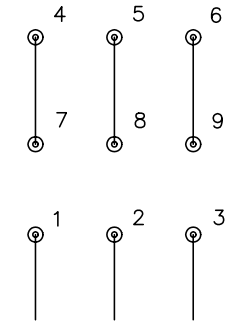

LINE

NOTES:

1. INTERCHANGE ANY TWO LINE LEADS TO REVERSE ROTATION.
2. OPTIONAL THERMOSTATS ARE PROVIDED WHEN SPECIFIED.
3. ACTUAL NUMBER OF INTERNAL PARALLEL CIRCUITS MAY BE A MULTIPLE OF THOSE SHOWN ABOVE.
4. LEAD COLORS ARE OPTIONAL. LEADS MUST ALWAYS BE NUMBERED AS SHOWN.

REV. DESC: REVISE TO SHOW OPTIONAL COLORS			
REV. LTR: E	BY: JLP	REVISED: 01/19/99 10:15	TDR: 0171435
90000		FILE: AAA00005140	MDL: -
		MTL: -	

BALDOR ELECTRIC Co.

3PH, DV, 9 LEADS

CD0005