

# **BALDOR**® • **RELIANCE**

## **Product Information Packet**

# **ECP82276T-5**

**7.5HP, 1180RPM, 3PH, 60HZ, 254T, 0954M, TEFC, F**

Part Detail							
Revision:	W	Status:	PRD/A	Change #:		Proprietary:	No
Type:	AC	Prod. Type:	0954M	Elec. Spec:	09WGZ844	CD Diagram:	CD0006
Enclosure:	TEFC	Mfg Plant:		Mech. Spec:	09G944	Layout:	09LYG944
Frame:	254T	Mounting:	F1	Poles:	06	Created Date:	12-06-2012
Base:	RG	Rotation:	R	Insulation:	F	Eff. Date:	03-08-2016
Leads:	3#12					Replaced By:	
Literature:		Elec. Diagram:					

Nameplate NP3190												
STK.NO.	ECP82276T-5		P/N			ENCLOSURE	TEFC					
SPEC.	09G944Z844G1		CC	010A	FRAME	254T		S/N				
HP	7.5		CLASS	F	HZ	60		ODE BRG	6309	DE BRG	6309	
RPM	1180	RPM MAX	1800		PH	3	DES	B		D.E. BRG.	45BC03X30X	
VOLT	575		KVA-CODE	H		O.D.E. BRG.	45BC03X30X					
AMP	8.4		MOTOR WEIGHT	302		GREASE	POLYREX EM					
RATING	40C AMB-CONT		MAX. KVAR	3.4		BLANK						
NEMA-NOM-EFF	91.7	# OF ROTOR BARS	27		SER.F.	1.15		IP	56			
G.MIN.EFF	90.2	# OF STATOR SLOTS	36		PF	71		INV.TYPE	PWM			
TEMP CODE	T3C		INVERTER-TEMP-CODE	180								
TEMP =	160		C HP FR	60		C HP TO	90					
CT HZ FROM	1		CT HZ TO	60								
HTR-VOLTS			HTR-AMPS			HTR-WATTS			MAX. SPACE HEATER TEMP.			
									VT HZ FROM	O	VT HZ TO	60

Parts List		
Part Number	Description	Quantity
SA255348	SA 09G944Z844G1	1.000 EA
RA242153	RA 09G944Z844G1	1.000 EA
WD1000B16	T&B CX70TN TERMINAL	1.000 EA
10XN2520K06	1/4-20 X 3/8" HX HD SCREWGRADE 5, ZINC P	1.000 EA
HW1002A63	WASHER, 5/8 HI-COLLAR SPRLCKWASHER	1.000 EA
09CB1002A12P	KOBX W/1.25 NPT LEAD HOLE & 2.38 MTG HOL	1.000 EA
09GS1010	GASKET, DWG, LEADWIRE SEPERATOR	1.000 EA
10XN2520K12	1/4-20 X.75 GRD 5	4.000 EA
HW1001A25	LOCKWASHER 1/4, ZINC PLT .493 OD, .255 I	4.000 EA
WD1000B16	T&B CX70TN TERMINAL	1.000 EA
10XN2520K06	1/4-20 X 3/8" HX HD SCREWGRADE 5, ZINC P	1.000 EA
HW1001A25	LOCKWASHER 1/4, ZINC PLT .493 OD, .255 I	1.000 EA
HA3400A39	STUD- 3/8-16 X 6.19 OAL HEX WELKER	4.000 EA
HW1001A38	LOCKWASHER 3/8, ZINC PLT .688 OD, .382 I	4.000 EA
12CB1503A01E	CONDUIT BOX LID, MACH, WITH LIP	1.000 EA
HW4500A20	1/8NPT SL PIPE PLUG	1.000 EA
HA4017A08	.125X3.50 GREASER EXTEN.	1.000 EA
HA4017A02	.125X2.50 GREASER EXTENS.F/S	1.000 EA
HW4019A01	PIPE COUPLING 1/8 NPT,STEEL,ZINC COATING	1.000 EA
HA4002A01	DRAIN PLUG STAINLESS STL	1.000 EA
HW4601A61	INPRO SEAL #1698-A-17120-0, VBXX 309 BRG	1.000 EA
HW5100A11	W3917-042 WVY WSHR (WB)	1.000 EA
10XN2520K36	1/4-20 X 2.25" HX HD SCRWGRADE 5, ZINC P	4.000 EA
09EP1118A01P	PUEP MACH, 309 BRG.INPRO SEALS-EPOXY PRI	1.000 EA

Parts List (continued)		
Part Number	Description	Quantity
HW4500A20	1/8NPT SL PIPE PLUG	1.000 EA
10XN3816K28	3/8-16 X 1.75 HEX HD CAP SCREW, GRADE 5	4.000 EA
HW1001A38	LOCKWASHER 3/8, ZINC PLT .688 OD, .382 I	4.000 EA
HA4002A01	DRAIN PLUG STAINLESS STL	1.000 EA
HW4601A61	INPRO SEAL #1698-A-17120-0, VBXX 309 BRG	1.000 EA
10XN2520K36	1/4-20 X 2.25" HX HD SCRWGRADE 5, ZINC P	4.000 EA
XY3816A12	3/8-16 FINISHED NUT	4.000 EA
HW1001A38	LOCKWASHER 3/8, ZINC PLT .688 OD, .382 I	4.000 EA
12GS1002	GASKET, CONDUIT BOX LID, NEOP	1.000 EA
10XN3118K16	5/16-18 X 1' GRADE #5, STL, ZINC PLATE	2.000 EA
HW1001A31	LOCKWASHER 5/16, ZINC PLT.591 OD, .319 I	2.000 EA
MJ5004A59	ADHESIVE LOCTITE #401 SURFACE INSENSITIV	0.010 EA
HW2501G25	KEY, 3/8 SQ X 2.875	1.000 EA
MJ5001A27	32220KN GRAY SEALER *MIN BUY 4 QTS=1GAL	0.031 QT
MJ5001A14	DYNAPRO SEAL, CP MOTORS VC#2508050 (603	0.023 EA
LB1115N	LABEL,LIFTING DEVICE (ON ROLLS)	1.000 EA
MN416A01	TAG-INSTAL-MAINT no wire (1000/bx) 11/14	1.000 EA
WD1000B49	T&B C73,RING TERMINAL 10-12 AWG 3/8 STUD	3.000 EA
09EP1118A02GP6	FREP MACH, 309 BRG. EPOXY PRIMER	1.000 EA
HW4500A21	1618BALEMITE FITTING 825 UNIVERSAL	1.000 EA
HA4051A00	PLASTIC CAP FOR GREASE FITTING	1.000 EA
HW4500A17	317400 ALEMITE GREASE RELIEF	1.000 EA
MJ1000A02	GREASE, POLYREX EM EXXON (USe 4824-15A)	0.080 LB
HW4500A03	GREASE FITTING, .125 NPT 1610(ALEMITE) 8	1.000 EA

Product Information Packet: ECP82276T-5 - 7.5HP,1180RPM,3PH,60HZ,254T,0954M,TEFC,F

HA4051A00	PLASTIC CAP FOR GREASE FITTING	1.000 EA
HW4500A17	317400 ALEMITE GREASE RELIEF	1.000 EA
09FN3001D01	EXTERNAL FAN, PLASTIC	1.000 EA
HW2500A25	WOODRUFF KEY USA #1008 #BLOW CARBON STEE	1.000 EA
51XB1214A20	12-14X1.25 HXWSSLD SERTYB	1.000 EA
09FH1000GE6	FAN COVER, CAST W/E-COAT & PAINT	1.000 EA
MG1025N19	WILKOFASST, 778.50, RELIANCE BLUE-GREEN	0.050 GA
85XU0407S04	4X1/4 U DRIVE PIN STAINLESS	4.000 EA
LB1449	DIV-2/NEC WARNING LABEL	1.000 EA
LB1119N	WARNING LABEL	1.000 EA
LC0006	CONNECTION LABEL	1.000 EA
NP3190	SS IEEE841 INV DIV-2 UL CSA-C US EEV	1.000 EA
40PA1005	PACKAGING GROUP, 09 STD	1.000 EA

**AC Induction Motor Performance Data**

Record # 47084 - Typical performance - not guaranteed values

<b>Winding:</b> 09WZ844-R004	<b>Type:</b> 0954M	<b>Enclosure:</b> TEFC
------------------------------	--------------------	------------------------

Nameplate Data				575 V, 60 Hz: Single Voltage Motor	
Rated Output (HP)	7.5			Full Load Torque	32.4 LB-FT
Volts	575			Start Configuration	direct on line
Full Load Amps	8.4			Breakdown Torque	90.2 LB-FT
R.P.M.	1180			Pull-up Torque	35.9 LB-FT
Hz	60	Phase	3	Locked-rotor Torque	52.7 LB-FT
NEMA Design Code	B	KVA Code	H	Starting Current	50.9 A
Service Factor (S.F.)	1.15			No-load Current	4.25 A
NEMA Nom. Eff.	91.7	Power Factor	71	Line-line Res. @ 25°C	1.6 Ω
Rating - Duty	40C AMB-CONT			Temp. Rise @ Rated Load	32°C
S.F. Amps				Temp. Rise @ S.F. Load	38°C

Load Characteristics 575 V, 60 Hz, 7.5 HP

% of Rated Load	25	50	75	100	125	150	S.F.
Power Factor	35	55	65	71	75	75	73
Efficiency	83.6	90.3	91.3	91.7	91.6	90.5	91.6
Speed	1196	1191	1188	1183	1177	1170	1179
Line amperes	4.67	5.65	6.81	8.37	10.1	12.5	9.41

Performance Graph at 575V, 60Hz, 7.5HP Typical performance - Not guaranteed values

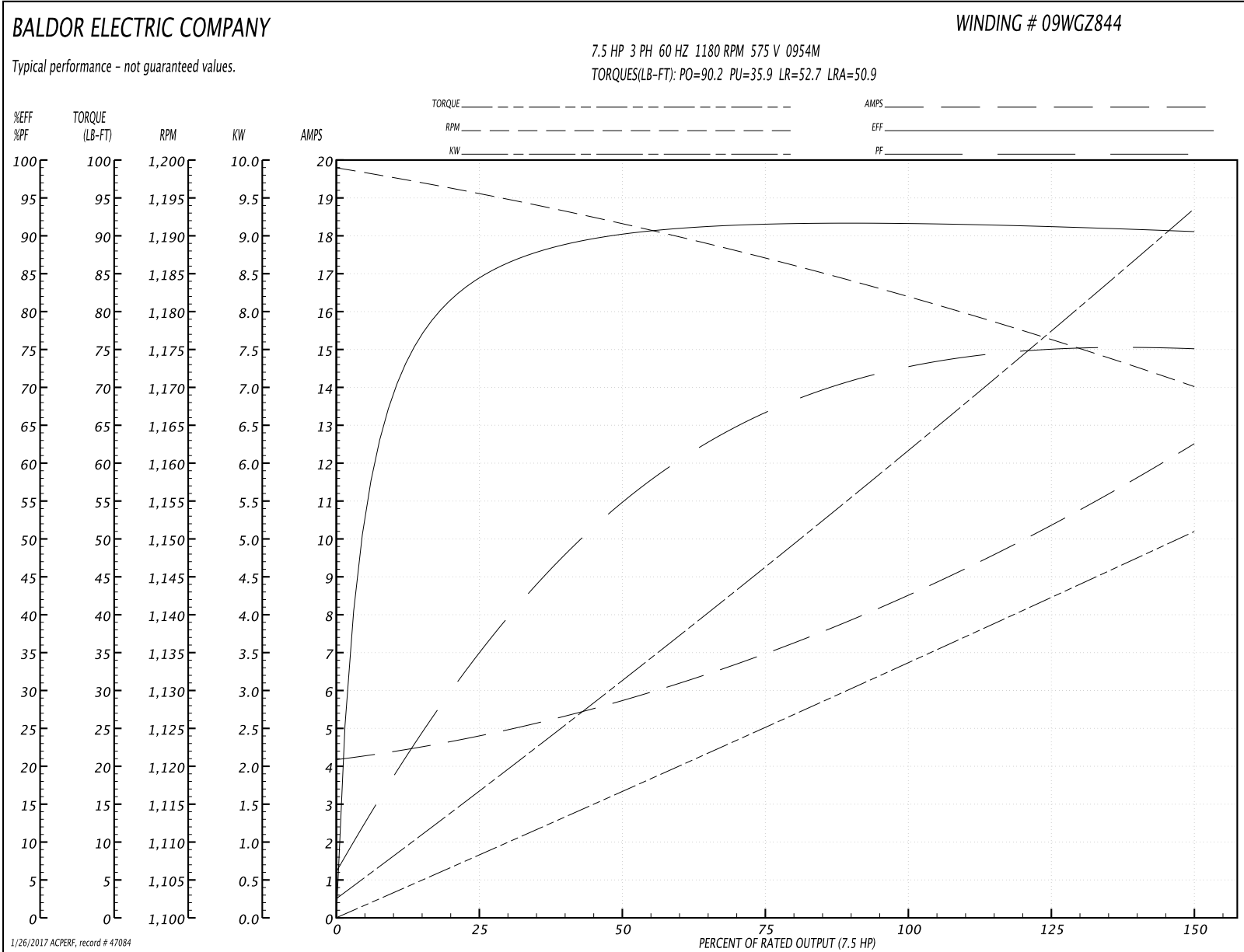

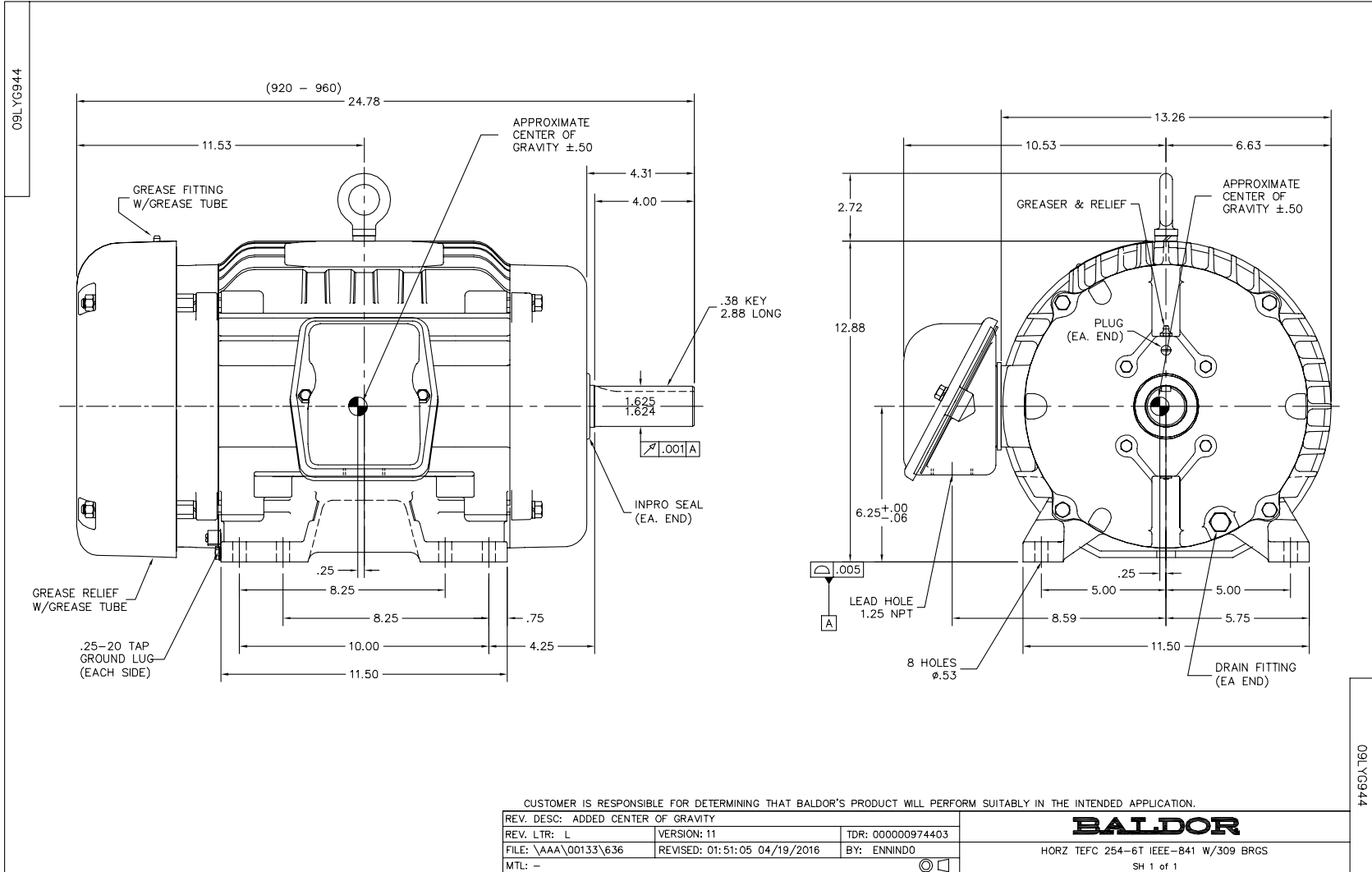

CD0006



NOTES:

1. THREE LEAD MOTOR MAY BE EITHER WYE CONNECTED OR DELTA CONNECTED.
2. INTERCHANGE ANY TWO LINE LEADS TO REVERSE ROTATION.
3. OPTIONAL THERMOSTATS ARE PROVIDED WHEN SPECIFIED.
4. ACTUAL NUMBER OF INTERNAL PARALLEL CIRCUITS MAY VARY.
5. LEAD COLORS ARE OPTIONAL. LEADS MUST BE NUMBERED AS SHOWN.

REV. DESC: REVISE TO SHOW OPTIONAL COLORS			
REV. LTR: D	BY: JLP	REVISED: 01/21/99 4:02	TDR: 0171435
9000D		FILE: AAA00005141	MDL: -
		MTL: -	

**BALDOR ELECTRIC Co.**

3PH, SV, 3 LEADS, WYE OR DELTA CONNECTED

CD0006