

# **BALDOR**® • ***RELIANCE***

## **Product Information Packet**

# **ECP844252T-4**

**250HP,3570RPM,3PH,60HZ,449TS,A44128M,TEF**

Part Detail							
Revision:	M	Status:	PRD/A	Change #:		Proprietary:	No
Type:	AC	Prod. Type:	A44128M	Elec. Spec:	A44WG1505	CD Diagram:	416820-036
Enclosure:	TEFC	Mfg Plant:		Mech. Spec:		Layout:	617427-066
Frame:	449TS	Mounting:	F1	Poles:	02	Created Date:	08-21-2012
Base:		Rotation:	PS	Insulation:	F	Eff. Date:	05-23-2016
Leads:	3#2/0 (02 per group)					Replaced By:	
Literature:		Elec. Diagram:					

Nameplate NP3237										
CAT NO	ECP844252T-4		SPEC NO.	P44G3982		DESIGN	B			
HP	250	AMPS	266	VOLTS	460	SF	1.15	DUTY	CONT	
FRAME SIZE	449TS	RPM	3570	HZ	60	AMB	40	PH	3	
D.E. BRG.DATA	6313	O.D.E. BRG.DATA	6313		TYPE	P	ENCL	TEFC	CODE	G
D.E. BRG.	65BC03J30X		POWER FACTOR	91		NEMA-NOM-EFFICIENCY	96.2			
O.D.E. BRG.	65BC03J30X		MAX CORR KVAR	23.0		GUARANTEED EFFICIENCY	95.8			
3/4 LOAD EFF.	96.6	IP	56	TEMP	=	215	VT HZ	0-60		
TEMP CODE	T2D	CT HZ	30-60		CHP HZ	60-75		INVERTER-TEMP-CODE		
INVERTER-TEMP-CODE	T2D		SER.NO.			MOTOR WEIGHT	2790			
SER.NO.										

Nameplate 000613007EX

CAT NO	ECP844252T-4	SPEC NO.	P44G3982
NO. ROTOR BARS	40	GREASE TYPE	POLYREX EM
NO. SLOTS	48	NL AMPS AT RATED VOLTAGE	46.6
5 YEAR WARRANTY		WINDING RES @25 C	.0117
MFG. DATE		SER.NO	
			OHMS

Parts List		
Part Number	Description	Quantity
SA249749	SA P44G3982	1.000 EA
RA236609	RA P44G3982	1.000 EA
000613006PU	N/P (RELEASE QTY 10,000) UL CSA LABEL	1.000 EA
NP3237	SS SUPER E INVERTER DUTY IEEE 841	1.000 EA
000613007EX	SS IEEE 841 EMBOSSED AUXILIARY NAMEPLATE	1.000 EA
000692000FF	N/P	1.000 EA
000692000JP	N/P	1.000 EA
000692000VD	LABEL WARNING	1.000 EA
000692000VH	N/P	1.000 EA
004824015A	GREASE POLYREX EM	0.544 LB
032018008CK	HHCS 3/8-16X1L PLATED	4.000 EA
032018020FK	HHCS 3/4-10X2-1/2 PLTD.	4.000 EA
032018028CK	HHCS 3/8-16X3-1/2 PLTD.	3.000 EA
032620016LA	SOCKET SET SCREW-449	3.000 EA
034017014AB	LCKW 3/8 STD. PLATED	4.000 EA
034180014DA	KEY 1/4X1/4X1-3/4 L	1.000 EA
034530072AB	P/NIP 1/8X9"L Threaded both ends	1.000 EA
034530072BB	PIPE NIPPLE,DE - 440-BS	1.000 EA
034600001AA	BUSH 1/4TO1/8 BLACK	1.000 EA
034630002AB	CPLG 1/4" PLATED	1.000 EA
034690005AB	PPLG 3/4 PLATED	2.000 EA
035000001G	GREASE RELIEF FITTING, ALEMITE 317400	1.000 EA
089490097C	BRKT,DE 089490102WCA	1.000 EA
412118006A	DRAIN	1.000 EA

Parts List (continued)		
Part Number	Description	Quantity
089490097C	BRKT,DE 089490102WCA	1.000 EA
412118006A	DRAIN	1.000 EA
083199082RA	G28 SHORT FAN COVER W/BAFFLE ASSEMBLY	1.000 EA
410700004F	WSHR	1.000 EA
415028021E	SEAL	1.000 EA
415072001B	CLAMP	1.000 EA
415096002A	CPLG 1/8 HEX TYPE	1.000 EA
423709011C	WASHER	3.000 EA
702675001D	FAN 250-440	1.000 EA
032018004BK	HHCS 5/16-18X1/2 PLATED	3.000 EA
032018006BK	HHCS 5/16-18X3/4 PLATED	3.000 EA
032018020FK	HHCS 3/4-10X2-1/2 PLTD.	4.000 EA
032018028CK	HHCS 3/8-16X3-1/2 PLTD.	3.000 EA
034017013AB	LCKW 5/16 STD. PLATED	3.000 EA
415915007K	GASK, 26" LAC	1.000 EA
034530072AB	P/NIP 1/8X9"L Threaded both ends	1.000 EA
034530072BB	PIPE NIPPLE,DE - 440-BS	1.000 EA
034600001AA	BUSH 1/4TO1/8 BLACK	1.000 EA
034630002AB	CPLG 1/4" PLATED	1.000 EA
035000001G	GREASE RELIEF FITTING, ALEMITE 317400	1.000 EA
415028021E	SEAL	1.000 EA
415096002A	CPLG 1/8 HEX TYPE	1.000 EA
423709011C	WASHER	3.000 EA
702623022A	G28 AIR DEFLECTOR DRIVE END -- PLASTIC	1.000 EA

Product Information Packet: ECP844252T-4 - 250HP,3570RPM,3PH,60HZ,449TS,A44128M,TEF

702623012A	THERMAL BARRIER, G28	1.000 EA
032018008BK	HHCS 5/16-18X1L PLATED	4.000 EA
032018008DK	HHCS 1/2-13X1 PLATED	4.000 EA
033512004LB	HHTTS 1/4-20X1/2 PLTD.	1.000 EA
035000001A	ALFTG 1/8" 1610-BL	1.000 EA
035000001A	ALFTG 1/8" 1610-BL	1.000 EA
067053014A	GASK 440	1.000 EA
076870000B	+CBCST BLKT - 440	1.000 EA
076871000A	+CBOX CVR BLKT - 449	1.000 EA
406056007A	GASKET, 440	1.000 EA
406099000A	PLUG - FAN COVER 320-440	1.000 EA
415000103D	T/LUG #4AWG-1/0AWG W/HOLE FOR .250 BOLT	1.000 EA
418150003A	GREASE FITTING CAP	1.000 EA
418150003A	GREASE FITTING CAP	1.000 EA
033775004EA	DRSCR #6-1/4 304 S.S.	2.000 EA
034180024HA	KEY 5/8X5/8X3 L	1.000 EA
MG1025N19	WILKO 778.50 BLUE GREEN - 55 GAL DRUMS	0.375 GA
004824003CBY	WILKO PAINT 060.02 - ACTIVATOR	0.094 GA
MG1500G03-5	LACQUER PRIMER, GRAY	0.094 GA
421948051	LABEL, MYLAR	1.000 EA
LB1449	DIV-2/NEC WARNING LABEL	1.000 EA

REL. S.O.	FRAME	HP	TYPE	PHASE/HERTZ	RPM	VOLTS
	449TS	250	P	3/60	3570	460
AMPS	DUTY	AMB °C/ INSUL.	S.F.	NEMA DESIGN	CODE LETTER	ENCL.
266	CONT	40/F	1.15	B	G	TEFC
E/S	ROTOR	TEST S.O.	TEST DATE	SPATOR RES. @25 °C (OHMS BETWEEN LINES)		
833200	418143-3SE	---	---	.0117		

PERFORMANCE

LOAD	HP	AMPERES	RPM	POWER FACTOR %	EFFICIENCY %
NO LOAD	0	46.6	3600	6.30	0
1/4	62.5	88.0	3593	70.3	94.6
2/4	125	142	3585	85.8	96.4
3/4	187	202	3578	89.9	96.6
4/4	250	266	3570	91.2	96.4
5/4	312	334	3561	91.2	96.0
SPEED TORQUE					
	RPM	TORQUE % FULL LOAD	TORQUE LB.-FT.	AMPERES	
LOCKED ROTOR	0	156	575	1767	
PULL UP	1620	139	510	1625	
BREKDOWN	3465	270	991	870	
FULL LOAD	3570	100	367	266	

AMPERES SHOWN FOR 460. VOLT CONNECTION. IF OTHER VOLTAGE CONNECTIONS ARE AVAILABLE, THE AMPERES WILL VARY INVERSELY WITH THE RATED VOLTAGE

REMARKS: TYPICAL DATA  
NEMA NOM. EFF. - 96.2%  
GUAR. MIN. EFF. - 95.8%



DR. BY J.J. HARRISON  
CR. BY W.L. SMITH  
APP. BY W.L. SMITH  
DATE 08/04/10

A-C MOTOR  
PERFORMANCE DATA  
A44WG1505-R001  
ISSUE DATE 03/05/20

A MEMBER OF THE ABB GROUP

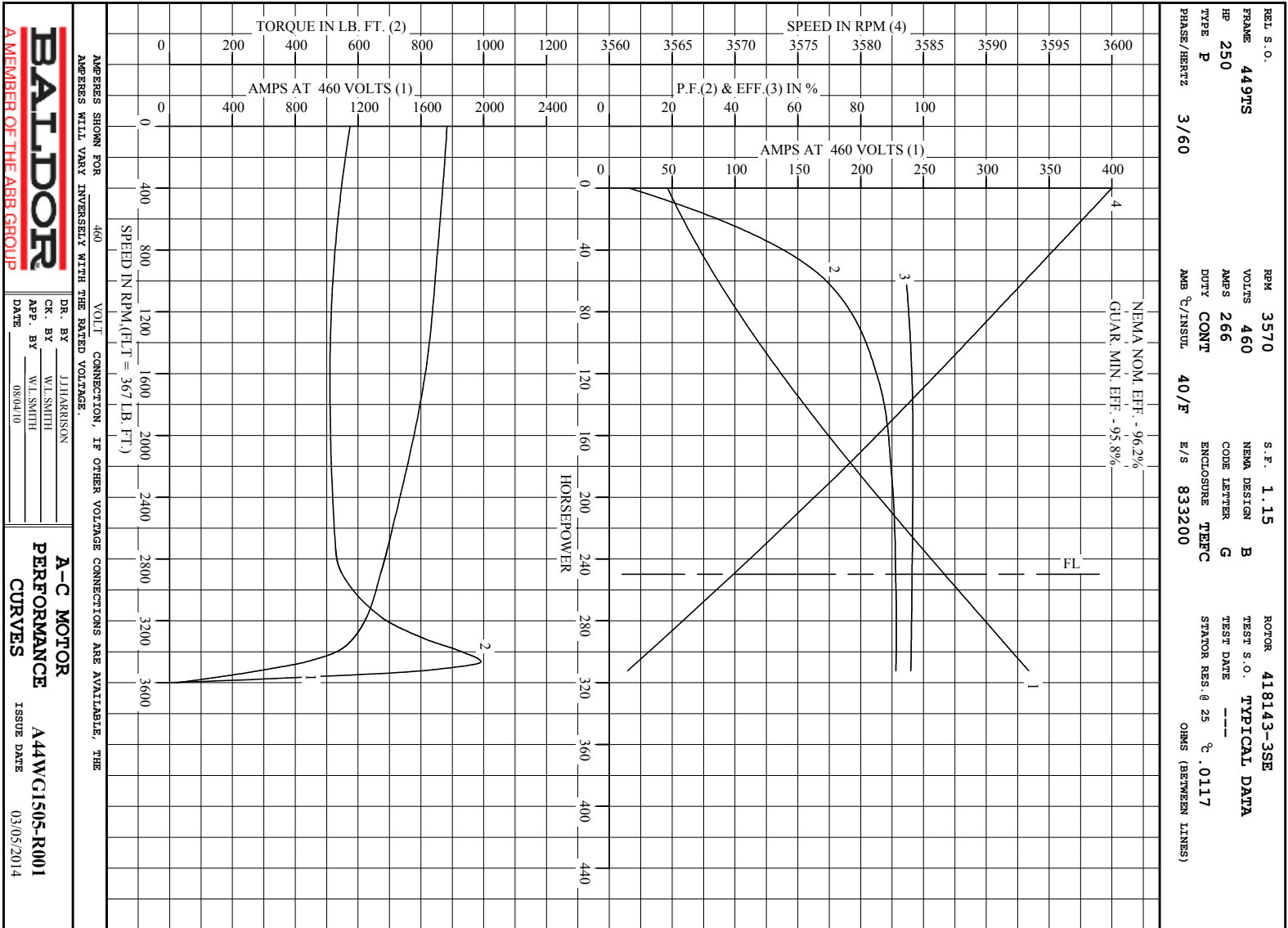

**BALDOR**  
 A MEMBER OF THE ABB GROUP

DR. BY J.HARRISON  
 CK. BY W.L.SMITH  
 App. BY W.L.SMITH  
 DATE 08/04/10

**A-C MOTOR**  
**PERFORMANCE**  
**CURVES**

A44WC1505-R001  
 ISSUE DATE 03/05/2014

Printed on 3/5/14 8:03 @ fagsaun

### DUTY MASTER ALTERNATING CURRENT MOTORS

#### SQUIRREL-CAGE INDUCTION

ENCLOSURE: TOTALLY ENCLOSED

FRAME 449TS ABOVE NEMA RATINGS (3600 RPM MAX)

COOLING: FAN COOLED

MOUNTING: FOOT

INCLUDES 447TS FRAME MOUNTING HOLES

841XL ENCLOSURE ENHANCEMENT

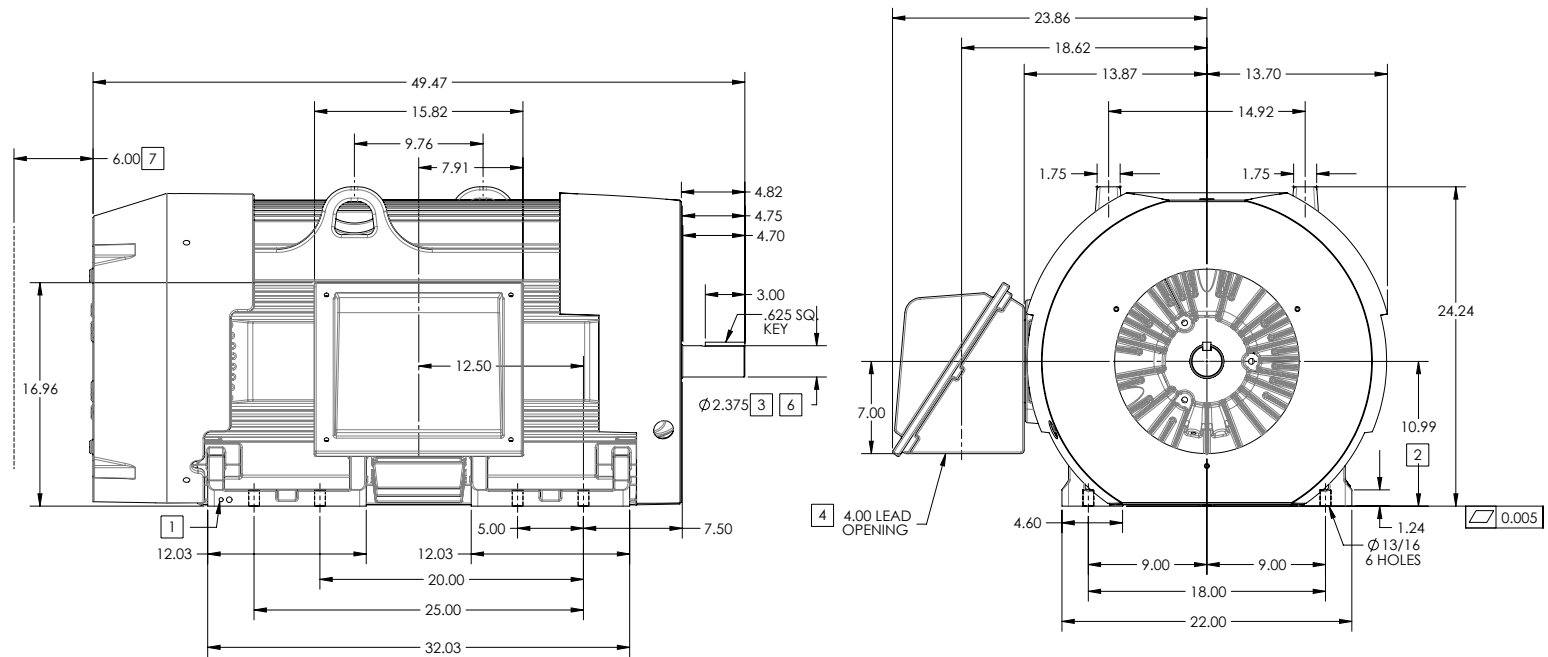

- 1. GROUND HOLES QTY 1 1/2-13 TAP; QTY 1 3/8-16 TAP
- 2. VARIES +.00,-.06
- 3. VARIES +.00,-.001
- 4. ON STANDARD MOTORS THIS IS CONDUIT SIZE. ON XT AND CORROSION PROOF MOTOR THIS IS PIPE TAP.
- 5. MOTOR WEIGHTS MAY VARY BY 15% DEPENDING ON RATING.
- 6. SHAFT TIR = 0.0015IN FOR BALL BEARING MOTORS AND 0.002 IN FOR ROLLER BEARING CONSTRUCTION
- 7. OBSTRUCTION MUST NOT ENCR OACH ON AIR INLET

**[5] WEIGHT (LBS): 3045**

DRIVE END AIR DEFLECTOR IS ONLY INCLUDED WHEN NECESSARY.

DIMENSIONS ARE IN INCHES; SEE SHEET 2 FOR DIMENSIONS IN MILLIMETERS

CUSTOMER IS RESPONSIBLE FOR DETERMINING THAT MOTOR PERFORMANCE IS SUITABLE IN THE APPLICATION.

CONDUIT BOX LOCATED ON OPPOSITE SIDE WHEN F-2. IF MOUNTING CLEARANCE DETAILS ARE REQUIRED, CONSULT FACTORY. MAXIMUM PERMISSIBLE SHAFT RUNOUT WHEN MEASURED AT END OF STANDARD SHAFT EXTENSION IS .003" T.I.R. TO 5 INCH DIA.

SHEET NUMBER  
**1 OF 2**

990-1727-119

REV. DESC: UPDATE SHAFT TO 609180062RA TO MATCH BOMS	BY: RAGSSI
REV: B	VERSION: 02
MODEL NO. 617427-066	REVISED: 09-28-17 08:20/2015
TDR: 00000936970	

**BALDOR**

G449TS-447TS STD - FOOTED - SIDE-CENTER CB - 841XL

**DUTY MASTER ALTERNATING CURRENT MOTORS**  
SQUIRREL-CAGE INDUCTION

ENCLOSURE: TOTALLY ENCLOSED

FRAME 449TS ABOVE NEMA RATINGS (3600 RPM MAX)

COOLING: FAN COOLED

MOUNTING: FOOT

INCLUDES 447TS FRAME MOUNTING HOLES

841XL ENCLOSURE ENHANCEMENT

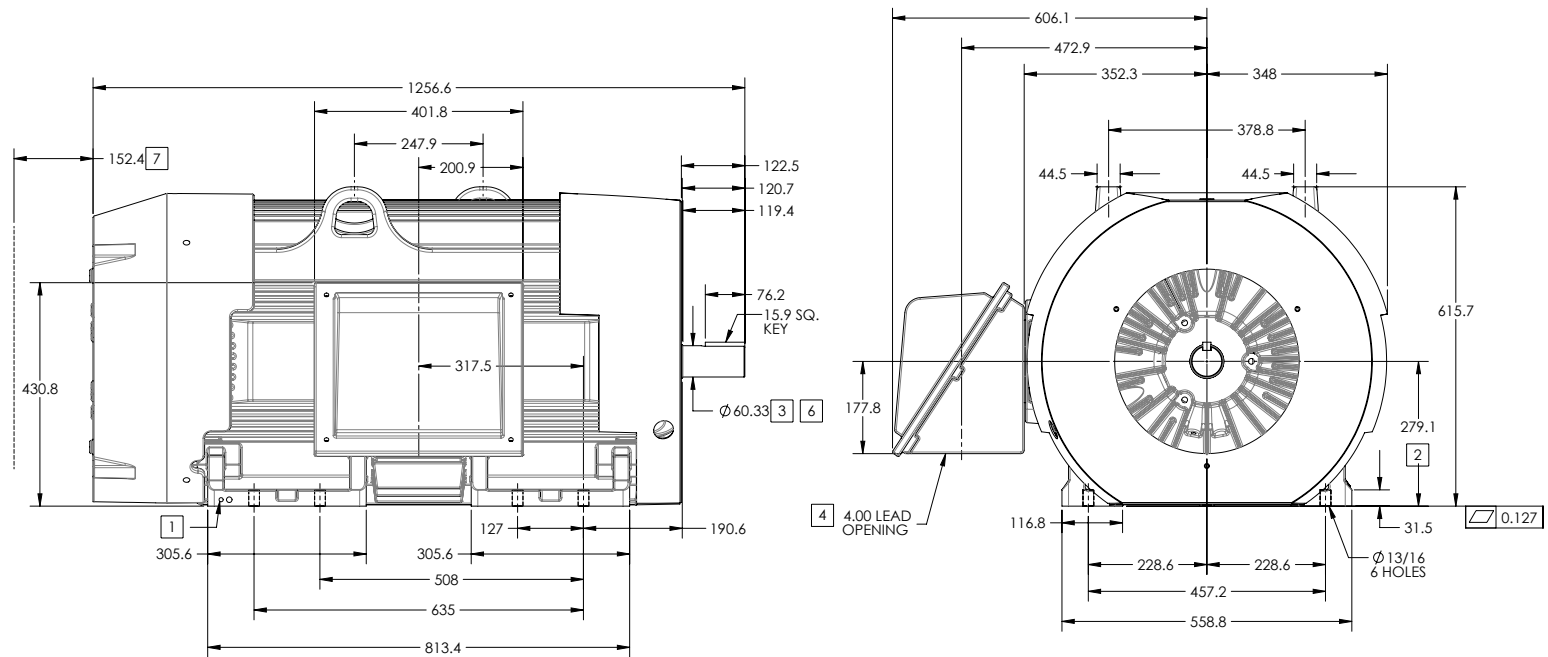

- 1. GROUND HOLES QTY 1 1/2-13 TAP; QTY 1 3/8-16 TAP
- 2. VARIES +.00,-.06
- 3. VARIES +.00,-.001
- 4. ON STANDARD MOTORS THIS IS CONDUIT SIZE. ON XT AND CORROSION PROOF MOTOR THIS IS PIPE TAP.
- 5. MOTOR WEIGHTS MAY VARY BY 15% DEPENDING ON RATING.
- 6. SHAFT TIR = 0.038MM FOR BALL BEARING MOTORS AND 0.051 FOR ROLLER BEARING CONSTRUCTION
- 7. OBSTRUCTION MUST NOT ENCROACH ON AIR INLET

**[5] WEIGHT (LBS): 1380**

DRIVE END AIR DEFLECTOR IS ONLY INCLUDED WHEN NECESSARY.

DIMENSIONS ARE IN MILLIMETERS; SEE SHEET 1 FOR DIMENSIONS IN INCHES

CUSTOMER IS RESPONSIBLE FOR DETERMINING THAT MOTOR PERFORMANCE IS SUITABLE IN THE APPLICATION.

CONDUIT BOX LOCATED ON OPPOSITE SIDE WHEN F-2. IF MOUNTING CLEARANCE DETAILS ARE REQUIRED, CONSULT FACTORY. MAXIMUM PERMISSIBLE SHAFT RUNOUT WHEN MEASURED AT END OF STANDARD SHAFT EXTENSION IS .08 MM T.I.R. TO 127 MM DIA.

SHEET NUMBER  
**2 OF 2**

9907-272719

REV. DESC: UPDATE SHAFT TO 609180062RA TO MATCH BOMS	MODEL NO. 617427-066	BY: RAGSSI
REV: B	VERSION: 02	REVISED: 09-28-17 08:20/2015
TDR: 00000936970		

**BALDOR**

G449TS-447TS STD - FOOTED - SIDE-CENTER C/B - 841XL

416820-036

A-C MOTOR  
CONNECTION DIAGRAM  
STANDARD 3 LEAD CONNECTED

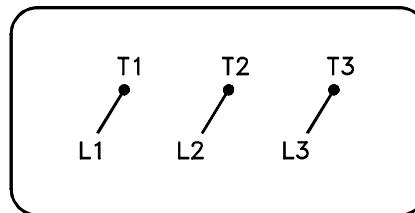

(N.P. 1575-BA)

416820-036

REV. DESC: LOADED TO BUS, C/R 335225		
REV. LTR: -	VERSION: 00	TDR: 000000538207
FILE: \MGA\00000\682	REVISED: 11:54:06 04/30/2010	
MTL: -	BY: RAGRA	

**BALDOR**

CONN DIAG - STANDARD 3 LEAD

SH 1 of 1

Marketing maintained PDF of MN408:

<http://www.baldor.com/support/Literature/Load.ashx/MN408?ManNumber=MN408>

Marketing maintained PDF of MN416:

<http://www.baldor.com/support/Literature/Load.ashx/MN416?ManNumber=MN416>