

BALDOR® • **RELIANCE**

Product Information Packet

EGDM3774T

10HP,1760RPM,3PH,60HZ,215TZ,0748M,TEFC,F

Part Detail							
Revision:	-	Status:	PRD/A	Change #:		Proprietary:	No
Type:	AC	Prod. Type:	0748M	Elec. Spec:	07WGX776	CD Diagram:	CD0005
Enclosure:	TEFC	Mfg Plant:		Mech. Spec:	07N230	Layout:	07LYN230
Frame:	215TZ	Mounting:	F1	Poles:	04	Created Date:	01-08-2016
Base:	RG	Rotation:	R	Insulation:	F	Eff. Date:	01-13-2016
Leads:	9#14 72" LONG Y					Replaced By:	
Literature:		Elec. Diagram:					

Nameplate NP3126L										
CAT.NO.	EGDM3774T									
SPEC.	07N230X776G1									
HP	10									
VOLTS	208-230/460									
AMP	26.3-25/12.5									
RPM	1760									
FRAME	215TZ				HZ	60			PH	3
SER.F.	1.15		CODE	H	DES	A		CL	F	
NEMA-NOM-EFF	92.4		PF	82						
RATING	40C AMB-CONT									
CC	010A				USABLE AT 208V			26.3		
DE	6307				ODE	6206				
ENCL	TEFC			SN						

Parts List		
Part Number	Description	Quantity
SA313213	SA 07N230X776G1	1.000 EA
RA300664	RA 07N230X776G1	1.000 EA
37FN3002C01	EXFN, PLASTIC, 6.00 OD, 1.155 ID	1.000 EA
HW3201A05	3/8-16 EYEBOLT	1.000 EA
09CB3001	CB W/1.09 LEAD HOLE FOR 37, 39, 307 & 30	1.000 EA
09GS1000	GASKET-CONDUIT BOX, 1/16 THICK LEXIDE	1.000 EA
51XW2520A12	.25-20 X .75, TAPTITE II, HEX WSHR SLTD	2.000 EA
11XW1032G06	10-32 X .38, TAPTITE II, HEX WSHR SLTD U	1.000 EA
HW3001B01	BRASS CUP WASHER, FOR #8 SCREW	1.000 EA
37EP1100B65	FRONT TEFC 206 BRG 37M W/O GRSSR FOR 37FH	1.000 EA
HW5100A06	W2420-025 WVY WSHR (WB)	1.000 EA
37EP1101D14	PU ENDPLATE MACH, SEAL, DRAIN	1.000 EA
HW4600B51	SEAL 1.375 X 2.125 X 0.313 SINGLE LIP DB	1.000 EA
HA3104A32	THRUBOLT- 5/16-18 X12.750	4.000 EA
XY3118A12	5/16-18 HEX NUT DIRECTIONAL SERRATION	4.000 EA
51XB1214A20	12-14X1.25 HXWSSLD SERTYB	1.000 EA
07FH4007A07	IEC FH NO GRSSR, NOTCH @ 6:00 & 3 F/C HOL	1.000 EA
51XW1032A06	10-32 X .38, TAPTITE II, HEX WSHR SLTD S	3.000 EA
09CB3501	CONDUIT BOX LID FOR 09CB3001 & 09CB3002	1.000 EA
09GS1013	09 GS FOR 09CB3501 LID - LEXIDE	1.000 EA
51XW2520A12	.25-20 X .75, TAPTITE II, HEX WSHR SLTD	2.000 EA
HA1005A02	SLINGER, OD 2.00, ID 1.14, 206 BRG,	1.000 EA
HW4600B33	V-RING SLINGER 1.375 X 1.890 X .35 VITON	1.000 EA
HW2501F22	KEY, 5/16 SQ X 2.500	1.000 EA

Parts List (continued)		
Part Number	Description	Quantity
HA7000A02	KEY RETAINER RING, 1 1/8 DIA, 1 3/8 DIA	1.000 EA
85XU0407S04	4X1/4 U DRIVE PIN STAINLESS	2.000 EA
LB1115N	LABEL,LIFTING DEVICE (ON ROLLS)	1.000 EA
MJ5001A27	32220KN GRAY SEALER *MIN BUY 4 QTS=1GAL	0.001 QT
MJ1000A02	GREASE, POLYREX EM EXXON (USe 4824-15A)	0.050 LB
MG1025C02	WILKOFASG SG, 787.105, TAN	0.036 GA
LC0005E01	CONN.DIA./WARNING LABEL (LC0005/LB1119N)	1.000 EA
MN416A01	TAG-INSTAL-MAINT no wire (1000/bx) 11/14	1.000 EA
NP3126L	ALUM FARM DUTY SUPER-E UL CSA-EEV PREM	1.000 EA
07PA1011	PKG GRP, 07 CAST IRON PK1181	1.000 EA
10XL3808A28	3/8 X 1 3/4" LAG SCREW	2.000 EA

AC Induction Motor Performance Data

Record # 27907 - Typical performance - not guaranteed values

Winding: 07WGX776-R006	Type: 0748M	Enclosure: TEFC
-------------------------------	--------------------	------------------------

Nameplate Data				460 V, 60 Hz: High Voltage Connection	
Rated Output (HP)	10			Full Load Torque	29.8 LB-FT
Volts	208-230/460			Start Configuration	direct on line
Full Load Amps	26.3-25/12.5			Breakdown Torque	87 LB-FT
R.P.M.	1760			Pull-up Torque	51.9 LB-FT
Hz	60	Phase	3	Locked-rotor Torque	57.5 LB-FT
NEMA Design Code	A	KVA Code	H	Starting Current	88.5 A
Service Factor (S.F.)	1.15			No-load Current	5.12 A
NEMA Nom. Eff.	92.4	Power Factor	82	Line-line Res. @ 25°C	0.973 Ω
Rating - Duty	40C AMB-CONT			Temp. Rise @ Rated Load	60°C
S.F. Amps				Temp. Rise @ S.F. Load	76°C
				Locked-rotor Power Factor	35
				Rotor inertia	1.18 LB-FT ²

Load Characteristics 460 V, 60 Hz, 10 HP

% of Rated Load	25	50	75	100	125	150	S.F.
Power Factor	44	67	78	82	84	85	83
Efficiency	90	92.9	93.1	92.5	91.4	90.1	91.8
Speed	1790	1781	1771	1762	1750	1739	1755
Line amperes	5.84	7.52	9.75	12.3	15.2	18.3	14

Performance Graph at 460V, 60Hz, 10.0HP Typical performance - Not guaranteed values

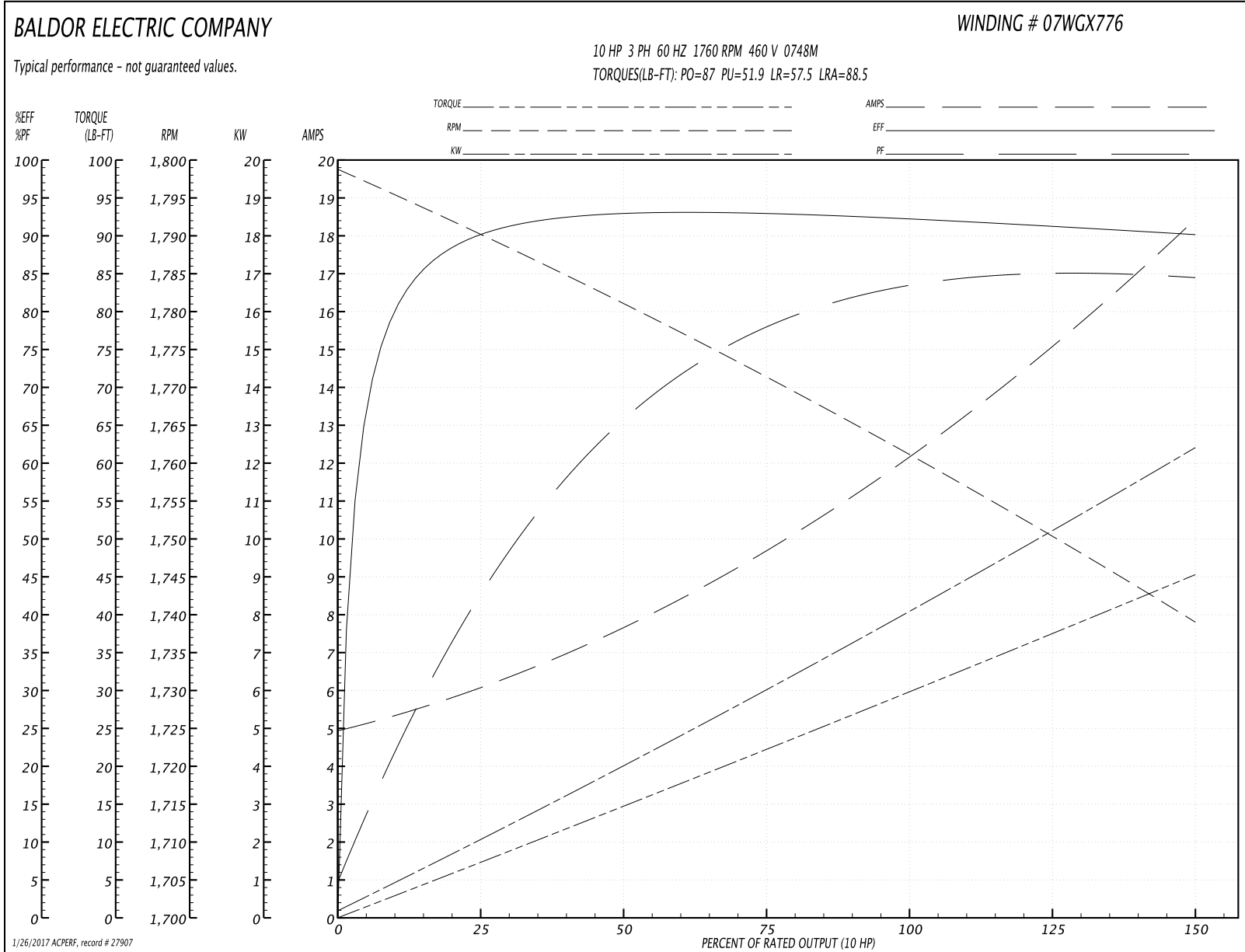

07LYN230

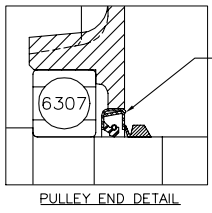
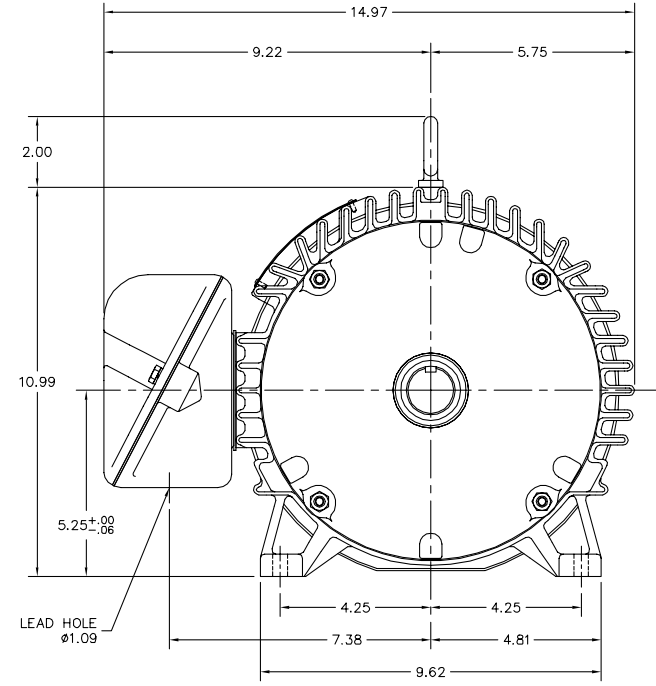
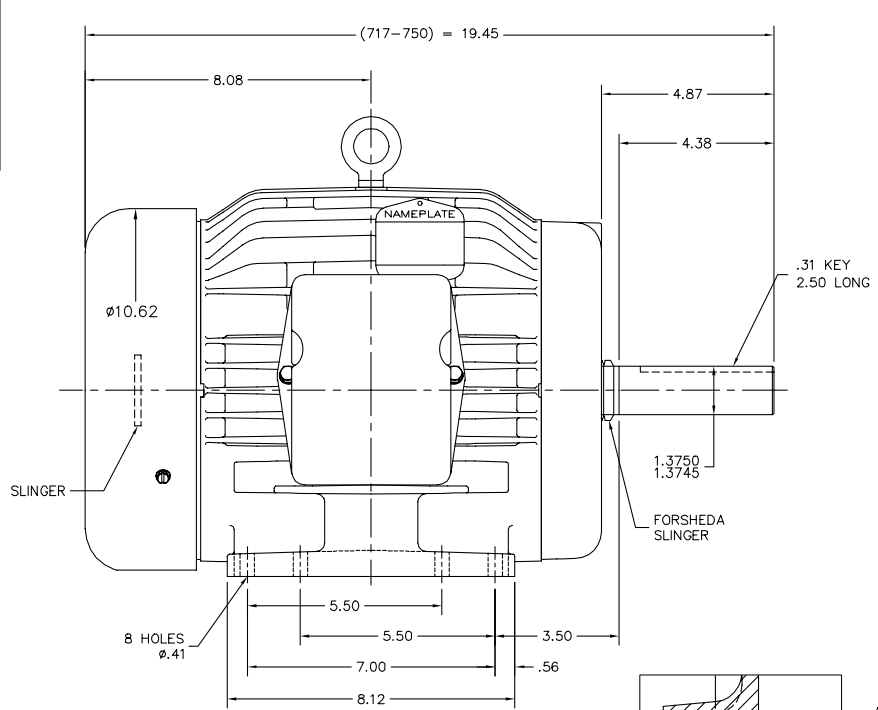

APPLY COAT OF SEALER TO HOUSING BEFORE PRESSING IN SEAL

CUSTOMER IS RESPONSIBLE FOR DETERMINING THAT BALDOR'S PRODUCT WILL PERFORM SUITABLY IN THE INTENDED APPLICATION.

REV. DESC: NEW	VERSION: 00	TDR: 000000894905
REV. LTR: -	REVISED: 03:01:11 03/09/2015	BY: ENALIFO
FILE: \AAA\00216\095		
MTL: -		

BALDOR

HOR 213-5TZ TEFC 307M, FARM DUTY, V=4.38, SEAL

SH 1 of 1

07LYN230

CD0005



LOW VOLTAGE
(2Y)



LINE

HIGH VOLTAGE
(1Y)



LINE

NOTES:

1. INTERCHANGE ANY TWO LINE LEADS TO REVERSE ROTATION.
2. OPTIONAL THERMOSTATS ARE PROVIDED WHEN SPECIFIED.
3. ACTUAL NUMBER OF INTERNAL PARALLEL CIRCUITS MAY BE A MULTIPLE OF THOSE SHOWN ABOVE.
4. LEAD COLORS ARE OPTIONAL. LEADS MUST ALWAYS BE NUMBERED AS SHOWN.

REV. DESC: REVISE TO SHOW OPTIONAL COLORS			
REV. LTR: E	BY: JLP	REVISED: 01/19/99 10:15	TDR: 0171435
90000		FILE: AAA00005140	MDL: -
		MTL: -	

BALDOR ELECTRIC Co.

3PH, DV, 9 LEADS

CD0005