

# **BALDOR® • RELIANCE**

## **Product Information Packet**

### **EM7174T-I**

**10//7.5HP,3490//2900RPM,3PH,60//50HZ,215**

Part Detail							
Revision:	R	Status:	PRD/A	Change #:		Proprietary:	No
Type:	AC	Prod. Type:	0730M	Elec. Spec:	07WGY855	CD Diagram:	CD0005
Enclosure:	XPFC	Mfg Plant:		Mech. Spec:	07J231	Layout:	07LYJ231
Frame:	215T	Mounting:	F1	Poles:	02	Created Date:	01-13-2012
Base:	RG	Rotation:	R	Insulation:	F	Eff. Date:	04-18-2016
Leads:	9#14					Replaced By:	
Literature:		Elec. Diagram:					

Nameplate NP0977XPSLEV											
NO.							CC	010A			
SER.							TEMP CODE	T3C			
SPEC.	07J231Y855G1										
CAT.NO.	EM7174T-I										
HP	10//7.5										
VOLTS	230/460//190/380										
AMPS	23.6/11.8//21.6/11										
RPM	3490//2900						MOTOR WEIGHT	212			
HERTZ	60//50			PH	3	CL	F	DE BRG	6307		
SER.F.	1.15			DES	B	CODE	G	ODE BRG	6206		
FRAME	215T			GREASE	POLYREX EM						
RATING	40C AMB-CONT 55C AMB AT 1.0 SF										
USABLE AT 208V							NEMA-NOM-EFF	90.2		PF	87
	NEMA MG-1 PT 5,IP55										

Parts List		
Part Number	Description	Quantity
SA237163	SA 07J231Y855G1	1.000 EA
RA224098	RA 07J231Y855G1	1.000 EA
36FN3000C02	EXFN, PLASTIC, 5.25 OD, 1.175 ID	1.000 EA
HA3210E08	.250X 7/8 PIN 312-57	1.000 EA
HW3201A05	3/8-16 EYEBOLT	1.000 EA
07CB1000A01	CONDUIT BOX MACH	1.000 EA
10XN3118A16	5/16-18X1 HEX HD CAP	4.000 EA
WD1000B17	T&B CX35TN TERMINAL	1.000 EA
11XW1032G06	10-32 X .38, TAPTITE II, HEX WSHR SLTD U	1.000 EA
07EP1707A17	FREP XP GR C W/DRAINS, GRSRS	1.000 EA
HW4500A19	1/4-28X1/4 SLOTTED PLUG F/S	2.000 EA
HW4506A02	BREATHER/DRAIN-EXP PROOF-.125-27 NPTF AI	1.000 EA
HW3022E05	.125 DIA X .500 ROLLED SPRING PIN	1.000 EA
10XN3816K28	3/8-16 X 1.75 HEX HD CAP SCREW, GRADE 5	4.000 EA
HW1001A38	LOCKWASHER 3/8, ZINC PLT .688 OD, .382 I	4.000 EA
HW5100A06	W2420-025 WVY WSHR (WB)	1.000 EA
07EP1709A17	SPL PU ENDPLATE X-P W/DRAIN/LOCKED BEARI	1.000 EA
HW4500A19	1/4-28X1/4 SLOTTED PLUG F/S	2.000 EA
HW4506A02	BREATHER/DRAIN-EXP PROOF-.125-27 NPTF AI	1.000 EA
HW3022E05	.125 DIA X .500 ROLLED SPRING PIN	1.000 EA
10XN3816K28	3/8-16 X 1.75 HEX HD CAP SCREW, GRADE 5	4.000 EA
HW1001A38	LOCKWASHER 3/8, ZINC PLT .688 OD, .382 I	4.000 EA
10XN2520A36	1/4-20X 2 1/4 HEX HD X	4.000 EA
HW1001A25	LOCKWASHER 1/4, ZINC PLT .493 OD, .255 I	4.000 EA

<b>Parts List (continued)</b>		
<b>Part Number</b>	<b>Description</b>	<b>Quantity</b>
HA2065A02	SLINGER, ALUM MODLE 36 & 37 DRILL RIG MT	1.000 EA
07FH1003A01	STANDARD 307 EXPLOSION PROOF FAN HOUSING	1.000 EA
10XN2520A12	O1/4-20X 3/4 HEX HEAD CAP	4.000 EA
07CB1502A01	CONDUIT BOX LID MACH (DUCTILE IRON)	1.000 EA
84XN2520J16	1/4-20 X 1 SOC HD CAP SCREW	4.000 EA
HW1001A25	LOCKWASHER 1/4, ZINC PLT .493 OD, .255 I	4.000 EA
80XN1032A07	SET SCREW, HEX XOCK, ZN	1.000 EA
HW2501F21	KEY, 5/16 SQ X 2.375	1.000 EA
HA7000A02	KEY RETAINER RING, 1 1/8 DIA, 1 3/8 DIA	1.000 EA
85XU0407S04	4X1/4 U DRIVE PIN STAINLESS	6.000 EA
LB1081F	ALUM XP CAUTION LABEL (FS PLANT ONLY-	1.000 EA
LB1115N	LABEL,LIFTING DEVICE (ON ROLLS)	1.000 EA
MJ1000A02	GREASE, POLYREX EM EXXON (USe 4824-15A)	0.050 LB
51XB1214A20	12-14X1.25 HXWSSLD SERTYB	1.000 EA
MG1025G29	WILKOFASST, 789.229, DARK CHARCOAL GRAY	0.036 GA
LB1119N	WARNING LABEL	1.000 EA
LC0145B01	CONNECTION LABEL	1.000 EA
MN416A01	TAG-INSTAL-MAINT no wire (1000/bx) 11/14	1.000 EA
NP0977XPSLEV	SS XP UL CSA-EEV CC CL-I GP-C&D	1.000 EA
07PA1011	PKG GRP, 07 CAST IRON PK1181	1.000 EA
10XL3808A28	3/8 X 1 3/4" LAG SCREW	2.000 EA

**AC Induction Motor Performance Data**

Record # 36757 - Typical performance - not guaranteed values

<b>Winding:</b> 07WGY855-R003	<b>Type:</b> 0730M	<b>Enclosure:</b> XPFC
-------------------------------	--------------------	------------------------

Nameplate Data				460 V, 60 Hz: High Voltage Connection	
Rated Output (HP)	10//7.5			Full Load Torque	15.1 LB-FT
Volts	230/460//190/380			Start Configuration	direct on line
Full Load Amps	23.6/11.8//21.6/10.8			Breakdown Torque	56.3 LB-FT
R.P.M.	3490//2900			Pull-up Torque	17.7 LB-FT
Hz	60//50	Phase	3	Locked-rotor Torque	23.8 LB-FT
NEMA Design Code	B	KVA Code	G	Starting Current	78.5 A
Service Factor (S.F.)	1.15			No-load Current	3.65 A
NEMA Nom. Eff.	90.2	Power Factor	87	Line-line Res. @ 25°C	1.05 Ω
Rating - Duty	40C AMB-CONT			Temp. Rise @ Rated Load	63°C
S.F. Amps				Temp. Rise @ S.F. Load	79°C
				Locked-rotor Power Factor	33.7
				Rotor inertia	0.273 LB-FT <sup>2</sup>

Load Characteristics 460 V, 60 Hz, 10 HP

% of Rated Load	25	50	75	100	125	150	S.F.
Power Factor	60	80	87	90	90	90	90
Efficiency	88.1	91.5	91.3	90.5	89.6	88.2	90.1
Speed	3576	3551	3525	3497	3465	3429	3476
Line amperes	4.55	6.56	8.97	11.6	14.5	17.7	13.4

Performance Graph at 460V, 60Hz, 10.0HP Typical performance - Not guaranteed values

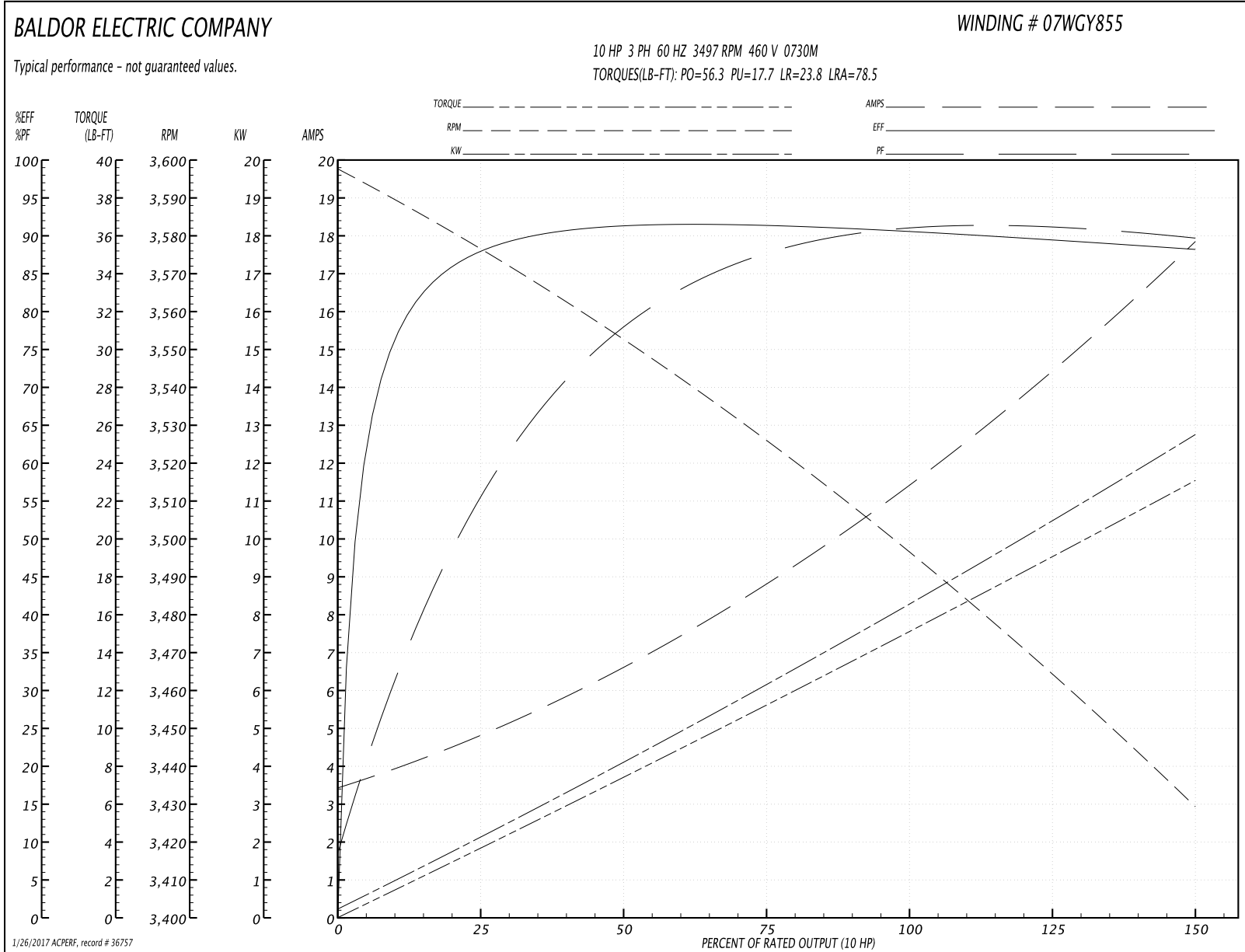

07LYJ231

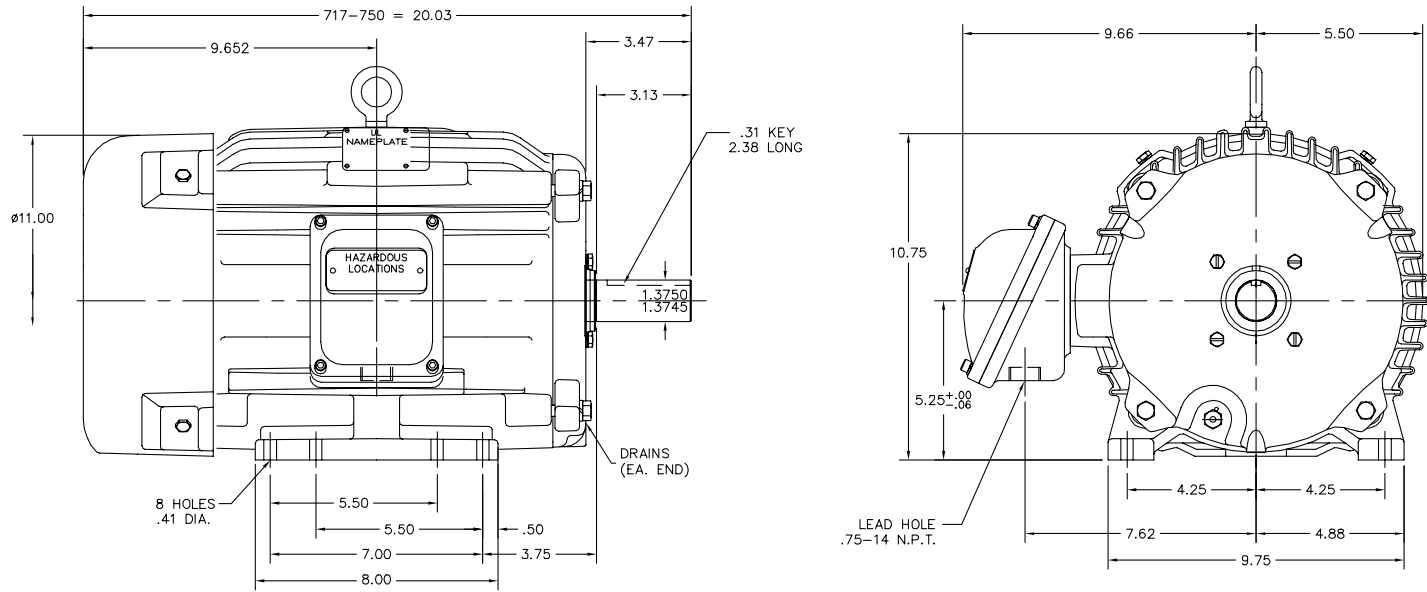

07LYJ231

CUSTOMER IS RESPONSIBLE FOR DETERMINING THAT BALDOR'S PRODUCT WILL PERFORM SUITABLY IN THE INTENDED APPLICATION.

REV. DESC: ADD DRAIN LEADER TO LAYOUT			TDR: 000000934411
REV. LTR: D	VERSION: 02		
FILE: \AAA\00076\166	REVISED: 11:03:16 07/14/2015	BY: ENALEMO	
MTL: -	☐		

**BALDOR**

HDRZ 213-5T XPFC X307M CL I-GP C&D - DRILL RIG MOTOR  
SH 1 of 1

CD0005



LOW VOLTAGE  
(2Y)

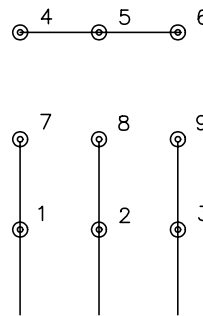

LINE

HIGH VOLTAGE  
(1Y)

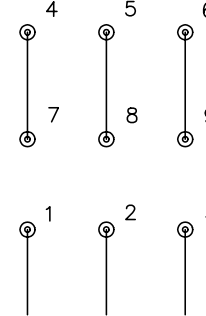

LINE

NOTES:

1. INTERCHANGE ANY TWO LINE LEADS TO REVERSE ROTATION.
2. OPTIONAL THERMOSTATS ARE PROVIDED WHEN SPECIFIED.
3. ACTUAL NUMBER OF INTERNAL PARALLEL CIRCUITS MAY BE A MULTIPLE OF THOSE SHOWN ABOVE.
4. LEAD COLORS ARE OPTIONAL. LEADS MUST ALWAYS BE NUMBERED AS SHOWN.

REV. DESC: REVISE TO SHOW OPTIONAL COLORS			
REV. LTR: E	BY: JLP	REVISED: 01/19/99 10:15	TDR: 0171435
9000D		FILE: AAA00005140	MDL: -
		MTL: -	

**BALDOR ELECTRIC Co.**

3PH, DV, 9 LEADS

CD0005