

BALDOR® • ***RELIANCE***

Product Information Packet

VNEDM3554

1.5HP,1755RPM,3PH,60HZ,56C,3533M,TENV,F1

Part Detail							
Revision:	C	Status:	PRD/A	Change #:		Proprietary:	No
Type:	AC	Prod. Type:	3533M	Elec. Spec:	35WGM613	CD Diagram:	CD0005
Enclosure:	TENV	Mfg Plant:		Mech. Spec:	35E4329	Layout:	35LYE4329
Frame:	56C	Mounting:	F1	Poles:	04	Created Date:	04-21-2016
Base:	N	Rotation:	R	Insulation:	F	Eff. Date:	10-20-2016
Leads:	9#18					Replaced By:	
Literature:		Elec. Diagram:					

Parts List		
Part Number	Description	Quantity
SA319777	SA 35E4329M613G1	1.000 EA
RA307485	RA 35E4329M613G1	1.000 EA
NS2512A01	INSULATOR, CONDUIT BOX X	1.000 EA
35CB1001A01E	SPL CONDUIT BOX, MACHINED (E-COAT)	1.000 EA
35GS1022A02	GASKET BOX .06 THK NEOP BLK HDN 30-40 DU	1.000 EA
51XB1016A08	10-16X 1/2HXWSSLD SERTYB	2.000 EA
11XW1032G06	10-32 X .38, TAPTITE II, HEX WSHR SLTD U	1.000 EA
HW3001B01	BRASS CUP WASHER, FOR #8 SCREW	1.000 EA
35EP1100B94E	FREP TENV (4).125 NPT DRAINS	1.000 EA
HA4054	SHORT T-DRAIN FITTING, .125" N.P.T.	1.000 EA
HW4500A33	1/8 NPT STAINLESS,HOLO-KROME #13002,PRES	3.000 EA
HW5100A03SP	WAVY WASHER (W1543-017)	1.000 EA
35EP1300A113E	PUEP ENCL 205 BRG F/SEAL, (4).125 NPT	1.000 EA
HA4054	SHORT T-DRAIN FITTING, .125" N.P.T.	1.000 EA
HW4606A02	JM CLIPPER/SEAL (LWE-0938-1624-AL23)	1.000 EA
HW4500A33	1/8 NPT STAINLESS,HOLO-KROME #13002,PRES	3.000 EA
12XN1032S20	10-32 X 1-1/4 HEX M.S. , STAINLESS STEEL	2.000 EA
35CB4516E	CONDUIT BOX LID, E-COAT	1.000 EA
36GS1002	GASKET, 1/16" NEOPRENE CONDUIT BOX LID	1.000 EA
59XW0832S07	TAPTITE II,HEX WSHR UNSLTD SER,410 S.S.,	4.000 EA
HW2502D13	SS KEY, 3/16 SQ X 1.375	1.000 EA
HA7000A04	KEY RETAINER 0.625 DIA SHAFTS	1.000 EA
MJ5001A02	732 CL SEALANT 3 OZ DIXIE BEARING 289100	0.001 EA
85XU0407S04	4X1/4 U DRIVE PIN STAINLESS	2.000 EA

Parts List (continued)		
Part Number	Description	Quantity
LB1164	LABEL,WARNING AND DRAIN	1.000 EA
MJ5001A23	P.D. GEORGE B-276 AIR DRY VARNISH	0.001 GA
LB1000	LABEL, DIRTY DUTY	1.000 EA
WD1000D21	TRM,T&B #B71M,RING,18-14,.25,NON-INSL	9.000 EA
MJ1000A02	GREASE, POLYREX EM EXXON (USe 4824-15A)	0.050 LB
MG1500Y02	PRIMER,347.29+347.29C ACTIVATOR WILKOPON	0.010 GA
MG1025L01	WILKOFASST FD, 786.04, BLACK	0.010 GA
HA3100S09	THRUBOLT 9.25 LENGTH SS	4.000 EA
LC0005	CONN.DIA.,TY M,9-LD,DUAL VOLT,REVERSING	1.000 EA
NP3504E	SS DIRTY DUTY PLUS INV UL CSA-C US EEV	1.000 EA
36PA1000	PKG GRP, PRINT PK1016A06	1.000 EA
PK3082	STYROFOAM CRADLE	1.000 EA
MN416A01	TAG-INSTAL-MAINT no wire (1200/bx) 11/14	1.000 EA

AC Induction Motor Performance Data

Record # 56528 - Typical performance - not guaranteed values

Winding: 35WGM613-R025	Type: 3533M	Enclosure: TENV
-------------------------------	--------------------	------------------------

Nameplate Data				460 V, 60 Hz: High Voltage Connection	
Rated Output (HP)	1.5			Full Load Torque	4.45 LB-FT
Volts	230/460			Start Configuration	direct on line
Full Load Amps	4.2/2.1			Breakdown Torque	20.8 LB-FT
R.P.M.	1755			Pull-up Torque	11.7 LB-FT
Hz	60	Phase	3	Locked-rotor Torque	14.6 LB-FT
NEMA Design Code	B	KVA Code	K	Starting Current	20 A
Service Factor (S.F.)	1.15			No-load Current	1.17 A
NEMA Nom. Eff.	86.5	Power Factor	76	Line-line Res. @ 25°C	8 Ω
Rating - Duty	40C AMB-CONT			Temp. Rise @ Rated Load	77°C
S.F. Amps				Temp. Rise @ S.F. Load	92°C
				Locked-rotor Power Factor	46
				Rotor inertia	0.195 LB-FT ²

Load Characteristics 460 V, 60 Hz, 1.5 HP

% of Rated Load	25	50	75	100	125	150	S.F.
Power Factor	35	54	68	76	81	84	79
Efficiency	80.5	87.1	88.3	88.8	88.3	87.4	88.5
Speed	1791	1782	1773	1764	1753	1743	1757
Line amperes	1.26	1.46	1.76	2.07	2.45	2.87	2.3

Performance Graph at 460V, 60Hz, 1.5HP Typical performance - Not guaranteed values

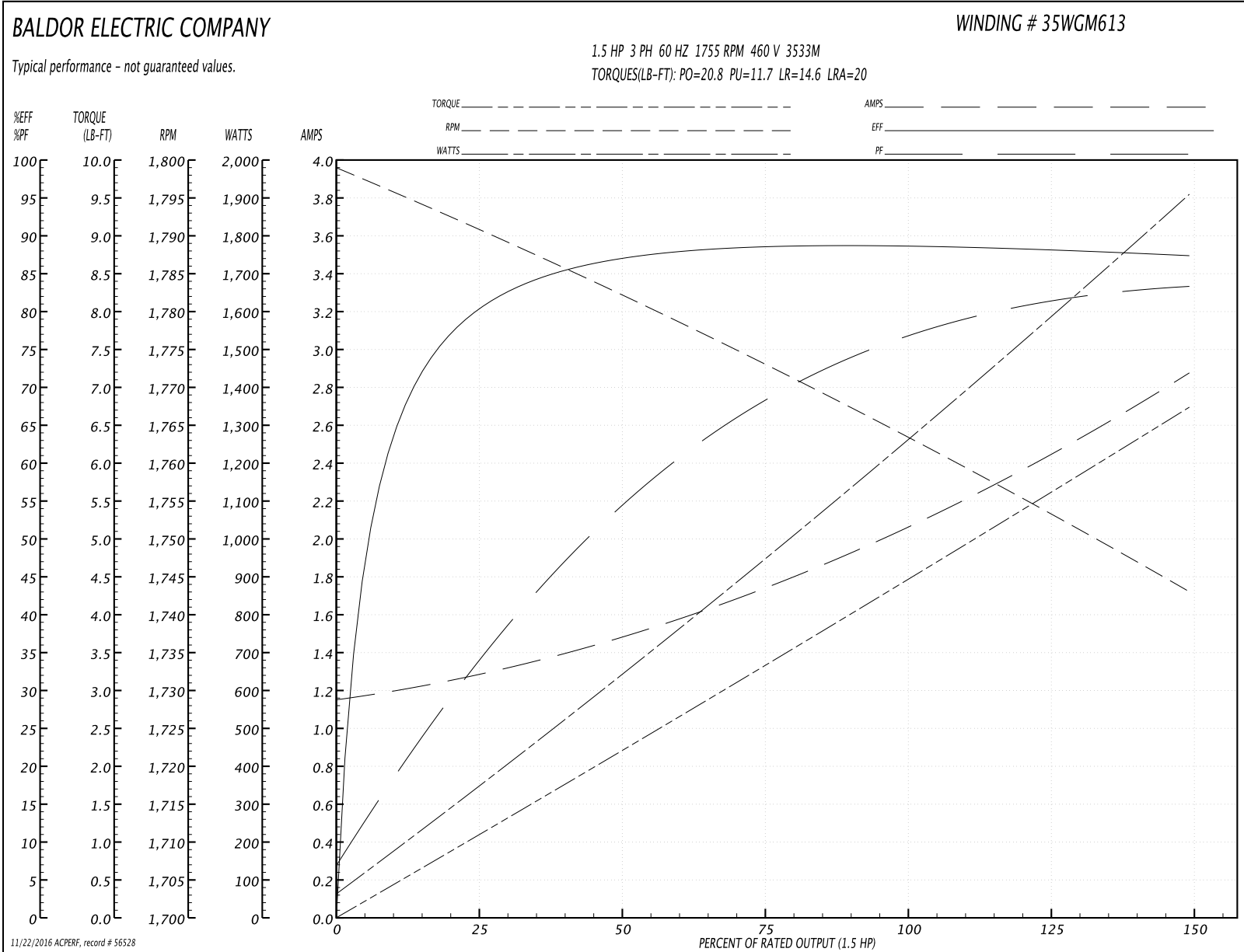

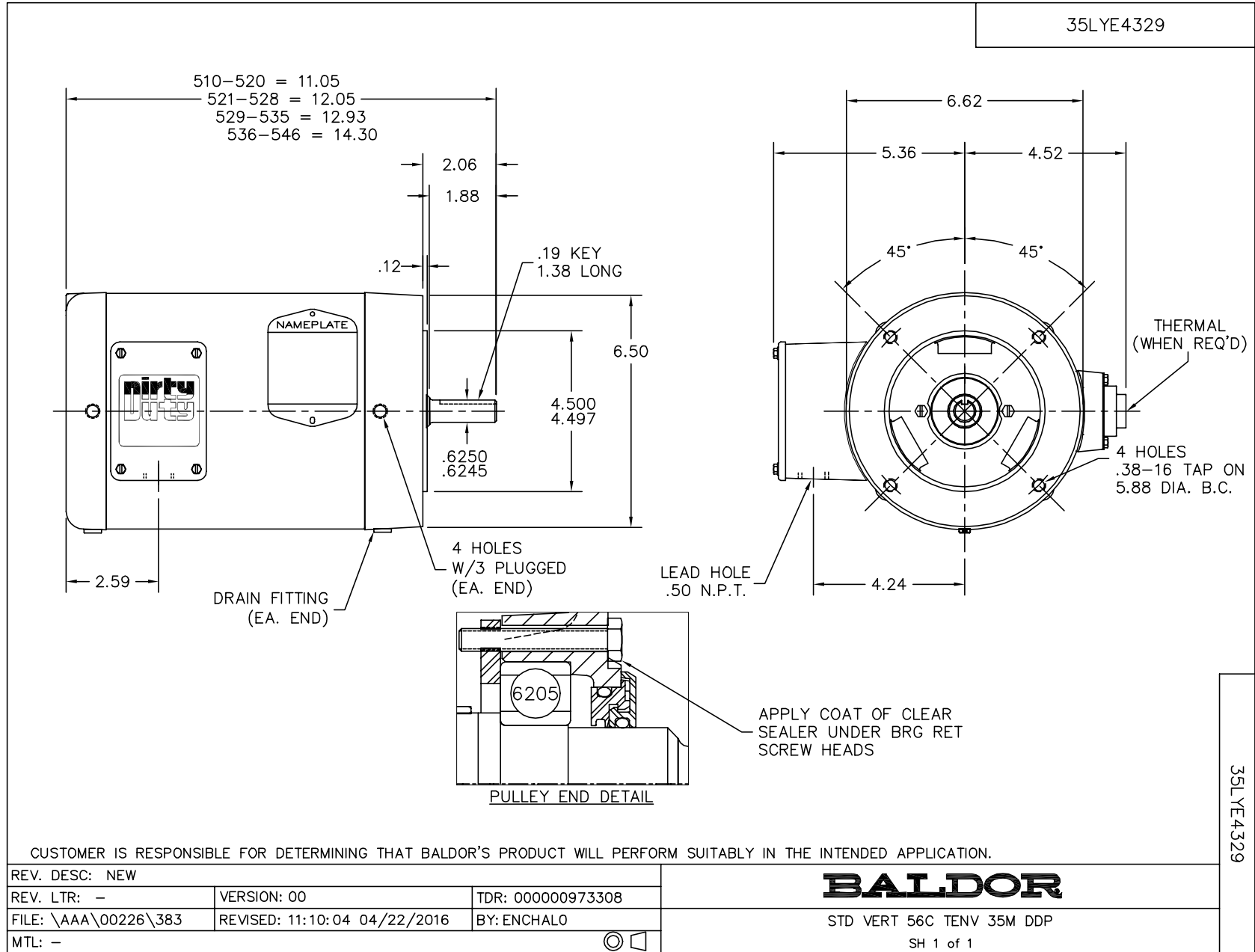

CD0005



LOW VOLTAGE
(2Y)

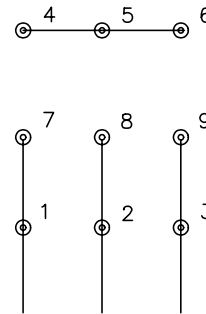

LINE

HIGH VOLTAGE
(1Y)



LINE

NOTES:

1. INTERCHANGE ANY TWO LINE LEADS TO REVERSE ROTATION.
2. OPTIONAL THERMOSTATS ARE PROVIDED WHEN SPECIFIED.
3. ACTUAL NUMBER OF INTERNAL PARALLEL CIRCUITS MAY BE A MULTIPLE OF THOSE SHOWN ABOVE.
4. LEAD COLORS ARE OPTIONAL. LEADS MUST ALWAYS BE NUMBERED AS SHOWN.

REV. DESC: REVISE TO SHOW OPTIONAL COLORS			
REV. LTR: E	BY: JLP	REVISED: 01/19/99 10:15	TDR: 0171435
90000		FILE: AAA00005140	MDL: -
		MTL: -	

BALDOR ELECTRIC Co.

3PH, DV, 9 LEADS

CD0005