

# SLIDE RAIL COUPLING SRC-6

Designed for use with  
our 6-inch flanged  
solids-handling pumps



## LOCATION

This SRC-6 is designed for wet wells, tanks, or lift stations where it is necessary to remove a pump from service and reinstall the pump without maintenance personnel entering the pit to unbolt the pump flanges.

## STATIONARY ELBOW

Cast iron ASTM A-48 class 30

## MOVABLE FITTING

Ductile iron ASTM A-536

## GUIDE RAIL CAP

**Bracket:** 304 stainless steel

**Plugs:** ductile iron ASTM A-536-84

## HARDWARE

304 series stainless steel

## O-RINGS

Buna-N, 70 ±5 Duro.

## GASKETS

Rubber

## PAINT

Air dry enamel, water based.

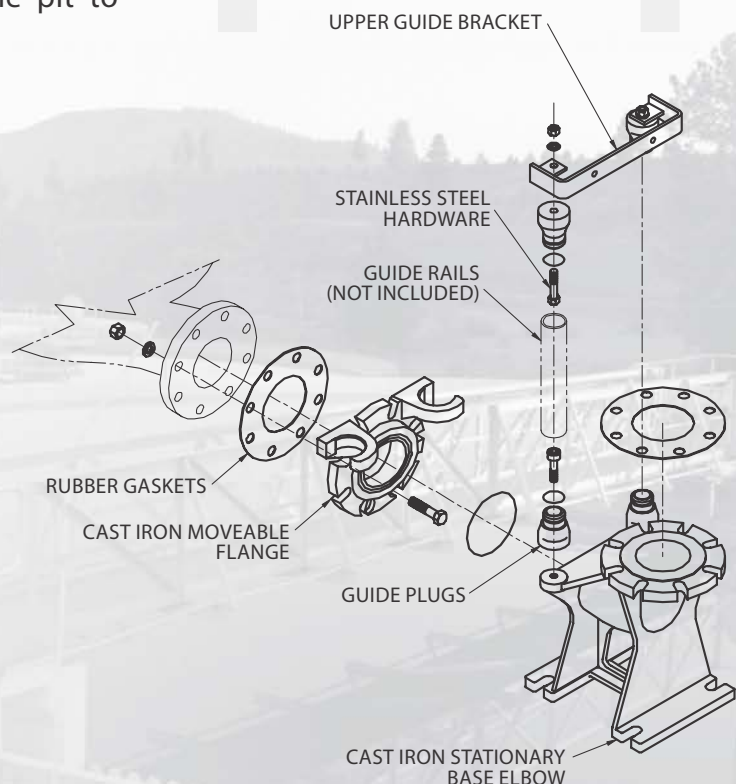

inches  
(mm)

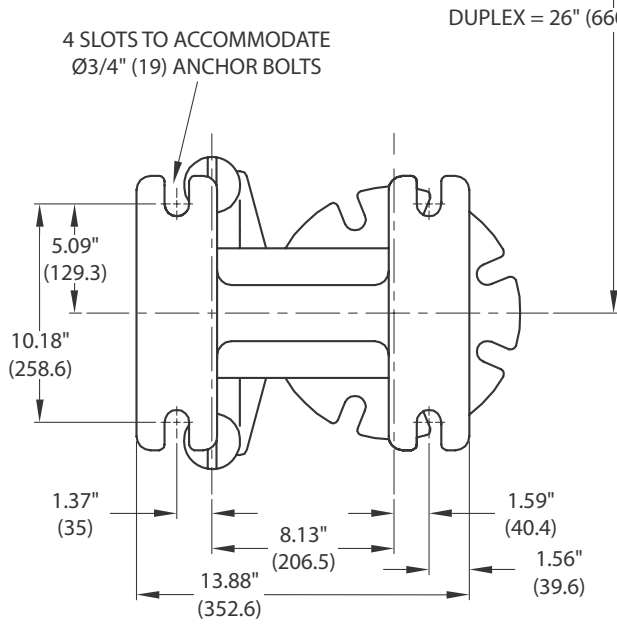
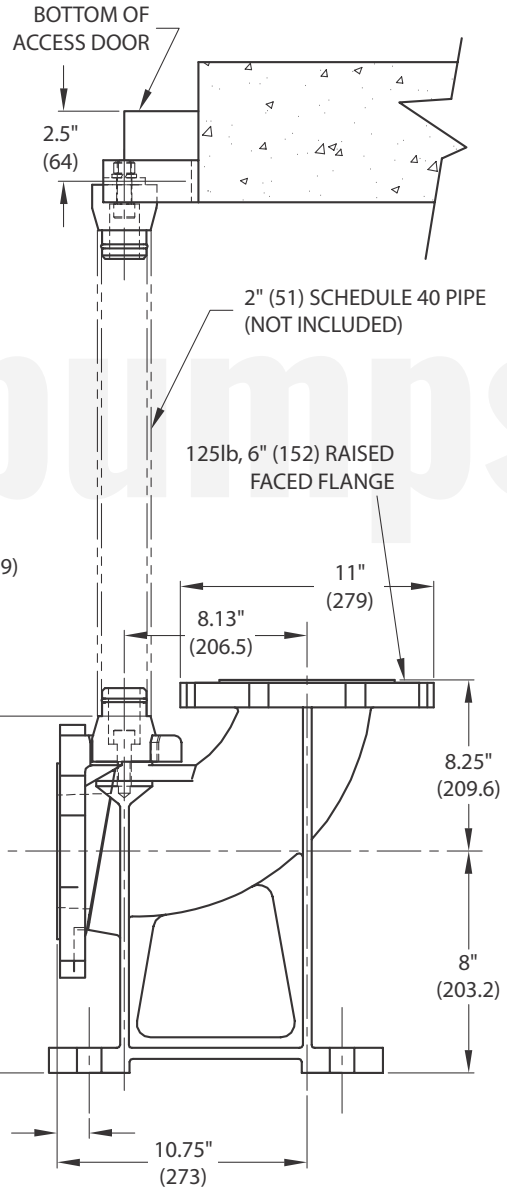
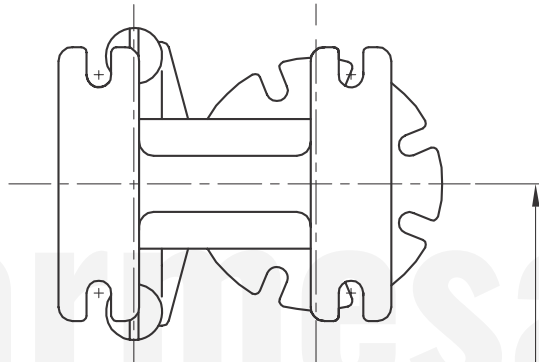
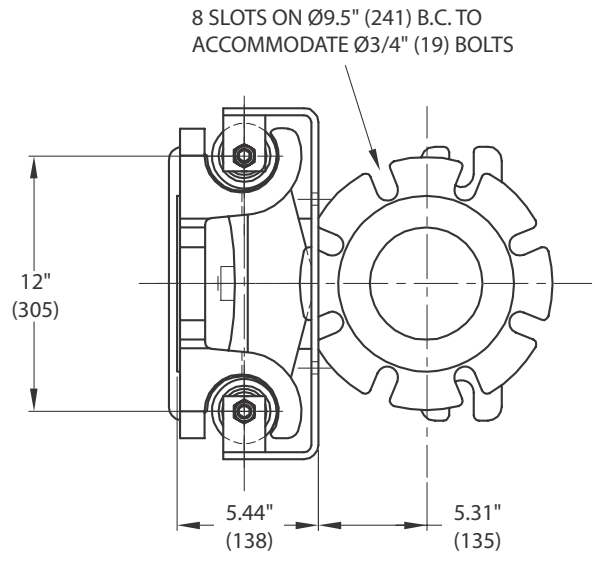
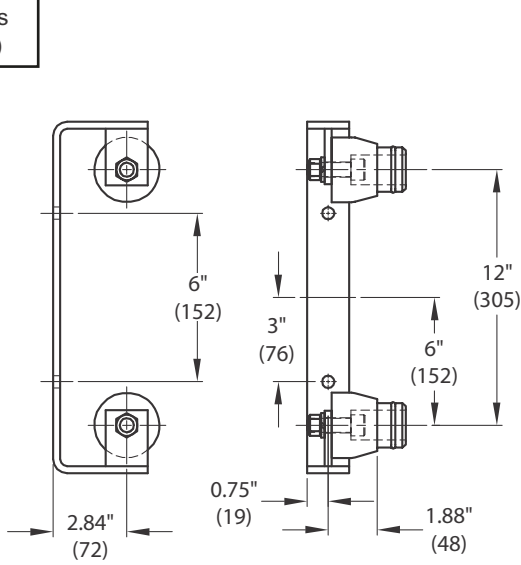

DUPLEX = 26" (660) TO 32.25" (819)

MODEL	PART No.	SIZE	RAILS	COUPLING	WEIGHT (pounds)
SRC6	62170802	6"	2"	w/ upper guide bracket	180
SRC6-FA	62170816	6"	-	flygt adapter	42