

BERKELEY®

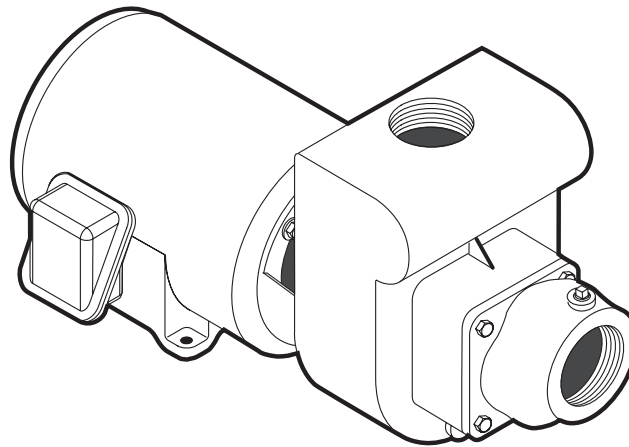

“LT” Series

Installation/Operation/Parts

For further operating, installation, or maintenance assistance:

Call 1-888-782-7483

Important Safety Instructions

SAVE THESE INSTRUCTIONS - This manual contains important instructions that should be followed during installation, operation, and maintenance of the product. Save this manual for future reference.

▲ This is the safety alert symbol. When you see this symbol on your pump or in this manual, look for one of the following signal words and be alert to the potential for personal injury!

▲ DANGER indicates a hazard which, if not avoided, *will* result in death or serious injury.

▲ WARNING indicates a hazard which, if not avoided, *could* result in death or serious injury.

▲ CAUTION indicates a hazard which, if not avoided, *could* result in minor or moderate injury.

NOTICE addresses practices not related to personal injury. Keep safety labels in good condition. Replace missing or damaged safety labels.

California Proposition 65 Warning

▲ WARNING This product and related accessories contain chemicals known to the State of California to cause cancer, birth defects or other reproductive harm.

General Safety

▲ WARNING Risk of burns. Do not touch an operating motor. Motors can operate at high temperatures. To avoid burns when servicing pump, allow it to cool for 20 minutes after shut-down before handling.

Do not allow pump or any system component to freeze. To do so will void warranty.

Pump water only with this pump.

Periodically inspect pump and system components.



Wear safety glasses at all times when working on pumps.

Keep work area clean, uncluttered and properly lighted; store properly all unused tools and equipment.



Make workshops childproof; use padlocks and master switches; remove keys.

Keep visitors at a safe distance from the work areas.

▲ WARNING Risk of explosion. Pump body may explode if used as a booster pump unless relief valve capable of passing full pump flow at 75 psi is installed.

 WARNING

<p>Hazardous voltage. Can shock, burn, or cause death.</p> <p>Ground pump before connecting to power supply. Disconnect power before working on pump, motor or tank.</p>

- ▲** Wire motor for correct voltage. See “Electrical” section of this manual and motor nameplate.
- ▲** Ground motor before connecting to power supply.
- ▲** Meet National Electrical Code, Canadian Electrical Code, and local codes for all wiring.
- ▲** Follow wiring instructions in this manual when connecting motor to power lines.

 WARNING

<p>Hazardous pressure! Install pressure relief valve in discharge pipe.</p> <p>Release all pressure on system before working on any component.</p>

Limited Warranty

BERKELEY warrants to the original consumer purchaser (“Purchaser” or “You”) of the products listed below, that they will be free from defects in material and workmanship for the Warranty Period shown below.

Product	Warranty Period
Water Systems:	
Water Systems Products — jet pumps, small centrifugal pumps, submersible pumps and related accessories	<i>whichever occurs first:</i> 12 months from date of original installation, or 18 months from date of manufacture
Pro-Source® Composite Tanks	5 years from date of original installation
Pro-Source® Steel Pressure Tanks	5 years from date of original installation
Pro-Source® Epoxy-Lined Tanks	3 years from date of original installation
Sump/Sewage/Effluent Products	12 months from date of original installation, or 18 months from date of manufacture
Agricultural/Commercial:	
Centrifugals – close-coupled motor drive, frame mount, SAE mount, engine drive, VMS, SSCX, SSHM, solids handling, submersible solids handling	12 months from date of original installation, or 24 months from date of manufacture
Submersible Turbines, 6” diameter and larger	12 months from date of original installation, or 24 months from date of manufacture

Our limited warranty will not apply to any product that, in our sole judgement, has been subject to negligence, misapplication, improper installation, or improper maintenance. Without limiting the foregoing, operating a three phase motor with single phase power through a phase converter will void the warranty. Note also that three phase motors must be protected by three-leg, ambient compensated, extra-quick trip overload relays of the recommended size or the warranty is void.

Your only remedy, and BERKELEY’s only duty, is that BERKELEY repair or replace defective products (at BERKELEY’s choice). You must pay all labor and shipping charges associated with this warranty and must request warranty service through the installing dealer as soon as a problem is discovered. No request for service will be accepted if received after the Warranty Period has expired. This warranty is not transferable.

BERKELEY SHALL NOT BE LIABLE FOR ANY CONSEQUENTIAL, INCIDENTAL, OR CONTINGENT DAMAGES WHATSOEVER. THE FOREGOING LIMITED WARRANTIES ARE EXCLUSIVE AND IN LIEU OF ALL OTHER EXPRESS AND IMPLIED WARRANTIES, INCLUDING BUT NOT LIMITED TO IMPLIED WARRANTIES OF MERCHANTABILITY AND FITNESS FOR A PARTICULAR PURPOSE. THE FOREGOING LIMITED WARRANTIES SHALL NOT EXTEND BEYOND THE DURATION PROVIDED HEREIN.

Some states do not allow the exclusion or limitation of incidental or consequential damages or limitations on the duration of an implied warranty, so the above limitations or exclusions may not apply to You. This warranty gives You specific legal rights and You may also have other rights which vary from state to state.

This Limited Warranty is effective June 1, 2011 and replaces all undated warranties and warranties dated before June 1, 2011.

In the U.S.: BERKELEY, 293 Wright St., Delavan, WI 53115
In Canada: 269 Trillium Dr., Kitchener, Ontario N2G 4W5

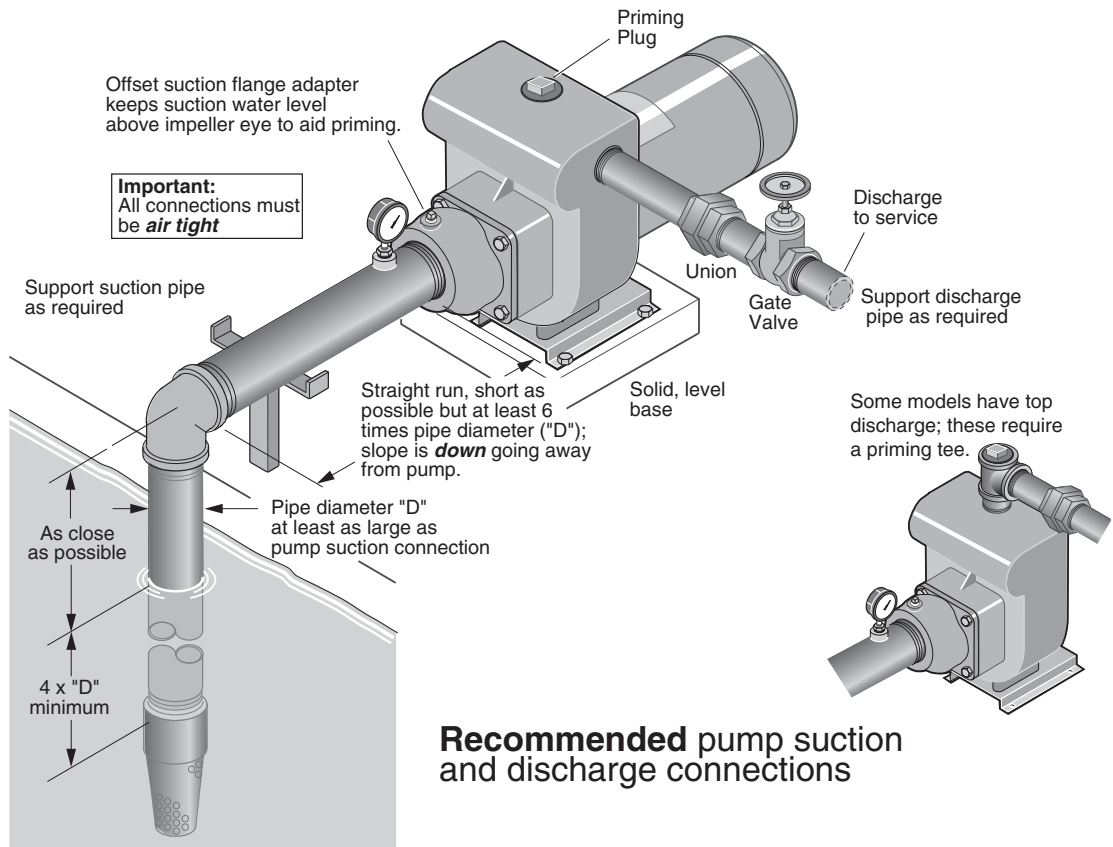

Figure 1

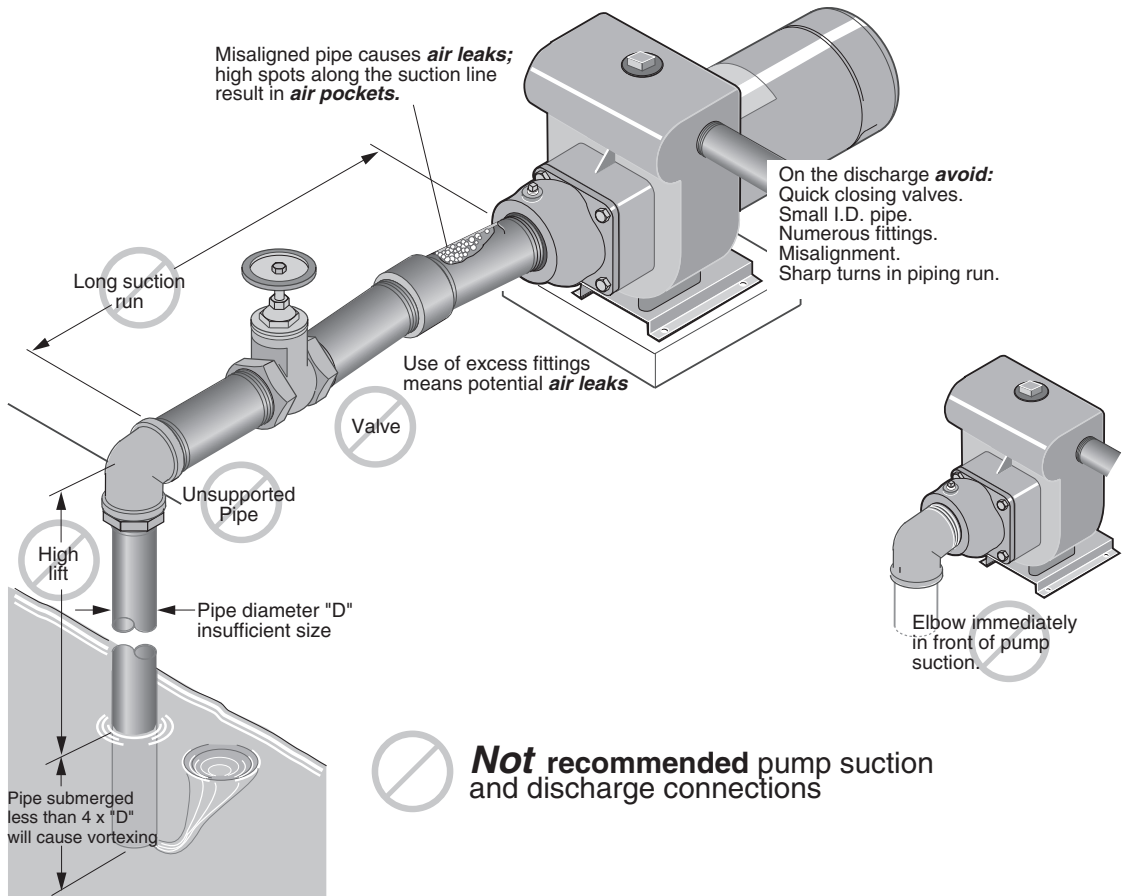

Figure 2

Location Of Unit

Locate the pump as near the liquid source as possible, using a short, direct suction pipe. Keep the static suction lift (vertical distance between the center line of the pump and the liquid level) to a minimum. Mount the pump on a solid, level foundation, which provides a rigid and vibration-free support. It should be located where the unit is readily accessible for service and maintenance. The pump should be protected against flooding and excessive moisture.

Piping

Both suction and discharge piping should be independently supported at a point near the pump to avoid strains being placed on the pump. Start all piping at pump to avoid strains left by a gap at last connection.

Suction Piping

The suction pipe must be kept free of leaks. The suction pipe must have a gradual slope upward to the pump. Avoid any fittings which may cause an air trap. On units that have a suction fitting, a check valve is a built-in feature and no foot valve is required.

Discharge Piping

A gate valve and union should be installed in the discharge line. For removal of the pump for service, close the gate valve, and disconnect at union.

Electrical Information

⚠ WARNING Hazardous voltage. Disconnect power at service panel before connecting motor. Single phase motors come factory wired for 230 volt operation. Do not alter wiring in single phase motors. Match motor voltage to power supply voltage. Do not connect three phase motors to single phase power supply or single phase motors to three phase power supply.

- Ground motor before connecting to electrical power supply.
- Failure to ground motor can cause severe or fatal electrical shock hazard.
- Do not ground to a gas supply line.
- To avoid dangerous or fatal electrical shock, turn OFF power to motor before working on electrical connections.
- Supply voltage must be within $\pm 10\%$ of nameplate voltage. Incorrect voltage can cause fire or seriously damage motor and voids warranty. If in doubt consult a licensed electrician.
- Use wire size specified in Wiring Chart. If possible, connect pump to a separate branch circuit with no other appliances on it.

Wiring

1. Install, ground, wire and maintain this pump in accordance with your local electrical code and all other codes and ordinances that apply. Consult your local building inspector for local code information.
2. Ground the pump permanently using a wire of size and type specified by local or National Electrical Code. **Do not ground to a gas supply line.**
3. Connect ground wire first. Connect to ground first, then to green grounding terminal provided (identified as GRD or \oplus). Make ground connection to this terminal. Do not connect motor to electrical power supply until unit is permanently grounded; otherwise serious or fatal electrical shock hazard may be caused.
4. For best ground connection, connect to a grounded lead in the service panel or to a metal underground water pipe or well casing at least 10 ft. long. If plastic pipe or insulated fittings are used, run ground wire directly to the metal well casing or use ground electrode furnished by the power company.

⚠ WARNING Hazardous voltage. Before using pump, check your motor nameplate for voltage. Your electric supply voltage and the stamped nameplate voltage must agree.

Motors stamped 200 volts only or 230 volts only, must be used with that voltage only. Motors stamped with two voltages (for example 230/460 volts), may be used with either supply voltage. For these motors check connections against wiring diagram on motor nameplate and make any changes necessary to agree with your supply voltage. If in doubt, call a licensed electrician. Incorrect voltage will cause serious damage to the motor. Some models are equipped with three phase motors. Three phase motors require magnetic starters.

To check motors for proper rotation: The shaft can be seen through the motor - pump adapter bracket. A mark can be made on the shaft to make it easier to notice rotation. Jog the motor (start it briefly) and note the rotation. It should rotate clockwise when viewed from the motor-end. If rotation is not clockwise, see motor nameplate for hookup information. BE SURE power is off to the motor when working on electrical connections.

⚠ WARNING Risk of burns. Motor normally operates at high temperature and will be too hot to touch. Before handling pump or motor, stop motor and allow it to cool for 20 minutes.

Priming The Pump

A tee installed in the discharge opening of the pump, and provided with a priming plug at the top position, will enable you to fill the pump with liquid. Once filled and the priming plug replaced, the pump will prime. The pump should prime itself time after time, as long as the built-in check valve functions.

Service

⚠ WARNING Never run pump dry. Running pump without water may cause pump to overheat, damaging seal and possibly causing burns to persons handling pump. Fill pump with water before starting.

⚠ WARNING Never run pump against closed discharge. To do so can boil water inside pump, causing hazardous pressure in unit, risk of explosion and possibly scalding persons handling pump.

Maintenance

Little or no maintenance to pump is required other than possible replacement of shaft seal after a reasonable period of operation (see Page 8).

Lubricate motor according to motor manufacturer’s in-structions. Periodic greasing is required for most motors.

TABLE I – Recommended Wire and Fuse Sizes

MOTOR HP	PHASE	VOLTS	MAX. LOAD AMPS	BRANCH FUSE* RATING AMPS	DIAMETER IN FEET FROM MOTOR TO METER				
					0' TO 100'	101' TO 200'	201' TO 300'	301' TO 400'	401' TO 500'
					WIRE SIZE				
3	1	230	17.0	25	12	12	10	8	8
3	3	230	9.6	15	14	14	12	12	10
3	3	460	4.8	15	14	14	14	14	14
5	1	230	28.0	40	8	8	8	6	6
5	1	200	32.2	50	8	8	8	6	6
5	3	200	17.5	25	10	10	10	8	8
5	3	230	15.2	20	12	12	10	10	8
5	3	460	7.6	15	14	14	14	14	14

* Time delay fuse or circuit breakers are recommended in any motor circuit.

NOTICE: BE SURE lead wire opening on end of motor is fully sealed when conduit or a pressure switch is not used. Failure to seal it properly will allow dirt, rain, bugs, etc. to enter back compartment of motor through conduit opening and cause switch malfunction.

Pump Storage

Drain pump to prevent freezing.

Keep motor dry and loosely covered. Do not wrap with plastic sheeting; trapped moisture could cause corrosion or insulation deterioration.

NOTICE: A good rust inhibitor in the liquid end of cast iron pumps is recommended to prevent excessive corrosion.

Pump Start-Up After Storage

Replace all drain plugs and close all drain valves in the system.

Be sure all connections are tightly sealed.

After initial check is made, fill pump according to *Priming the Pump*.

Shaft Seal Replacement

NOTICE: The highly polished and lapped faces of the seal are easily damaged. Follow instructions and handle the seal with care.

⚠ WARNING Hazardous voltage. Be sure unit is grounded and power disconnected before attempting any work on pump or motor.

Removal Of Old Seal

Refer to Figure 3 for Mechanical Seal parts identification.

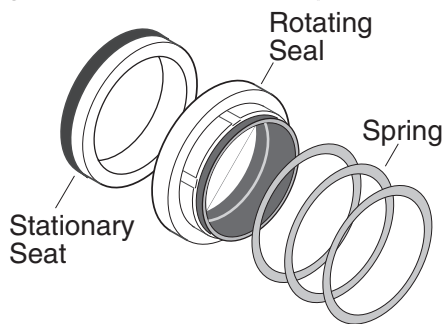

Figure 3

1. Disconnect all power to pump.
2. Close isolation valves to cut pump off from system.
3. Drain pump; be sure to vent pump.
4. Remove motor hold down bolts and bolts holding adapter/seal plate (Ref. No. 6, *Repair Parts*) to pump body (Ref. No. 20). Slide motor, adapter/ seal plate and impeller (Ref. No. 12) backward to clear pump body.
5. Remove impeller screw and washer from end of shaft and slide impeller off of shaft.
6. Unbolt adapter/seal plate from motor.

7. Use two screwdrivers (Figure 4) or bearing puller to carefully separate motor from adapter/seal plate, bringing rotating half of seal (Ref. No. 10) off with adapter/seal plate. Shaft sleeve (Ref. No. 2A) may come off with seal.

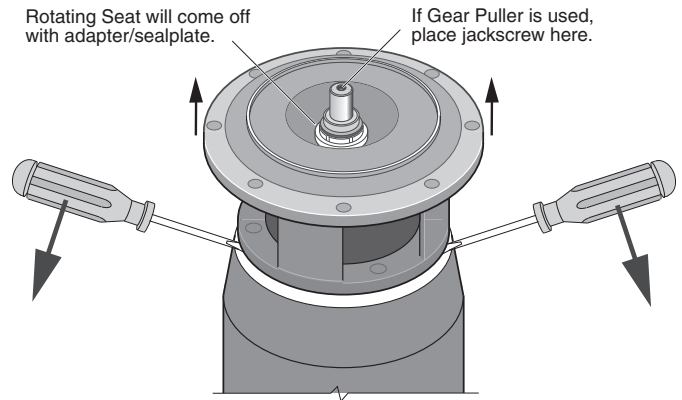

Figure 4

8. Use hammer, if necessary, to drive shaft sleeve out of seal. Clean up shaft sleeve with emery paper if necessary.
9. Place adapter/seal plate face down on bench and drive old stationary half of seal out of adapter/ seal plate by carefully taping with screwdriver and hammer (Figure 5).

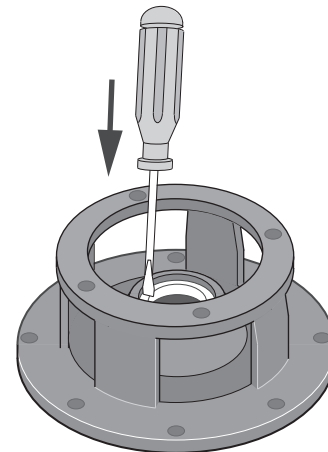

Figure 5

10. Use a wire brush to thoroughly clean adapter/seal plate cavity. Be sure all dust and grime are out of seal cavity before installing new seal.

Installing New Seal

1. **NOTICE:** Seal faces are highly polished and lapped. Handle with care. Any mar, nick or scratch on seal face will cause it to leak. BE SURE to install with polished faces toward each other.
2. Clean polished surface of ceramic seat with clean cloth.
3. Wet O-Ring around ceramic seat with liquid soap.
4. Press stationary (ceramic) half of seal into cavity firmly and squarely with thumb pressure. If it does not seal properly, remove and place face up on bench. Re-clean adapter/seal plate cavity. Seal should now seat correctly.
5. If seal does not seat after recleaning adapter/seal plate cavity, place a cardboard washer over polished face of seal and carefully press into place using a piece of 1" standard pipe as a press. (Figure 6).

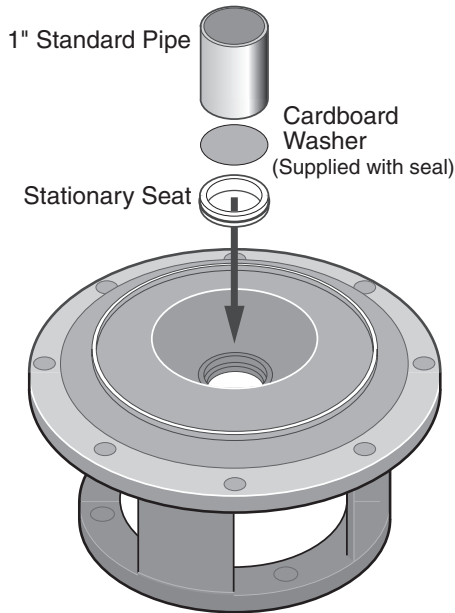
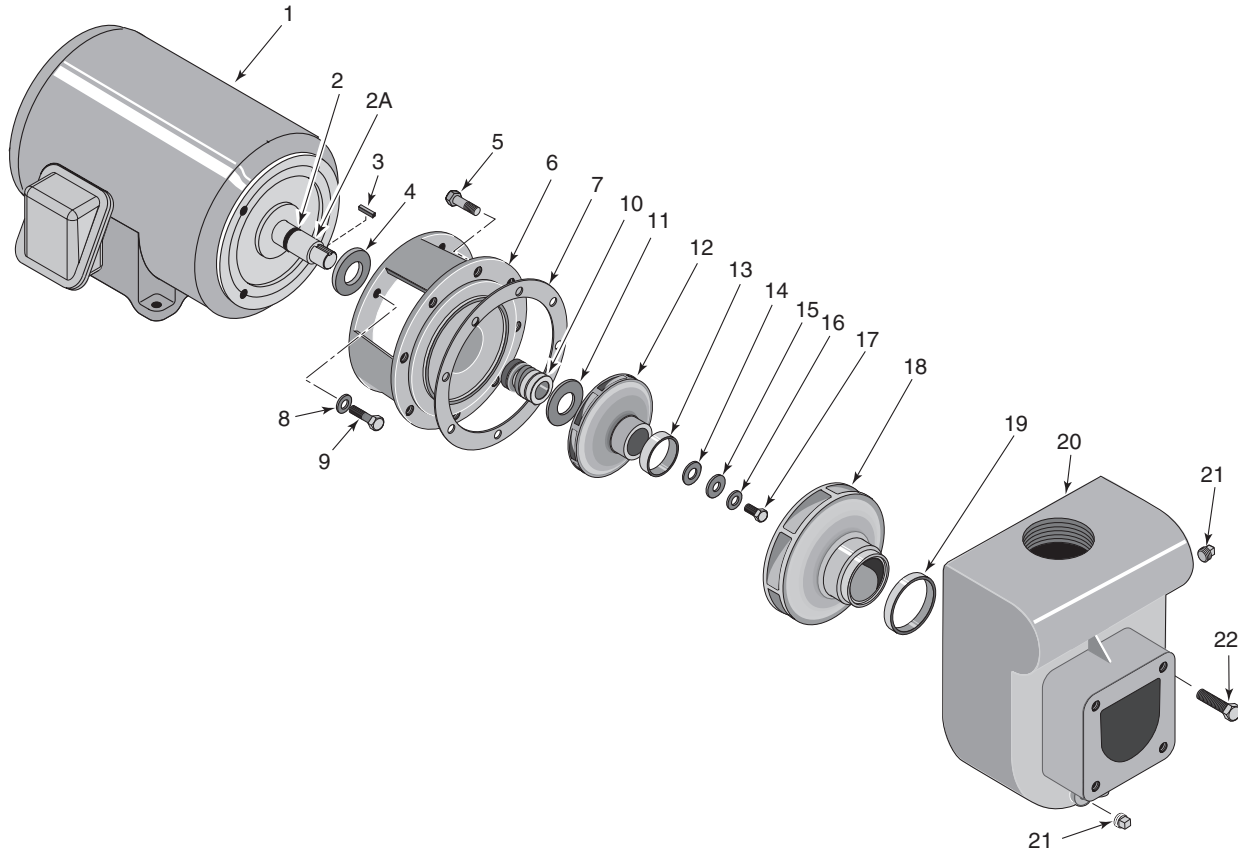

Figure 6

NOTICE: BE SURE you do not scratch seal face.

6. Dispose of cardboard washer and recheck seal face to be sure it is free of dirt, foreign particles, scratches and grease.
7. Inspect shaft and shaft sleeve to be sure they are clean.
8. Re-install O-Ring, shaft sleeve and slinger (Ref. No. 4) on shaft.

NOTICE: A small amount of grease or Never-Seez under shaft sleeve will help prevent shaft and sleeve from freezing together when pump is in service.
9. Remount adapter/seal plate to motor, being careful not to scratch seal face.
10. Apply liquid soap to inside diameter and outside face of rubber drive ring on rotating half of seal.
11. Slide seal assembly onto shaft sleeve (sealing face first) far enough so that seal spring is located on shaft sleeve. **NOTICE:** Be careful not to nick carbon seal face when passing it over end of shaft sleeve.
12. Slide impeller and gaskets (Ref. Nos. 12 and 11) onto shaft with key (Ref. No. 3) in position. Be sure to maintain proper order as shown in *Repair Parts*.
13. Install washer, gaskets, and impeller screw (Ref. Nos. 14, 15, 16, 17) on end of shaft and tighten screw until it is snug. This should locate seal in place and bring seal faces together.
14. Re-install motor, adapter and impeller assembly on volute, using new gasket (Ref. No. 7).
15. Re-install motor hold-down bolts.
16. Check all bolts for tightness.
17. Pumps below water level: Close drains; open isolation valves to fill pump. Pumps above water level: Prime pump. Open isolation valves if they were closed at disassembly.
18. When pump is full, close air vents.
19. Reconnect power to pump and system is ready for operation.



Ref.	Description	Qty.	3 HP, LTM-3 S40099 S40100	5 HP, LTM-5 S40102 S40103	3 HP, LTH-3 S40093 S40094	5 HP, LTH-5 S40097 S40096
1	Motor - 60 Cycle - 230V, Single Phase	1	C218-177	C218-180	C218-177	C218-180
	Motor - 60 Cycle - 230/460V, Three Phase	1	C218-179BD	C218-182BD	C218-179BD	C218-182BD
2	O-Ring	1	U9-265			
2A	Sleeve	1	C23-58			
3	Key - Square	1	U65-42A			
4	Water Slinger - Single Phase	1	C69-15			
	Water Slinger - 230/460V, Three Phase	1	C69-16	C69-15	C69-16	C69-15
5	Capscrew - 3/8 - 16 x 7/8" Lg.	8	*			
6	Adapter	1	C2-66			
7	Gasket - Adapter	1	C20-46			
8	Lockwasher - 3/8"	4	*			
9	Capscrew - 3/8 - 16 x 1" Lg.	4	*			
10	Shaft Seal	1	U9-433SS			
11	Gasket - Seal	1	C20-101			
12	Impeller	1	C5-246	C5-247	C5-248	C5-249
13	Wear Ring	1	J23-5	C23-14	J23-5	
14	Gasket	1	C20-100			
15	Washer - Impeller	1	C43-45SS			
16	Gasket	1	C43-46			
17	Screw - Impeller - 3/8 - 16 x 3/4" Lg.	1	U30-72SS			
18	Volute Diffuser (w/Wear Ring, Ref. No. 13)	1	C101-126	C101-126B	C101-132	
19	Diffuser Ring	1	C21-2			
20	Pump Body	1	C76-12	C76-12C	C76-12B	C76-12
21	Pipe Plug - 1/4" NPT	2	*			
22	Capscrew - 5/16 - 18 x 3/4" Lg.	4	*			

* Purchase locally.

Order Online: www.PumpCatalog.com

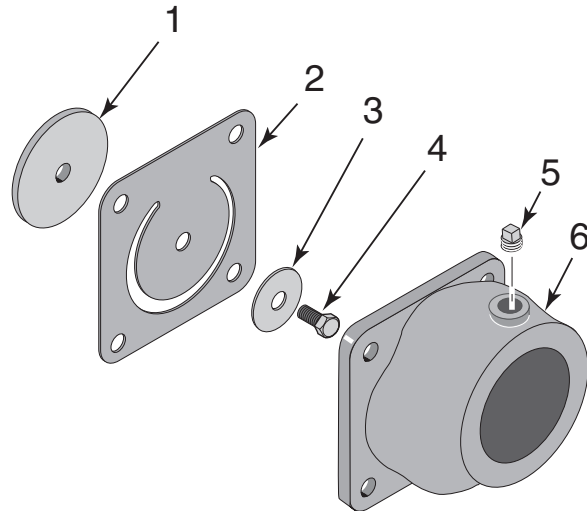

Ref.	Description	Qty.	Part Number
1	Valve Plate	1	C61-5SS
2	Gasket - Flange	1	C20-15
3	Valve Washer	1	C43-15SS
4	Machine Screw 1/4-20 x 1/2"	1	*
5	Pipe Plug - 1/4" NPT Sq. Hd.	1	*
6	Suction Flange 2" NPT	1	C3-22A
	Suction Flange 2-1/2" NPT	1	C3-74
	Suction Flange 3" NPT	1	C3-74B
*	Nut, 1/4-20, Hex	1	35407-0071
	Suction Flange Assembly:		
	Complete 1-1/2" NPT		C203-22
	Complete 2" NPT		C203-22A

* Purchase locally.

Order Online: www.PumpCatalog.com

This page intentionally left blank

Order Online: www.PumpCatalog.com