

C41 • C51 • C61 SERIES

Pump Manual

HORIZONTAL CLOSE COUPLED

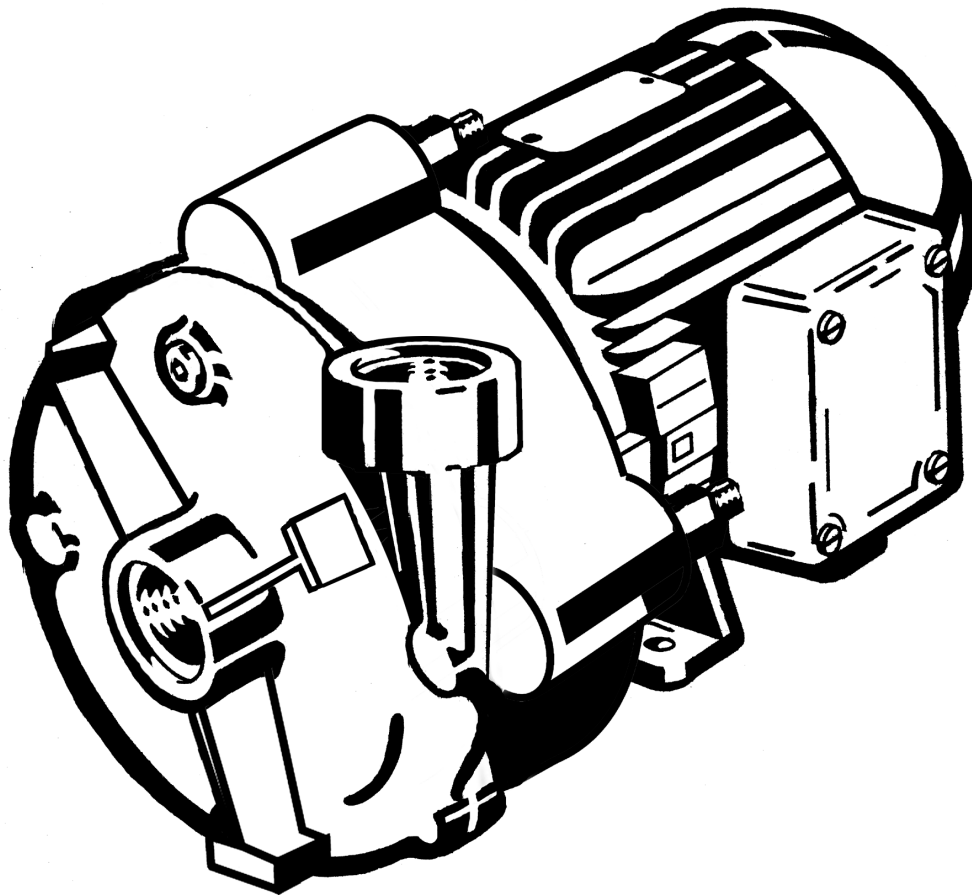

MTH PUMPS

401 West Main Street • Plano, IL 60545-1436
Phone: 630-552-4115 • Fax: 630-552-3688
Email: SALES@MTHPUMPS.COM
<http://WWW.MTHPUMPS.COM>

1. General Instructions

CENTRIFUGAL PUMPS

- A. Inspection of Equipment
- B. Storage
- C. Placing Stored Pumps Into Service
- D. Recommended Spare Parts

When properly installed and given reasonable care and maintenance, centrifugal pumps should operate satisfactorily for many years. The C Series pumps use tight running clearances to build pressure. Abrasive particles in high enough concentrations, can eventually open up the close clearances between the impeller and the casing, thus reducing pressure output. To avoid this, careful selection and use of a low resistance suction strainer should be considered. For critical services it is recommended that you keep an identical pump for stand-by use.

1A Inspection of Equipment

Immediately upon receipt of the shipment, inspect the equipment for damage or missing components. Check the shipping manifest and report any damage or shortage to the Transportation Company's local agent. Inspect the crate and any wrapping material before discarding. Parts or accessories are sometimes wrapped individually or fastened to the skid.

Put the instructions that came with the shipment in a safe place where they will be available to those who will be using them for installation and service.

1B Storage

If the pump is to be stored before use, it should be inspected as described in 1A, recrated and stored in a dry location. Standard shipping containers are not suitable for outdoor storage. In some areas, it may be necessary to cover the pump's exterior surface with oil or other rust inhibiting coating. All units are tested at the factory with a water/corrosion inhibitor solution, some of which will remain inside the pump upon receipt. If units are flushed out prior to storage, this inhibitor will be

removed and proper care must be taken to prevent product deterioration from improper storage.

For storage beyond 30 days, a corrosion inhibiting protective fluid should be added to the internal pump cavities. Fluids used in the pump should be selected for compatibility with pump materials. This is very important when optional seal and gasket materials have been used. Protective caps on the inlet and outlets should also be used. Caps alone are not sufficient protection.

1C Application Considerations

1C1 Electrical Wiring

All electrical equipment and wiring should conform to Local and National Electrical Codes. Use the motor manufacturer's instructions for connecting the motor. Note the correct rotation and wiring diagrams on the assembly. Make sure the motor rotation and speed matches that required for the pump. When making electrical connections to motors provided with threaded stud electrical terminals, the recommended torque should be 13-16 inch-lbs. Applying torque in excess of this range may cause damage.

1C2 Construction Materials

While it is reasonable to assume that good judgement has been used in selecting all the materials in the pump for compatibility with process fluids, actual conditions sometimes vary from original expectations. Also, typical material selection charts do not consider all the temperature, pressure, and fluid variables. The customer's engineer should be consulted for final judgment on the best materials for critical process applications.

1C3 Valves

If a shutoff valve is necessary in the suction line, use a gate, ball, butterfly, or other full port valve. Globe or other flow restricting valves, can in some cases, reduce pump flow or increase chances of cavitation.

A swing check valve in the suction

line is recommended even when the pump inlet is only slightly higher than the fluid source to aid in priming. It should be the same size as the pump inlet or sized based on reasonable fluid friction losses.

A foot valve is recommended when lifting fluid from a sump. This will save wear and tear on any pump, even those equipped with self priming equipment.

A low resistance Suction Strainer is recommended immediately ahead of the pump on any newly constructed system. This is advisable due to the probability that foreign material large enough to damage pump clearances may remain, even though the piping has been flushed.

Valves in the outlet piping of a centrifugal pump should be closed, or nearly closed, when the pump is started. This will reduce the start-up load on the pump and motor. Never start the pump with the discharge valve fully open, unless system friction losses are substantial enough to prevent the pump from operating at "run out," otherwise cavitation or motor overload may occur.

Inlet valving should be fully open when starting any pumping system. Without some fluid in the pump at startup, the unit can gall and lock up the impeller. Always fill the pump and vent it of air for best pump life. Violent pump failure will result from continued operation with the inlet valve closed.

1C4 NPSH (Net Positive Suction Head)

The NPSH required varies with every size and capacity of pump. The NPSH required by your unit can be obtained from the performance curves or from your MTH representative.

If the NPSH available is not equal to or greater than that required by the pump, it must be increased or a different pump selected. The usual method for increasing NPSH is to raise the static head on the pump inlet, (HS). By definition, NPSH

means: “Net Positive Suction Head” above the vapor pressure of the pumped liquid, available at the centerline of the pump. It should always be given in feet of pumped liquid. The NPSH is actually a measurement of the amount of energy available in the pumped liquid to produce the required absolute entrance velocity in the pump. If a pump requires more energy (or NPSH) than is available at a given capacity, the pressure at the inlet will fall below the vapor pressure of the pumped liquid and fluid vaporization and loss of performance will result.

P_s = Pressure in the suction vessel in PSIA.

P_{vp} = Vapor pressure of the pumped fluid in PSIA.

H_s = Static height of the pumped fluid above (+) or below (-) the centerline of the pump.

H_f = All friction losses from the vessel to the pump.

$$NPSH = 2.31 \left(\frac{P_s - P_{vp}}{\rho \cdot g} \right) + H_s - H_f$$

For boiling liquids, P_s and P_{vp} are equal. This item then becomes

zero and can be omitted from the equation.

1C5 Noise

Motors, bearings, and other rotating components add to noise, which sometimes create objectionable harmonics.

Careful pump installation can contribute to noise reduction. Proper alignment of the pump and driver is essential. Adequate supports for the inlet and discharge piping is equally important. A degree of noise reduction may be obtained when the pumping unit is supported free of building structures by the use of vibration isolators, flexible piping and conduit connections. To separate motor noise and vibration from the fluid and piping structure, using a flexible elastomer-coupled (long coupled) configuration is very desirable.

1C6 Freezing

When ambient temperatures drop below the freezing point of the fluid, consideration should be given to heating, insulating, or draining the pump. If you

choose to drain the pump, first remove the drain plugs and drain the suction and discharge lines. Carefully blow out the pump with compressed air to clear all internal cavities of fluid.

1D Recommended Spare Parts

FOR ROUTINE MAINTENANCE:
Only a complete set of “O” ring gaskets and a mechanical seal are recommended. Should additional components show wear, they are available from stock at the factory (see the C Series price brochure).

FOR SERVICING A PUMP THAT DOES NOT PRODUCE RATED CAPACITY OR HEAD :
“O” ring gaskets, impeller, mechanical seal, and pump casing.

FOR CRITICAL SERVICES:
A duplex installation, with two identical pumping units in parallel, is the safest, and many times the most cost effective choice where downtime cannot be tolerated.

C41 • C51 • C61 SERIES

2. Service

Pump Ends

- A. Preliminary
- B. Disassembly
- C. Inspection of Components
- D. Reassembly
- E. Testing and Final Adjustments

2A Preliminary

Before attempting any service on the pump or motor, disconnect the electrical power to the pump motor. If the pump and motor are to be removed as a unit, note the wiring configuration.

1. Disconnect the inlet and outlet piping before unbolting the pump and motor.
2. Unbolt the motor from the base and remove the unit. All work on the unit should be performed on an elevated workbench whenever possible.

The disassembly and reassembly procedures are broken into two sections:

- B — Disassembly
- D — Reassembly

An exploded view of the unit, Figure 1, is provided for referencing the numbers in the following procedures, i.e. (#84), motor bracket.

2B Disassembly

The following tools and equipment are needed for disassembly.

1. Soft plastic or wooden mallet.
2. 5/8” wrench or socket.
3. 10 mm socket wrench.
4. 13 mm wrench or socket.
5. 5 mm Allen wrench.

6. Penetrating oil.
7. 3/4" wood dowel (Approx. 6" long).
8. Small O.D. Snap Ring Pliers.
9. Cealube G or similar glycol base lubricant. (DO NOT use petroleum products.)

To disassemble the pump:

1. Remove all liquid from the pump.
2. Remove the casing (#108) by removing the jam nuts (#20) from the casing studs (#5). Slide the casing off and rest it on the studs.
3. Remove the impeller (#11) by removing the 10mm Bolt (#19) and washer (#41), then sliding forward.(may require a gear puller)
4. Remove the snap ring (#4) from the shaft using snap ring pliers.

5. Remove the impeller key (#23) from the shaft.
6. Remove the rotating element from the shaft. The element normally adheres tightly to the shaft and some force may be necessary to remove it. This is common and, if care is taken, the element can be reassembled and reused. **It is recommended that a new rotating element be used for reassembly.** DO NOT attempt to remove the seal using a screwdriver or other sharp object. Extensive damage to the shaft or element could occur.
7. Remove the motor bracket. Loosen and remove the four socket head screws (#33A) with a 5 mm Allen wrench. Note: The rotating element must be removed before the motor bracket can be removed. It is not necessary to remove the adjusting screws # 33.

8. Remove the seat portion of the seal from the motor bracket.

- a. Place the motor bracket face down on a flat surface.
- b. Look into the opening in the center of the motor bracket, you will see a portion of the seat.
- c. Insert the 3/4" dowel and, very gently, tap the seat until it drops out.
- d. Care must be taken with the seats. They are often a brittle material and are prone to breakage. **It is recommended that a new replacement seat be installed during reassembly.**

2C Inspection of Components

Thoroughly clean all parts. All components should be examined for wear and corrosion. Replace any parts that show visible wear.

The "O" rings and other elastomeric components should be replaced if they have been deformed or cut.

If seal components must be reused, carefully inspect for microscopic cracks and nicks. Scratches that might be ignored elsewhere can produce leakage if they are on seal carbons and seat wearing surfaces.

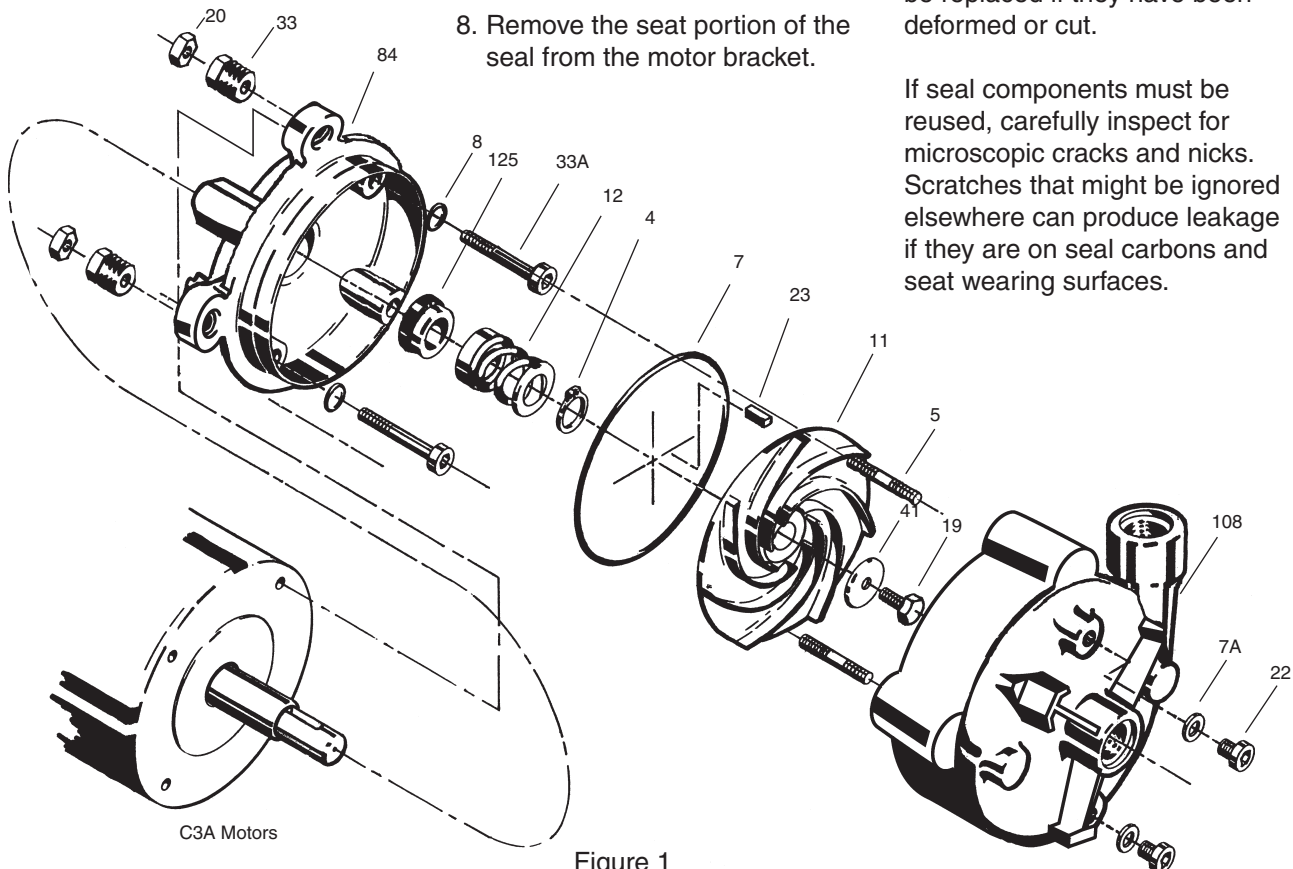
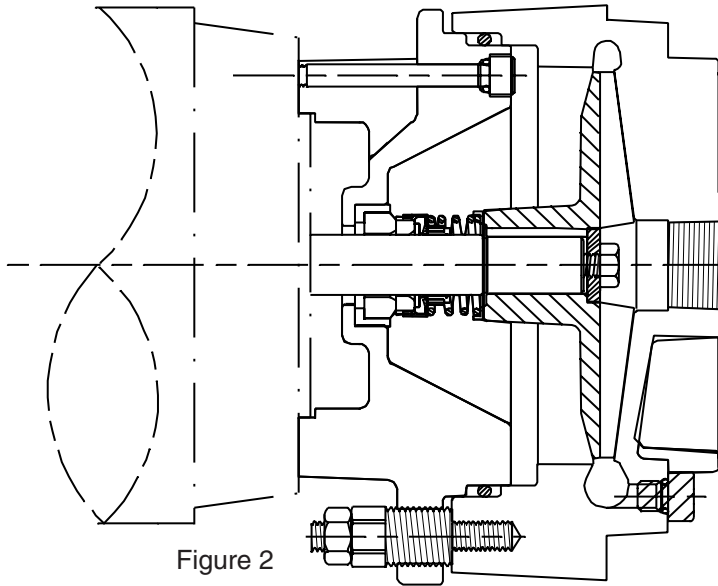

Figure 1

Service



C SERIES PUMPS

NAME / DESCRIPTION	KEY NO.	QTY
Motor Bracket	84	1
Casing	108	1
"O" Ring - Casing**	7	1
Impeller	11	1
Seal - Rotating Element**	12	1
Seal - Stationary Seat**	125	1
Stud - Casing	5	4
Jam Nut	20	4
Adjusting Screw	33	4
Socket Head Screw	33A	4
"O" Ring - Screw**	8	4
Snap Ring**	4	1
Drive Key**	23	1
Impeller Screw	19	1
Washer	41	1
Drain Plug (SAE)	22	1
"O" Ring - Drain**	7A	1

**Included in SKC4100, SKC5100, SKC6100 Mechanical Seal / O Ring Kits

Figure 2

Cleanliness is imperative when working with mechanical seals. Microscopic grit and particles between seal faces can be, and often are, the cause of early seal failures.

If the impeller can be rocked or wobbled on the shaft, it is too loose and must be replaced.

Check the shaft for galling, pitting, and corrosion. If the shaft is corroded where the seal elastomer comes in contact with it, the motor must be replaced. Surface corrosion must be removed so that seals can slide freely during assembly. The shaft diameter should be no smaller than .002" below the nominal fractional seal sizes. Remove any nicks or burrs which may have occurred during disassembly. Re-clean parts as necessary.

2D Reassembly

All parts should be visually inspected and cleaned or replaced as outlined in 2C above.

1. The seal seat (#125) must be installed in the motor bracket before the bracket is installed on the motor.

To install the seat:

- a. Place the motor bracket face up on a flat surface.
- b. Carefully press the seat, smooth side up, into the seat cavity of the motor bracket. To make the installation of the seat easier, apply a very thin coating of compatible seal lubricant to the elastomer portion of the seat prior to installation. Care must be taken not to damage the seat face. Thumb pressure is usually sufficient to install the seat. Make sure the seat is installed firmly and squarely and that it is then carefully cleaned.

2. Install the motor bracket (#84).

- a. This is best done with the motor standing on end.
- b. From the motor side: If removed during disassembly, thread the four (4) adjusting screws (#33) into the mounting flanges of the motor bracket until they are flush with the front faces of the flanges.

c. Slide the four (4) small "O"-rings (#8) fully onto the socket head screws (#33A).

d. Place the motor bracket (#84) on the motor. Slide the bracket back until the feet are resting against the motor face. The orientation of the motor bracket is not critical unless a flush line is used. In that case, align the flush line to meet system requirements.

e. Insert the four (4) socket head screws (#33A) into the motor bracket holes and thread into the motor face. Tighten securely using a 5 mm Allen wrench. Do not exceed 7 ft-lbs of torque or damage to the motor "C"-face may occur.

3. Install rotating element (#12).

a. Tip the pump assembly over into a horizontal position on the work area.

b. Lightly lubricate the motor shaft. Push the rotating element, spring, and then spring holder over the shaft.

Service

- c. Prepare the snap ring in the snap ring pliers and then compress and hold the seal spring slightly below the snap ring groove. Install the snap ring (#4). Make sure the snap ring is locked in the groove.
4. Install the impeller (#11).
 - a. Place the key (#23) in the shaft sleeve.
 - b. The impeller should slide on firmly, but easily, until it stops. Force should not be required to install the impeller in the correct position.
 - c. The impeller hub should be facing toward the motor.
 - d. Apply Loctite 277 to the threads on the screw (#19), then fasten the impeller using the washer (#41) and screw (#19). Tighten the screw securely (do not exceed 7 ft-lbs of torque), while holding the impeller stationary. **The impeller should not have any play or wobble.**
 5. Install the casing (#108).
 - a. Hand tighten four (4) studs (#5) into the casing until they are seated.
 - b. Lubricate and install the casing "O"-ring (#7) onto the first step in the motor bracket.
 - c. Place the casing over the motor bracket being careful not to pinch the "O"-ring. The casing discharge should be oriented to meet system requirements.
 - d. Loosely thread four (4) jam nuts (#20) onto the casing studs.
 6. Adjusting Impeller/Casing Clearance
 - a. Seat the casing down against the impeller with light hand pressure.
 - b. Turn the adjusting screws until they just touch the back face of the casing. The casing should not move during this adjustment. This will determine the zero clearance position. Set the minimum free running clearance as follows:
 - i. Viewing from the back of the motor bracket, (rear of motor) turn each adjusting screw clockwise exactly 30° (1/12 of a full revolution).
 - ii. Securely tighten the four (4) jam nuts against the adjusting nuts using a 9/16" wrench and a 5/8" wrench, being careful to prevent the adjusting nuts from turning.
 - c. Turn the impeller clockwise and listen for any scraping noises or interference. This may be done by turning the impeller screw with a 10 mm socket through the inlet port (Be careful not to loosen the screw), and listening through the discharge. If any contact is detected between the impeller and casing, perform the following steps:
 - i. Loosen the jam nuts, being careful not to turn the adjusting nuts.
 - ii. Repeat steps 6.b.i and 6.b.ii.
 - iii. Repeat step 6.c.

2E TESTING AND FINAL ADJUSTMENT

The pump is now ready for installation.

1. Reconnect the electrical connections referring to the colored or numbered tape used to mark the wires during disassembly.
2. Connect all piping and fill the pump with fluid.
3. Make sure all suction valves are opened and fluid will flow through the system. Discharge valve should be partially opened.
4. Start the pump and check for leaks on the pump and piping. Special attention should be given to the seal area at the rear opening in the motor bracket.
5. Using an amprobe or similar device, check for motor overload. If motor is overloading it is possible that the impeller clearance was not properly set as outlined in Step 6 outlined in "D" Reassembly.

C41 • C51 • C61 SERIES

3. **Parts and Repair Services**

- A. Parts
- B. Repair Service
- C. Warranty Service

6A Parts

Repair parts may be obtained through your local Authorized MTH Pumps Distributor who may be found in the yellow pages or by contacting:

MTH Pumps

401 W. Main St.

Plano, IL 60545

Phone: 630-552-4115

Fax: 630-552-3688

Email: Sales@MTHPumps.com

Web: WWW.MTHPumps.com

6B Repair Services

Repair service for an MTH pump should be obtained from the company through which it was purchased.

In the event this is not possible, the name and phone number of a nearby MTH representative or distributor may be obtained by contacting MTH Pumps. In the event that it is necessary to return the pump to the factory for repairs, remove all accessories attached to the pump. We cannot accept responsibility for their safe removal, storage, and return.

6C Warranty Service

All requests for warranty claims should be made through the company from which the pump was purchased or supplied. Complete details on what is wrong with the pump must be provided along with information on the system in which it is installed. Refer to the MTH Pumps Limited Warranty statement. Return authorization must be obtained prior to returning any equipment.

C41 • C51 • C61 SERIES

4. Limited Warranty

MTH makes good faith recommendations of Products, based on its experience and the application information provided by the Purchaser. However, the responsibility for testing and approving a Product to be used for a particular purpose lies with the Purchaser.

The obligations of MTH Tool Company, Inc. (hereinafter referred to as "MTH"), with respect to a "Product" (defined below) are limited as set forth herein.

ALL IMPLIED WARRANTIES, including the "implied warranty of merchantability" and the "implied warranty of fitness for a particular purpose" are HEREBY DISCLAIMED.

There are no warranties which extend beyond the description on the face hereof.

MTH warrants that, during the "Warranty Period" (defined below), the "Product" (defined below) will not fail to meet the "Operational Specifications" (defined below), within applicable industry tolerances established by the Hydraulic Institute, due to defects in its materials and workmanship. MTH does not warrant that any Product will meet the "Operational Specifications" in conditions other than the Standard Operating Conditions, unless agreed to by MTH in a signed writing.

For all purposes of this Limited Warranty:

- (a) The term "Warranty Period" shall mean the twelve (12) month period from the date of shipment from MTH to the Purchaser (the "Warranty Period").
- (b) The term "Product" shall mean: any item or assembly of items sold by MTH that are either manufactured or selected by MTH to meet the "Operational Specifications". The term "Product" does not include any item, assembly of items, or portion of such assembly that is selected or specified by any entity other than MTH, or that MTH has identified as ineligible for warranty coverage.
- (c) The term "Purchaser" shall mean the original person(s) or entity that issued the purchase order to MTH, for the Product.
- (d) The term "Operational Specifications" shall mean the specified dimensions, material composition, and performance parameters of a Product, as published by MTH, or as otherwise agreed in a signed writing between MTH and Purchaser. "Standard Operating Conditions", for pumps, shall mean: operating with clean water, at standard temperature and pressure. "Operational Specifications" shall not include visual appearance or any other parameters not expressly agreed to in writing.

If, within the Warranty Period, a Purchaser believes that a Product has failed to meet its Operational Specifications, the Purchaser must request a Return Goods Authorization ("RGA") in the manner specified at <http://www.mthpumps.com>, and supply any additional information MTH might reasonably request. If the Product was purchased through a distributor or any entity other than MTH, the RGA request must be made through that entity. Any Product returned without an RGA will be refused at the dock. Products authorized for return must be properly packaged to prevent further damage, clearly marked with the Return Goods Authorization "RGA" number provided by MTH, and shipped freight prepaid and allowed, F.O.B. the MTH factory at Plano, Illinois, USA.

MTH may, in its sole discretion, deny any warranty claim if shipping damage, any attempted disassembly, or any other action outside of MTH's control impairs MTH's determination of the existence of, or cause of a claimed failure.

Notwithstanding anything to the contrary in this Limited Warranty, MTH **shall have no obligation** to repair or replace any Product it determines to have any defects arising from or attributable to: (1) abrasion, corrosion, or erosion arising after shipment from MTH; (2) improper handling, packaging, installation, storage, or maintenance, after it is shipped by MTH; (3) repairs or alterations outside of MTH's factory, in any manner, without MTH's written authorization; (4) misuse, negligence, or accident after shipment from MTH; (5) use in a manner inconsistent with MTH's published instructions and Operational Specifications, or other written specifications agreed to by both Purchaser and MTH; or (6) incorrect power supply or power quality. MTH's determination with respect to the applicability of this Limited Warranty to any particular defect or Product shall be final and conclusive.

If, after examination by an authorized representative of MTH, MTH determines that the Product failed to meet the "Operational Specifications", within applicable industry tolerances established by the Hydraulic Institute, due to defects in its materials and workmanship, during the Warranty Period, then MTH will, at its option, ship a repaired or replaced Product to the Purchaser, F.O.B. MTH's factory in Plano, Illinois, U.S.A., freight prepaid and allowed. MTH will use a freight provider of its choosing, via a method no faster than that used for shipping the Product to MTH. MTH may, at its sole discretion, issue a credit memo to Purchaser for some or all Purchaser's shipping costs to return a defective Product to MTH.

MTH accepts no responsibility for costs associated with removal and reinstallation of Products.
Under no circumstances shall MTH be liable for incidental or consequential damages.

MTH neither assumes responsibility for, nor authorizes any person to assume for it, any other obligation in connection with the sale of any Product or any enlargement of this Limited Warranty.

Some States do not allow the exclusion or limitation of incidental or consequential damages. So, the above limitations or exclusions might not apply to you. This warranty gives you specific legal rights, and you might, also, have other rights, which vary from State to State.

By using this Product, you agree that this Limited Warranty is governed by the laws of the State of Illinois; that this Limited Warranty shall be interpreted and enforced only in accordance with the laws of the State of Illinois (excluding its conflicts of law provisions); and that you submit yourself to the jurisdiction of the 23rd Judicial Circuit, Kendall County, Illinois, which shall have exclusive jurisdiction over any controversy or dispute arising under or with regard to this Limited Warranty.



MTH PUMPS

401 West Main Street • Plano, IL 60545-1436
Phone: 630-552-4115 • Fax: 630-552-3688
Email: SALES@MTHPUMPS.COM
<http://WWW.MTHPUMPS.COM>

Order Online: www.PumpCatalog.com