

X Series Sealless Canned Regenerative Turbine Pumps



- Leak free Sealless design
- Canned stator motor
- Capacities to 22 GPM
- Heads to 450 feet
- Temperature range -40° to 130°C



MTH PUMPS

Sealless Canned Regenerative Turbine Pumps

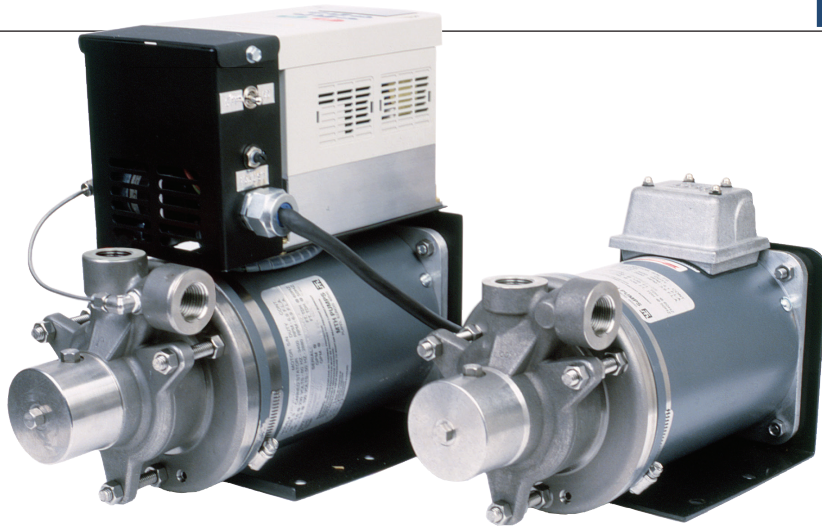

MTH X Series

The X41 Series line of sealless regenerative turbine pumps (also known as canned, hermetic, or zero emission pumps) is designed to handle applications with difficult to seal fluids where absolutely leak free performance is required, and mechanical seals simply cannot provide the needed reliability, protection, and performance. All of this is accomplished at a price point previously unseen in the industry, and is often comparable with other mechanically sealed solutions, but without the leaks and inevitable seal maintenance. Water/glycol mixtures and exotic heat transfer fluids present no difficulty for these units at fluid temperatures from -40°C up to 130°C. The canned motor design is far preferable to magnetic drive couplings as it does not add excessive length to the unit in tight OEM enclosures, or suffer from the magnetic de-coupling problems often associated with mag-drive solutions. Three bearings, high strength cast stainless steel components, and a sealless design assure extended

maintenance free life. To demonstrate the potential reliability of these units, well over 800 X41's have been shipped into the field from 1997 thru 2003 into water/glycol chiller applications. Of these 800+ units at end user sites, none have yet been reported to the factory as failed, leaking, or requiring any repair. For other special fluids and applications, optional elastomers, electrical connections, and variable frequency drive control packages are all available to custom fit your particular needs.

Leak Free Sealless design

The hermetically sealed pump/motor combination uses the process fluid itself for cooling, while a stainless steel barrier keeps the fluid isolated from the stator wire and rotor. A ceramic potting material is used to back up this .015 inch thick barrier to provide mechanical strength under high operating pressures. This special potting material is electrically insulating and also has the property of being highly heat conductive to

help dissipate excess heat. Each and every pump is tested for barrier and containment integrity before shipment.

Low NPSH Requirements

Like its T41 Series mechanically sealed counterpart, the X Series hydraulic passageways are designed to minimize thrust on the self-adjusting impeller to avoid upsetting its hydraulic balance, and to handle low NPSH conditions which can occur in some applications. New to the X Series is the location of the inlet and outlet on the centerline of the impeller to further eliminate the potential of axial imbalance that sometimes occurs during periods of marginal NPSH availability. With these design features, MTH has eliminated almost all of the bearing thrust loads in these units, and the motor thrust bearings exist only to provide axial rotor positioning. Vent/drain taps are provided on both ends of the pump/motor unit to facilitate draining or air purging of the unit in either the horizontal or vertical position. Proper air purging at startup will help assure that the bearings are properly lubricated and minimize startup wear and priming problems. SAE fittings are used for both of these openings to assure a reliable leak-free fit, and to minimize the potential of galling that can be troublesome if over-tightening should occur.

Compact Integrated design

The pump/motor units use three carbon bearings, with the motor rotor positioned between two thrust bearings, and the impeller supported on both sides to provide long running life. As with all plain bearing pumps, keeping pumping systems

STANDARD MATERIALS

PART	STANDARD STAINLESS STEEL	OPTIONAL MATERIALS
Casing	Stainless Steel AISI 316	Stainless Steel AISI 316
Motor Bracket	Stainless Steel AISI 316	Stainless Steel AISI 316
Impeller	W88 ASTM A494	Optional Impeller Materials are Available
Shaft	Stainless Steel AISI 304	Chrome Oxide Coated
"O" Rings	Viton A	EPR, Buna, Kalrez
Bearings	Carbon	Silicon Carbide

LIMITATIONS

Case Working Pressure	250 PSI
Differential Pressure (Min.)	25 PSI
Speed ¹	5400 RPM
Temperature	
Max Ambient	40°C
Potted Construction (Std.)	10°C to 130°C
Unpotted Construction ²	-40°C to 35°C

¹With Variable Speed Drive @ 90 HZ

²Special criteria required to meet or exceed these limitations. Please Consult Factory for further information. Pump, motor, and fluid must be at least 1°C or warmer whenever the unit is started to prevent frost from forming on the motor windings.

free of solids to prevent premature bearing failure is important. The X Series is, however, designed with easily replaceable bearings that can be changed out in a matter of minutes, providing a low cost means of maintaining "like new" performance over long periods. Specialized bearing materials are continuously being tested as new applications arise to allow further extension of useable life in harsh pumping applications. The rotor shaft bearings, as well as the turbine impeller, are easily replaced during scheduled maintenance events when used under severe operating conditions.

Installation Features

All models feature top centerline suction and side discharge for best inlet conditions. The entire unit can be rotated every 90° to allow different inlet/outlet positions while maintaining best fluid entry, particularly when suction pressures are approaching the vapor pressure of the pumped fluid. There are no orientation restrictions when installing these pumps. Vertical mounting (pump up or down) has no effect on the unit's operation. This ability to mount the pump in any position gives the customer added flexibility in the design of their system. Compactness also favors these canned motor pumps over magnetic drive pumps. In fact, most models are no larger than their equivalent close-coupled mechanically sealed pump/ODP motor cousins.

Optional Pipe Threading

Optional inlet/outlet threading is available to match your system design needs. SAE threads are standard where the most highly reliable leak-free connections are required. NPT threads are available for North American usage for compatibility with low cost, commonly available pipe fittings. BSP is available for use with commonly available pipe fittings in England and associated countries, while ISO is used for applications where compatibility with international standards is important. SAE threads are also available for use where the most highly reliable leak-free connections are required.

Design Features

The hermetically sealed pump/motor combination uses the process fluid itself for cooling, while a stainless steel barrier keeps the fluid isolated from the stator wire and rotor. A ceramic potting material is used to back up this .015 inch thick barrier to provide mechanical strength under high operating pressures. This special potting material is electrically insulating and also has the property of being highly heat conductive to help dissipate excess heat. Each and every pump is tested for barrier and containment integrity before shipment.

The pump/motor units use three carbon bearings, with the motor rotor positioned between two thrust bearings, and the impeller supported

on both sides to provide long running life. As with all plain bearing pumps, keeping pumping systems free of solids to prevent premature bearing failure is important. The X Series is, however, designed with easily replaceable bearings that can be changed out in a matter of minutes, providing a low cost means of maintaining "like new" performance over long periods. Specialized bearing materials are continuously being tested as new applications arise to allow further extension of useable life in harsh pumping applications. The rotor shaft bearings, as well as the turbine impeller, are easily replaced during scheduled maintenance events when used under severe operating conditions.

Like its T41 Series mechanically sealed counterpart, the X Series hydraulic passageways are designed to minimize thrust on the self-adjusting impeller to avoid upsetting its hydraulic balance, and to handle low NPSH conditions which can occur in some applications. New to the X Series is the location of the inlet and outlet on the centerline of the impeller to further eliminate the potential of axial imbalance that sometimes occurs during periods of marginal NPSH availability. With these design features, MTH has eliminated almost all of the bearing thrust loads in these units, and the motor thrust bearings exist only to provide axial rotor positioning.

Vent/drain taps are provided on

Variable Speed Option



Most MTH pump products are available with an optional variable frequency controller and a pressure transducer in a completely assembled and tested unit. A closed loop pressure transducer / variable frequency drive combination can eliminate the need for costly pressure relief valves and their associated plumbing problems, while gaining the ability to maintain constant discharge pressure by automatically varying pump motor speed. Signal inputs and outputs are available on the drive for accommodating a variety of external controls, alarm set point signals, and other programmed outputs.

This package is particularly helpful to OEM manufacturers whose

equipment is exported to countries utilizing 50-Hertz electrical supply systems. The drive can take inputs at 50 or 60Hz at a number of different voltages, and produce a variable frequency and voltage output suitable for pump output requirements, without any rewiring or user intervention required. This is a significant step forward in the design of a truly power source independent, worldwide product. Variable frequency controller / transducer packages are also available for customer applications where flow, temperature, or other variables need to be maintained. Please consult the factory for further information on these options.

both ends of the pump/motor unit to facilitate draining or air purging of the unit in either the horizontal or vertical position. Proper air purging at startup will help assure that the bearings are properly lubricated and minimize startup wear and priming problems. SAE fittings are used for both of these openings to assure a reliable leak-free fit, and to minimize the potential of galling that can be troublesome if over-tightening should occur.

All models feature top centerline suction and side discharge for best inlet conditions. The entire unit can be rotated every 90° to allow different inlet/outlet positions while maintaining best fluid entry, particularly when suction pressures are approaching the vapor pressure of the pumped fluid. There are no orientation restrictions when installing these pumps. Vertical mounting (pump up or down) has no effect on the unit's operation. This ability to mount the pump in any position gives the customer added flexibility in the design of their system.

Compactness also favors these canned motor pumps over magnetic drive pumps. In fact, most models are no larger than their equivalent close-coupled mechanically sealed pump/ODP motor cousins.

Advantages

X SERIES Testing

Like other MTH products, 100% of X Series pumps are tested for proper operating characteristics before shipment. For specially requested longer term testing, a facility is available to simulate actual customer applications. MTH can operate a pump under the customer specified conditions for periods of time necessary to extrapolate minimum service life, recommended service intervals, MTBF, or other information. Testing quotations and proposals are based on the complexity of the required test, and with any special fluids being supplied by the customer.

The X Series should be considered for applications where leakage cannot be tolerated. The sealless design ends down time and maintenance problems associated with mechanical seal pumps.

The compact size fits most OEM situations where close-coupled ODP motor/pumps will fit. These pumps can be easily mounted vertically, with the pump end up using the motor end cap as the base, or horizontally, using a standard or special mounting bracket, as necessary, to fit each application.

The X Series has fewer parts than most pump/motor combinations, which translates into easy assembly/disassembly for maintenance, and for lower manufacturing costs which ultimately means a lower price to the customer.

All rotating parts are enclosed, reducing ambient noise. No fans or ball bearings, which are typically sources of noise, are used. These pumps are exceptionally quiet due not only to their "plain bearing" design, but also because of refinements in the water passage hydraulics. This essentially eliminates

the "high pitched whine" that has previously been associated with regenerative turbine pumps.

The sealless canned motor design offers significant advantages over magnetic drive solutions. The X Series pumps are actually integrated into the motor housing to provide a very compact package that eliminates the excess space requirement for a coupling, which is often critical in tight OEM enclosures. This design is also more reliable in that it has fewer parts and does not suffer from the magnetic de-coupling problems or degradation that often occur without warning in mag-drive units.

Motors

The selected motor insulation allows operation in high temperature applications. Windings are suitable for operation at temperatures of 200°C (392°F) and utilize NEMA Class N inverter grade insulation for use with variable frequency drives and to provide the longest life under all operating conditions.



X SERIES

Design Features

- Extremely Long Service Life
- Leak Free Sealless Design
- Canned Stator Motor
- Capacities to 22 GPM
- Heads to 450 Feet
- Low NPSH Requirements
- Temperature Range -40°C to 130°C
- Compact Integrated Design
- Stainless Steel Wetted Parts for Excellent Chemical Compatibility
- Standard NPT Threads with optional SAE, BSP, and ISO Available
- Conduit or Electrical Junction Box
- Variable Frequency Drive / Transducer Package Optional

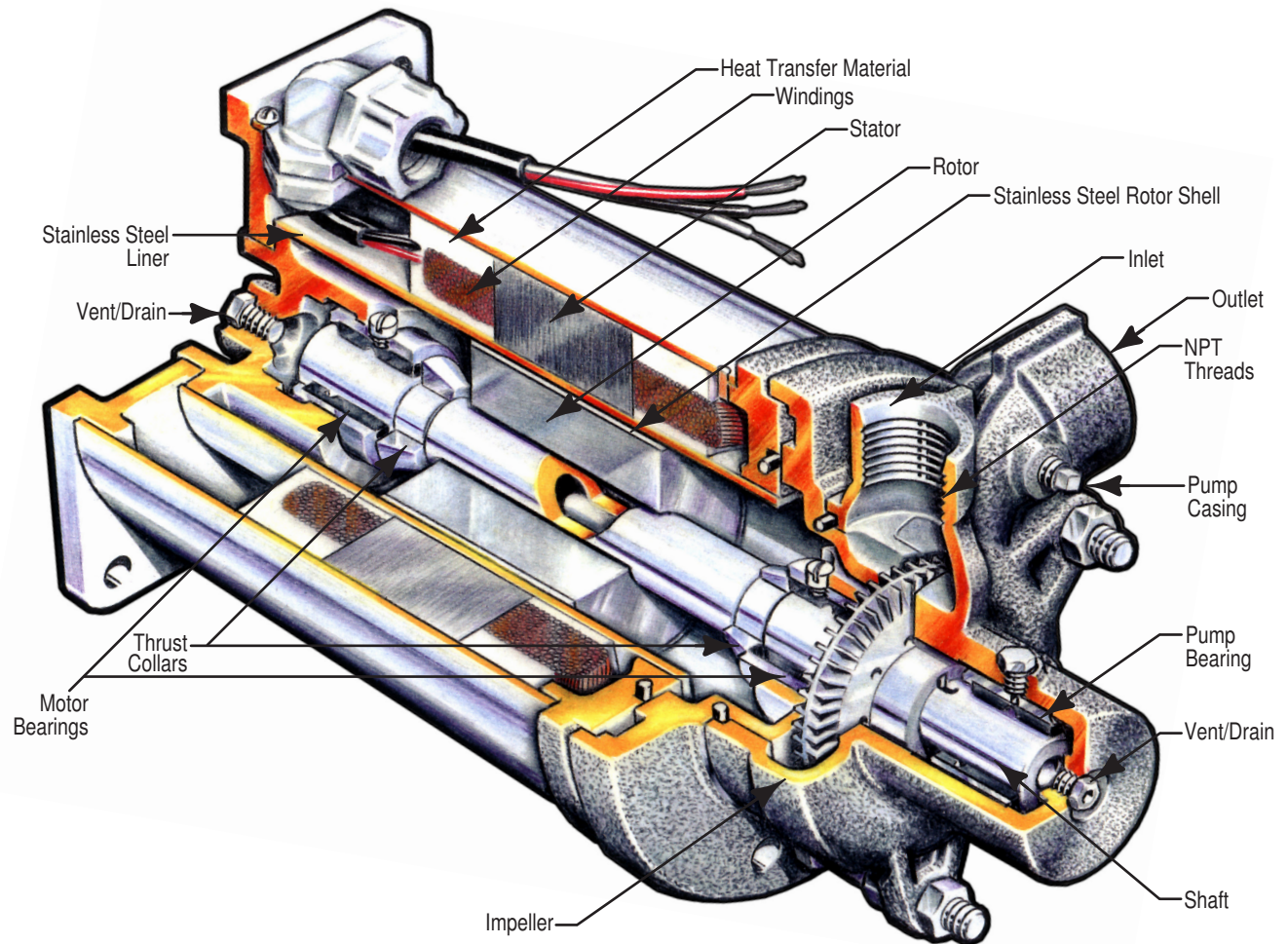

Performance Curve

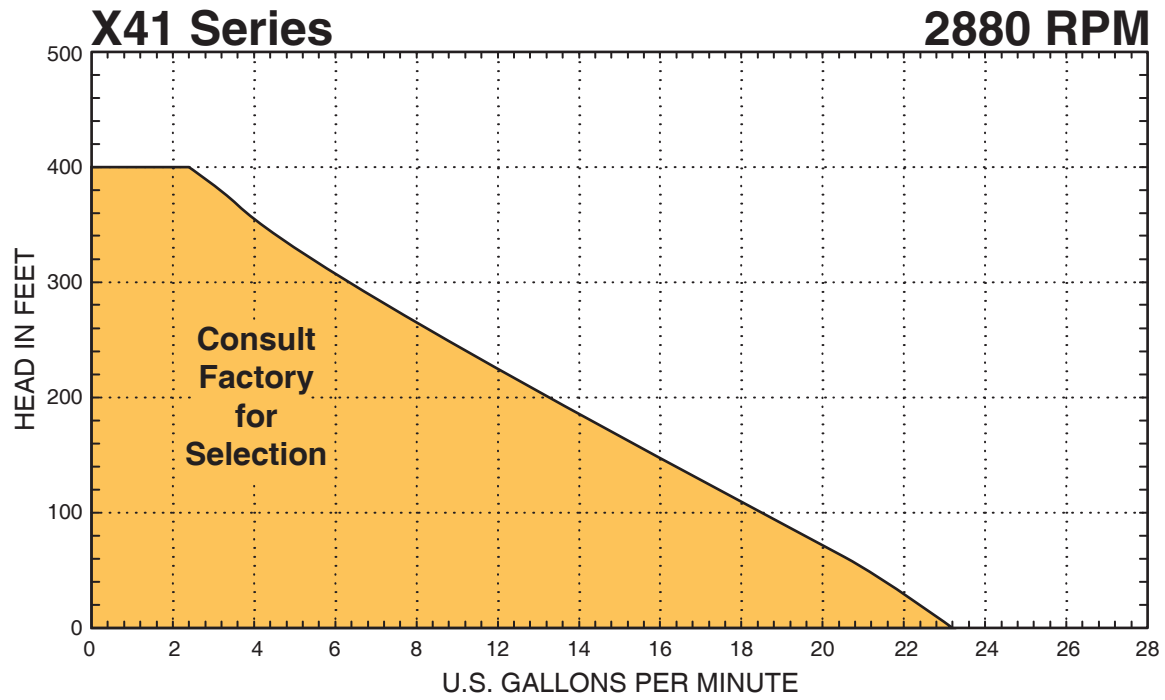
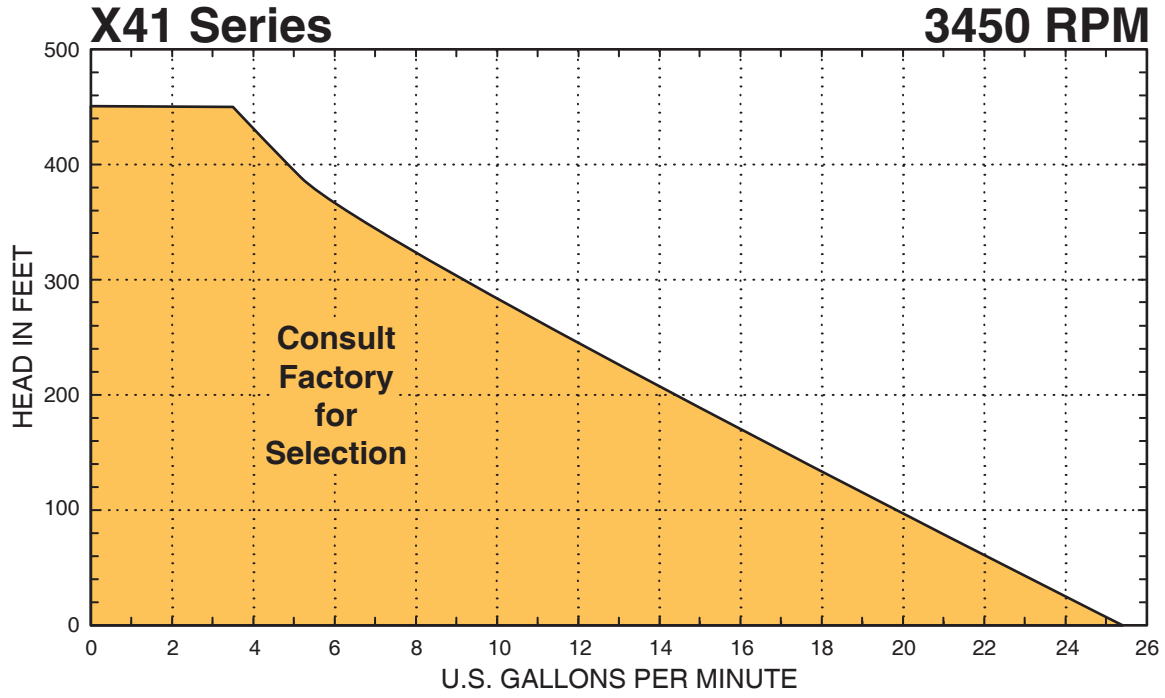

Dimensions

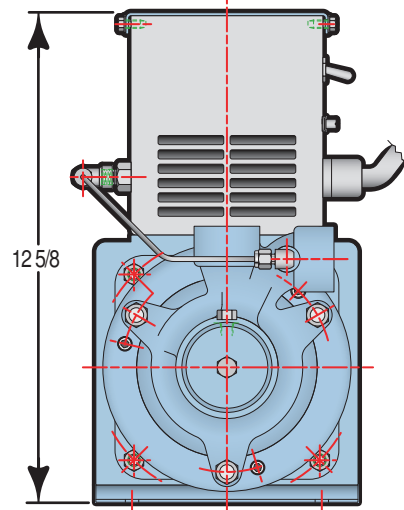
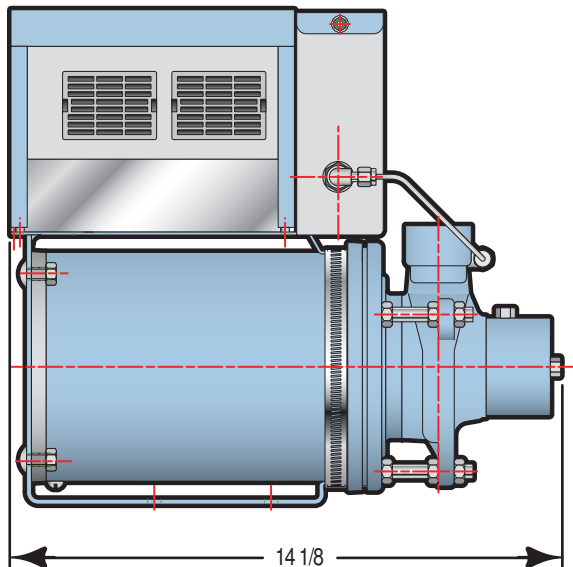
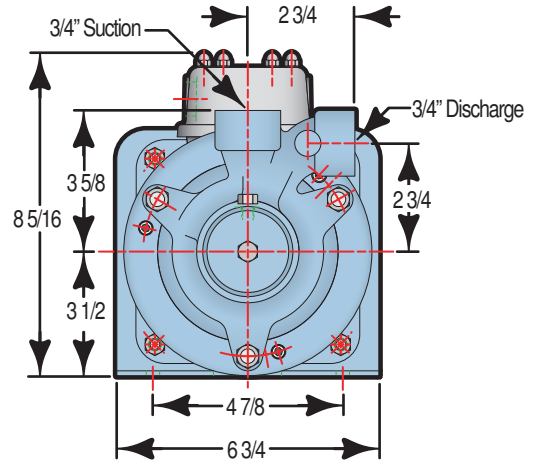
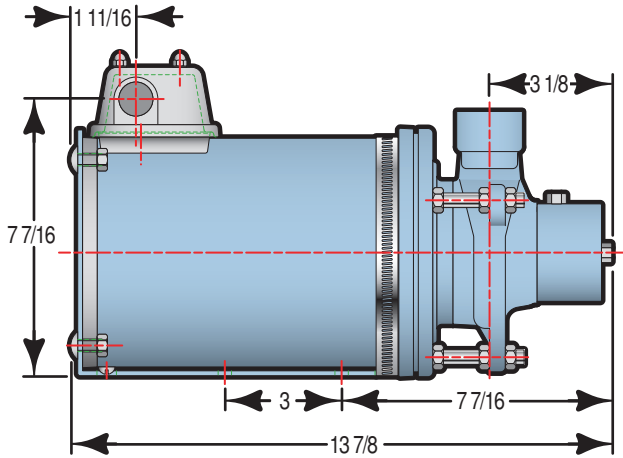

Application Specifications

Type of Service _____
 Fluid Name _____
 Suction Pressure _____ Feet of Fluid Head
 Maximum Flow _____ GPM
 @ _____ Feet Total Dynamic Head
 Minimum Flow _____ GPM
 @ _____ Feet Total Dynamic Head
 Typical Flow _____ GPM
 @ _____ Feet Total Dynamic Head
 Maximum Fluid Temperature _____ °C, °F
 Minimum Fluid Temperature _____ °C, °F
 Typical Operating Fluid Temperature _____ °C, °F
 Net Positive Suction Head Available _____ Feet
 Fluid Head Vapor Pressure _____ Feet
 at Max. Fluid Temp.

Surface Tension _____ Dynes per Sq. Centimeter at
 Maximum Temp.
 Viscosity of fluid _____ at Typical Operating Temp.
 (Centipoise)
 Specific Gravity of Fluid _____ at Typical Operating Temp.
 Known Compatible Construction Materials _____
 Known Compatible Elastomers for Static Use _____
 Known Non-Compatible Elastomers _____
 Duty Cycle _____ Starts/Hour, Day, or Continuous
 Duty Cycle _____ Hours per Day
 Available Voltage _____ (115/208-230/460)
 Phase _____ (1 or 3)
 Input Frequency _____ (50 or 60 Hertz)
 Maximum Current Available _____ Amps.
 (Starter or Contactor)

Order Online: www.PumpCatalog.com



MTH PUMPS

401 West Main Street • Plano, IL 60545-1436
Phone: 630-552-4115 • Fax: 630-552-3688
Email: SALES@MTHPUMPS.COM
<http://WWW.MTHPUMPS.COM>