

BRONZE PEDESTAL RUBBER IMPELLER PUMPS

RUBBER IMPELLER PUMPS SERIES N200M PERFORMANCE

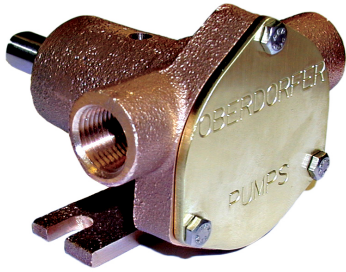

FEATURES

- Bronze Construction
- 3/8" Suction and Discharge Ports
- Mechanical Carbon Ring, Ceramic Face Main Pump Seal Standard, Optional Nitrile Lip Seal
- Two Sealed Ball Bearings Spaced for Maximum Load Ability
- Drain Openings Separate Seal & Bearing Areas
- Neoprene Impeller Standard
- Stainless Steel Shaft
- Machined-in Cam

DRIVE

Either direct drive with flexible coupling or pulley drive can be used. Make sure both flexible coupling halves are properly aligned. When using pulley, do not over tighten belt.

LIQUIDS AND TEMPERATURE

Liquids compatible with neoprene can be pumped including fresh and salt water solutions and mild chemicals. Do not pump severe solvents or acids. When possible, flush pump with fresh water after each usage. Extremes of cold and heat will affect impeller life. Limits of 40° to 140° F should be observed. Do not allow liquid in pump to freeze. Drain pump by loosening cover screws. Use methyl alcohol based anti-freeze compounds.

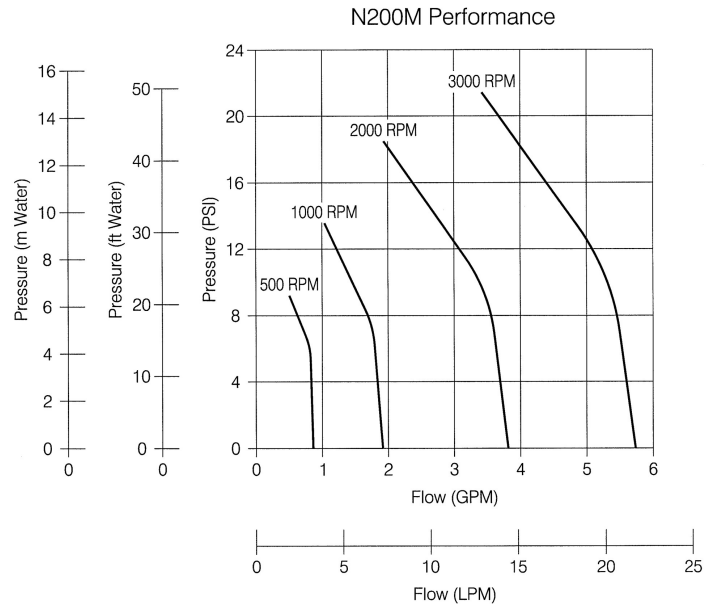

SUCTION LIFT

Suction lift of 15 feet is possible when impeller is wet. Suction lines must be air tight in order for pump to self prime. A foot valve at beginning of suction line is recommended.

EXPLODED VIEW AND PARTS LIST

MODEL N200M

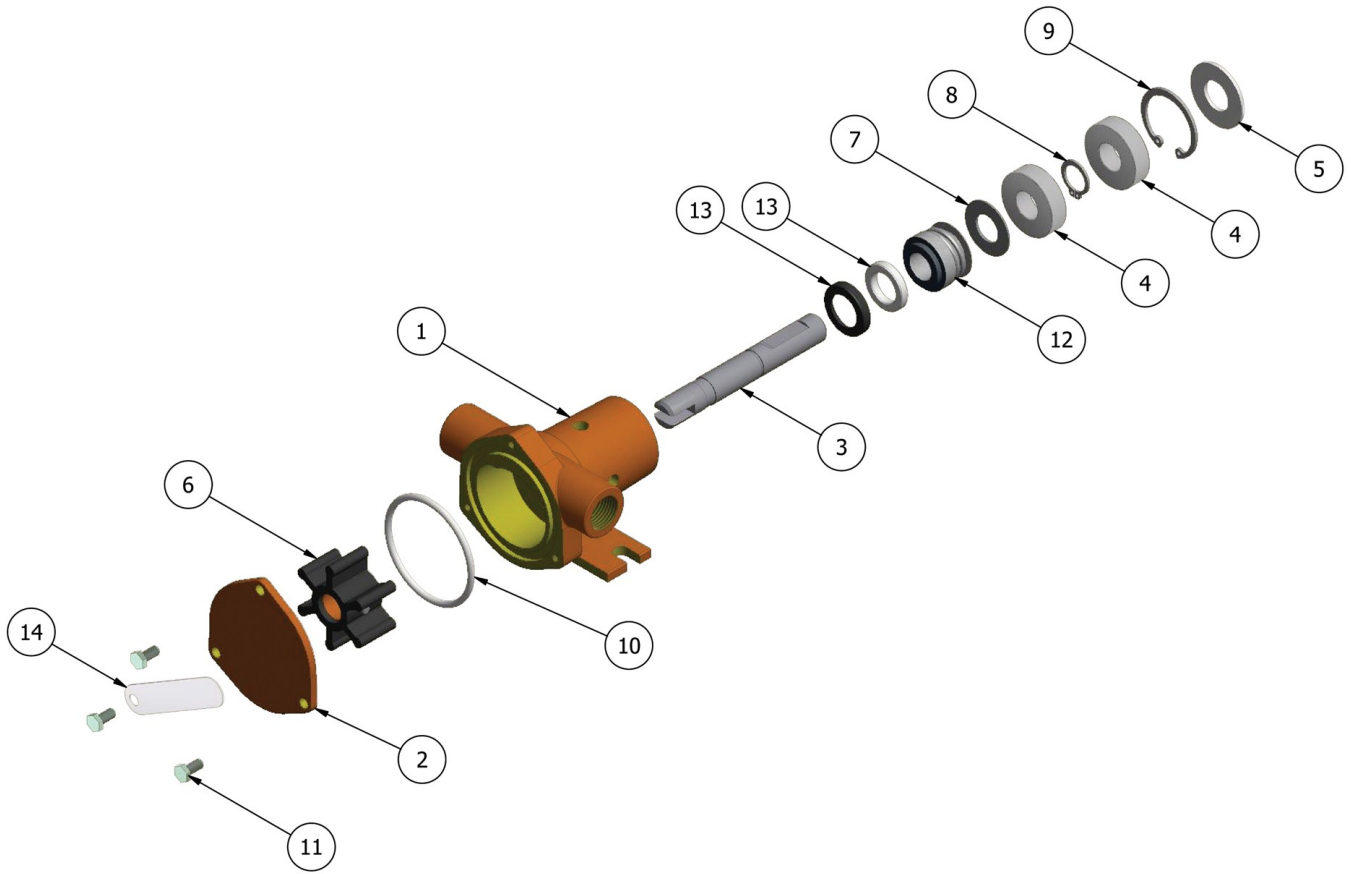

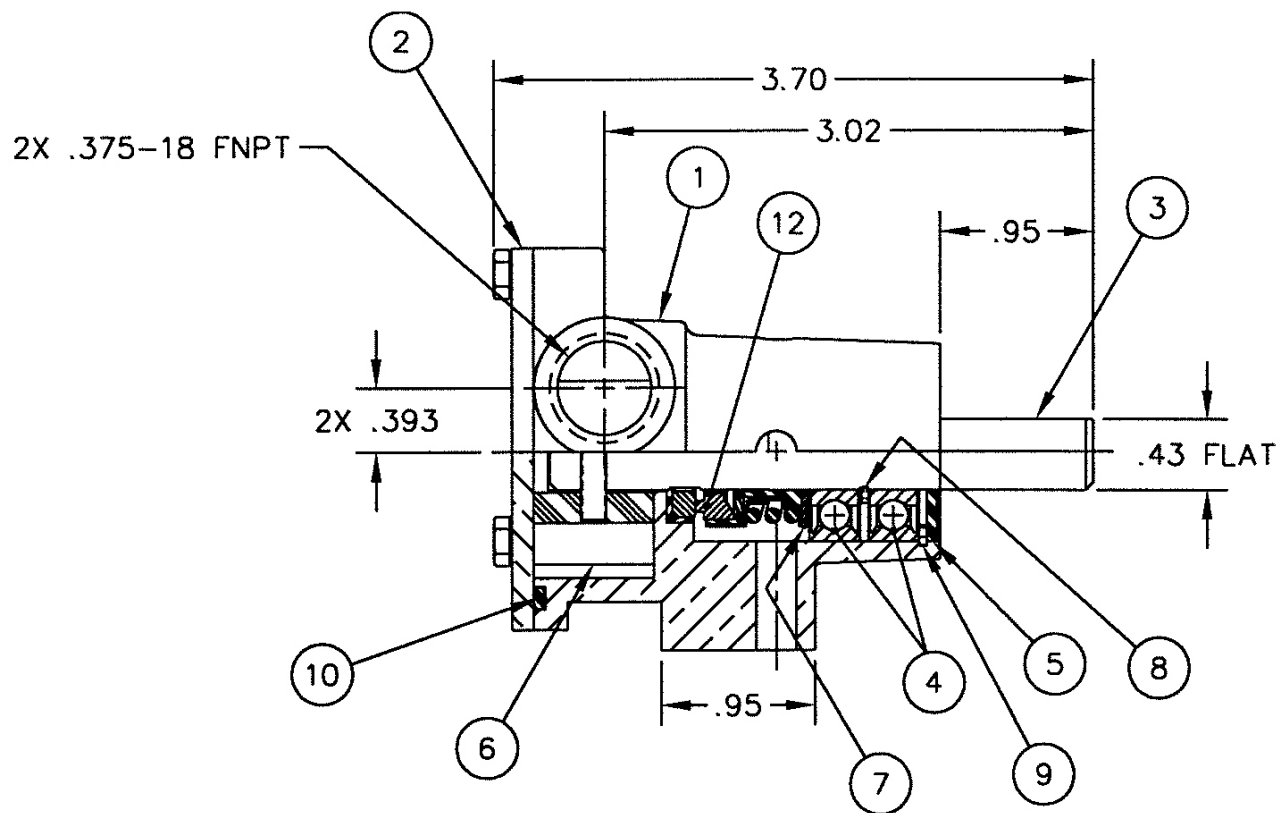

SECTION X-X

*ITEMS INCLUDED IN REPAIR KIT P/N 12310			
*12	1	33212	MECH SEAL ASSY
11	3	2391	SCREW, M4x0.7-6g
*10	1	2390-134	O-RING, BUNA
9	1	2389	RET. RING, INT, 28mm
8	1	2388	RET. RING, 12mm
7	1	2383	WASHER, RAISED
*6	1	2379	IMPELLER
5	1	2378	DUST SHIELD
4	2	2376	BALL BEARING
3	1	2375	SHAFT
2	1	2374	COVER
1	1	2373	BODY
ITEM	QTY	PART NO	DESCRIPTION
PARTS LIST			

DIMENSIONS

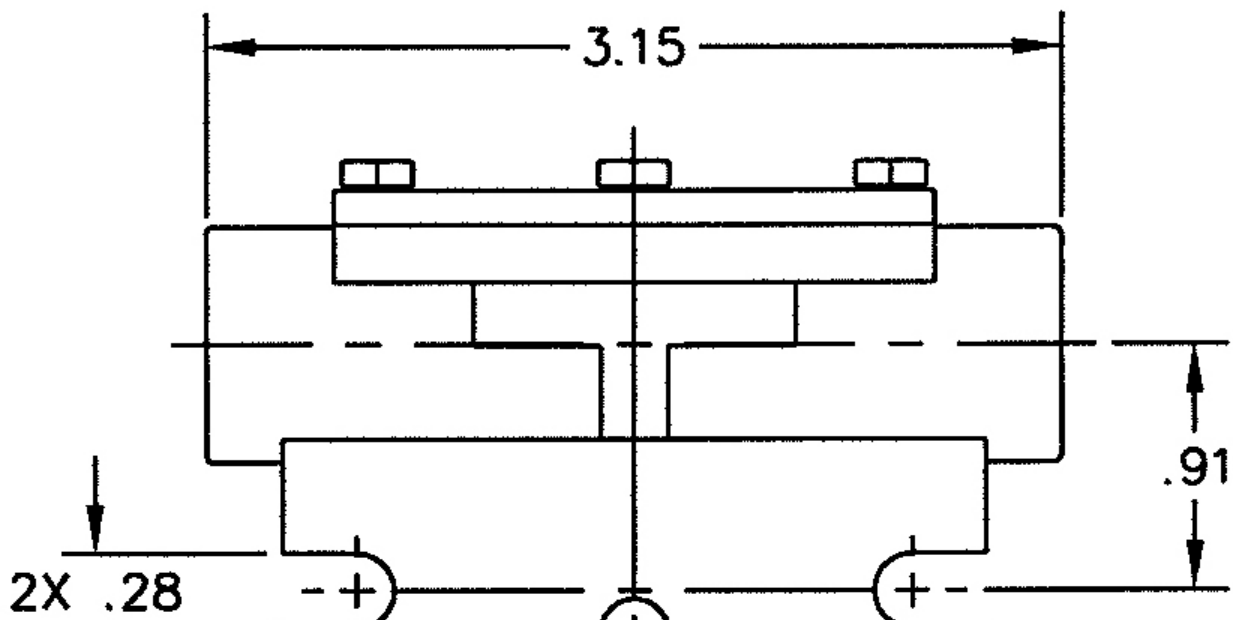
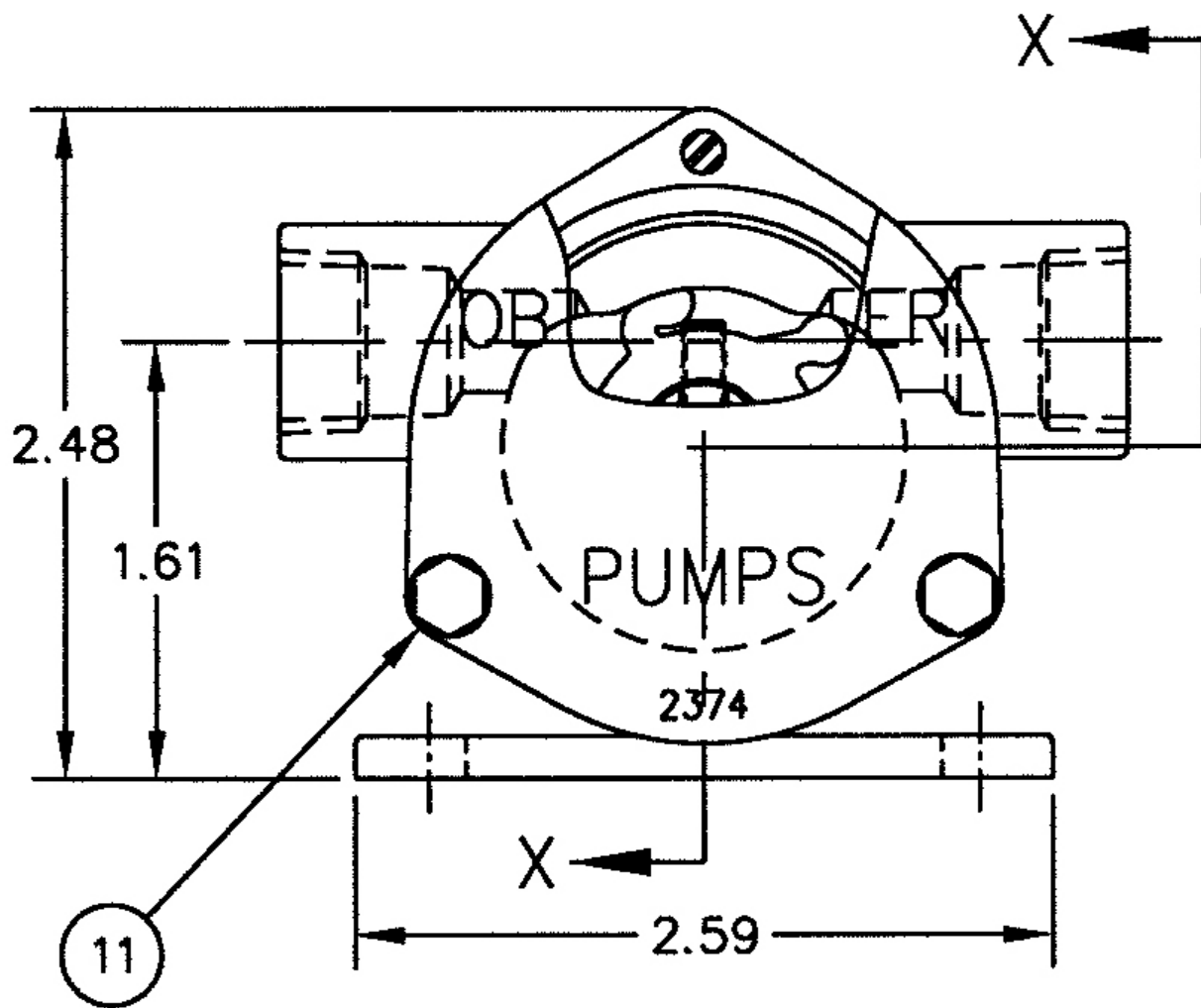

ROTATION

Direction of shaft rotation determines inlet and outlet ports (see line drawing).

IMPELLER REPLACEMENT

The impeller must be replaced if it is worn out or has been damaged by debris or by running the pump dry. Symptoms of a defective impeller are low pumping pressure and low flow causing overheating of the engine. Poor pump performance can also be caused by slippage of V-belts, so belts should be checked for tightness. To replace the impeller remove screws and cover. Pull out the impeller with nose pliers or two screwdrivers. Be careful not to dent the pumping chamber with these tools. When inserting new impeller, line pin in impeller with the slot in the shaft. Use oil on shaft and avoid forcing the impeller onto the shaft. The impeller should also be removed for storage periods to prevent the blades from taking a permanent set.

SEAL REPLACEMENT

If water drips from the weep hole or from the area where the shaft exits the pump, the seal is defective and must be replaced. Prolonged running of the pump with a leaky seal can destroy the ball bearings resulting in catastrophic pump failure and engine shut-down. For seal replacement, the pump must be removed from the engine and disassembled in order to gain access to the seal area. Where mechanical seals are used, both components (stationary and rotating member) must be replaced at the same time.

MOUNTING

Pump will operate satisfactorily when mounted in any position. **DO NOT RUN DRY.** Rubber impeller pumps generate high rubbing friction unless lubricated by liquid pumped. Lack of liquid will cause impeller to burn up.