

EXPLODED VIEW & PARTS LISTING

Model: G50AS11
Model#: 855334

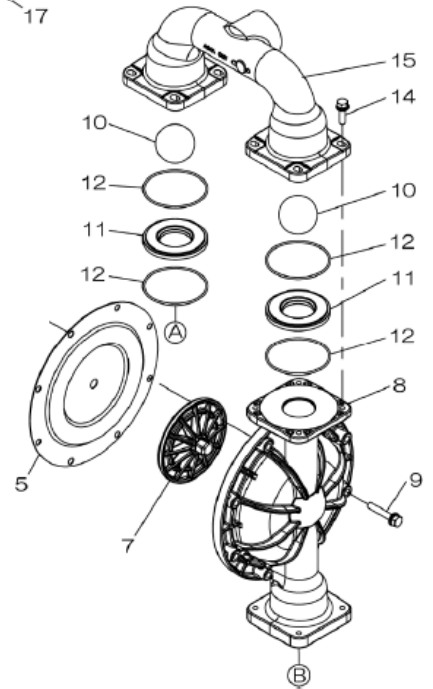

Air Operated Double Diaphragm Pump

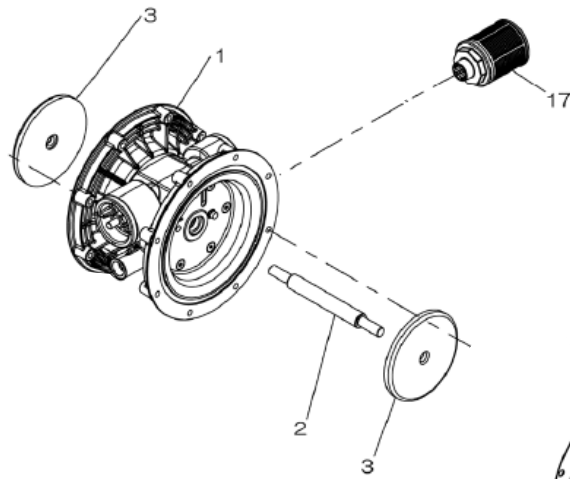
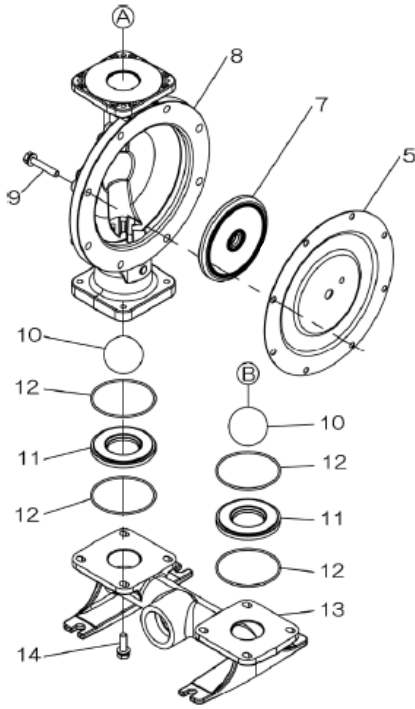

EXPLODED VIEW & PARTS LISTING

Air Operated Double Diaphragm Pump

Model: G50AS11

Model#: 855334

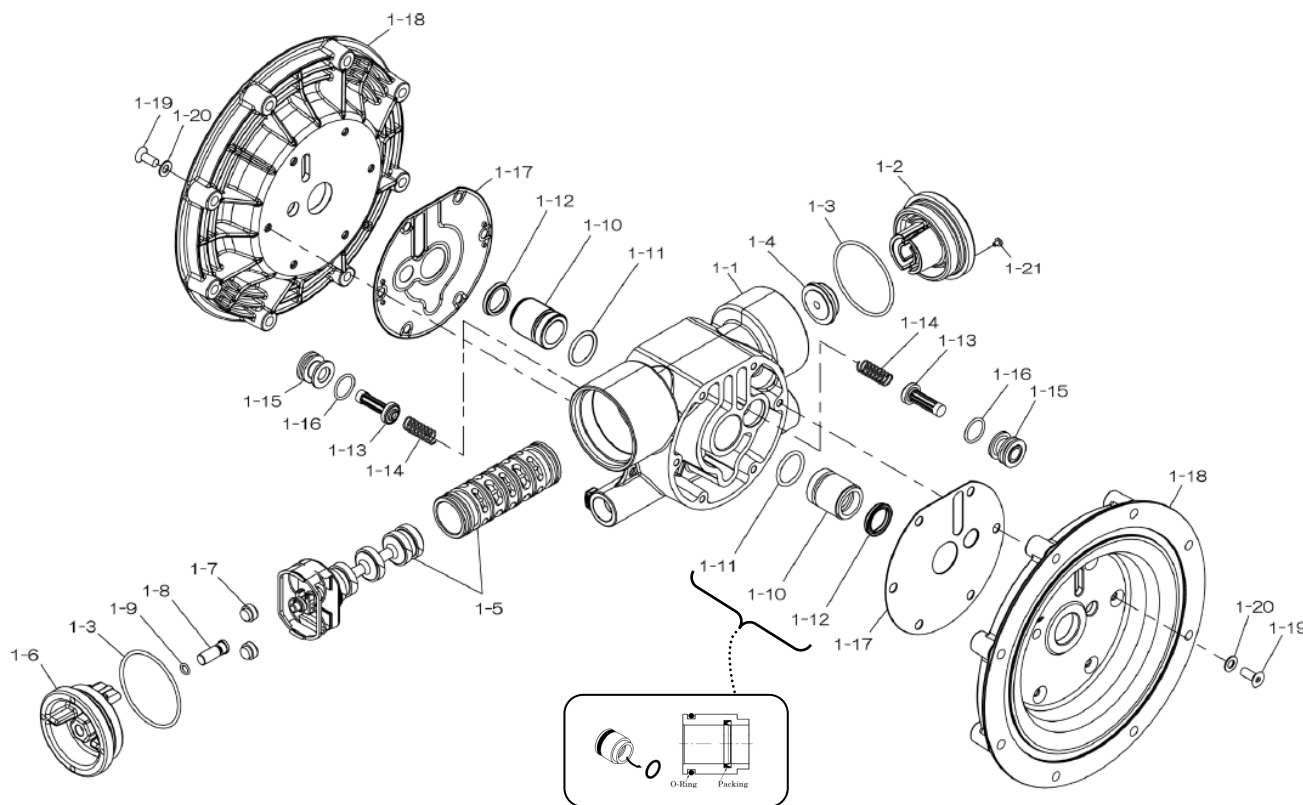

Air Operated Double Diaphragm Pump

Ref#	Part No.	Description	QTY.
1	805361	BODY ASSY	1
1-1	717393	BODY	1
1-2	717395	CAP B	1
1-3	640140	O RING	2
1-4	773491	CUSHION	1
1-5	805063	C SPOOL ASSY	1
1-6	717394	CAP A	1
1-7	684128	CUSHION	2
1-8	712976	RESET BUTTON	1
1-9	640005	O RING	1
1-10	780325	THROAT BEARING	2
1-11	640029	O RING	2
1-12	685444	PACKING	2
1-13	780333	PILOT VALVE ASSY	2
1-14	711937	SPRING	2
1-15	771740	VALVE SEAT	2
1-16	640020	O RING	2
1-17	773485	GASKET	2
1-18	717392	AIR CHAMBER	2
1-19	683812	BOLT	12
1-20	684987	WASHER	12
1-21	686486	SCREW	1
2	717398	CENTER ROD	1
3	581154	CENTER DISK B	2
5	773482	DIAPHRAGM	2
7	717396	CENTER DISK A	2
8	717391	OUT CHAMBER	2
9	687233	BOLT & WASHER	16
10	773173	BALL	4
11	717399	VALVE SEAT	4
12	687220	O-RING	8
13	717442	IN MANIFOLD	1
14	682725	BOLT & WASHER	16
15	717425	OUT MANIFOLD	1
17	804764	MUFFLER	1
KIT	KG-50MS	LIQUID KIT	
KIT	KG-50AM	AIR MOTOR KIT	

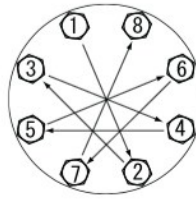

[CLICK HERE FOR TORQUE](#)



General Tools:

- Socket Wrenches: 17mm, 24mm
- Hexagonal Box Wrench: 5mm
- Small Crowbars
- Open-End Wrenches: 17mm, 24mm
- Plastic Hammer

Special Tools:

- Sleeve Remover (713180) (Sold Separately)

Miscellaneous:

- Nuts: 2 (M16x1.5)
- Thread Locker
- Urea Grease Grade (NLGI) No. 2 for Center Rod (Ref# 2)

[CLICK HERE FOR MAINTENANCE MANUAL](#)

Customer Notes

Model #: _____

Description: _____

Serial #: _____

Date Installed: _____

Department Location: _____

Tag/Project: _____