

EXPLODED VIEW & PARTS LISTING

Model: NDP-80BST-FDA  
Model #: 852651-FDA

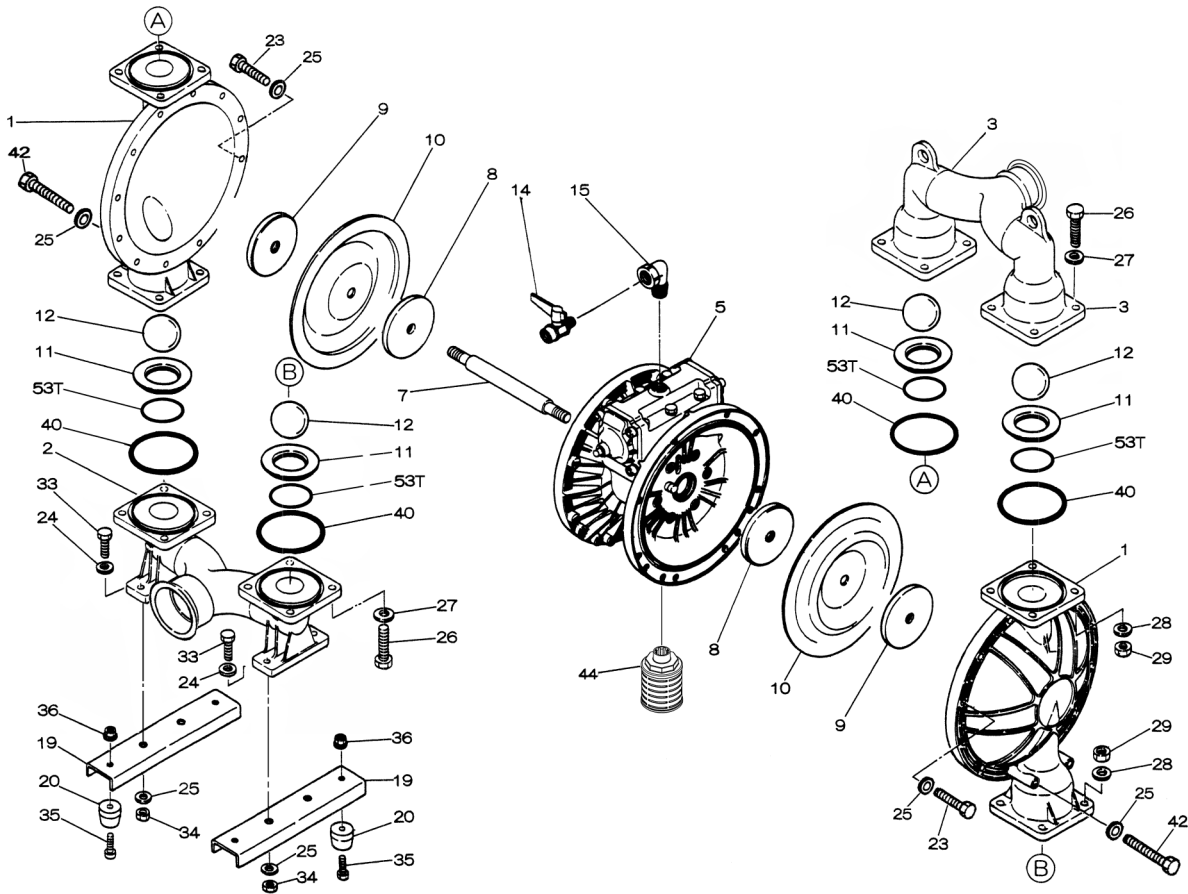

Air Operated Double Diaphragm Pump



Air Operated Double Diaphragm Pump

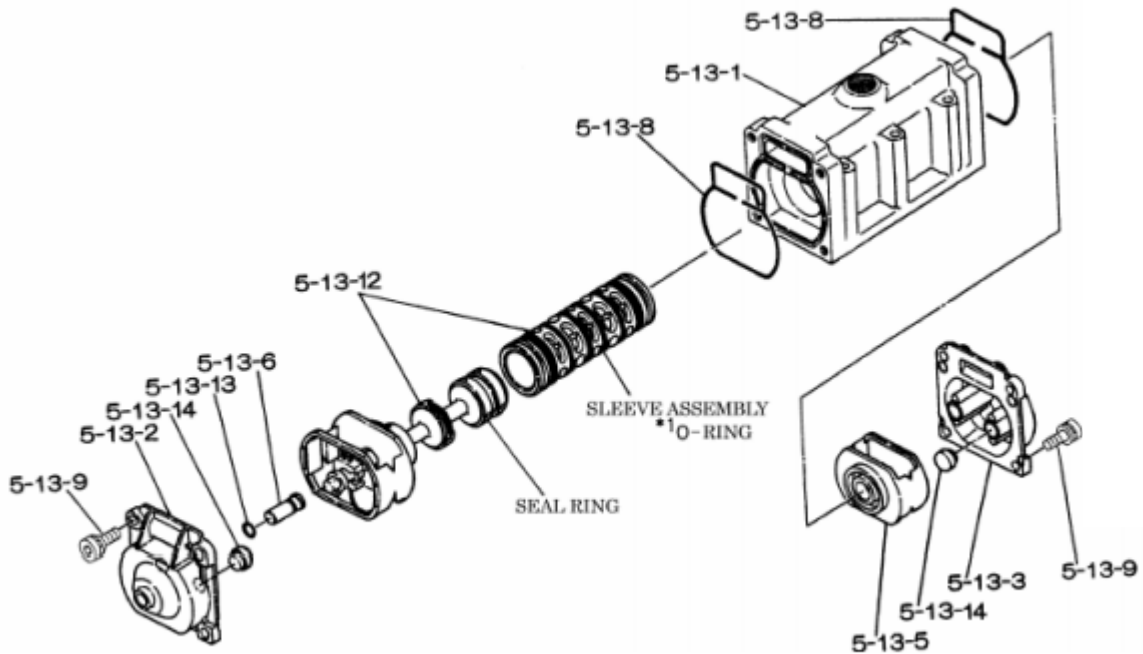
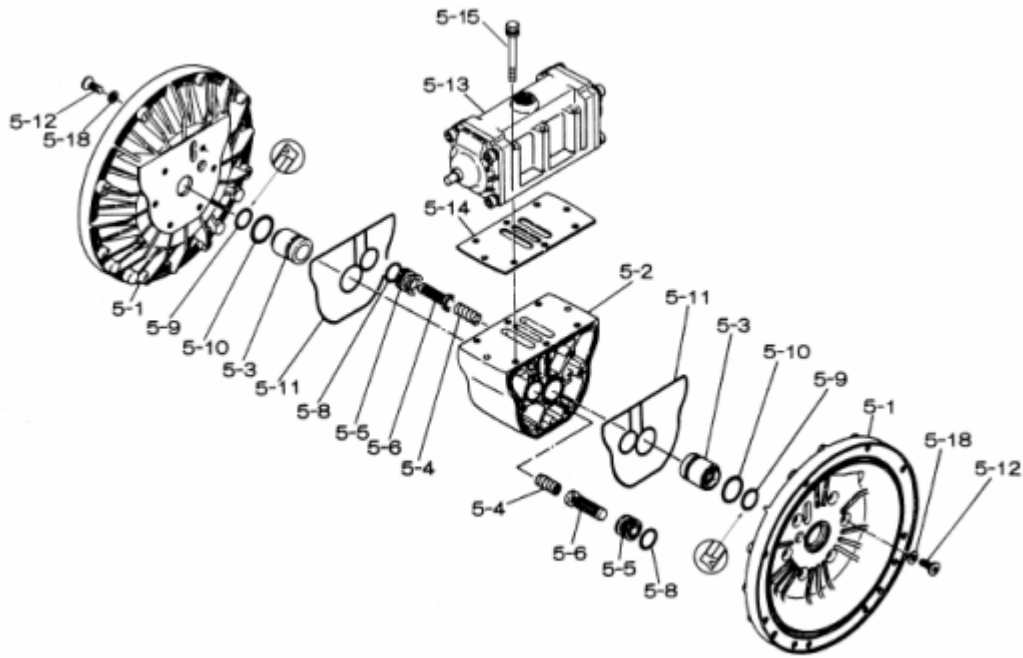

Air Operated Double Diaphragm Pump

REF. No.	PART No.	DESCRIPTION	QTY.	REORDER
1	712933-EP	Out Chamber	2	
2	712605-TC-EP	In Manifold - NPT	1	
3	712604-TC-EP	Out Manifold - NPT	1	
5	803113-XP	Body Assembly	1	
5-1	711935-XP	Air Chamber	2	
5-2	711936-XP	Body	1	
5-3	772689	Throat Bearing	2	
5-4	711937	Spring	2	
5-5	771740	Pilot Valve Seat	2	
5-6	832163	Pilot Valve Assembly	2	
5-8	640020	O-ring	2	
5-9	685444	Packing	2	
5-10	640029	O-ring	2	
5-11	771742	Gasket	2	
5-12	683812-S	Flat Head Bolt	12	
5-13	802971-XP	Valve Body Assembly	1	
5-13-1	711931-XP	Valve Body	1	
5-13-2	580999-XP	Cap A	1	
5-13-3	581000-XP	Cap B	1	
5-13-5	771735	Spring Stopper	1	
5-13-6	712976-S	Reset Button	1	
5-13-8	771738	Gasket	2	
5-13-9	685036	Bolt	8	
5-13-12	805084	C Spool Valve Assy.	1	
5-13-12 *1 Sleeve	803675	Sleeve Assembly	1	
5-13-13	640005	O-ring	1	
5-13-14	684128	Cushion	4	
5-14	771712	Gasket	1	
5-15	684240-S	Bolt	6	
5-18	684987	Plain Washer	12	
7	711940	Center Rod	1	
8	711041	Center Disk	2	
9	711039-EP	Center Disk	2	
10	770934	Diaphragm	2	
11	711910-EP	Valve Seat	4	
12	770694	Ball	4	
14	684322	Ball Valve	1	
15	682523	Elbow	1	
19	711912-XP	Pump Base	2	
20	771402	Cushion	4	
23	621182	Bolt	20	
24	631174	Plain Washer	4	
25	631937	Wave Washer	28	
26	621203	Bolt	16	
27	631175	Plain Washer	16	
28	631938	Wave Washer	16	
29	628014	Nut	16	
33	621177	Bolt	4	
34	628013	Nut	4	
35	621149	Bolt	4	
36	682276	Nut with Flange	4	
40	643078	O-ring	4	
41	643015	O-ring	4	
42	683543	Bolt	4	
44	804764	Silencer	1	
53	643145	O-ring	4	
KIT	K80-MH-FDA	LIQUID END KIT		
KIT	K80-AM	AIR MOTOR KIT		

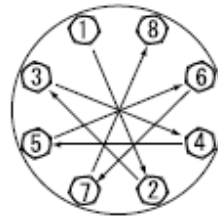

**Tightening torque for center rod and out chambers.**

Center Rod 43 ft-lbf (60 N-m)  
Out Chambers 29 ft-lbf (40 N-m)

**Tightening torque for manifold retainer bolts.**

BST-FDA 18 ft-lbf (25 N-m)

**General Tools:**

- Socket Wrenches: 13mm, 17mm, 19mm, 24mm
- Hexagonal Box Wrenches: 5mm, 6mm
- Open-end wrenches: 19mm, 24mm

**Special Tools:**

- Sleeve Remover (713180) (sold separately)

**Miscellaneous**

- Assembly Oil
- Nuts M16 x 1.5
- Thread Locker
- Urea grease grade (NLGI) No. 2

**Customer Notes**

Model #: \_\_\_\_\_  
 Description: \_\_\_\_\_  
 Serial #: \_\_\_\_\_  
 Date Installed: \_\_\_\_\_  
 Department Location: \_\_\_\_\_  
 Tag/Project: \_\_\_\_\_