

Please read and save this Repair Parts Manual. Read this manual and the General Operating Instructions carefully before attempting to assemble, install, operate or maintain the product described. Protect yourself and others by observing all safety information. The Safety Instructions are contained in the General Operating Instructions. Failure to comply with the safety instructions accompanying this product could result in personal injury and/or property damage! Retain instructions for future reference. AMT reserves the right to discontinue any model or change specifications at any time without incurring any obligation.

©2020 AMT Pump Company, A Subsidiary of The Gorman-Rupp Company, All Rights Reserved.

Periodic maintenance and inspection is required on all pumps to ensure proper operation. Unit must be clear of debris and sediment. Inspect for leaks and loose bolts. Failure to do so voids warranty.



Questions? Call 1-800-810-1053



Diaphragm Pumps

DESCRIPTION

These diaphragm pumps are high capacity, self-priming (to 25 ft. lift), portable units shipped completely assembled (except for handle). The pumps are used for operation with fluids mixed with abrasive solids such as sand, silt, mud, sludge and waste. Not for use with pumping cement or mortar. Handles liquids from 40° to 180° F (4° to 82 ° C). Pump is capable of handling solids up to 1-5/8" diameter. For use with water and other non-flammable fluids compatible with pump component materials.

Model	Driver Type	Material	Diaphragm	Check Valve	Gear Box	Bearings	NPT
336Z-96	Hatz 1B20 Diesel	Aluminum	Thermoplastic/TPE	Neoprene	Oil Bath	Needle	2"
336G-96	Honda GX120	Aluminum	Thermoplastic/TPE	Neoprene	Oil Bath	Needle	2"
336E-96	1.5 HP 115 VAC @60 Hz	Aluminum	Thermoplastic/TPE	Neoprene	Oil Bath	Needle	2"
335A-96	B&S 525 Series	Aluminum	Thermoplastic/TPE	Neoprene	Oil Bath	Needle	3"
335G-96	Honda GX120	Aluminum	Thermoplastic/TPE	Neoprene	Oil Bath	Needle	3"
335E-96	1.5 HP 115 VAC @60 Hz	Aluminum	Thermoplastic/TPE	Neoprene	Oil Bath	Needle	3"
335B-96	B&S CP550	Aluminum	Thermoplastic/TPE	Neoprene	Oil Bath	Needle	3"
335H-96	Honda GX160	Aluminum	Thermoplastic/TPE	Neoprene	Oil Bath	Needle	3"
335Z-96	Hatz 1B20 Diesel	Aluminum	Thermoplastic/TPE	Neoprene	Oil Bath	Needle	3"

NOTE: Driver is subject to change without notice, see labels and manual with driver for operation, specifications, maintenance and warranty.

UNPACKING

After unpacking the unit, inspect carefully for any damage that may have occurred during transit. Check for loose, missing or damaged parts.

Specific Safety Information for Gasoline Engine Driven Pumps

- Carefully read the instruction manuals supplied by the engine manufacturer before attempting to assemble, disassemble or operate the engine or any other part. The "Warning" and "Caution" statements in this manual signal potentially hazardous conditions to the operator or equipment. Know when these conditions can exist. Take necessary steps to protect personnel, as well as equipment.

▲ WARNING

Gasoline is a highly combustible fuel. Use it with care! The improper use, handling and/or storage of gasoline can be dangerous. Help prevent accidents by following these safety rules:

- Use gasoline only as a fuel, never as a cleaning fluid.
- Always use an approved container to hold or store gasoline. Never store gasoline in familiar containers such as milk gallons or soda pop bottles.
- Never store gasoline near a heater or an open flame.
- When storing or using gasoline, make sure container is out of the reach of children.
- Never add gasoline to a running or hot engine. Spilled gasoline on a hot engine may cause a fire or an explosion. Fill gasoline tank outdoors and wipe up any spills.
- Have a fire extinguisher nearby. Be sure extinguisher is in operating condition – check the pressure gauge or indicator. Be familiar with its proper use. Consult the local fire

department for the correct type of extinguisher for your application. Extinguishers rated ABC by the National Fire Protection Association are appropriate for all applications.

- On permanent installations, be sure all fuel supplies have a positive shutoff valve. Fuel lines must be of steel piping, adequately secured and free from leaks. Do not use copper piping on flexible lines as copper becomes hardened and brittle and will break. Use black pipe on natural gas or gaseous fuels, but not on gasoline or diesel fuels. Piping at the engine should be a suitable flexible line that is compatible with the fluid.

Positively no smoking!

- Check engine oil, fuel levels and gear box oil levels before initial startup each day. Stay away from moving parts due to the danger of becoming caught in moving parts. Avoid loose jackets, shirts, sleeves and ties. Make sure all nuts and bolts are secure. Keep power shields and guards in place. If adjustment MUST be made while the unit is running, use extreme caution around hot manifolds, moving parts, etc.
- Do not work with this equipment when mentally or physically fatigued.
- Be careful not to touch the exterior of the engine, especially the muffler and the area around it. It is hot enough to be painful or cause injury.
- To prevent accidental starting, always remove the spark plug or disconnect and ground the spark plug wire before working on the engine or the equipment driven by the engine.
- DO NOT RUN THE ENGINE IN AN ENCLOSED AREA!!** Exhaust gases contain carbon monoxide, which is an odorless and deadly gas that will cause death if breathed too long. If equipment is located in an enclosed area with an

Diaphragm Pumps

exhaust line to the outside, regularly check the exhaust system for leaks. Be sure the area is well ventilated.

- If the gas engine is equipped with a spark arrester screen in the muffler, it should be inspected for wear periodically and replaced when necessary.

Specific Safety Information for Electric Motor Driven Pump

- This unit is not waterproof and is not intended to be used in potentially wet locations. The motor is designed to be used in a clean dry location with access to an adequate supply of cooling air. Ambient temperature around the motor should not exceed 104° F (40° C). For outdoor installations, motor must be protected by a cover that does not block air flow to and around the motor. This unit is not weatherproof nor is it able to be submersed in water.
- When wiring an electrically driven pump, follow all electrical and safety codes, as well as the most recent United States National Electrical Code (NEC) and the Occupational Safety and Health Act (OSHA).

▲ WARNING

Risk of electrical shock! Never connect the green (or green and yellow) wire to a live terminal.

- To reduce the risk of electric shock, the motor must be securely and adequately grounded!. This can be accomplished by either: (1) inserting plug (portable) directly into a properly installed and grounded 3-prong grounding-type receptacle (as shown in Figure 2); (2) permanently wiring the unit with a grounded metal raceway system; (3) using a separate ground wire connected to the bare metal of the motor frame; or (4) other suitable means. The green (or green and yellow) conductor in the cord is the grounding wire. The motor must be securely and adequately grounded for your protection against shock hazards! Where a 2-prong wall receptacle is encountered, it must be replaced with a properly grounded 3-prong receptacle with a grounded 3-prong receptacle installed in accordance with the National Electrical Code and local codes and ordinances. To ensure a proper ground, the grounding means must be tested by a qualified electrician. Use only 3-wire extension cords that have 3-prong, grounding-type plugs and 3-pole receptacles that accept the equipment plug.
- All wiring should be performed by a qualified electrician.

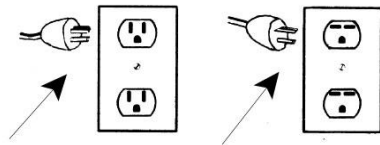

Grounding blade

Figure 2 Grounding Methods

▲ WARNING

An incorrect connection may cause an electric short, produce an electrical shock or burn out the pump motor, resulting in property damage and/or personal injury.

- Protect electrical cord from sharp objects, hot surfaces, oil and chemicals. Avoid kinking the cord. Replace or repair damaged or worn cords immediately.
- Provide safety shields on all moving and electrical parts to prevent personal injury.
- Keep fingers and foreign objects away from ventilation and other openings. Do not insert any objects into the motor.
- Use wire of adequate size to minimize voltage drop at the

- motor.
- Disconnect power before servicing a motor or its load. If the power disconnect is out of sight, lock it in the open position and tag it to prevent unexpected application of power.
- Do not touch an operating motor. Modern motors are designed to operate at high temperatures.

General Safety Information (All Units)

- Know the pump application, limitations and potential hazards.

▲ WARNING

Do not use to pump flammable or explosive fluids such as gasoline, fuel oil, or kerosene, etc. Do not use in flammable and/or explosive atmospheres. Pump should only be used with liquids compatible with pump component materials. Failure to follow this warning can result in personal injury and/or property damage.

- Make certain that the power source conforms to the requirements of your equipment.
- Provide adequate protection and guarding around moving parts.
- Disconnect power before servicing.
- Release all pressure within the system before servicing any component.
- Drain all liquids from the system before servicing.
- Secure the discharge line before starting the pump. An unsecured discharge line will whip, possibly causing personal injury and/or property damage.
- Check hoses for weak or worn condition before each use, making certain that all connections are secure.
- Periodically inspect pump and system components. Perform routine maintenance as required (see Maintenance Section).
- Provide a means of pressure relief for pumps whose discharge line can be shut off or obstructed.
- Personal Safety:**
 - Wear safety glasses at all times when working with pumps.
 - Wear a face shield and proper apparel when pumping hazardous chemicals.
 - Keep work area clean, uncluttered and properly lighted - replace all unused tools and equipment.
 - Keep visitors at a safe distance from the work area.
 - Make workshop childproof – with padlocks, master switches and by removing starter keys.
- For air drive units follow Safety Information in instruction sheet supplied with air motor.

ASSEMBLY

- HANDLE ON 2" PUMP** (Refer to Figure A)
 - Remove two hex cap screws (Ref. No. A6) and washers (Ref. No. A7) from gearbox (Ref. No. A1).
 - Place handle (Ref. No. A35) on gearbox flange and align holes.
 - Reinstall two hex cap screws and washer assemblies, then tighten.
- HANDLE ON 3" PUMP** (Refer to Figure A)
 - Remove two hex nuts from pump well (Ref. No. A3).
 - Place handle (Ref. No. A35) under pump well.
 - Reinstall two hex nut and washer assemblies, then tighten.
- ROTATING SUCTION/DISCHARGE PORTS (OPTIONAL)** (Refer to Figure A,W,P)

Diaphragm Pumps

In some applications, it may be preferable to have suction/discharge ports rotated 90 degrees to be in line with driver. If so, proceed as follows:

- a. Remove four hex cap screws (Ref. No. A9), hex nut (Ref. No. A13) and washers (Ref. Nos. A11 & A12) from pump assembly to separate pump well (Ref. No. A3) from pump base (Ref. No. A8).
- b. Rotate pump well 90 degrees clockwise so that driver is positioned over top of discharge plate (Ref. No. W7).
- c. Be sure that pump well base and diaphragm (Ref. No. P17) are aligned properly with one another. Then, reinstall four hex cap screws, hex nuts and washer assemblies and tighten.

GEAR BOX OIL (Refer to Figure A,G)

3. Place pump on a level surface. Fill pump gear box (Ref. No. A1) with gear box oil before the pump is operated. Gear oil must meet requirements of API GL-5 and military specification MIL-L-2105B. Remove gear box housing fill plug (Ref. No. G6). Remove level plug (Ref. No. G5). Pour gear oil into gear box slowly until oil comes out of level plug.

Warranty on this unit is void unless the gear box is lubricated with appropriate gear oil listed above. DO NOT OVER FILL!

INSTALLATION

NOTE: In any installation where property damage can occur by pumps not operating due to power outages, discharge line freezing or any other reason, a backup system(s) and/or warning system(s) should be used.

1. Place the pump on a level, solid foundation, locating it as close to the liquid as possible, making the suction line as short and direct as possible.
2. Install pipe nipples (Ref. No. A36) so the smoother side of pipe end faces the suction and discharge hose.

▲ CAUTION

Maximum discharge head is 25 feet or 10.9 psi. Operation over this head or pressure will cause pump to stall and/or gearbox damage. Use only rigid hoses.

3. Attach suction piping to the suction inlet (Ref. No. W2) and discharge piping to the discharge outlet (Ref. No. W7). The suction line should be positioned such that there is a continual upward slope from the fluid source to the pump. Avoid using loops or sections of pipe or fittings, which might permit air to become trapped.

NOTE: If hose is used, be sure to use reinforced hose on both the suction and discharge. **DO NOT USE** canvas or similar collapsible materials. **NEVER USE PIPE REDUCER; PIPE SIZE MUST BE EQUAL TO OR LARGER THAN PUMP PORT SIZE.** Suction line must be airtight so that air cannot leak in and destroy priming vacuum. On a permanent installation where piping is used, always connect a piece of flexible hose between pump and piping so pump is free to move slightly.

4. It is advisable to use a strainer (Ref. No. W16) on the inlet end of the suction hose or pipe. A properly sized strainer is supplied with this unit and should be used at all times to prevent damage. Keep the strainer clean. If possible, suspend it to keep it from becoming clogged with muck, roots, debris or leaves. It is best to keep hose free of kinks as they will restrict flow and add excess loading to pump and gearing.

5. **GASOLINE ENGINE UNITS:** Follow all instructions in the engine manual before starting the engine. Fill engine with oil, gasoline, etc.

AIR MOTOR UNITS: Follow all instructions in the air motor manual before starting unit.

ELECTRIC MOTOR UNITS: It is strongly recommended that this unit is plugged into a G.F.I. (Ground Fault Interrupter) circuit. Consult your local electrician for installation and availability.

6. Input RPM (to pump) – Input RPM must be between 1750 and 2750 RPM. Final pump speed will be 40 strokes/min. with a 1750 RPM input and 60 strokes/min. with a 2750 RPM input.

Do not exceed 60 strokes per minute with the diaphragm pump.

OPERATION

Operate the diaphragm pump in an upright position only.

1. This diaphragm pump is capable of priming "dry" up to fifteen feet; it will prime much faster when it is filled with clean water through priming cap (Ref. No. W6). Primed, it can lift to 25 feet.
2. Activate unit following engine or air motor manual or turning unit on if electrical.

▲ CAUTION

Do not control discharge capacity with a valve or similar device.

CLEARING JAM-UP

If large solids or an accumulation of sand or other sediment becomes lodged in the pump well (Ref. No. A3) preventing the plunger arm (Ref. No. A2) from making a full stroke, the pump should be thoroughly cleaned as described in "If Pump Stalls" shown below. Refer to parts list and illustration for parts identification.

▲ CAUTION

If pump has stopped or stalled for any unknown reason, clean out pump cavity thoroughly. Failure to comply with the "caution" could result in damage to crank (Ref. No. P5/P9), plunger arm (Ref. No. P1) or other parts of assembly.

1. IF PUMP STALLS:
 - a. Remove handle (Ref. No. A35).
 - b. Remove four bolts (Ref. No. A9 & A10).
 - c. Clean obstruction and all debris from pump well (Ref. No. A3).
 - d. Reassemble pump in reverse order of disassembly and return to service.
2. IF PLUNGER ARM (Ref. No. P1) SEIZES AND GEAR BOX OUTPUT SHAFT (Ref. No. G8) TURNS IN CRANK (Ref. No. P5):
 - a. Remove sheet metal guard (Ref. No. A4) by loosening hand knob screws (Ref. No. A5).
 - b. Disassemble pump and clean as described in steps (a) through (d) listed for stalled engine jam up.
 - c. Torque the crank lock screw (Ref. No. P6) to 70 foot pounds with an appropriate torque wrench (see Figure 3).

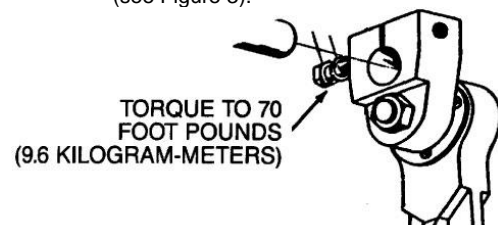

Figure 3

- d. Reassemble the pump in reverse order of disassembly and return to service.

Diaphragm Pumps

▲ WARNING

Pump jamming with an over-torqued lock screw may cause internal damage. Under torquing may allow the output shaft to spin and wear parts necessitating replacement.

MAINTENANCE

▲ WARNING

Make certain that unit is disconnected from power source before attempting to service or remove any component.

1. Check gear box oil level every 20 hours of operation or at least once a week; more often if any leakage is detected around the gear box. Change gearbox oil after the first 40 hours of operation. Fill to the oil level plug. Change gearbox oil every 350 hours of operation.
2. The plunger bearing (Ref. No. P3) must be greased (any automotive grease) after every 8 hours of use. This is done by rotating plunger bearing to the 12 o'clock position. At this point, grease fitting will be visible through hole in guard (Ref. No. A4). Bearing may be cleaned and kept well lubricated by pumping grease slowly into fitting until new grease oozes out between bearing and journal.
3. During freezing weather, be sure to drain the pump when it is not running. Remove discharge hose and tip unit towards discharge side.
4. Keep pump clean. After use with liquids containing foreign materials, flush with clean water.

REPLACEMENT OF FLAPPER VALVE

(Ref. No. W15)

1. Remove two bolts (Ref. No. W3) and remove suction priming chamber (Ref. No. W2). Replace flapper (Ref. No. W15) on flapper pin to locate on priming chamber.
2. Remove two bolts (Ref. No. W8) and remove discharge plate (Ref. No. W7). Replace flapper valve on flapper pin to locate valve on pump well (Ref. No. W1).

REPLACEMENT OF DIAPHRAGM

(Ref. No. P17)

1. Remove sheet metal guard (Ref. No. A4) by loosening hand knob screws (Ref. No. A5).
2. Rotate pump until plunger arm (Ref. No. A2) is in the down position.
3. Remove handle (Ref. No. A35).
4. Remove pump well (Ref. No. A3) by removing screws, (Ref. No. A9/A10).
5. Remove diaphragm by removing three nuts (Ref. No. P12) from bolts (Ref. No. P11).
6. Replace diaphragm and reverse steps 1 through 5 for reassembly.

GEAR BOX OVERHAULING

A completely assembled gear box is available as a replacement part (Ref. No. G28).

DISASSEMBLY

1. Remove diaphragm (Ref. No. P13) as described in "Replacement of Diaphragm".
2. Remove crank (Ref. No. P5) by removing machine screw (Ref. No. P6). Use screwdriver in slot of crank to release clamp on output shaft (Ref. No. G8).
3. Drain oil from gear box by removing drain plug (Ref. No. G4).
4. Remove driver (Ref. Nos. A28/A32) from adapter (Ref. No. G26) by removing four bolts (Ref. No. A27) plus 4 additional bolts (Ref. No. A29) from engine mount bracket (Ref. No. A16) for gas driver models. Slide driver back from adapter until driver shaft disengages pinion (Ref. No. G20).
5. Remove adapter by removing four bolts (Ref. No. G27).

6. Remove gear box from pump base (Ref. No. A8) by removing four bolts (Ref. No. A9 & A10).
7. Remove pinion/bearing assembly (Ref. Nos. G15, G24, G20, G16) by pulling straight out. Use a slide hammer puller gripping in pinion groove
8. Remove twelve bolts (Ref. No. G3) holding gear box halves (Ref. Nos. G1 & G2) together.
9. Carefully separate gearbox halves.
10. Remove gasket (Ref. No. G22).
11. Remove output shaft/bearing assembly (Ref. Nos. G8, G9, G12, G11, G12, G13) and idler pinion/bearing assembly (Ref. Nos. G13, G14, G17, G18, G19).
12. Remove output shaft oil seal (Ref. No. G23)
13. Remove bearings (Ref. Nos. G15 & G16) from ends of input pinion shaft (Ref. No. G20).
14. Remove bearings (Ref. Nos. G13 & G14) from ends of idler pinion shaft (Ref. No. G17).
15. Remove internal spur gear (Ref. No. G19) and key (Ref. No. G18) from idler pinion shaft.
16. Remove retaining ring (Ref. No. G10) and bearings (Ref. Nos. G12 & G13) from ends of output shaft (Ref. No. G8).
17. Remove output gear (Ref. No. G11) and key (Ref. No. G9) from output shaft.

REASSEMBLY

1. Assemble input pinion/bearing assembly, idler pinion/bearing assembly and output shaft/bearing assembly.
2. Install output shaft oil seal into gearbox output half. Lubricate lip seal.
3. Slide output shaft through lip seal. Start output bearing in bore in gear box output half. Position idler pinion bearing assembly in its bore in output half. Simultaneously press both assemblies into output half.
4. Install gasket on output half.
5. Position gear box input half; align shaft bearings with bearing bores. Press gear box halves together, align pins in output half with pin bore in input half.
6. Secure halves together with twelve bolts.
7. Slide input pinion/bearing assembly into bore in gear box input half. Rotate pinion during installation to make sure gear teeth align with internal spur gear teeth.
8. Install O-ring (Ref. No. G25) on outside of pinion bearing.
9. Reassemble gear box to pump base with four bolts.
10. Reassemble adapter to gear box with four bolts.
11. Align driver shaft key (Ref. No. A26) with keyway in pinion. Slide driver into pinion, secure to adapter with four bolts (Ref. No. A27).
 - a. **(Gas engine only)** Attach engine to engine mount with four additional screw assemblies (Ref. No. A29).
12. Reassemble crank to output shaft as described under "Operation" section.
13. Replace diaphragm as described under "Replacement of Diaphragm" section.
14. Fill gear box with oil as described under "Assembly" section.
15. Pump should be checked daily, weekly, monthly for proper operation.

NOTE: Only qualified service personnel should attempt to repair this unit. Improper repair and/or assembly can cause pump damage, driver damage and/or an electrical shock hazard depending on model.

Diaphragm Pumps

Symptom	Possible Cause(s)	Corrective Action
Pump will not prime or retain prime after operating	<ol style="list-style-type: none"> 1. Air leak in suction line 2. Defective flapper valves 3. Clogged foot valve or strainer 4. No liquid in suction line 5. Material jammed in pump well 	<ol style="list-style-type: none"> 1. Repair or replace 2. Replace 3. Clean or replace 4. Fill suction line & pump with liquid 5. Clean (See Maintenance)
Flow rate is slow	<ol style="list-style-type: none"> 1. Incorrect driver speed 2. Piping is fouled or damaged 3. Clogged pump 4. Discharge line restricted or undersized 5. Collapsible discharge hose 6. Too many bends 7. Lines are too long 	<ol style="list-style-type: none"> 1. Increase speed (see Specifications) 2. Clean or replace 3. Clean 4. Flush out piping or replace 5. Replace with rigid or non-collapsible hose 6. Straighten hose 7. Shorten lines
Pump runs but no fluid	<ol style="list-style-type: none"> 1. Faulty suction piping 2. Pump located too far from fluid source 3. Gate valve closed 4. Clogged strainer 5. Discharge height too great 	<ol style="list-style-type: none"> 1. Replace 2. Place pump closer to source 3. Open gate valve 4. Clean or replace 5. Lower discharge height
Pump starts and stops pumping	<ol style="list-style-type: none"> 1. Leak in suction line 2. Leak in foot valve 3. Diaphragm has a crack or hole 4. Defective or clogged flapper valves 	<ol style="list-style-type: none"> 1. Repair 2. Repair or replace 3. Replace 4. Clean or replace
Excessive noise while pump in operation	<ol style="list-style-type: none"> 1. Pump not secured to firm foundation 2. Restricted suction line 	<ol style="list-style-type: none"> 1. Secure properly 2. Clean or correct
Pump stalls repeatedly or stops for no apparent reason	<ol style="list-style-type: none"> 1. Discharge height over 25 feet of head 2. Material jammed in pump well 	<ol style="list-style-type: none"> 1. Lower height (see Specifications) 2. Clean out pump well (See Operation & Maintenance section)

For Repair Parts contact dealer where pump was purchased.

Please provide following information:

- Model Number
- Serial Number (if any)
- Part description and number as shown in parts list

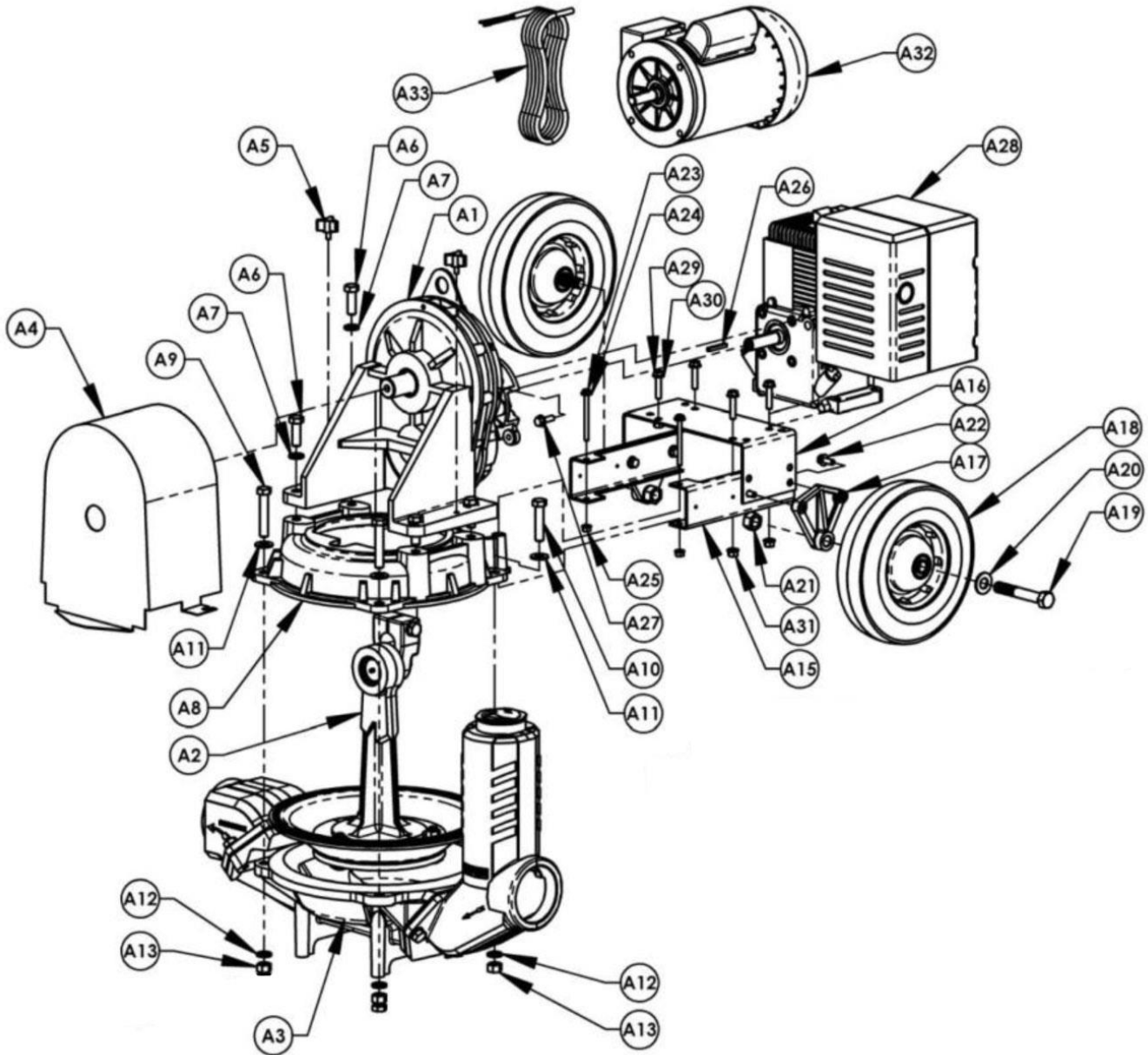

Assembled Pump – Figure A

Repair Parts List - Assembled Pump (Reference Figure A)

Ref. No.	Description	3" Engine Driven Pump Part Number	3" Motor Driven Pump Part Number	2" Engine Driven Pump Part Number	2" Motor Driven Pump Part Number	Qty.
A1	Gearbox Assembly	Ref. Page 8	Ref. Page 8	Ref. Page 8	Ref. Page 8	1
A2	Plunger/Diaphragm Assembly	Ref. Page 10	Ref. Page 10	Ref. Page 10	Ref. Page 10	1
A3	Well Assembly	Ref. Page 11	Ref. Page 11	Ref. Page 11	Ref. Page 11	1
A4	Plunger Guard	3354-103-00	3354-103-00	3354-103-00	3354-103-00	1
A5	¼-20X1/2 Plastic Knob	1716-010-00	1716-010-00	1716-010-00	1716-010-00	2
A6	½-13x1-1/2 Hex Head Cap Screw	1766-013-00	1766-013-00	1766-013-00	1766-013-00	2 (3" Version) 4 (2" Version)
A6	½-13x2-1/4 Hex Head Cap Screw	1766-016-00	1766-016-00	N/A	N/A	2
A7	½ Lock Washer	1798-001-00	1798-001-00	1798-001-00	1798-001-00	4
A8	Base	3354-001-01	3354-001-01	3360-020-01	3360-020-01	1
A9	½-13x2-1/4 Hex Head Bolt Grade-5	1766-016-00	1766-016-00	1766-016-00	1766-016-00	2
A10	½-13x2-1/4 Hex Head Bolt Grade-5	1766-016-00	1766-016-00	1766-016-00	1766-016-00	2
A11	½ Flat Washer	1798-002-00	1798-002-00	1798-002-00	1798-002-00	4
A12	½ Lock Washer	1798-001-00	1798-001-00	1798-001-00	1798-001-00	4
A13	½-13 Hex Nut	1782-002-00	1782-002-00	1782-002-00	1782-002-00	4
A15	Mount Brace	3354-107-00	3354-107-00	3354-107-00	3354-107-00	2
A16	Engine Mount	3354-108-00	3354-108-00	3354-108-00	3354-108-00	1
A16	Engine Mount Kit for Hatz	335Z-101-90	N/A	335Z-101-90	N/A	1
A17	Wheel Bracket	3354-109-00	3354-109-00	3354-109-00	3354-109-00	2
A18	Wheel	1663-000-00	1663-000-00	1663-000-00	1663-000-00	2
A19	5/8-11x4 Hex Head Bolt	1769-000-00	1769-000-00	1769-000-00	1769-000-00	2
A20	5/8 Flat Washer	1799-000-00	1799-000-00	1799-000-00	1799-000-00	2
A21	5/8-11 Hex Nut	1782-020-00	1782-020-00	1782-020-00	1782-020-00	2
A22	5/16-18x3/4 Hex Flange Screw	1745-002-00	1745-002-00	1745-002-00	1745-002-00	4
A23	¼-20x3 Hex Head Bolt	1734-013-00	1734-013-00	1734-013-00	1734-013-00	2
A24	¼ Flat Washer	1789-000-00	1789-000-00	1789-000-00	1789-000-00	2
A25	¼-20 Hex Nut	1776-000-00	1776-000-00	1776-000-00	1776-000-00	2
A26	3/16 Square Key	1517-001-00	1517-001-00	1517-001-00	1517-001-00	1
A27	5/16-24x1 Hex Flange Screw	1753-000-00	N/A	1753-000-00	N/A	4
A27	3/8-16X1-1/4 Hex Head Cap Screw	N/A	1757-003-00	N/A	1757-003-00	4
A28	Engine ¾ Keyed PTO	See Chart	N/A	See Chart	N/A	1
A29	5/16-18x1-1/2 Hex Head Bolt	1748-000-00	N/A	1748-000-00	N/A	4
A29	5/16-18 x ¾ Hex Bolt (Hatz)	1745-002-00	N/A	1745-002-00	N/A	4
A30	5/16 Flat Washer	1790-000-00	N/A	1790-000-00	N/A	4
A31	5/16-18 Hex Nut	1785-000-00	N/A	1785-000-00	N/A	4
A32	Motor	N/A	1626-095-00	N/A	1626-095-00	1
A33	Cord Assembly	N/A	335E-352-90	N/A	335E-352-90	1
A34	Switch Assembly (not shown)	N/A	335E-350-90	N/A	335E-350-90	1
A35	Handle Kit (not shown)	3354-116-90	3354-116-90	3354-116-90	3354-116-90	1
A36	Nipple Pack (2 NPT nipples)	3270-170-00	3270-170-00	3160-170-00	3160-170-00	1

Repair Parts List - Engine Chart

Ref. No.	Description	3" Pump Model Number	2" Pump Model Number	Part Number	Qty.
A28	Honda GX120UT1QX2	335G-96	336G-98	1630-007-00	1
A28	Honda GX160UT1QX2	335H-96	N/A	1639-017-00	1
A28	Hatz 1B20	335Z-96	336Z-96	DISCONTINUED	1
A28	Hatz 1B30	335Z-96	336Z-96	1630-037-90	1
	Honda GX160 Spark Arrestor Kit (not shown)	335H-96	N/A	1639-001-90	1

Order Online: www.PumpCatalog.com

For Repair Parts contact dealer where pump was purchased.

Please provide following information:

- Model Number
- Serial Number (if any)
- Part description and number as shown in parts list

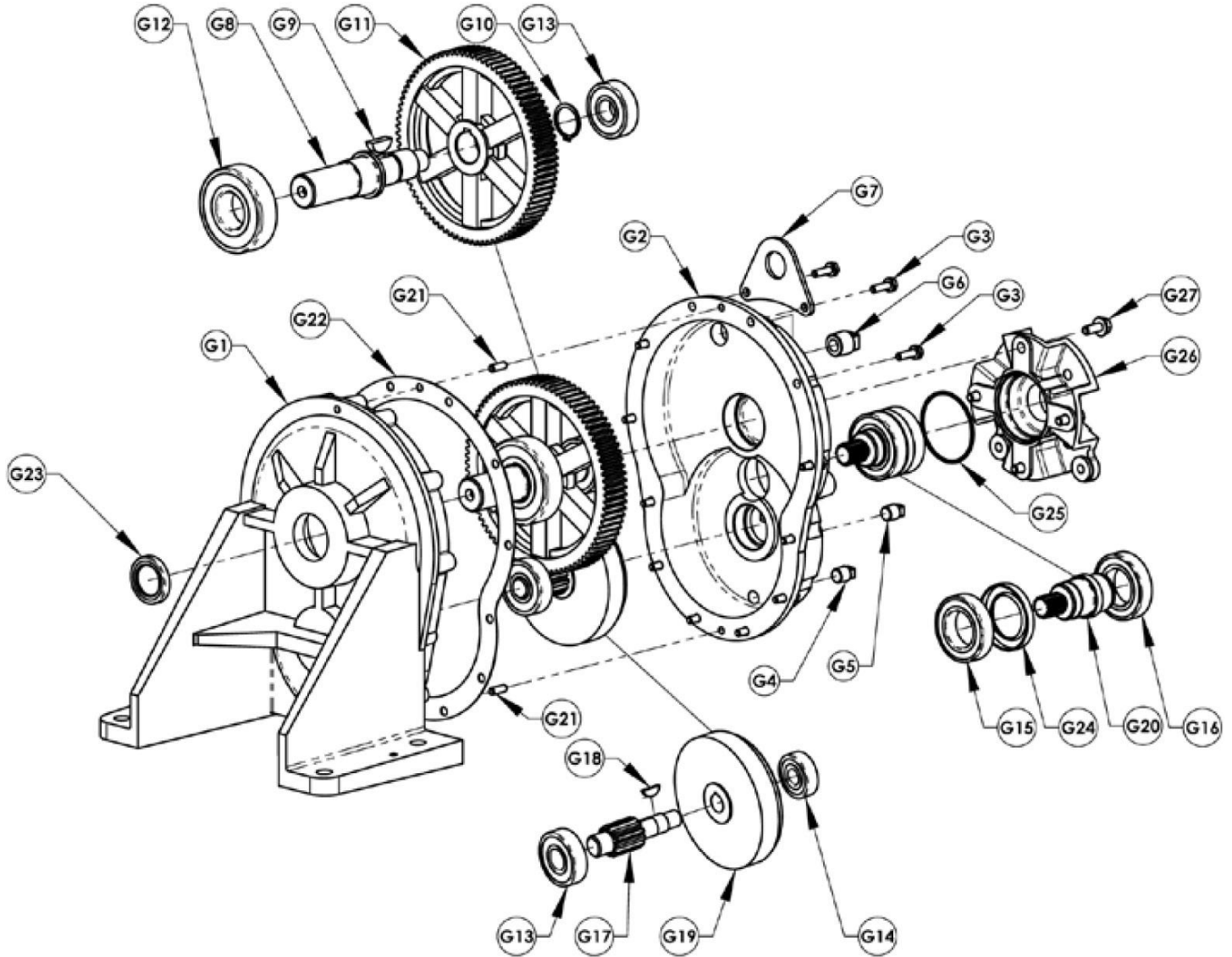

Gearbox – Figure G

Repair Parts List - Gearbox (Reference Figure G)

Ref. No.	Description	3" Pumps		2" Pumps	
		Part Number	Qty.	Part Number	Qty.
G1	Gearbox Output Half	3354-090-01	1	3354-090-01	1
G2	Gearbox Input Half	3354-091-01	1	3354-091-01	1
G3	¼-20x7/8" Screws and Washer Kit (12 each)	3354-420-90	1	3354-420-90	1
G4	¼ NPT Plug (drain) (kit includes 1)	1767-002-00	1	1767-002-00	1
G5	¼ NPT Plug (oil level) (kit includes 1)	1767-002-00	1	1767-002-00	1
G6	½ NPT Vented Plug (fill) (kit includes 1)	1767-001-00	1	1767-002-00	1
G7	Lift Bracket	3354-106-00	1	3354-106-00	1
G8	Output Shaft	3354-140-00	1	3354-140-01	1
G9	Woodruff Key #1008	2141-000-00	1	2141-000-00	1
G10	External Retaining Ring SH-112	1806-064-00	1	1806-064-00	1
G11	Output Gear	3354-120-00	1	3354-120-00	1
G12	Bearing –Open- 35x80x21 #6307 JEM	3354-190-00	1	3354-190-00	1
G13	Bearing –Open- 20x52x15 #6304 JEM	3354-191-00	2	3354-191-00	2
G14	Bearing –Open- 15x42x13 #6302 JEM	3354-192-00	1	3354-192-00	1
G15	Bearing –Open- 35x62x14 #6007 JEM	3354-194-00	1	3354-194-00	1
G16	Bearing –Sealed- 35x62x14 #6007 2RSJEM	3354-193-00	1	3354-193-00	1
G17	Idler Pinion Shaft	3354-121-00	1	3354-121-00	1
G18	Woodruff Key #406	2157-000-00	1	2157-000-00	1
G19	Internal Spur Gear	2149-000-00	1	2149-000-00	1
G20	Input Pinion (3/4 keyed engine)	3354-122-00	1	3354-122-00	1
G20	Input Pinion (5/8 keyed 56C motor)	3354-123-00	1	3354-123-00	1
G21	1/4x1 Dowel Pin	1717-002-00	1	1717-002-00	1
G22	Gasket	3354-300-00	1	3354-300-00	1
G23	Oil Lip Seal 1.25x1.75x0.25	2148-000-00	1	2148-000-00	1
G24	Oil Lip Seal 40x62x8	2148-001-00	1	2148-001-00	1
G25	O-Ring- Buna #143	2181-005-00	1	2181-005-00	1
G26	Adapter (engine)	3354-093-01	1	3354-093-01	1
G26	Adapter (56C motor)	3354-092-01	1	3354-092-01	1
G27	5/16-18x3/4 Hex Flange Screw	1745-002-00	4	1745-002-00	1
G28	Assembled Gearbox for Gas Engine Models (includes Ref. Nos. G1 thru G24)	3354-402-90	1	3360-402-90	1
G28	Assembled Gearbox for Electric Models (includes Ref. Nos. G1 thru G24)	3354-403-90	1	3360-403-90	1

Order Online: www.PumpCatalog.com

For Repair Parts contact dealer where pump was purchased.

Please provide following information:

- Model Number
- Serial Number (if any)
- Part description and number as shown in parts list

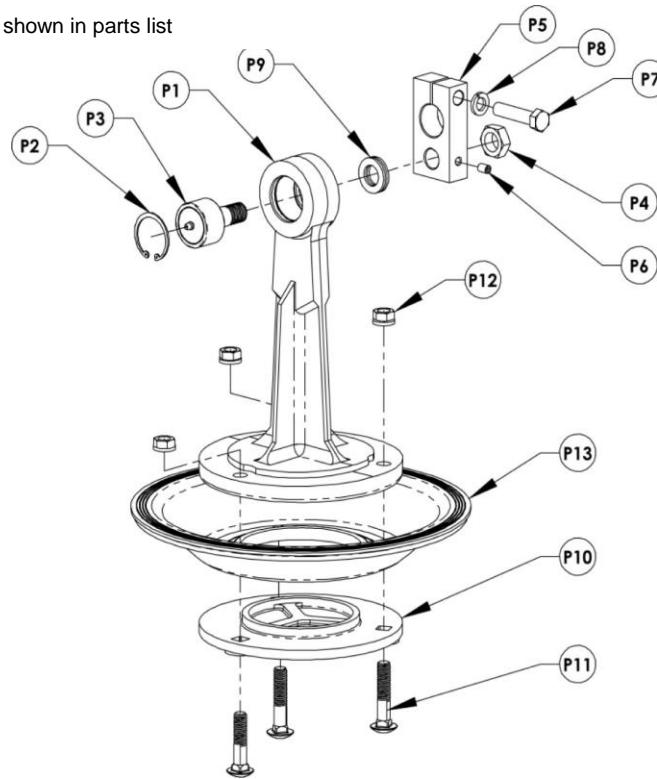

Plunger Assembly – Figure P

Repair Parts List - Plunger Assembly (Reference Figure P)

Ref. No.	Description	3" Pumps Part Number	Qty.	2" Pumps Part Number	Qty.
P1	Plunger	2134-000-01	1	3360-090-01	1
P2	Retaining Ring	3350-190-00	1	3360-191-00	1
P3	Plunger Bearing (includes Ref. No. P4)	2138-000-90	1	3360-190-90	1
P4	Bearing Lock Nut	Incl. w/P3	1	Incl. w/P3	1
P5	Crank Assembly Kit (includes Ref. Nos. P6, P7, P8, P9)	2140-000-90	1	3360-094-90	1
P6	5/16-18x1/2 Socket Set Screw	Incl. w/P5	1	Incl. w/P5	1
P7	½-13 Hex Head Cap Screw Grade-5	Incl. w/P5	1	Incl. w/P5	1
P8	½ Lock Washer	Incl. w/P5	1	Incl. w/P5	1
P9	Bearing Shim	Incl. w/P5	2	Incl. w/P5	1
P10	Diaphragm Retaining Plate	2133-000-00	1	3360-092-00	1
P11	Carriage Bolt Kit	3350-011-90	1	3360-011-90	1
P12	½-13 Hex Nut	1782-001-00	3	N/A	-
P12	3/8-16 Hex Nut	N/A	-	1780-000-00	3
P13	Diaphragm (Santoprene)	2132-000-00	1	3360-300-00	1

Order Online: www.PumpCatalog.com

For Repair Parts contact dealer where pump was purchased.

Please provide following information:

-Model Number

-Serial Number (if any)

Part description and number as shown in parts list

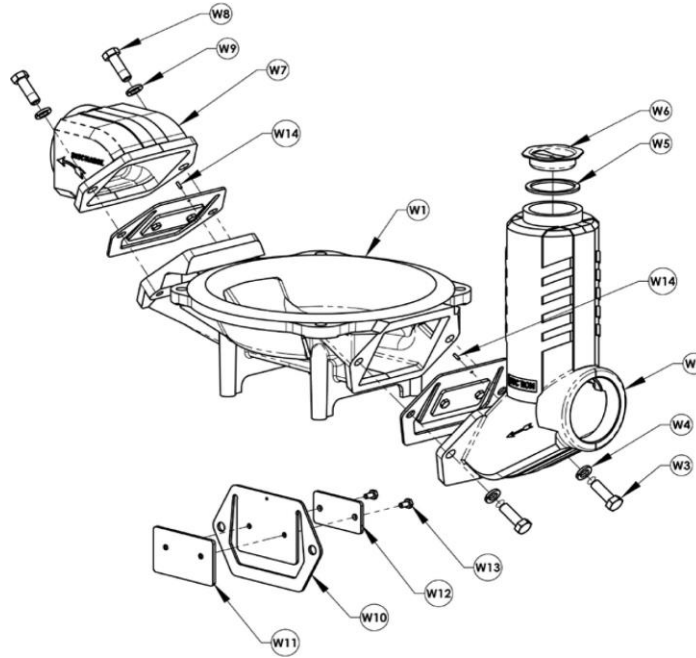

Well Assembly – Figure W

Repair Parts List - Well Assembly (Reference Figure W)

Ref. No.	Description	3" Pumps		2" Pumps	
		Part Number	Qty.	Part Number	Qty.
W1	Well	2120-001-00	1	3360-001-01	1
W2	Suction Plate	2123-000-01	1	3360-050-01	1
W3	½-13x1-1/2 Hex Head Cap Screw Grade-5	1766-013-00	2	N/A	-
W3	3/8-16x1-1/2 Hex Head Cap Screw Grade-5	N/A	-	1759-001-00	2
W4	½ Lock Washer	1798-001-00	2	N/A	-
W4	3/8 Lock Washer	N/A	-	1793-001-00	2
W5	Gasket	Incl. w/W6	1	Incl. w/W6	1
W6	Cap	2124-000-00	1	2124-000-00	1
	(includes Ref. Nos. W5, W6)				
W7	Discharge Plate	2131-000-01	1	3360-052-01	1
W8	½-13x1-1/2 Hex Head Cap Screw Grade-5	1766-013-00	2	N/A	-
W8	3/8-16x1-1/2 Hex Head Cap Screw Grade-5	N/A	-	1759-001-00	2
W9	½ Lock Washer	1798-001-00	2	N/A	-
W9	3/8 Lock Washer	N/A	-	1793-001-00	2
W10	Check Valve (neoprene)	Incl. w/W15	2	Incl. w/W15	2
W11	Check Valve Weight Top	Incl. w/W15	2	Incl. w/W15	2
W12	Check Valve Weight Bottom	Incl. w/W15	2	Incl. w/W15	2
W13	¼-20x1/2 Hex Head Cap Screw	Incl. w/W15	4	Incl. w/W15	4
W14	1/8 diameter x 3/8 Pin	2121-000-00	2	2121-000-00	2
W15	Flapper Valve Assembly Kit	3354-071-90	2	3360-070-90	2
	(includes Ref. Nos. W10, W11, W12, W13)				
W16	Suction Strainer (not shown)	1680-000-00	1	C230-170-00	1
	Suction Strainer w/ Hose Shank Kit for British Threads	C311-999-90	1	N/A	
W17	NPT x BSPT Pipe Nipple Kit	C370-999-90	1	C369.9999-90	1

Order Online: www.PumpCatalog.com



AMT Pump Company
(herein "AMT")
400 Spring Street
Royersford, PA 19468
Phone: (610) 948-3800
Fax: (610) 948-5300
www.amtpump.com



General Information

SALES POLICY: AMT products are sold through our established Distributors. We do not sell direct to the consumer or organization not entitled to trade recognition. Therefore, possession of our catalogs and/or price list(s) does not infer an offer to sell.

MINIMUM ORDER: We appreciate your order, however, all orders are subject to a minimum \$35.00 net invoice charge (excluding freight). This applies to all pump and parts purchase orders.

PRICES: Prices are subject to change without notice. All orders accepted are subject to prices in effect at time of shipment.

PAYMENT TERMS: Terms, upon establishment of credit, are Net 30 days. Past due accounts may be subject to a service charge of 1.5% per month. Domestic or assignable letter of credit is required for all export trade.

PAST DUE ACCOUNTS: AMT reserves the right to withhold open account shipments on any past due account. Invoices are considered past due after thirty (30) days. In the interest of sound business, all orders are subject to approval of the Credit Department.

SHIPPING INSTRUCTIONS: All shipments will be made F.O.B. the factory. Where instructions for shipment do not appear on the order, the shipment will be made according to our best judgment. Full risk of loss (including transportation delays and losses) shall pass to the customer upon delivery of the products to the carrier at the F.O.B. point. When loss or delay occurs, primary responsibility for tracing rests with the customer. When there is LOSS or APPARENT VISIBLE DAMAGE to a shipment, when tendered for delivery, *DO NOT* give the carrier a clear receipt. Note such damage on the carrier's delivery receipt and *HAVE THE DRIVER SIGN THE RECEIPT.*

PRODUCT REVISIONS: AMT reserves the right to discontinue, change or improve its products or any portions thereof without being obligated to provide such a change or improvement for units sold and/or shipped prior to such a change or improvement.

12 Month Limited Warranty

EXTENT AND DURATION OF LIMITED WARRANTY

Coverage: AMT Pump Company (herein "AMT") or IPT Pumps by Gorman-Rupp (herein "IPT") or Gorman-Rupp Industries Division of the The Gorman-Rupp Company, Patterson, or the Gorman-Rupp Company (herein referred to as "G-R Unit") each individually warrants that its products and parts shall be free from defects in material and workmanship for twelve (12) months from the date of purchase by the original end user when installation is made and maintenance is performed in accordance with G-R Unit's recommendations. Wear and tear resulting from use and items normally consumed in use are not covered.

EXCEPTIONS

(A) This Limited Warranty shall not apply to mechanical seals in AMT or IPT pumps and the following products and parts: engines, motors, trade accessories and all other products, components, parts and materials not manufactured by the G-R Units. These items may, however, be covered by the warranties of their respective manufacturers.
(B) This warranty does not extend to or apply to any unit which has been repaired or altered at any place other than by a G-R Unit, or by persons not expressly approved by a G-R Unit to make repairs or alterations, nor to any unit the serial number, model number or identification of which has been removed, defaced or altered. (C) This warranty does not extend to any product manufactured by a G-R Unit, which has been subjected to mis-use, neglect, accident, improper installation, or use in violation of instructions furnished by a G-R Unit. (D) Pump Kits: This warranty does not extend to any product sold by a G-R Unit unassembled as a Pump Kit. Pump Kits are warranted against defects in material and workmanship for 60 days from the date of shipment from a G-R Unit. Any Pump Kit parts deemed defective by a G-R Unit will be replaced free of charge within 60 days of shipment. Pump Kits are not returnable for credit.

LIMITATIONS

THE G-R UNITS' SOLE AND EXCLUSIVE WARRANTY WITH RESPECT TO THEIR PRODUCTS AND PARTS IS THIS LIMITED WARRANTY. THIS LIMITED WARRANTY IS IN LIEU OF ALL OTHER EXPRESS AND/OR IMPLIED WARRANTIES, INCLUDING IMPLIED WARRANTIES OF MERCHANTABILITY AND FITNESS FOR PARTICULAR PURPOSE.

EXCLUSIVE REMEDY AND DAMAGES

The sole and exclusive remedy for breach of this Warranty by a G-R Unit and the entire extent of its liability for such breach or for damages arising from the use of the products and parts covered under this Limited Warranty, shall be as follows:

LEAD TIME: Products designated "Quick Ship Product", also referred to as "QSP" will normally be shipped within 24 hours of receipt of a non-cancellable purchase order. Only limited quantities of "QSP" pumps are available.

STANDARD LEAD TIME: Lead time is two weeks for all non "QSP" product. AMT reserves the right to revise lead times as required due to availability of materials and all other causes beyond our control.

VIP SHIPMENT: Select AMT and IPT branded pumps are available for next day shipment for non-QSP (Quick Ship Products) items and subjected to a specific model surcharge per unit noted in the respective price book. Requires calling for availability, confirmation and a non-cancellable purchase order or credit card payment prior to shipment. The expedited shipping charges are an additional cost added separately from the VIP charges per item. AMT reserves the right to revise lead times as required due to availability of materials and all other causes beyond our control. QSP quantities are limited as determined by AMT.

ALL purchase orders must be submitted via hard copy sent to AMT customer service department by fax, EDI or e-mail.

RETURN GOODS POLICY: Goods shall not be returned without a return goods authorization number (RGA) issued by AMT customer service. The RGA number must be listed on the packing list. Only current model and part numbers with a valid date code may be returned (within one year from date of purchase). **A 20% restocking and packaging charge will apply to all returns. All shipping charges must be pre-paid. No exceptions.**

ORDER CHANGES BY CUSTOMER: Orders in process may not be changed except with written consent and may be subject to special charges.

1. **Repair or Replacement:** If inspection shows that any G-R Unit product or part covered under this Limited Warranty is defective in materials or workmanship, the G-R Unit shall repair or replace the defective or non-conforming product or part without charge, whichever the G-R Unit chooses. You must have properly maintained and used the product or part claimed to be defective in accordance with the maintenance schedule or manual, which comes with the product. No allowance will be made for labor, installation, removal, transportation or other charges incurred by you in connection with such repair or replacement.
2. To obtain the above remedy:
 - A. Immediately notify the G-R Unit upon discovery of the claimed defect in materials or workmanship and provide the serial number or date code of the product and/or part(s) or provide the G-R Unit with the invoice or bill of sale referencing the product by no later than the expiration date of the warranty period.
 - B. The G-R Unit will advise whether inspection will be necessary and how whether repair or replacement will be made. If inspection by the G-R Unit is necessary, the pump or defective part must be sent freight pre-paid to the G-R Unit. Return shipment will be F.O.B. the G-R Unit's plant.
 - C. **Return Goods Authorization Requirement:** No product will be accepted for return or replacement without the prior written authorization of the G-R Unit. Upon such authorization, and in accordance with instructions from the G-R Unit, the product will be returned to the G-R Unit, shipping charges prepaid by the Buyer.
3. **Damages:** The G-R Unit's liability for damages for breach of this Limited Warranty shall not exceed the amount of the purchase price of the product or part(s) in respect to which Such damages are claimed. **IN NO EVENT SHALL THE G-R UNITS BE LIABLE FOR INCIDENTAL, CONSEQUENTIAL OR SPECIAL DAMAGES FOR BREACH OF THIS LIMITED WARRANTY.**
Some states do not allow the exclusion or limitation of incidental or consequential damages, so the above limitation or exclusion may not apply to you. This Limited Warranty gives you specific legal rights, and you may also have other rights, which vary from state to state.