

Please read and save this Repair Parts Manual. Read this manual and the General Operating Instructions carefully before attempting to assemble, install, operate or maintain the product described. Protect yourself and others by observing all safety information. The Safety Instructions are contained in the General Operating Instructions. Failure to comply with the safety instructions accompanying this product could result in personal injury and/or property damage! Retain instructions for future reference. AMT reserves the right to discontinue any model or change specifications at any time without incurring any obligation.

©2015 AMT Pump Company, A Subsidiary of The Gorman-Rupp Company, All Rights Reserved.



Periodic maintenance and inspection is required on all pumps to insure proper operation. Unit must be clear of debris and sediment. Inspect for leaks and loose bolts. Failure to do so voids warranty.

PumpCatalog.com

Questions? Call 1-800-810-1053

# 4-Inch Trash Pedestal Pump **AMT** A Gorman-Rupp Company

Refer to pump manual 1808-635-00 for General Operating and Safety Instructions.

## DESCRIPTION

This self-priming (to 20 ft. lift) centrifugal pump includes a clog resistant, open impeller capable of handling solids as large as 2" diameter (up to 25% by volume). A built-in check valve assists in priming and a mechanical seal prevents leakage. All seals are Buna N. Handles liquids from 40° to 180° F (4° to 82° C). For use with nonflammable liquids compatible with pump component materials.

## MAINTENANCE

### ▲ WARNING

To prevent accidental starting always remove the spark plug, or disconnect and ground the spark plug wire before attempting to service or remove any component.

## CLEANING

These units are designed so that for most cleanout or clogging problems it should not be necessary to remove hoses or piping. The suction area and impeller chambers can be reached by removing (2) threaded handles (Ref. No. 33) and removing suction cleanout cover plate (Ref. No. 31) and gasket (Ref. No. 30).

**NOTE:** When replacing cleanout cover plate, carefully wipe clean all surfaces on which gasket has contact. Also, make sure gasket is in position.

## MECHANICAL SEAL REPLACEMENT

Refer to Figures 1 and 2

**NOTE:** Always replace seal seat (Ref. No. 14), seal head (Ref. No. 15), and shaft sleeve (Ref. No. 16) to ensure proper mating of mechanical seal components!

1. Unthread fasteners (Ref. No. 28) and remove casing (Ref. No. 39) and casing seal (Ref. No. 13) from adapter (Ref. No. 12).
2. Unthread screws (Ref. No. 19) and remove volute (Ref. No. 20) from adapter.
3. Unscrew impeller (Ref. No. 18) from pump shaft (Ref. No. 5). Remove impeller shims (Ref. No. 17), shaft sleeve and seal head from pump shaft. Use a rubber mallet or soft block of wood to loosen impeller. Turn it counterclockwise.
4. Unthread fasteners (Ref. Nos. 7 & 8) and remove adapter from pedestal mounting face.
5. Push seal seat from adapter recess with a screwdriver.
6. Clean adapter recess before inserting a new seal seat.
7. Carefully wipe polished surface of new seal seat with a clean cloth.
8. Wet the rubber portion of seal seat with a light coating of soapy water.
9. Press new seal seat squarely into cavity in adapter. If seal seat does not press squarely into cavity, it can be adjusted in

place by pushing on it with a piece of pipe. Always use a piece of cardboard between pipe and seal seat to avoid scratching seal seat. (This is a lapped surface and must be handled very carefully.)

10. After seal seat is in place, ensure that it is clean and has not been marred.
11. Using a clean cloth, wipe shaft and make certain that it is perfectly clean.
12. Secure adapter on pedestal mounting face.
13. **NOTE:** Tighten fasteners EVENLY to avoid cracking rabbet on pedestal mounting face.
14. Apply a light coating of soapy water to the inside rubber portion of seal head and slide onto shaft sleeve. Slip shaft sleeve with seal head onto pump shaft.

**IMPORTANT:** Before installing new shaft sleeve, apply a bead of non-hardening, pliable sealant (such as Permatex® Form-A-Gasket® No. 2) to motor shaft shoulder.

14. Replace any impeller shim removed in disassembly.
15. Screw impeller back in place tightening until it is seated against shims and shaft sleeve.
16. Remount volute with fasteners.
17. Refer to section entitled "Shim Adjustment" at this time if shaft sleeve or any other parts listed therein have been replaced.
18. Inspect position of flapper valve assembly (Ref. No. 23) to insure proper movement and seating.
19. Replace casing seal on volute rabbet.

**NOTE:** Always inspect casing seal. Replace when cracked or worn. Wet casing seal with soapy water for ease of assembly.

20. Remount casing.
21. Remount any other parts and reconnect spark plug wire. Pump should now run with renewed original performance.

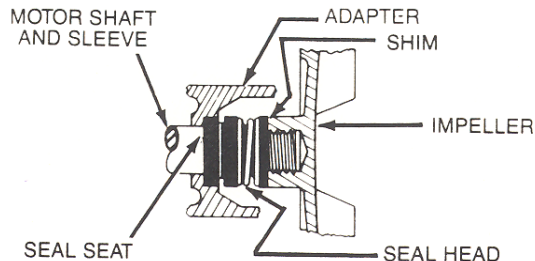

Figure 1 – Mechanical Seal

## Performance Chart

| HP | Power Req.<br>RPM | GPM at Total Head in Feet |     |     |     |     |     |     |     |     |      |      | Max**<br>Head |
|----|-------------------|---------------------------|-----|-----|-----|-----|-----|-----|-----|-----|------|------|---------------|
|    |                   | 10'                       | 20' | 30' | 40' | 50' | 60' | 70' | 80' | 90' | 100' | 110' |               |
| 15 | 3600              | 630                       | 600 | 560 | 520 | 475 | 425 | 370 | 310 | 240 | 170  | 85   | 120 ft.       |

(\*\*) Shut-off; to convert to psi, divide by 2.31.

# 4-Inch Trash Pedestal Pump

## IMPELLER AND VOLUTE REPLACEMENT

Impeller (Ref. No. 18) and volute (Ref. No. 20) are subject to wear only by abrasive sand or sediment laden liquids. If badly worn, all these parts can be replaced easily and pump thus restored to full efficiency.

**NOTE:** When clearance between impeller and volute exceeds 1/16" at face of impeller or 1/8" on outside diameter of impeller, it may be necessary to take corrective action. The increased clearance can cause lengthened priming and decreased capacity to your unit. If performance is satisfactory for your application, it is recommended that no corrective maintenance be performed regardless of what clearances on your unit may have developed. This is because increased clearances in themselves are not generally harmful to your pump. Normally, new pump clearances can be restored by simply shimming behind impeller. (Add shim washers Ref. No. 17). If impeller is badly worn it is recommended that impeller be replaced. This is usually all that is required since only on usually abrasive surfaces does the cast iron wear plate show deterioration. Occasionally a stone or hard object might get caught in impeller and cause damage to volute/cut-water. In these cases, follow instructions below for replacement and refer to Figure 1.

1. Disassemble pump for access as described in Mechanical Seal Replacement, steps 1 and 2.
2. Replace parts as necessary.

**NOTE:** When replacing volute, attach flapper valve assembly (Ref. No. 23) to new volute with fastener (Ref. No. 24).

**NOTE:** Before installing new parts, clean all mating surfaces thoroughly.

## BEARING HOUSING SERVICE

1. Remove front pump assembly as described under "Mechanical Seal Replacement"
2. Remove shaft bearing (Ref. No. 3) and shaft (Ref. No. 5) as an assembly by first removing retaining ring (Ref. No. 1). Push shaft bearing assembly out of pedestal (Ref. No. 6) by rapping on threaded end of shaft with a rawhide mallet, or block of wood and a hammer.
3. Ball bearings can now be removed from shaft.
4. If shaft bearings have been removed from shaft, replace by sliding bearing on shaft to shoulder. Replace shaft bearing assembly by sliding assembly into housing threaded end first. Push shaft bearing assembly completely in by gently tapping on keyway end of shaft with a rawhide mallet. Replace retaining ring.
5. Reassemble pump as described in "Mechanical Seal Replacement".

## SHIM ADJUSTMENT

1. When installing a replacement adapter (Ref. No.12), impeller (Ref. No. 18), shaft sleeve (Ref. No. 16), volute (Ref. No. 20) or casing (Ref. No. 39) it may be necessary to vary the number of impeller shims (Ref. No. 17) that will be required. This is easily done by adding one shim more than was removed and reassembling pump as described in "Mechanical Seal Replacement" section.

**NOTE:** When adding or removing shims, it is best to proceed with a 0.010" increment each time. While tightening unit together turn shaft; feel for shaft seizing. If shaft begins to seize before fasteners are completely tight, disassemble pump and remove one shim and repeat assembly.

2. Once having added one shim more than original, ensure that volute and adapter are firmly fitted (check fasteners Ref. No. 19). When pump shaft turns freely add shims until it does strike, then remove a 0.010" shim. This should allow proper clearance.

3. Proper running clearance for impeller should be as close as possible to volute without striking; maximum clearance is 1/32" (0.032").

4. Follow above procedure until proper clearance is obtained. This will ensure maximum performance.

## ***For Repair Parts contact dealer where pump was purchased.***

*Please provide following information:*

-Model Number

-Serial Number (if any)

Part description and number as shown in parts list

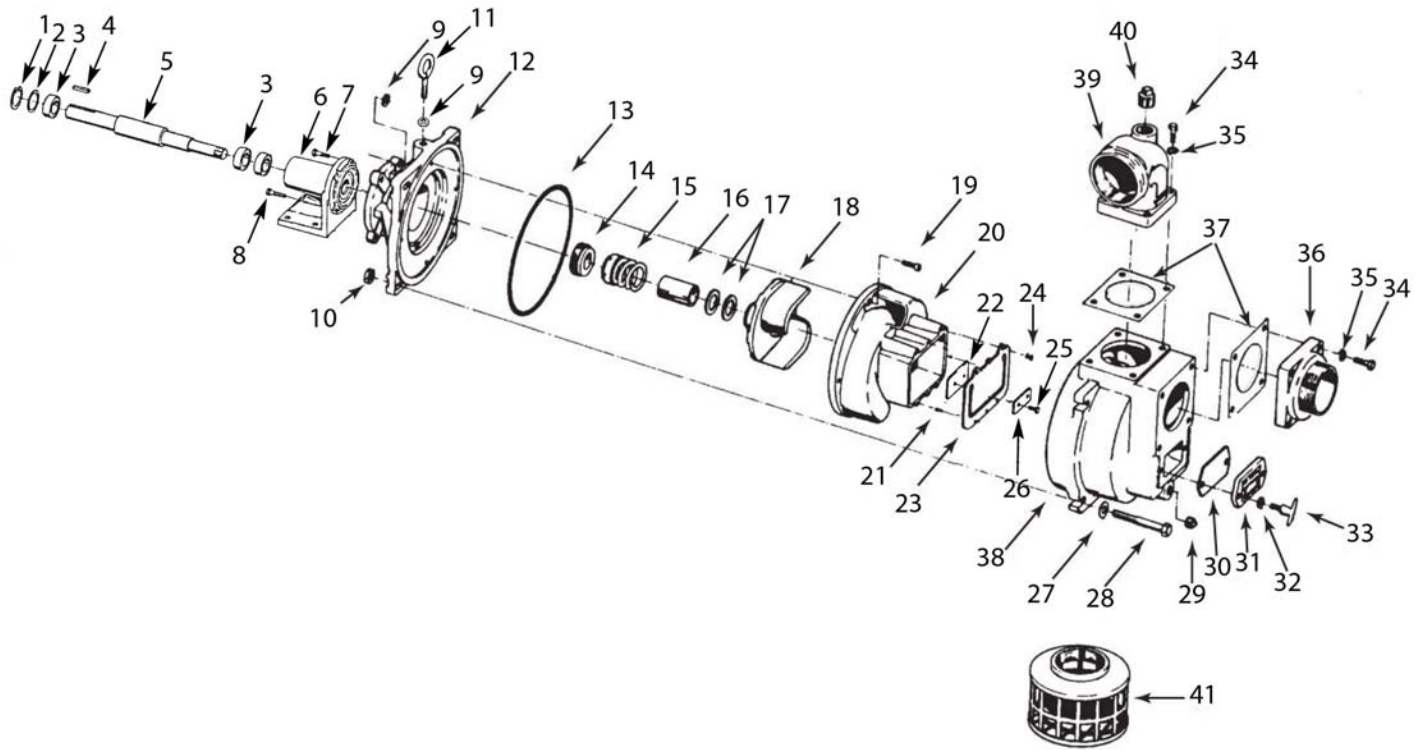

**Figure 2 – Repair Parts Illustration**

## Repair Parts List

| Ref. No. | Description   | Part Number    | Qty. |
|----------|---|----------------|------|
| 1        | Retaining Ring  | 1695-057-00    | 1    |
| 2        | Bearing Shim Set  | 1695-020-90    | 1    |
| 3        | Ball Bearing  | 1695-056-00    | 3    |
| 4        | Key   | 1695-039-00    | 1    |
| 5        | Shaft   | 1695-060-00    | 1    |
| 6        | Pedestal  | 1695-054-01    | 1    |
| 7        | Fastener  | *              | 2    |
| 8        | Fastener  | *              | 2    |
| 9        | Nut   | *              | 5    |
| 10       | Nut   | *              | 4    |
| 11       | Eyebolt   | 2169-000-00    | 1    |
| 12       | Adapter   | 2184-001-02    | 1    |
| 13       | O-Ring #276 - Buna N                                      | 2185-000-00    | 1    |
| 14&15    | Shaft Sleeve Assembly - Viton & Silicon Carbide           | 1640-167-90    | 1    |
| 16       | Shaft Sleeve  | 1555-140-03    | 1    |
| 17       | Impeller Shim Set   | 1656-000-90    | 1    |
| 18       | Impeller  | 3945-012-04    | 1    |
| 19       | Fastener  | *              | 2    |
| 20       | Volute  | 1990-002-01    | 1    |
| 21       | Retainer Pin  | 2121-000-00    | 4    |
| 22       | Rear Flapper Weight                                       | Incl. w/Ref 23 | 1    |
| 23       | Flapper Assembly<br>(includes Ref. Nos. 22, 23, and 26)   | 1696-033-90    | 1    |
| 24       | Fastener  | *              | 2    |
| 25       | Fastener  | *              | 2    |
| 26       | Front Flapper Weight                                      | Incl. w/Ref 23 | 1    |
| 27       | Washer  | *              | 4    |
| 28       | Fastener  | *              | 4    |
| 29       | Pipe Plug   | *              | 1    |
| 30       | Cleanout Gasket   | 2115-003-00    | 1    |
| 31       | Cleanout Plate  | 2115-002-01    | 1    |
| 32       | Washer  | *              | 2    |
| 33       | Cleanout Handle   | 1601-000-00    | 2    |
| 34       | Fastener  | *              | 8    |
| 35       | Washer  | *              | 8    |
| 36       | Suction Plate Kit<br>(includes Ref. Nos. 34, 35, and 36)  | 3993-050-95    | 1    |
| 37       | Gasket Kit (includes 2 gaskets)                           | 3993-071-90    | 1    |
| 38       | Casing  | 2116-001-01    | 1    |
| 39       | Discharge Manifold<br>(includes Ref. Nos. 34, 35, and 39) | 3993-080-95    | 1    |
| 40       | Pipe Plug   | *              | 1    |
| 41       | Suction Strainer  | 1681-001-00    | 1    |

(\*) Standard Hardware Item, Available Locally

Order Online: [www.PumpCatalog.com](http://www.PumpCatalog.com)







AMT Pump Company  
(herein "AMT")  
400 Spring Street  
Royersford, PA 19468  
Phone: (610) 948-3800  
Fax: (610) 948-5300  
www.amtpump.com



## General Information

**SALES POLICY:** AMT products are sold through our established Distributors. We do not sell direct to the consumer or organization not entitled to trade recognition. Therefore, possession of our catalogs and/or price list(s) does not infer an offer to sell.

**MINIMUM ORDER:** We appreciate your order, however, all orders are subject to a minimum \$35.00 net invoice charge (excluding freight). This applies to all pump and parts purchase orders.

**PRICES:** Prices are subject to change without notice. All orders accepted are subject to prices in effect at time of shipment.

**PAYMENT TERMS:** Terms, upon establishment of credit, are Net 30 days. Past due accounts may be subject to a service charge of 1.5% per month. Domestic or assignable letter of credit is required for all export trade.

**PAST DUE ACCOUNTS:** AMT reserves the right to withhold open account shipments on any past due account. Invoices are considered past due after thirty (30) days. In the interest of sound business, all orders are subject to approval of the Credit Department.

**SHIPPING INSTRUCTIONS:** All shipments will be made F.O.B. the factory. Where instructions for shipment do not appear on the order, the shipment will be made according to our best judgment. Full risk of loss (including transportation delays and losses) shall pass to the customer upon delivery of the products to the carrier at the F.O.B. point. When loss or delay occurs, primary responsibility for tracing rests with the customer. When there is LOSS or APPARENT VISIBLE DAMAGE to a shipment, when tendered for delivery, **DO NOT** give the carrier a clear receipt. Note such damage on the carrier's delivery receipt and **HAVE THE DRIVER SIGN THE RECEIPT.**

**PRODUCT REVISIONS:** AMT reserves the right to discontinue, change or improve its products or any portions thereof without being obligated to provide such a change or improvement for units sold and/or shipped prior to such a change or improvement.

**LEAD TIME:** Products designated "Quick Ship Product", also referred to as "QSP" will normally be shipped within 24 hours of receipt of a non-cancellable purchase order. Only limited quantities of "QSP" pumps are available.

**STANDARD LEAD TIME:** Lead time is two weeks for all non "QSP" product. AMT reserves the right to revise lead times as required due to availability of materials and all other causes beyond our control.

**VIP SHIPMENT:** Select AMT and IPT branded pumps are available for next day shipment for non-QSP (Quick Ship Products) items and subjected to a specific model surcharge per unit noted in the respective price book. Requires calling for availability, confirmation and a non-cancellable purchase order or credit card payment prior to shipment. The expedited shipping charges are an additional cost added separately from the VIP charges per item. AMT reserves the right to revise lead times as required due to availability of materials and all other causes beyond our control. QSP quantities are limited as determined by AMT.

ALL purchase orders must be submitted via hard copy sent to AMT customer service department by fax, EDI or e-mail.

**RETURN GOODS POLICY:** Goods shall not be returned without a return goods authorization number (RGA) issued by AMT customer service. The RGA number must be listed on the packing list. Only current model and part numbers with a valid date code may be returned (within one year from date of purchase). **A 20% restocking and packaging charge will apply to all returns. All shipping charges must be pre-paid. No exceptions.**

**ORDER CHANGES BY CUSTOMER:** Orders in process may not be changed except with written consent and may be subject to special charges.

## 12 Month Limited Warranty

### EXTENT AND DURATION OF LIMITED WARRANTY

**Coverage:** AMT Pump Company (herein "AMT") or IPT Pumps by Gorman-Rupp (herein "IPT") or Gorman-Rupp Industries Division of The Gorman-Rupp Company, Patterson, or the Gorman-Rupp Company (herein referred to as "G-R Unit") each individually warrants that its products and parts shall be free from defects in material and workmanship for twelve (12) months from the date of purchase by the original end user when installation is made and maintenance is performed in accordance with G-R Unit's recommendations. Wear and tear resulting from use and items normally consumed in use are not covered.

### EXCEPTIONS

( A ) This Limited Warranty shall not apply to mechanical seals in AMT or IPT pumps and the following products and parts: engines, motors, trade accessories and all other products, components, parts and materials not manufactured by the G-R Units. These items may, however, be covered by the warranties of their respective manufacturers. ( B ) This warranty does not extend to or apply to any unit which has been repaired or altered at any place other than by a G-R Unit, or by persons not expressly approved by a G-R Unit to make repairs or alterations, nor to any unit the serial number, model number or identification of which has been removed, defaced or altered. ( C ) This warranty does not extend to any product manufactured by a G-R Unit, which has been subjected to mis-use, neglect, accident, improper installation, or use in violation of instructions furnished by a G-R Unit. ( D ) Pump Kits: This warranty does not extend to any product sold by a G-R Unit unassembled as a Pump Kit. Pump Kits are warranted against defects in material and workmanship for 60 days from the date of shipment from a G-R Unit. Any Pump Kit parts deemed defective by a G-R Unit will be replaced free of charge within 60 days of shipment. Pump Kits are not returnable for credit.

### LIMITATIONS

**THE G-R UNITS' SOLE AND EXCLUSIVE WARRANTY WITH RESPECT TO THEIR PRODUCTS AND PARTS IS THIS LIMITED WARRANTY. THIS LIMITED WARRANTY IS IN LIEU OF ALL OTHER EXPRESS AND/OR IMPLIED WARRANTIES, INCLUDING IMPLIED WARRANTIES OF MERCHANTABILITY AND FITNESS FOR PARTICULAR PURPOSE.**

### EXCLUSIVE REMEDY AND DAMAGES

The sole and exclusive remedy for breach of this Warranty by a G-R Unit and the entire extent of its liability for such breach or for damages arising from the use of the products and parts covered under this Limited Warranty, shall be as follows:

- Repair or Replacement:** If inspection shows that any G-R Unit product or part covered under this Limited Warranty is defective in materials or workmanship, the G-R Unit shall repair or replace the defective or non-conforming product or part without charge, whichever the G-R Unit chooses. You must have properly maintained and used the product or part claimed to be defective in accordance with the maintenance schedule or manual, which comes with the product. No allowance will be made for labor, installation, removal, transportation or other charges incurred by you in connection with such repair or replacement.
- To obtain the above remedy:
  - Immediately notify the G-R Unit upon discovery of the claimed defect in materials or workmanship and provide the serial number or date code of the product and/or part(s) or provide the G-R Unit with the invoice or bill of sale referencing the product by no later than the expiration date of the warranty period.
  - The G-R Unit will advise whether inspection will be necessary and how whether repair or replacement will be made. If inspection by the G-R Unit is necessary, the pump or defective part must be sent freight pre-paid to the G-R Unit. Return shipment will be F.O.B. the G-R Unit's plant.
  - Return Goods Authorization Requirement:** No product will be accepted for return or replacement without the prior written authorization of the G-R Unit. Upon such authorization, and in accordance with instructions from the G-R Unit, the product will be returned to the G-R Unit, shipping charges prepaid by the Buyer.
- Damages:** The G-R Unit's liability for damages for breach of this Limited Warranty shall not exceed the amount of the purchase price of the product or part(s) in respect to which Such damages are claimed. **IN NO EVENT SHALL THE G-R UNITS BE LIABLE FOR INCIDENTAL, CONSEQUENTIAL OR SPECIAL DAMAGES FOR BREACH OF THIS LIMITED WARRANTY.**

Some states do not allow the exclusion or limitation of incidental or consequential damages, so the above limitation or exclusion may not apply to you. This Limited Warranty gives you specific legal rights, and you may also have other rights, which vary from state to state.



**A Gorman-Rupp Company**



**BY**

**GORMAN-RUPP®**

[www.amtpump.com](http://www.amtpump.com)