

Please read and save this Repair Parts Manual. Read this manual and the General Operating Instructions carefully before attempting to assemble, install, operate or maintain the product described. Protect yourself and others by observing all safety information. The Safety Instructions are contained in the General Operating Instructions. Failure to comply with the safety instructions accompanying this product could result in personal injury and/or property damage! Retain instructions for future reference. AMT reserves the right to discontinue any model or change specifications at any time without incurring any obligation.

©2017 AMT Pump Company, A Subsidiary of The Gorman-Rupp Company, All Rights Reserved.

Periodic maintenance and inspection is required on all pumps to ensure proper operation. Unit must be clear of debris and sediment. Inspect for leaks and loose bolts. Failure to do so voids warranty.

25FP Fire Pump Series



Refer to form 1808-633-00 for General Operating and Safety Instructions.

DESCRIPTION

This is a single-stage centrifugal pump designed for agriculture or fire fighting service. It is close coupled to an internal combustion air cooled engine and protected by a roll frame equipped with four carry handles. The pump is compact and light-weight, designed for portability. Pump construction is rugged and allows for easy maintenance.

Units are designed to handle clean water or water containing small (1/16" maximum spherical diameter) solids. Suction and discharge ports are 2-1/2" NPT threaded. Discharge includes a built in bronze check valve to allow use of an exhaust or hand operated priming system.

Liquid temperature range is 40°F to 180° F (4°C to 82°C). Maximum casing pressure is 180 psi (1240 kPa). For use with nonflammable liquids that are chemically compatible with pump component materials.

SPECIFICATIONS

Suction inlet.....	2-1/2" NPT Female
Discharge outlet.....	2-1/2" NPT Female
Dimensions overall (Length x Width x Height)	
25FP13AR & 25FP13HR.....	(32" x 32" x 25")
25FP23AR.....	(41" x 32" x 25")
Engine and fuel tank size	
25FP13AR.....	B&S Vanguard 13HP
25FP13HR.....	Honda GX390
25FP23AR.....	B&S Vanguard 23HP
25FP13ZR.....	Hatz 1B50
25FP10YR.....	Yanmar L100

BASIC CONSTRUCTION

Pump is constructed of cast aluminum. Engine shaft is sealed with a self-lubricating mechanical seal that consists of a silicon carbide stationary ring, carbon rotating head, stainless steel spring and Viton® elastomer. Discharge flange gasket and casing o-ring are Viton®.

UNPACKING

Refer to repair parts illustration and parts list to aid in identifying pump components. Unpack and separate all pump components from shipping/packaging materials, making sure all parts are accounted for. Retain all manuals for future reference.

Package should contain:

- Pump/engine completely assembled and mounted in roll frame.
- Rubber feet with fasteners bag.
- Frame handle parts bag.
- Frame panel and parts bag.
- Engine owner's manual
- Pump general safety manual,
- Specifications information and repair parts manual.

ASSEMBLY

Roll Frame Handle Assembly:

1. Install pivot bearing (A6) in frame hole. Ends of bearing must be flush with outside of frame rail.
2. Hold handle (A3) perpendicular to frame tube.
3. Slide handle end ears over frame tube until handle tube end contacts frame.
4. Align handle ear hole with bearing in frame.
5. Install pivot pin (A5) and pin end cotter (A7).
6. Install lock pin (A4) in other handle ear hole. Secure with cotter (A7).
7. Handle can be locked in the up or down position with lock pin.
8. Repeat procedure for [3] three remaining handles.

Roll Frame Panel Assembly:

1. Slide panel mounting brackets (A10) over frame tube where panel will be positioned.
2. Align slots in end of panel (A9) with holes in mounting brackets.
3. Fasten panel to brackets with bolts (A11) and nuts (A12) provided.

Rubber Feet Assembly:

1. Install bolt (A20) through rubber foot (A19) center hole.
2. Slide bolt through hole provided in lower tube of roll frame.
3. Fix in position with nut (A21).
4. Repeat for [3] three remaining feet.

Battery Tray Assembly:

1. Locate battery tray (A14) on frame rail.
2. Install mounting bolts (A15) with washers (A16), and nuts (A17).
3. Install "J" bolts in tray slots.
4. Install hold down angle on "J" bolt threaded ends, fix with wing nuts.

Install Battery:

1. Maximum battery size is 5-1/4" wide X 7-3/4" long, 230 CCA (Cold Cranking Amps) or greater U1/U1R Lawn and Garden battery.
2. Position battery in tray with (+) terminal towards engine end of frame and (-) battery terminal towards pump end of frame.
3. Hold battery in position with hold down angle, "J" bolts, and wing nuts.
4. Connect engine starter red cable to battery (+) terminal and ground black cable to (-) terminal with fasteners (not provided).

25FP Fire Pump Series

Fuel Tank Frame Assembly: [25FP23AR]

1. Position fuel tank frame (A32) on roll frame.
2. Align holes in tank frame ears with holes in roll frame tubes and cross member.
3. Install mounting bolts (A33 & A34) and nuts (A35) securing tank frame to roll frame.
4. Install fuel line from bottom of tank to fuel pump on engine with hose clamp provided.
5. Install purge line from top of tank to engine purge line with connector and hose clamp.

INSTALLATION

Review all safety information located in pump safety manual.

Follow the instructions on all tags, labels and decals attached to the pump.

Since pump installations are seldom identical, this section offers only general recommendations and practices required to inspect, position and arrange the pump and piping.

Most of the information pertains to a standard static lift application where the pump is positioned above the free level of liquid to be pumped.

If installing in a flooded suction application where the liquid is supplied to the pump by gravity or under pressure, some of the information such as mounting, line configuration and priming must be tailored to the specific application. Be sure to limit the incoming pressure if required, so the maximum casing pressure does not exceed 180 psi (1240 kPa).

Pre-Installation Inspection

The pump assembly was inspected before shipment from the factory. Before installation, inspect the pump for damage, which may have occurred during shipment or in storage. Check as follows:

- Inspect pump casing for cracks, dents, damaged threads and other obvious damage.
- Check for and tighten any loose fasteners.
- Carefully read all hang tags, labels and markings on the unit. Follow the instructions indicated.
- Check oil level in engine. Follow manufacturer's recommendations listed in engine manual.
- If unit has been stored for more than 12 months, replace engine oil. Drain any fuel and replace with fresh fuel.
- Check condition of suction strainer, clean if clogged with debris.

Positioning Pump

This pump is light-weight. Pump/engine is mounted in a roll frame that has (4) four lifting handles built in. Handle has (2) two pins installed. The pivot pin goes through handle end plates and directly through frame tube. Second is the lock pin, it goes through handle end plates only.

To raise and lower handles:

- Remove cotter from lock pin end.
- Remove lock pin.
- Swing handle tube up perpendicular to frame tube.
- Install lock pin, fix with cotter.
- To lower handle remove lock pin, swing handle down, reinstall lock pin

Lift and carry pump/engine/battery only with handles. Remove suction and discharge lines and all accessories from pump before lifting.

Mounting

Locate the pump in an accessible area as close as practical to the liquid being pumped.

Pump should be leveled if possible by shimming under rubber feet. For proper pump/engine operation unit should be within 15° of level. Continuous operation outside this limit may cause engine/pump damage.

System Piping/Hose

Flow through the system is reduced by increased suction lift, increased discharge elevation or discharge nozzle pressure and increased friction losses.

- Keep suction and discharge lines as short and direct as possible to reduce friction losses. If elbows are necessary in discharge line, use long-radius type, when possible.
- Do not operate with coiled-up suction or discharge hose.
- Do not use valves in the suction line, unless absolutely necessary.

Suction Lines

The suction line must be as short and direct as possible. When operating pump under a suction lift condition:

- To avoid air pockets which could affect pump priming, the line must always slope upward to the pump from the liquid source. If the line slopes down at any point along the suction run air pockets will be created.
- Hose or pipe size must match pump suction size.
- The maximum vertical lift cannot exceed 20 feet (6.1 meters).
- If hose is used for the suction line, it must be the rigid wall reinforced type to prevent collapse under suction.
- Fittings are not recommended in the suction line.

Strainers

Use a suction strainer with ¼" maximum diameter holes on end of suction line. A suction strainer will help remove large solids that could clog the pump impeller and casing.

Discharge Lines

Use hose or piping that is rated above the maximum system line pressure.

To reduce friction head, keep line as short and direct as possible. Make minimum use of elbows and fittings, since those two items substantially increase friction loss in the discharge line.

Do not terminate the discharge line at a level lower than that of the liquid being pumped unless a siphon breaker is used in the line. Otherwise, a siphoning action causing damage to the pump could result.

Valves

A check valve in the discharge is normally recommended, but it is not necessary in low discharge head applications.

If a throttling valve is desired in the discharge line, use a valve as large as the largest pipe to minimize friction losses. Never install a throttling valve in the suction.

With high discharge heads, it is recommended that a throttling valve and a system check valve be installed in the discharge line to protect the pump from excessive shock pressure and reverse rotation when it is stopped.

25FP Fire Pump Series

Connections to Pump

Since even a slight leak will affect priming, head and capacity, especially when operating with a high suction lift, all threaded connections in the suction line must be sealed with pipe sealant to ensure an air tight seal. Check all hose connection gaskets; replace any that are cracked, worn or no longer elastic.

Suction Lines in Sumps/Pits

If a single suction line is installed in a sump, it should be positioned away from the wall of the sump at a distance equal to 1-1/2 times the diameter of the suction line.

If there is a liquid flow from an open pipe into the sump, the flow should be kept away from the suction inlet because the inflow will carry air down into the sump and air entering the suction line will reduce pump efficiency.

If it is necessary to position the inflow close to the suction inlet, install a baffle between the inflow and the suction inlet at a distance 1-1/2 times the diameter of the suction line.

Suction Line Positioning

The depth of the suction line is critical to efficient pump operation. Make certain end of suction line is far enough under the liquid surface. If a vortex is noticed at suction line end, submerge end deeper.

OPERATION

Review all SAFETY information in the pump General Safety Manual.

Follow the instructions on all tags, labels and decals attached to the pump.

Priming

Install the pump and piping as described in INSTALLATION section of this manual. Make sure that all connections are air tight and the pump is positioned level on a solid foundation.

Since this pump is not self-priming, it is equipped with either an exhaust primer or a hand operated diaphragm priming pump.

Exhaust Primer

The exhaust primer utilizes engine exhaust gases directed through a venturi to create a vacuum and draw air out of the suction line and pump casing.

The exhaust primer is capable of priming a pump with a maximum priming lift of 19 feet (5.79 meters). If the pump does not prime in a reasonable length of time, check the suction line for leaks.

To prime the pump with the exhaust primer:

- Close the exhaust primer handle (C4) and open ball valve (B32) in pump suction vacuum line.

NOTE: It may be required to apply a coating of grease/lubricant on the outer portion of the valve cap (C3) for a better seal to reduce priming time.

- Start the engine according to engine manufacturer instructions.
- Operate the engine at maximum throttle speed and allow primer to remove air from suction until liquid flows from primer ejector (C7).
- When the pump is fully primed, close the vacuum line valve and release the exhaust primer handle.

Hand Primer

The hand primer is a positive displacement diaphragm pump. Hand priming pump is mounted directly to roll frame on a bracket (A37) that includes a pocket to hold the primer handle (C27). Priming relies on the operator manually stroking the handle to remove the air from the suction line and pump casing. To prime the pump with the hand primer:

- Remove priming pump handle from bracket and install in priming pump.
- Open ball valve (B32) in pump suction vacuum line.
- Operate pump handle up and down until pump casing is full of liquid and water starts to enter the priming pump.
- When the pump is fully primed, close the vacuum line valve.
- Start the engine according to engine manufacturer's instructions.

Once fully primed, reduce engine speed slightly and slowly open the discharge throttling valve. The discharge line should be filled slowly to prevent damage to the piping, hose or gaskets. When the discharge line is completely filled, adjust the discharge throttling valve and engine speed until desired operating point is reached.

Leakage

No leakage should be visible at pump mating surfaces or at pump connections or fittings. Keep all line connections and fittings tight to maintain maximum pump efficiency.

Liquid Temperature and Overheating

The maximum liquid temperature for the pump is 180°F (82°C). Do not apply it at a higher operating temperature than is recommended.

Overheating can occur if operated with a closed valve in the discharge (valves should not be installed in suction line). Operating against a closed valve could bring the liquid to a boil, build pressure and cause the pump to rupture or explode. If overheating occurs, stop the pump and allow it to completely cool before servicing it. Refill the pump casing with cool liquid.

▲ WARNING

Do not remove plates, covers, gauges, pipe plugs or fittings from an overheated pump. Vapor pressure within the pump can cause parts being disengaged to be ejected with great force. Allow the pump to completely cool before servicing.

Strainer Check

Check the suction strainer regularly and clean it as necessary. The strainer should also be checked if pump flow rate begins to drop. If a suction vacuum gauge has been installed, monitor and record the readings regularly to detect strainer blockage. Vacuum reading will increase at a given flow rate if strainer becomes blocked.

Never introduce air, steam or high water pressure into the casing to remove blockage in suction line or strainer. This could result in personal injury or damage to the equipment.

Stopping

Never halt the flow of liquid suddenly. If the liquid being pumped is stopped abruptly, damaging shock waves can be transmitted to the pump and piping system. Close all valves slowly.

If the application involves a high static discharge head, gradually close the discharge throttling valve before stopping the pump. The pump discharge check valve may be damaged if liquid in the discharge piping suddenly reverses direction when the engine is stopped.

Cold Weather Preservation

In below freezing conditions, completely drain the pump and piping system to prevent damage from freezing. If the pump will sit idle for more than a few hours, remove the casing and make certain all liquid has been drained. Clean any solids from casing.

25FP Fire Pump Series

MAINTENANCE

Preventative Maintenance

Since pump applications are seldom identical and pump wear is directly affected by such things as the abrasive qualities, pressure and temperature of the liquid being pumped, this section is intended only to provide general recommendations and practices for preventive maintenance. Regardless of the application, following a routine preventive maintenance schedule will help assure trouble free performance and long life from your pump.

Record keeping is an essential component of a good preventive maintenance program. Changes in suction and discharge gauge readings (if so equipped) between regularly scheduled inspections can indicate problems that can be corrected before system damage or catastrophic failure occurs. The appearance of wearing parts should also be documented at each inspection for comparison as well. Also, if records indicate that a certain part (such as the shaft seal) fails at approximately the same duty cycle, the part can be checked and replaced before failure occurs, reducing the unscheduled down time. For new applications, a first inspection of wearing parts at 250 hours will give insight into the wear rate for your particular application. Subsequent inspections should be performed at regular intervals. Critical applications should be inspected more frequently.

- General condition (temperature, unusual noises or vibrations, cracks, leaks, loose hardware, etc)...DAILY
- Pump performance (gauges, speed, flow)...DAILY
- Impeller wear rings (excessive wear, poor performance)...SEMI-ANNUALLY 25FP Fire Pump Series
- Mechanical shaft seal (excessive wear, heat damage, leakage, etc)...SEMI-ANNUALLY
- Discharge check valve/gasket (excessive wear)...SEMI-ANNUALLY
- Engine lubrication – See Engine Manufacturer's Service Manual. Inspect, clean, and replace components as needed.

PUMP/SEAL DISASSEMBLY & REASSEMBLY

Review all SAFETY information provided in this manual and pump General Safety Manual.

Follow the instructions on all tags, labels and decals attached to the pump.

This pump requires little service. When it becomes necessary to inspect or replace the wearing parts, follow these instructions that are keyed to the repair part lists and repair part explosions.

This manual will alert personnel to known procedures that require special attention, could damage equipment or be dangerous to personnel. However, this manual cannot possibly anticipate and provide detailed precautions for every situation that might occur during maintenance of the unit. Therefore, it is the responsibility of the owner/maintenance personnel to ensure that only safe, established shop procedures are used and that any procedures not addressed in this manual are performed only after establishing that neither personal safety nor pump integrity are compromised by such practices.

▲ WARNING

Before attempting to service the pump, switch off the engine ignition and remove the spark plug or take other precautions to ensure that it will remain inoperative. Close all valves in the discharge lines.

Before attempting to service the pump:

- Familiarize yourself with this manual.
- Shut down the engine and remove the spark plug wires to ensure that the pump will remain inoperative.
- Allow the pump to completely cool if overheated.
- Check the temperature before opening any covers, plates or plugs.
- Close the discharge valve.
- Vent the pump slowly and cautiously.
- Drain the pump.

For engine disassembly and repair, consult the literature supplied with the engine or contact your local engine service representative.

PUMP DISASSEMBLY

First Step:

1. Disconnect the priming vacuum hose (C31) female SAE fitting (C34) from the male SAE fitting (B33) installed in the ball valve (B32).
2. Remove the casing drain plug (B9) and drain the pump casing. Clean and reinstall the plug.

Remove Casing:

For access to the impeller (B15) and shaft seal assembly (B19 & B20):

1. Remove the nuts (B12) securing the pump casing (B8) to the intermediate (B3).
2. Remove the casing from the intermediate.
3. Remove the casing o-ring (B21) and clean all mating surfaces.

Inspect the casing wear ring/inlet (B13) for excessive wear or damage. The wear ring is secured in the casing with a press fit. If replacement is required, remove existing worn ring and replace with a new replacement ring. Be careful not to damage the casing ring bore when removing existing ring.

Remove Discharge Check Valve Body:

1. Remove the nuts (B27) and separate the check valve body (B24) from the pump casing.
2. Pull the flange gasket (B22) from the flange studs (B26) and pull the check valve arm (B25) from the check valve body.

Clean the mating surfaces of both flanges and inspect all parts for wear or damage.

Remove Impeller:

To remove the impeller (B15):

1. Insert a steel bar or drift pin between the vanes and turn the impeller in a counter-clockwise direction (when facing the impeller) while holding the engine crankshaft stationary. Be careful not to damage the impeller vanes.

Seal Removal and Disassembly:

1. Remove the impeller shims if so equipped, not all pumps will require shims. Tie and tag the shims or measure and record their thickness for ease of reassembly.
2. Remove the seal spring and then slide the shaft sleeve (B16) and rotating portion (B19) of the seal off the engine shaft as a unit.
3. Slide the rotating portion of the seal off the sleeve.
4. Remove the stationary seal ring (B20) from the intermediate, see following section.

25FP Fire Pump Series

Remove Intermediate:

1. Remove the nuts (B5) holding the intermediate (B3) to the engine (B1). Remove the intermediate from the engine.

Inspect the balance ring (B6) if so equipped for excessive wear or damage. The balance ring is secured in the intermediate by a press fit. If replacement is required remove existing worn ring and replace by pressing in a new ring. Use Loctite® or similar thread-locker in bore before pressing in new ring. Be careful not to damage the intermediate ring bore when removing existing ring.

Remove and Disassemble Exhaust Primer:

[25FP23AR & 25FP13AR]

1. Remove vacuum hose (C32) female SAE swivel fitting (C34) from male SAE fitting (B33) installed in casing vacuum ball valve (B32).
2. Remove the vacuum hose NPT fitting (C33) from the ejector body (C5).
3. Remove the ejector jet (C7) from ejector body.
4. Remove the ejector body from the venturi (C6).
5. Remove the venturi from the valve body (C2).

NOTE: All parts unthread counterclockwise. Clean any deposits or build-up on the parts.

6. To remove the valve body unthread from muffler outlet [25FP23] or loosen clamp (C11) [25FP13AR] and slide connecting nipple (C10) off of muffler outlet.

Remove and Disassemble Hand Primer:

The hand primer (C12) [25FP13HR] is a complete unit that requires little maintenance.

1. Remove vacuum hose (C31) female SAE swivel fitting (C34) from male SAE fitting (B33) installed in casing vacuum ball valve (B32).
2. To remove hand primer assembly from mounting bracket (A37) remove mounting screws (A41). Separate hand primer from mounting bracket.
3. Remove bolts (C21) and nuts (C22) holding pump body together.
4. Separate lower half (C14) of pump body from upper half (C13).
5. Remove diaphragm (C15) if needed by removing fastener (C17) holding diaphragm to plunger rod (C23).
6. Remove street elbow (C29) reducing bushing (C28) and check ball seat bushing (C18) to inspect and/or replace check ball (C16).

PUMP REASSEMBLY

Seal Reassembly and Installation:

The seal is not normally reused because wear patterns on the finished faces cannot be realigned during reassembly. This could result in premature failure. Reuse an old seal only in an emergency situation.

Never mix old and new seal parts. Always replace the shaft seal as a complete unit.

Handle the seal parts with extreme care to avoid damage to precision lapped sealing faces.

Clean the shaft sleeve or replace it if there are cuts or nicks on either end.

Remove replacement seal from its packaging and inspect the precision finished faces to ensure that they are free of any foreign matter. Remove seal spring retainer, if so equipped. In this pump, the seal spring is centered on the impeller hub. The spring retainer supplied with the replacement seal is not needed.

To ease installation of the seal; lubricate the rotating element rubber bellows and the stationary ring o-ring with soapy water.

1. Install the stationary ring into its bore in the intermediate. Use thumb pressure to press the ring in until it is fully seated. Be careful not to damage the seal face.
2. Secure the intermediate to the engine with nuts. Be careful not to damage the stationary ring on the engine shaft threads.
3. Slide the rotating portion of the seal onto the sleeve until the face is just flush with the sleeve end. Slide the sleeve onto the shaft until the seal faces contact. Continue to push the sleeve through the seal until the sleeve end seats against the shaft collar (B17) on the engine shaft.
4. Install the seal spring. Make sure that all components of the seal are seated squarely.

Install Impeller:

Install impeller shims previously removed, if so equipped. Inspect impeller and replace if cracked or badly worn.

1. Position impeller on end of engine threaded shaft. Impeller threads on clockwise. Thread impeller onto shaft until it seats squarely against shaft sleeve or shims. Make certain that the seal spring is centered on the impeller hub.

For pumps equipped with a balancing ring [25FP23AR], check for free rotation of impeller. Make sure there is no binding against balancing ring. A slight rub is acceptable.

Install Discharge Check Valve Body:

1. Install check valve arm into the check valve body, arm pivot ears fit into cast pockets in body. Arm must pivot with no binding.
2. Slide flange gasket on check valve body studs.
3. Position check valve body assembly on casing discharge flange, slide studs into flange holes. Body discharge must point horizontally to the right when looking at casing suction inlet.
4. Fasten with four nuts.

Reach in discharge and make certain check valve arm operates properly.

Install Casing:

If the wear ring or inlet tube was removed from the casing, apply Loctite® or similar thread locker to casing bore. Position a new ring or tube on casing bore. Press ring or tube into bore until it seats squarely against bore bottom shoulder.

1. Install casing o-ring on intermediate.
2. Install casing on intermediate.
3. Fasten with nuts and lock washers.

NOTE: Check that impeller rotates freely with no binding, a slight rub is acceptable, but engine shaft must rotate freely.

4. Install primer vacuum hose female SAE swivel fitting to male SAE flare fitting attached to fittings in casing suction nose.

Exhaust Primer Reassembly and Installation:

1. Install valve body on muffler outlet [25FP23AR] or slide nipple [25FP13AR] onto muffler outlet, fix in position with muffler clamp.
2. Install venturi into valve body.
3. Install ejector body onto venturi.
4. Install ejector jet into ejector body.
5. Install vacuum hose NPT fitting into valve body.

NOTE: All parts thread on clockwise. Use a high temperature thread sealant. Do not get sealant on venturi or ejector jet high velocity center port.

6. Install SAE female fitting of vacuum hose onto male SAE fitting, that is part of casing vacuum fitting assembly.

25FP Fire Pump Series

Hand Primer Reassembly and Installation:

1. Install new diaphragm if needed on plunger rod, secure with fastener.
2. Position diaphragm in body groove.
3. Install lower body half to upper half with screws.

NOTE: Inspect inlet check ball for wear and correct operation, replace as needed.

4. Install new inlet check ball, check ball seat bushing and reducing bushing into lower body half.
5. Install street elbow and vacuum hose assembly.
6. Install hand primer assembly onto frame mounting bracket with screws.
7. Install SAE female fitting of vacuum hose onto male SAE fitting, that is part of casing vacuum fitting assembly.

EVAPORATIVE EMISSIONS CONTROL INFORMATION

(Pertains to gasoline fuel only)

Maintenance

1. Periodically check fuel lines, vent lines, fittings, fuel tank and tank cap for damage or leaks. Clean as needed. Replace any leaking or damaged parts with direct factory replacements or identical EPA certified equivalents.
2. Replacement fuel lines must have the same SAE rating. Fittings must be same type and material. Use factory replacement fuel tank. Tank cap must be metal non-venting type.

Warranty

These warranty statements apply solely to the evaporative emissions equipment installed on the unit; fuel tank, fuel tank cap, fuel line, tank vent line, fittings and valves. For warranty information pertaining to all other parts, see the general AMT warranty at <http://www.amtpump.com/products/PDF/warranty.pdf> or contact AMT directly for a printed copy.

1. The evaporative emissions equipment on gasoline fueled pumps is designed, built and equipped to conform to current EPA requirements. They are warranted to be free from defects in materials and workmanship.
2. Warranty coverage may be denied if a part has failed due to abuse, neglect, improper maintenance or unapproved modifications.
3. Warranty period is two years from point of first retail sale.
4. Any warranty claim concerning the evaporative emissions equipment must be directed to the person who last sold the pump, a local distributor, or directly to AMT Pump Company (AMT).
5. Any part deemed to be defective by AMT will be replaced at no charge and shipped directly to the end user or distributor for replacement. AMT may require the end user to first return the part in question for inspection before replacement parts are shipped.

25FP Fire Pump Series

For Repair Parts contact dealer where pump was purchased.

Please provide following information:

-Model Number

-Serial Number (if any)

Part description and number as shown in parts list

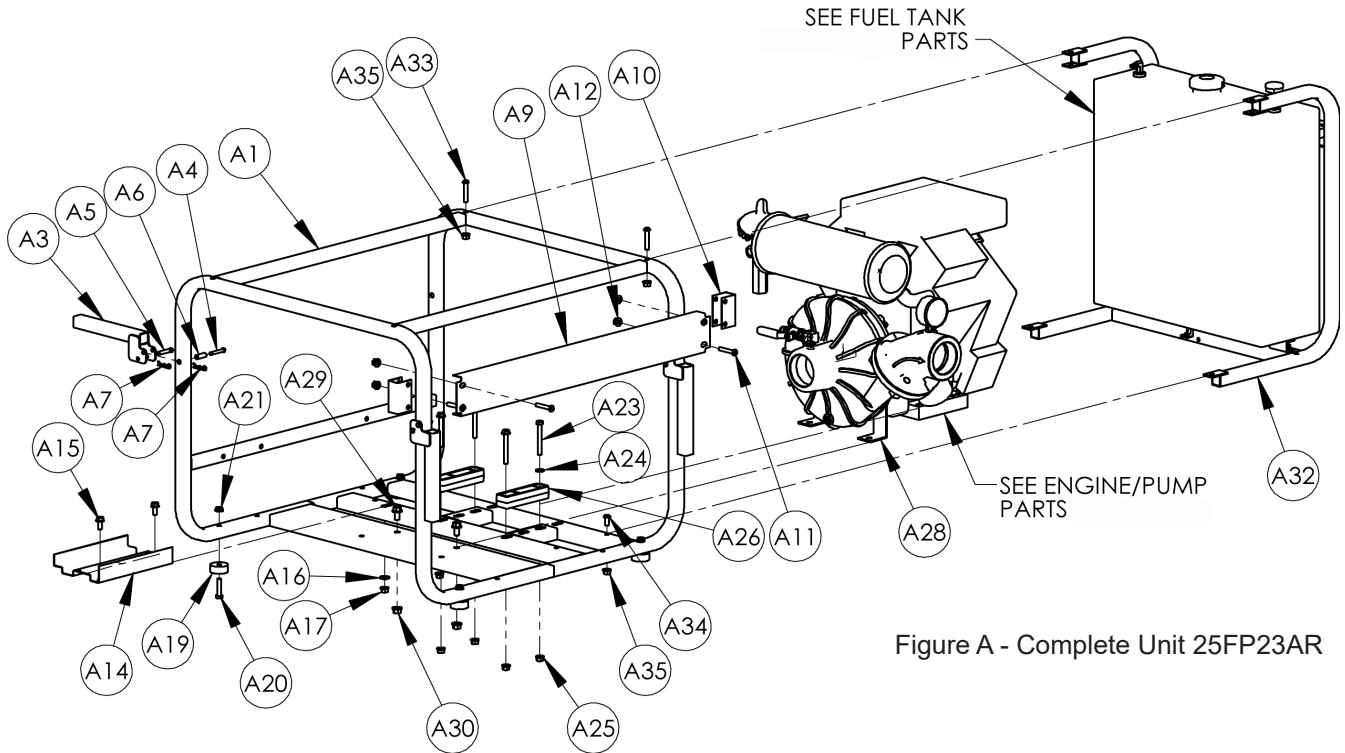

Figure A - Complete Unit 25FP23AR

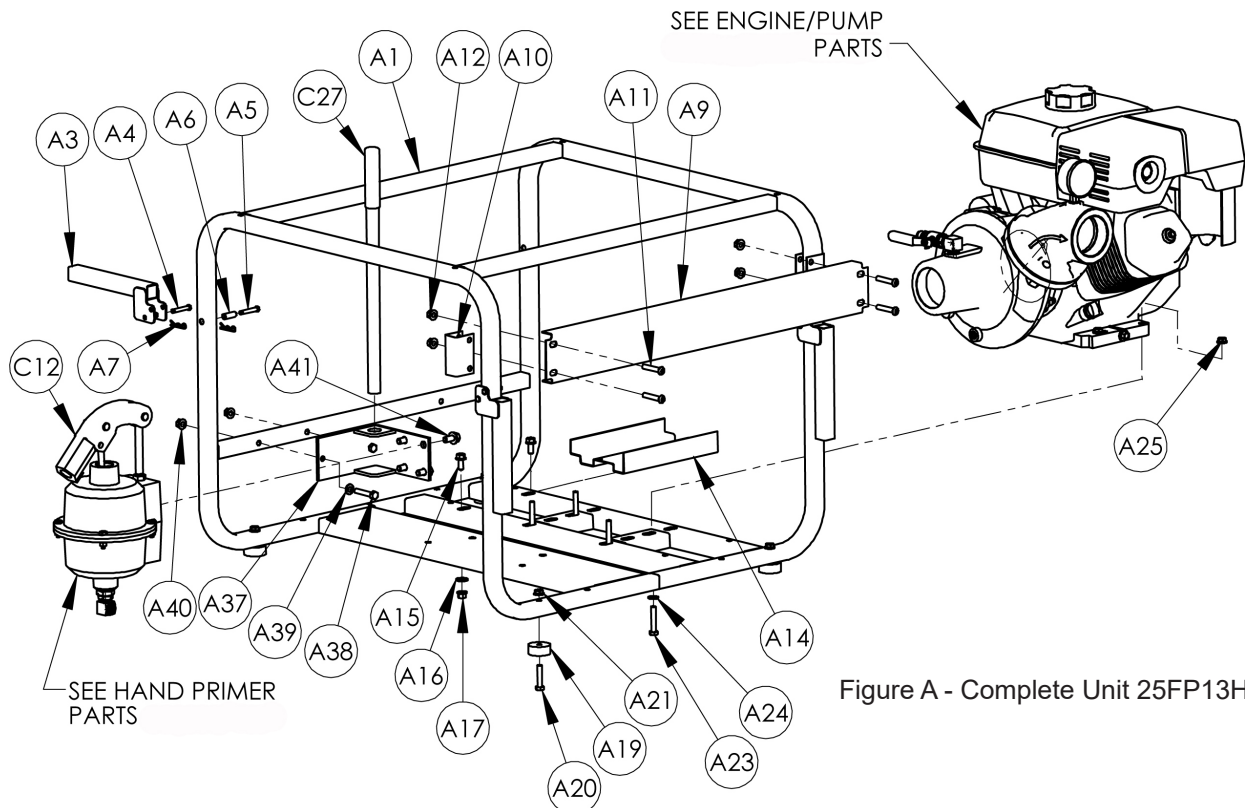

Figure A - Complete Unit 25FP13HR ONLY

Repair Parts List - Complete Unit (Reference Figure A)

Ref No.	Description	Part Number of Model					Qty
		25FP23AR	25FP13AR	25FP13HR	25FP13ZR	25FP10YR	
A1	Roll Frame	C404-100-00	C404-100-00	C404-100-00	C404-100-00	C404-100-00	1
A2	Handle Kit	C404-120-90	C404-120-90	C404-120-90	C404-120-90	C404-120-90	1
	(includes Ref. Nos. A3 to A7)						
A3	Handle	Incl. w/A2	Incl. w/A2	Incl. w/A2	Incl. w/A2	Incl. w/A2	4
A4	Lock Pin	Incl. w/A2	Incl. w/A2	Incl. w/A2	Incl. w/A2	Incl. w/A2	2
A5	Pivot Pin	Incl. w/A2	Incl. w/A2	Incl. w/A2	Incl. w/A2	Incl. w/A2	2
A6	Pivot Bearing	Incl. w/A2	Incl. w/A2	Incl. w/A2	Incl. w/A2	Incl. w/A2	4
A7	Hairpin Cotter	Incl. w/A2	Incl. w/A2	Incl. w/A2	Incl. w/A2	Incl. w/A2	8
A8	Panel Kit	C404-102-90	C404-102-90	C404-102-90	C404-102-90	C404-102-90	1
	(includes Ref. Nos. A9 to A12)						
A9	Panel	Incl. w/A8	Incl. w/A8	Incl. w/A8	Incl. w/A8	Incl. w/A8	1
A10	Panel Mounting Bracket	Incl. w/A8	Incl. w/A8	Incl. w/A8	Incl. w/A8	Incl. w/A8	2
A11	Bolt 5/16-18 x 1-1/2"	Incl. w/A8	Incl. w/A8	Incl. w/A8	Incl. w/A8	Incl. w/A8	4
A12	Nut 5/16-18	Incl. w/A8	Incl. w/A8	Incl. w/A8	Incl. w/A8	Incl. w/A8	4
A13	Battery Tray Kit	C404-107-90	C404-107-90	C404-107-90	C404-107-90	C404-107-90	1
	(includes Ref. Nos. A14 to A17)						
A14	Battery Tray & Battery Hold Down	Incl. w/A13	Incl. w/A13	Incl. w/A13	Incl. w/A13	Incl. w/A13	1
A15	Bolt 5/16-18 x 3/4"	Incl. w/A13	Incl. w/A13	Incl. w/A13	Incl. w/A13	Incl. w/A13	2
A16	Flat Washer	Incl. w/A13	Incl. w/A13	Incl. w/A13	Incl. w/A13	Incl. w/A13	2
A17	Nut 5/16-18	Incl. w/A13	Incl. w/A13	Incl. w/A13	Incl. w/A13	Incl. w/A13	2
A18	Rubber Foot Kit	C400-100-91	C400-100-91	C400-100-91	C400-100-91	C400-100-91	1
	(includes Ref. Nos. A19 to A21)						
A19	Rubber Foot	Incl. w/A18	Incl. w/A18	Incl. w/A18	Incl. w/A18	Incl. w/A18	4
A20	Bolt 5/16-18 x 1-1/2"	Incl. w/A18	Incl. w/A18	Incl. w/A18	Incl. w/A18	Incl. w/A18	4
A21	Nut 5/16-18	Incl. w/A18	Incl. w/A18	Incl. w/A18	Incl. w/A18	Incl. w/A18	4
A22	Engine Mounting Hardware Kit	25FP-420-90	25FP-420-90	25FP-420-90	25FP-421-90	25FP-421-90	1
	(includes Ref. Nos. A23 to A25)						
A23	Mounting Bolt	Incl. w/A22	Incl. w/A22	Incl. w/A22	Incl. w/A22	Incl. w/A22	4
A24	Flat Washer	Incl. w/A22	Incl. w/A22	Incl. w/A22	Incl. w/A22	Incl. w/A22	4
A25	Hex Nut	Incl. w/A22	Incl. w/A22	Incl. w/A22	Incl. w/A22	Incl. w/A22	4
A26	Raising Block	N/A	N/A	N/A	N/A	N/A	2
A27	Casing Foot Kit	Discontinued	N/A	N/A	N/A	N/A	1
	(includes Ref. Nos. A28 to A30)						
A28	Casing Foot	Incl. w/A27	N/A	N/A	N/A	N/A	2
A29	Bolt 5/16-18 x 3/4"	Incl. w/A27	N/A	N/A	N/A	N/A	2
A30	Nut 5/16-18	Incl. w/A27	N/A	N/A	N/A	N/A	2
A31	Tank Frame Kit	Discontinued	N/A	N/A	N/A	N/A	1
	(includes Ref. Nos. A32 to A35)						
	(NOTE: Does not include fuel tank, fittings, or tank mounting hardware)						
A32	Tank Frame	Incl. w/A31	N/A	N/A	N/A	N/A	1
A33	Bolt 5/16-18 x 1-3/4"	Incl. w/A31	N/A	N/A	N/A	N/A	2
A34	Bolt 5/16-18 x 3/4"	Incl. w/A31	N/A	N/A	N/A	N/A	2
A35	Nut 5/16-18	Incl. w/A31	N/A	N/A	N/A	N/A	4
A36	Hand Primer Bracket Kit	N/A	N/A	C405-170-90	C405-170-90	C405-170-90	1
	(includes Ref. Nos. A37 to A41)						
A37	Mounting Bracket	N/A	N/A	Incl. w/A36	Incl. w/A36	Incl. w/A36	1
A38	Bolt 5/16-18 x 1-3/4"	N/A	N/A	Incl. w/A36	Incl. w/A36	Incl. w/A36	2
A39	Flat Washer	N/A	N/A	Incl. w/A36	Incl. w/A36	Incl. w/A36	2
A40	Nut 5/16-18	N/A	N/A	Incl. w/A36	Incl. w/A36	Incl. w/A36	2
A41	Screw 3/8-16 x 3/4"	N/A	N/A	Incl. w/A36	Incl. w/A36	Incl. w/A36	4
A42	Battery Cable (-) (not shown)	3102-104-90	3102-104-90	3102-104-90	3102-104-90	3102-104-90	1
A43	Battery Cable (+) (not shown)	3102-105-90	3102-105-90	3102-105-90	3102-105-90	3102-105-90	1

25FP Fire Pump Series

For Repair Parts contact dealer where pump was purchased.

Please provide following information:

-Model Number

-Serial Number (if any)

Part description and number as shown in parts list

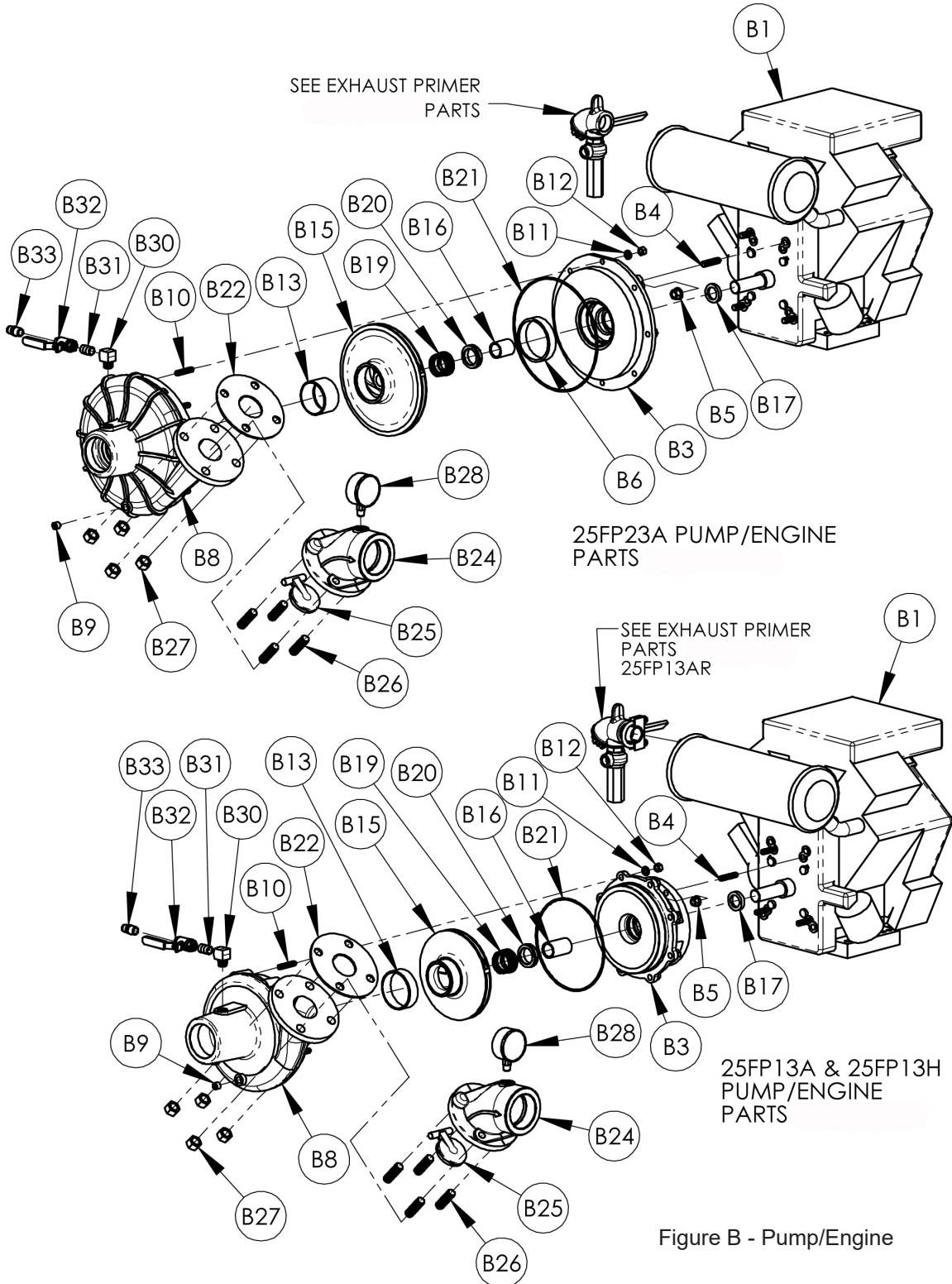

Figure B - Pump/Engine

Repair Parts List - Pump/Engine (Reference Figure B)

Ref No.	Description	Part Number of Model					Qty
		25FP23AR	25FP13AR	25FP13HR	25FP13ZR	25FP10YR	
B1	23HP Vanguard Engine	Discontinued	N/A	N/A	N/A	N/A	1
	13HP Vanguard Engine	N/A	Discontinued	N/A	N/A	N/A	1
	GX390 Honda Engine	N/A	N/A	1639-031-00	N/A	N/A	1
	1B50 Hatz Diesel	N/A	N/A	N/A	1630-050-00	N/A	1
	L100 Yanmar Diesel	N/A	N/A	N/A	N/A	Discontinued	1
B2	Intermediate/Adapter Kit (includes Ref. Nos. B3 to B6 – 25FP23AR) (includes Ref. Nos. B3 to B5 – 25FP13AR & 25FP23AR)	25FP-031-96	25FP-030-96	25FP-030-96	25FP-033-96	25FP-032-96	1
B3	Intermediate/Adapter	Incl. w/B2	Incl. w/B2	Incl. w/B2	Incl. w/B2	Incl. w/B2	1
B4	Stud (NO LONGER USED)	Incl. w/B2	Incl. w/B2	Incl. w/B2	Incl. w/B2	Incl. w/B2	4
B5	Nut	Incl. w/B2	Incl. w/B2	Incl. w/B2	Incl. w/B2	Incl. w/B2	4
B6	Balancing Ring	Incl. w/B2	N/A	N/A	N/A	N/A	1
B7	Casing Kit (includes Ref. Nos. B8 to B13)	25FP-002-96	25FP-001-96	25FP-001-96	25FP-001-96	25FP-001-96	1
B8	Casing	Incl. w/B7	Incl. w/B7	Incl. w/B7	Incl. w/B7	Incl. w/B7	1
B9	Drain Plug	Incl. w/B7	Incl. w/B7	Incl. w/B7	Incl. w/B7	Incl. w/B7	1
B10	Stud 3/8-16 x 1-3/4"	Incl. w/B7	Incl. w/B7	Incl. w/B7	Incl. w/B7	Incl. w/B7	8
B11	Lock Washer 3/8"	Incl. w/B7	Incl. w/B7	Incl. w/B7	Incl. w/B7	Incl. w/B7	8
B12	Nut 3/8-16	Incl. w/B7	Incl. w/B7	Incl. w/B7	Incl. w/B7	Incl. w/B7	8
B13	Wear Ring/Inlet	Incl. w/B7	Incl. w/B7	Incl. w/B7	Incl. w/B7	Incl. w/B7	1
B14	Impeller Kit (includes Ref. Nos. B15 to B17)	25FP-010-96	25FP-011-96	25FP-011-96	25FP-011-96	25FP-011-96	1
B15	Impeller	Incl. w/B14	Incl. w/B14	Incl. w/B14	Incl. w/B14	Incl. w/B14	1
B16	Shaft Sleeve & Shaft Collar Kit (includes Ref. Nos. B16 to B17)	25FP-142-90 & Incl. w/B14	25FP-142-90 & Incl. w/B14	25FP-142-90 & Incl. w/B14	25FP-142-90 & Incl. w/B14	25FP-142-90 & Incl. w/B14	1
B17	Shaft Collar	Incl. w/B14	Incl. w/B14	Incl. w/B14	Incl. w/B14	Incl. w/B14	1
B18	Seal Kit (includes Ref. Nos. B18 & B19)	1646-324-00	1646-324-00	1646-324-00	1646-324-00	1646-324-00	1
B18-2	Gasket Kit (includes Ref. Nos. B18 to B22)	25FP-301-90	25FP-301-90	25FP-301-90	25FP-301-90	25FP-301-90	1
B19	Seal Head (Rotating Head)	Incl. w/B18	Incl. w/B18	Incl. w/B18	Incl. w/B18	Incl. w/B18	1
B20	Seal Seat (Stationary Ring)	Incl. w/B18	Incl. w/B18	Incl. w/B18	Incl. w/B18	Incl. w/B18	1
B21	O-Ring (#270 – 25FP23, #263 – 25FP13)	Incl. w/B18	Incl. w/B18	Incl. w/B18	Incl. w/B18	Incl. w/B18	1
B22	Flange Gasket	Incl. w/B18	Incl. w/B18	Incl. w/B18	Incl. w/B18	Incl. w/B18	1
B23	Discharge Check Valve Body Kit (includes Ref. Nos. B24 to B28)	25FP-070-96	25FP-070-96	25FP-070-96	25FP-070-96	25FP-070-96	1
B24	Check Valve Body	Incl. w/B23	Incl. w/B23	Incl. w/B23	Incl. w/B23	Incl. w/B23	1
B25	Check Valve Arm	Incl. w/B23	Incl. w/B23	Incl. w/B23	Incl. w/B23	Incl. w/B23	1
B26	Stud 5/8-11 x 2"	Incl. w/B23	Incl. w/B23	Incl. w/B23	Incl. w/B23	Incl. w/B23	4
B27	Nut 5/8-11	Incl. w/B23	Incl. w/B23	Incl. w/B23	Incl. w/B23	Incl. w/B23	4
B28	Pressure Gauge	Incl. w/B23	Incl. w/B23	Incl. w/B23	Incl. w/B23	Incl. w/B23	1
B29	Casing Vacuum Fitting Kit (includes Ref. Nos. B30 to B33)	25FP-171-90	25FP-171-90	25FP-171-90	25FP-171-90	25FP-171-90	1
B30	Street Elbow 3/8" NPT	Incl. w/B29	Incl. w/B29	Incl. w/B29	Incl. w/B29	Incl. w/B29	1
B31	Pipe Nipple 3/8" NPT	Incl. w/B29	Incl. w/B29	Incl. w/B29	Incl. w/B29	Incl. w/B29	1
B32	Ball Valve 3/8" NPT	Incl. w/B29	Incl. w/B29	Incl. w/B29	Incl. w/B29	Incl. w/B29	1
B33	NPT x SAE Flare Fitting 3/8"	Incl. w/B29	Incl. w/B29	Incl. w/B29	Incl. w/B29	Incl. w/B29	1
B34	Wear Ring Kit (includes Ref. Nos. B6 & B13 – 25FP23) (includes Ref. No. B13 – 25FP13)	25FP-060-90	25FP-061-90	25FP-061-90	25FP-061-90	25FP-061-90	1
N/S	Muffler Kit (not shown)	Contact Briggs & Stratton	N/A	N/A	N/A	N/A	1

25FP Fire Pump Series

For Repair Parts contact dealer where pump was purchased.

Please provide following information:

-Model Number

-Serial Number (if any)

Part description and number as shown in parts list

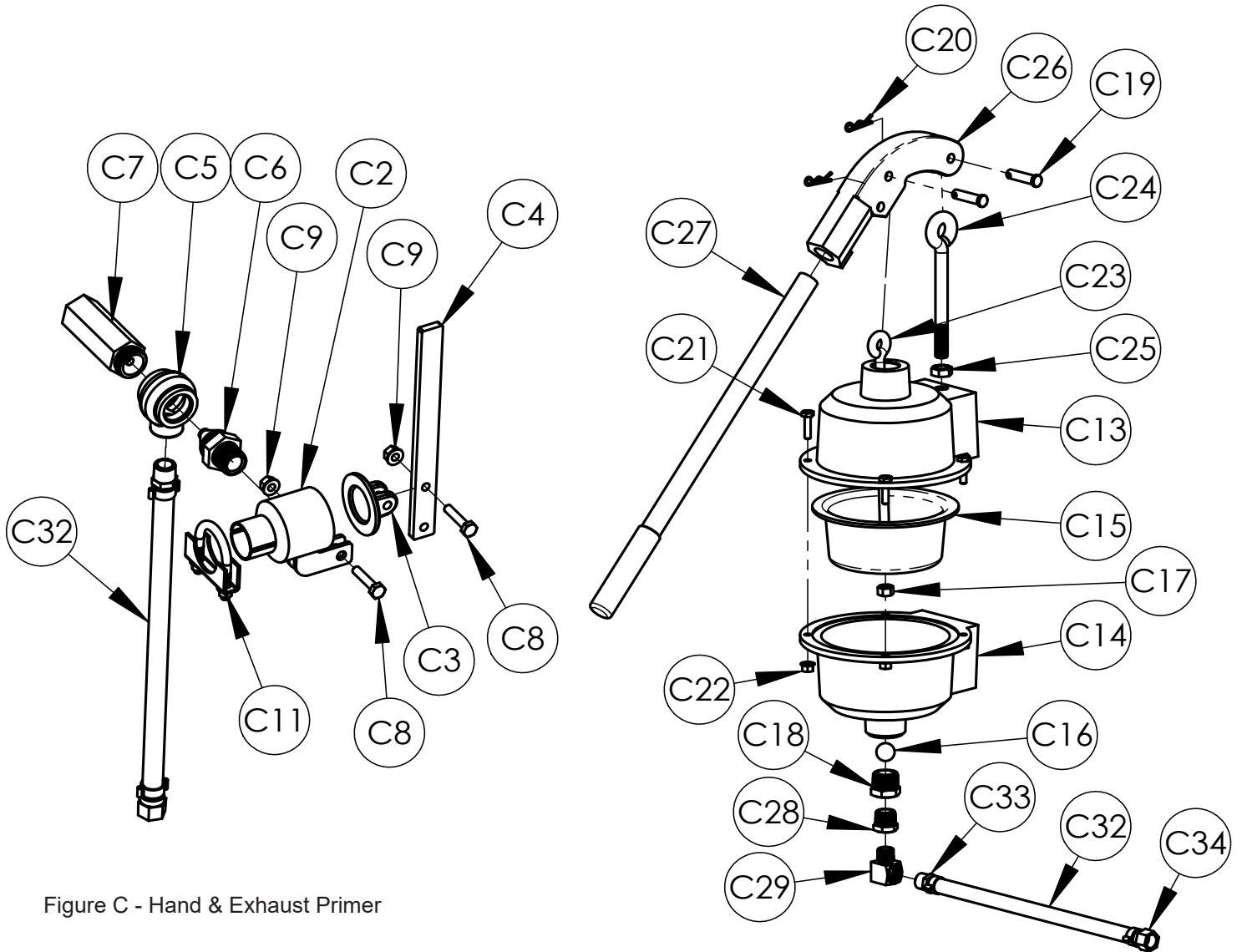

Figure C - Hand & Exhaust Primer

Repair Parts List – Hand & Exhaust Primer (Reference Figure C)

Ref No.	Description	Part Number of Model					Qty
		25FP23AR	25FP13AR	25FP13HR	25FP13ZR	25FP10YR	
C1	Exhaust Primer Assembly (includes Ref. Nos. C2 to C11)	Discontinued	Discontinued	N/A	N/A	N/A	1
C2	Valve Body	Incl. w/C1	Incl. w/C1	N/A	N/A	N/A	1
C3	Valve Cap	Incl. w/C1	Incl. w/C1	N/A	N/A	N/A	1
C4	Handle	Incl. w/C1	Incl. w/C1	N/A	N/A	N/A	1
C5	Ejector Body	Incl. w/C1	Incl. w/C1	N/A	N/A	N/A	1
C6	Venturi	Incl. w/C1	Incl. w/C1	N/A	N/A	N/A	1
C7	Ejector Jet	Incl. w/C1	Incl. w/C1	N/A	N/A	N/A	1
C8	Bolt ¼-20 x 1-1/4"	Incl. w/C1	Incl. w/C1	N/A	N/A	N/A	2
C9	Nut ¼-20	Incl. w/C1	Incl. w/C1	N/A	N/A	N/A	2
C10	Connecting Nipple	Discontinued	Discontinued	N/A	N/A	N/A	1
C11	Clamp	Incl. w/C1	Incl. w/C1	N/A	N/A	N/A	1
C12	Hand Primer Assembly (includes Ref. Nos. C13 to C27)	N/A	N/A	C405-170-90	C405-170-90	C405-170-90	1
C13	Pump Body Upper Half	N/A	N/A	Incl. w/C12	Incl. w/C12	Incl. w/C12	1
C14	Pump Body Lower Half	N/A	N/A	Incl. w/C12	Incl. w/C12	Incl. w/C12	1
C15	Diaphragm	N/A	N/A	Incl. w/C12	Incl. w/C12	Incl. w/C12	1
C16	Check Ball	N/A	N/A	Incl. w/C12	Incl. w/C12	Incl. w/C12	1
C17	Nut	N/A	N/A	Incl. w/C12	Incl. w/C12	Incl. w/C12	1
C18	Check Ball Seating Bushing	N/A	N/A	Incl. w/C12	Incl. w/C12	Incl. w/C12	1
C19	Pin	N/A	N/A	Incl. w/C12	Incl. w/C12	Incl. w/C12	1
C20	Cotter	N/A	N/A	Incl. w/C12	Incl. w/C12	Incl. w/C12	1
C21	Bolt	N/A	N/A	Incl. w/C12	Incl. w/C12	Incl. w/C12	1
C22	Nut	N/A	N/A	Incl. w/C12	Incl. w/C12	Incl. w/C12	1
C23	Plunger Rod	N/A	N/A	Incl. w/C12	Incl. w/C12	Incl. w/C12	1
C24	Pivot Rod	N/A	N/A	Incl. w/C12	Incl. w/C12	Incl. w/C12	1
C25	Nut	N/A	N/A	Incl. w/C12	Incl. w/C12	Incl. w/C12	1
C26	Handle Casting	N/A	N/A	Incl. w/C12	Incl. w/C12	Incl. w/C12	1
C27	Handle	N/A	N/A	Incl. w/C12	Incl. w/C12	Incl. w/C12	1
C28	Reducing Bushing	N/A	N/A	5160-171-00	5160-171-00	5160-171-00	1
C29	Street Elbow 3/8" NPT	N/A	N/A	1768-024-00	1768-024-00	1768-024-00	1
C30	Diaphragm Repair Kit (includes Ref. Nos. C15 & C16)	N/A	N/A	C405-300-90	C405-300-90	C405-300-90	1
C31	Vacuum Hose Assembly (includes Ref. Nos. C32 to C34)	25FP-170-90	25FP-170-90	25FP-170-90	25FP-170-90	25FP-170-90	1
C32	Hose	Incl. w/C31	Incl. w/C31	Incl. w/C31	Incl. w/C31	Incl. w/C31	1
C33	Male NPT 3/8" x Hose Fitting	Incl. w/C31	Incl. w/C31	Incl. w/C31	Incl. w/C31	Incl. w/C31	1
C34	Female SAE Flare x Hose Fitting	Incl. w/C31	Incl. w/C31	Incl. w/C31	Incl. w/C31	Incl. w/C31	1

25FP Fire Pump Series

For Repair Parts contact dealer where pump was purchased.

Please provide following information:

-Model Number

-Serial Number (if any)

Part description and number as shown in parts list

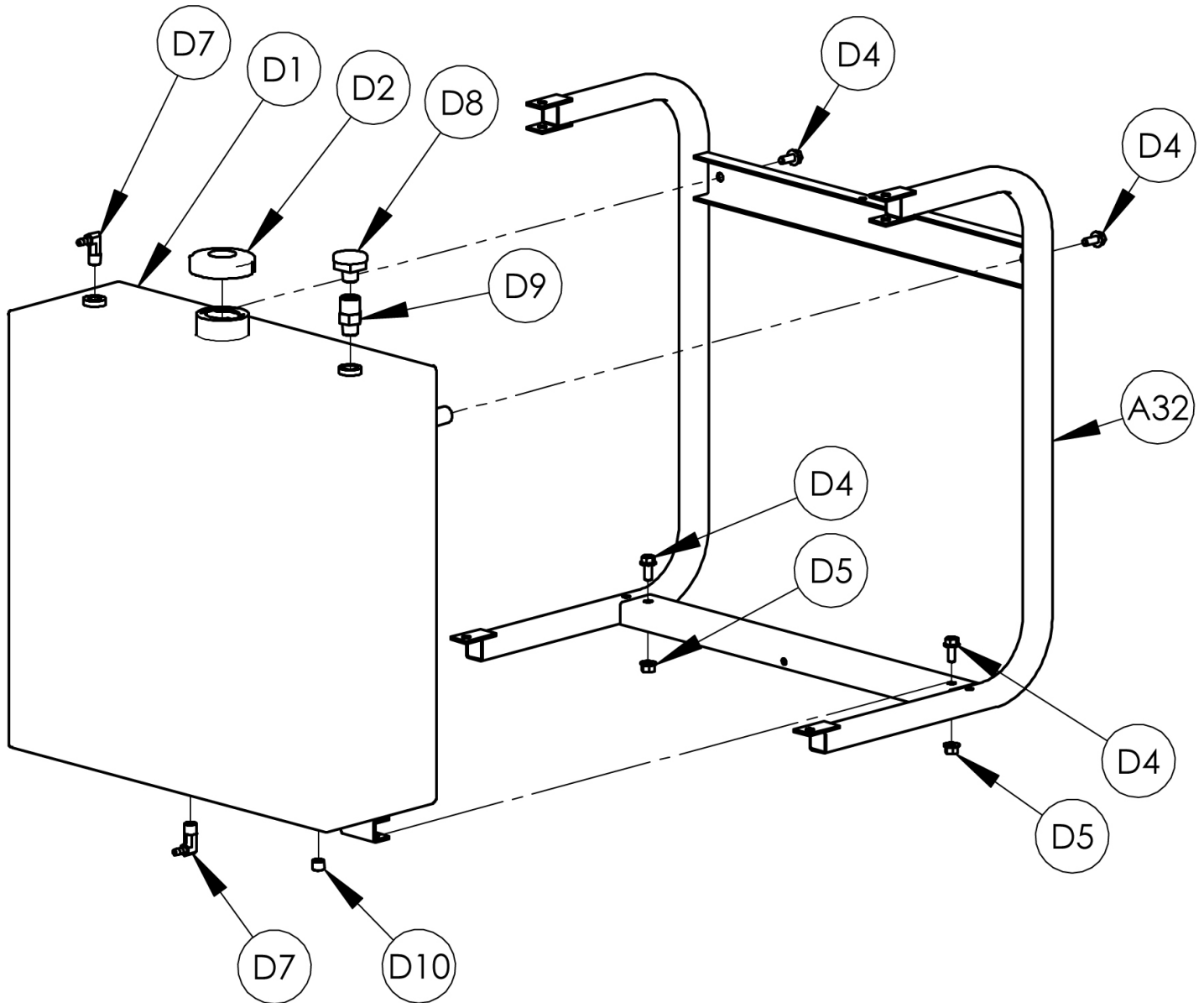

Figure D - Fuel Tank

Repair Parts List – Fuel Tank (Reference Figure D)

Ref No.	Description	Part Number of Model					Qty
		25FP23AR	25FP13AR	25FP13HR	25FP13ZR	25FP10YR	
D1	Fuel Tank	Discontinued	N/A	N/A	N/A	N/A	1
D2	Fuel Cap Kit	Discontinued	N/A	N/A	N/A	N/A	1
D3	Tank Mount Hardware Kit (includes Ref. Nos. D4 & D5)	C404-171-90	N/A	N/A	N/A	N/A	1
D4	Bolt 5/16-18 x 3/4"	Incl. w/D3	N/A	N/A	N/A	N/A	4
D5	Nut 5/16-18	Incl. w/D3	N/A	N/A	N/A	N/A	2
D6	Fuel Tank Fitting Kit (includes Ref. Nos. D7 to D14)	C404-170-90	N/A	N/A	N/A	N/A	1
D7	Elbow 1/4" NPT x 1/4" Hose Barb	Incl. w/D6	N/A	N/A	N/A	N/A	2
D8	Vent 3/8" NPT	Incl. w/D6	N/A	N/A	N/A	N/A	1
D9	Check Valve	Incl. w/D6	N/A	N/A	N/A	N/A	1
D10	Plug 1/4" NPT	Incl. w/D6	N/A	N/A	N/A	N/A	1
D11	Hose Connector 1/4" x 3/16" (not shown)	Incl. w/D6	N/A	N/A	N/A	N/A	1
D12	Fuel Hose 1/4" x 12" (not shown)	Incl. w/D6	N/A	N/A	N/A	N/A	1
D13	Fuel Hose 1/4" x 18" (not shown)	Incl. w/D6	N/A	N/A	N/A	N/A	1
D14	Hose Clamp (not shown)	Incl. w/D6	N/A	N/A	N/A	N/A	5



AMT Pump Company
(herein "AMT")
400 Spring Street
Royersford, PA 19468
Phone: (610) 948-3800
Fax: (610) 948-5300
www.amtpump.com



General Information

SALES POLICY: AMT products are sold through our established Distributors. We do not sell direct to the consumer or organization not entitled to trade recognition. Therefore, possession of our catalogs and/or price list(s) does not infer an offer to sell.

MINIMUM ORDER: We appreciate your order, however, all orders are subject to a minimum \$35.00 net invoice charge (excluding freight). This applies to all pump and parts purchase orders.

PRICES: Prices are subject to change without notice. All orders accepted are subject to prices in effect at time of shipment.

PAYMENT TERMS: Terms, upon establishment of credit, are Net 30 days. Past due accounts may be subject to a service charge of 1.5% per month. Domestic or assignable letter of credit is required for all export trade.

PAST DUE ACCOUNTS: AMT reserves the right to withhold open account shipments on any past due account. Invoices are considered past due after thirty (30) days. In the interest of sound business, all orders are subject to approval of the Credit Department.

SHIPPING INSTRUCTIONS: All shipments will be made F.O.B. the factory. Where instructions for shipment do not appear on the order, the shipment will be made according to our best judgment. Full risk of loss (including transportation delays and losses) shall pass to the customer upon delivery of the products to the carrier at the F.O.B. point. When loss or delay occurs, primary responsibility for tracing rests with the customer. When there is LOSS or APPARENT VISIBLE DAMAGE to a shipment, when tendered for delivery, *DO NOT* give the carrier a clear receipt. Note such damage on the carrier's delivery receipt and *HAVE THE DRIVER SIGN THE RECEIPT.*

PRODUCT REVISIONS: AMT reserves the right to discontinue, change or improve its products or any portions thereof without being obligated to provide such a change or improvement for units sold and/or shipped prior to such a change or improvement.

LEAD TIME: Products designated "Quick Ship Product", also referred to as "QSP" will normally be shipped within 24 hours of receipt of a non-cancellable purchase order. Only limited quantities of "QSP" pumps are available.

STANDARD LEAD TIME: Lead time is two weeks for all non "QSP" product. AMT reserves the right to revise lead times as required due to availability of materials and all other causes beyond our control.

VIP SHIPMENT: Select AMT and IPT branded pumps are available for next day shipment for non-QSP (Quick Ship Products) items and subjected to a specific model surcharge per unit noted in the respective price book. Requires calling for availability, confirmation and a non-cancellable purchase order or credit card payment prior to shipment. The expedited shipping charges are an additional cost added separately from the VIP charges per item. AMT reserves the right to revise lead times as required due to availability of materials and all other causes beyond our control. QSP quantities are limited as determined by AMT.

ALL purchase orders must be submitted via hard copy sent to AMT customer service department by fax, EDI or e-mail.

RETURN GOODS POLICY: Goods shall not be returned without a return goods authorization number (RGA) issued by AMT customer service. The RGA number must be listed on the packing list. Only current model and part numbers with a valid date code may be returned (within one year from date of purchase). **A 20% restocking and packaging charge will apply to all returns. All shipping charges must be pre-paid. No exceptions.**

ORDER CHANGES BY CUSTOMER: Orders in process may not be changed except with written consent and may be subject to special charges.

12 Month Limited Warranty

EXTENT AND DURATION OF LIMITED WARRANTY

Coverage: AMT Pump Company (herein "AMT") or IPT Pumps by Gorman-Rupp (herein "IPT") or Gorman-Rupp Industries Division of the The Gorman-Rupp Company, Patterson, or the Gorman-Rupp Company (herein referred to as "G-R Unit) each individually warrants that its products and parts shall be free from defects in material and workmanship for twelve (12) months from the date of purchase by the original end user when installation is made and maintenance is performed in accordance with G-R Unit's recommendations. Wear and tear resulting from use and items normally consumed in use are not covered.

EXCEPTIONS

(A) This Limited Warranty shall not apply to mechanical seals in AMT or IPT pumps and the following products and parts: engines, motors, trade accessories and all other products, components, parts and materials not manufactured by the G-R Units. These items may, however, be covered by the warranties of their respective manufacturers. (B) This warranty does not extend to or apply to any unit which has been repaired or altered at any place other than by a G-R Unit, or by persons not expressly approved by a G-R Unit to make repairs or alterations, nor to any unit the serial number, model number or identification of which has been removed, defaced or altered. (C) This warranty does not extend to any product manufactured by a G-R Unit, which has been subjected to mis-use, neglect, accident, improper installation, or use in violation of instructions furnished by a G-R Unit. (D) Pump Kits: This warranty does not extend to any product sold by a G-R Unit unassembled as a Pump Kit. Pump Kits are warranted against defects in material and workmanship for 60 days from the date of shipment from a G-R Unit. Any Pump Kit parts deemed defective by a G-R Unit will be replaced free of charge within 60 days of shipment. Pump Kits are not returnable for credit.

LIMITATIONS

THE G-R UNITS' SOLE AND EXCLUSIVE WARRANTY WITH RESPECT TO THEIR PRODUCTS AND PARTS IS THIS LIMITED WARRANTY. THIS LIMITED WARRANTY IS IN LIEU OF ALL OTHER EXPRESS AND/OR IMPLIED WARRANTIES, INCLUDING IMPLIED WARRANTIES OF MERCHANTABILITY AND FITNESS FOR PARTICULAR PURPOSE.

EXCLUSIVE REMEDY AND DAMAGES

The sole and exclusive remedy for breach of this Warranty by a G-R Unit and the entire extent of its liability for such breach or for damages arising from the use of the products and parts covered under this Limited Warranty, shall be as follows:

1. **Repair or Replacement:** If inspection shows that any G-R Unit product or part covered under this Limited Warranty is defective in materials or workmanship, the G-R Unit shall repair or replace the defective or non-conforming product or part without charge, whichever the G-R Unit chooses. You must have properly maintained and used the product or part claimed to be defective in accordance with the maintenance schedule or manual, which comes with the product. No allowance will be made for labor, installation, removal, transportation or other charges incurred by you in connection with such repair or replacement.
2. To obtain the above remedy:
 - A. Immediately notify the G-R Unit upon discovery of the claimed defect in materials or workmanship and provide the serial number or date code of the product and/or part(s) or provide the G-R Unit with the invoice or bill of sale referencing the product by no later than the expiration date of the warranty period.
 - B. The G-R Unit will advise whether inspection will be necessary and how whether repair or replacement will be made. If inspection by the G-R Unit is necessary, the pump or defective part must be sent freight pre-paid to the G-R Unit. Return shipment will be F.O.B. the G-R Unit's plant.
 - C. **Return Goods Authorization Requirement:** No product will be accepted for return or replacement without the prior written authorization of the G-R Unit. Upon such authorization, and in accordance with instructions from the G-R Unit, the product will be returned to the G-R Unit, shipping charges prepaid by the Buyer.
3. **Damages:** The G-R Unit's liability for damages for breach of this Limited Warranty shall not exceed the amount of the purchase price of the product or part(s) in respect to which Such damages are claimed. **IN NO EVENT SHALL THE G-R UNITS BE LIABLE FOR INCIDENTAL, CONSEQUENTIAL OR SPECIAL DAMAGES FOR BREACH OF THIS LIMITED WARRANTY.**

Some states do not allow the exclusion or limitation of incidental or consequential damages, so the above limitation or exclusion may not apply to you. This Limited Warranty gives you specific legal rights, and you may also have other rights, which vary from state to state.



A Gorman-Rupp Company

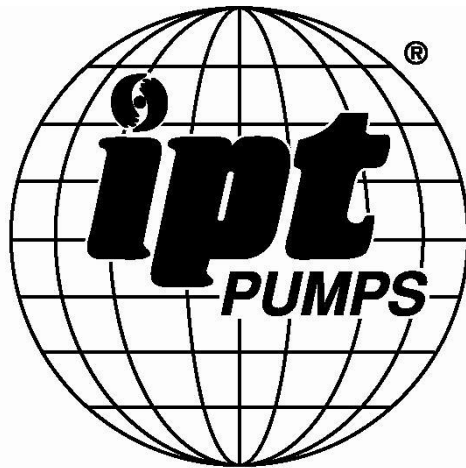

BY
GORMAN-RUPP®

www.amtpump.com