

ARO[®]

AFX Piston Pumps and Packages

simplicity
safety
reliability



Paired to perform

The right package for your application

Most applications require more than just a pump. ARO piston pumps offer a wide range of transfer, extrusion, and finishing packages that not only enhance your productivity, but also simplify the ordering process. We provide you with the right configuration of air motor, piston pump, mount, follower, controls, and down-stream accessories; you simply attach an air hose, connect the package to the fluid source, attach a fluid outlet line and you're good to go.

1 Pump

Coupled with our air motor, we can configure our 2-ball, 4-ball, and chop-check pumps to be optimised for your application.

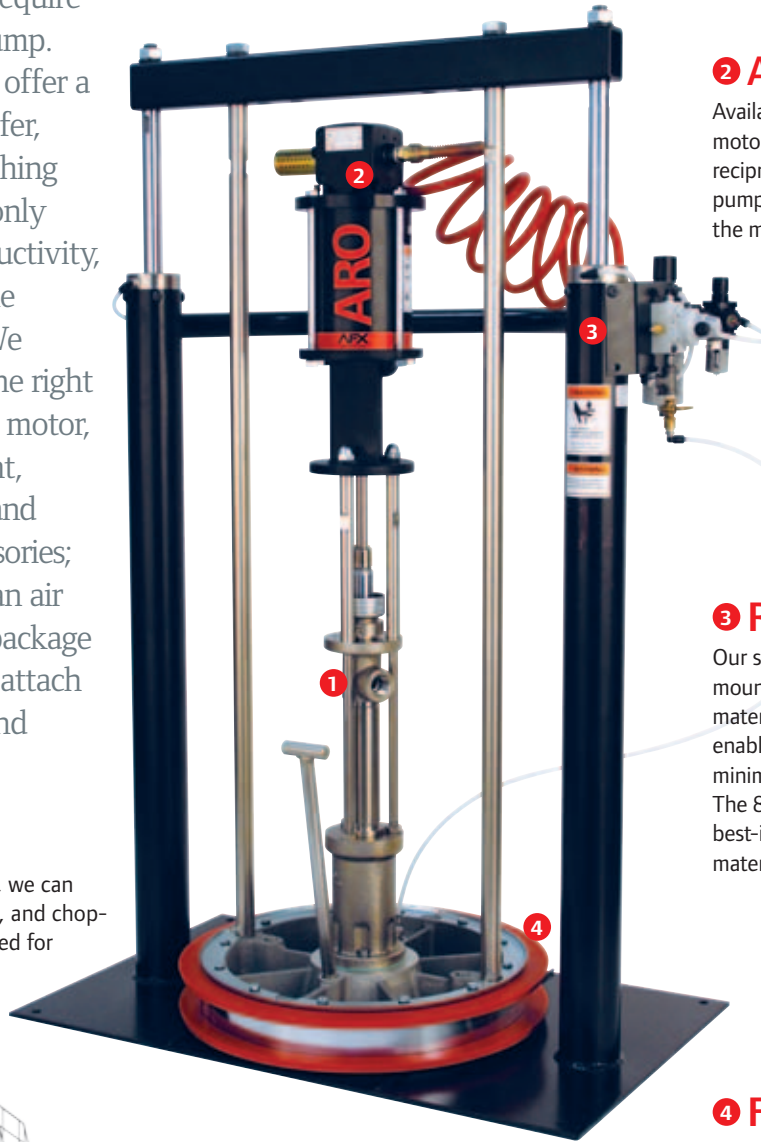

2 Air motor

Available in five sizes, our air motors provide power and reciprocating motion to our pumps. The larger the air motor, the more power it delivers.

3 Ram

Our single-post, two-post, and cart-mounted systems are used to pump material out of containers. They enable quick container changeover, minimising process interruptions. The 8.26 cm cylinders deliver best-in-class down force, improving material supply to the pump.

4 Follower plate

Connected to the pump and the ram, follower plates feed material into the pump from a variety of container sizes. In addition to improving pump performance, follower plates protect your material and reduce waste.



SIMPLY VERSATILE

LUBRICANTS • URETHANES • MASTICS • SILICONES

SEALANTS • ADHESIVES • CAULKS • INKS • EPOXIES

Application packages

FINISHING, COATINGS, SEALANTS, INKS, AND ADHESIVES



TPX Package

Features a two-post ram, pump, follower plate and controls designed for high-viscosity applications when maximum down force is required. Available in 20- and 220-gal containers.



SPX Package

Ideal for medium- to heavy-viscosity extrusion, ARO Fluid Product's single-post ram with pump, follower plate, and controls allows for easy container changeover while providing industry-leading down force during operation.



CMX Package

Popular in airless spray applications, these packages feature a high-pressure pump, air control, material filter, and suction hose — all mounted on a heavy-duty cart.



CLX Package

When portability is required for light- to medium-viscosity (less than 50,000 cPs) extrusion, our cart-mounted lift with follower plate allows for easy container changeover.



ALX Package

Ideal for finishing and adhesive applications where you need to keep fluid mixed. Includes lift, drum cover, agitator, and air controls.

LUBRICATION



DCX Package

The ARO line of lubrication pumps can be configured with a drum cover and air controls for the transfer and supply of oil and grease.



DMX Package

Same as DCX but this has a bung adapter to thread into container rather than a drum cover.

BULK MATERIAL TRANSFER / CIRCULATION



FMX Package

Ideal for fluid transfer from tanks and piping systems, pumps come with a floor-mountable stand to connect to inlet piping.



WMX Package

The compact design of our piston pumps make them ideal for mounting on walls or appropriate structures. This package includes the pump and bracket for vertical mounting on structures.

HIGH-PRESSURE CLEANING



WPX

When it is time to clean up, our wash pump is a great high-power cleaning solution. Includes pump, wall mount bracket, suction tube assembly, and spray wand.

Recommended accessories



Fluid Regulators



Material Filters



Extrusion Guns



Lubrication Meters



Siphon Hoses



Wet Sol® Packing Lubricants



ARO Stop Overrun Controls



High-Output Mufflers



Filter Regulators

Engineered simplicity

Introducing AFX air motor technology

At the heart of ARO-Force piston pumps are superior air motors, featuring our proprietary AFX technology. With only five moving parts, our air motors are truly advanced, yet simple. No other air motor out there delivers the precise performance, flexibility, and simplicity of an AFX air motor.

AFX air motors feature technology that no one else has:

- **Progressive Exhaust** — enhances pump performance
- **True Link Valve** — reduces changeover time



Simply designed

AFX air motors have around 40% fewer parts than competitive models.

- Best engineered motor on the market
- Minimised failure risk due to fewer moving parts
- Designed and constructed for easy access and maintenance
- Universal maintenance kit for all AFX air motors

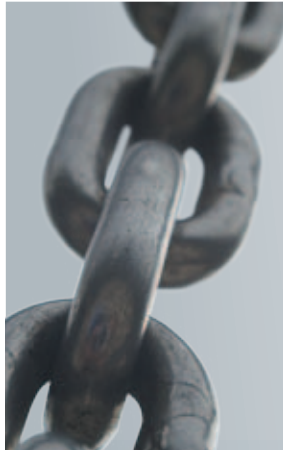

Simply reliable

Backed by a 5-year warranty, our AFX air motors perform reliably in any application.

- Progressive Exhaust enhances pump performance
- True Link Valve virtually eliminates pulse profile
- No springs to fail due to fatigue or corrosion
- Requires no lubrication and no lubricator installation



Simply safe

We incorporate important features to make our AFX air motors as safe as possible.

- Dump pressure manually
- Groundable
- ATEX-compliant
- Standard muffler

Five motor sizes, one simple approach

Whether you have a 4-1/4" motor, a 12" motor, or any in between, the ARO-Force family offers these convenient features and benefits:

- Our **universal air motor kit** can service all AFX motors. You only need to stock one, which means reduced spare-parts inventory.
- Modular design reduces downtime by making repairs quick.
- Only have to learn how to service one air motor.



12"

10"

8"

6"

4.25"

Cut-away view of AFX pump valve block featuring our innovative **Progressive Exhaust** and **True Link Valve** technology

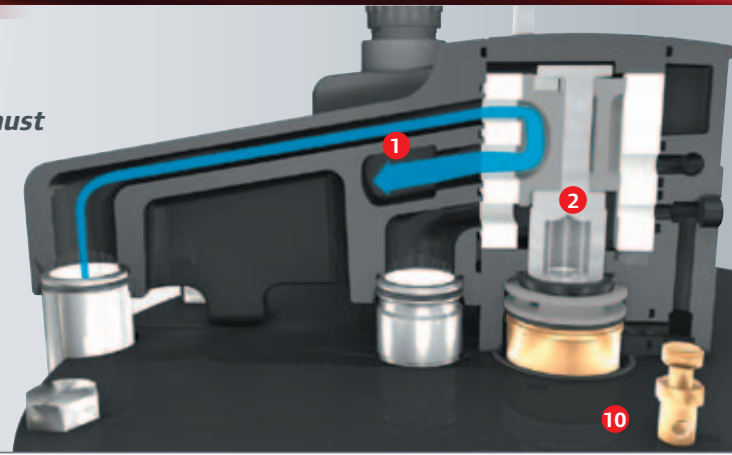

AFX reliability features:

- 1 Progressive Exhaust** Parabolic valve geometry and cascading expansion chambers practically eliminate variability in pump performance caused by changing environmental conditions or icing.
- 2 True Link Valve** Our pulse profile is virtually undetectable. Highly polished ceramic valve plates and PTFE-filled acetal valve components are directly linked to the drive piston, creating an industry-leading changeover time of less than one-tenth of a second. There are no springs to fail or consume energy. Patent pending.
- 3 Fiber-wound, conductive composite cylinder** outlasts the competition's metal cylinders with superior seal wear created by the epoxy surface; metal cylinders can seize with piston if seal failure occurs.
- 4 Lubrication-free operation** ensures peace of mind while saving you the cost of lubricating your pump.
- 5 6" stroke** results in improved performance for your process with high displacement per stroke, improved pulse profile, and reliability due to fewer switch-overs per cycle.



AFX designed simplicity features:

- 6 Universal valve block** reduces downtime since it's easily serviced and interchangeable between all motor sizes.
- 7 Universal lower end pump connection** permits interchangeability between various sized air motors and pump ratios — you can upgrade the motor without buying a new pump.
- 8 Compact design** makes it easier to incorporate our pumps into OEM equipment.
- 9 Actuation control ports** provide access for pneumatic logic signal controls. Patent pending.



AFX safety features:

- 10 Groundability** provides safe operation where static charge build-up and sparking is a concern. Our groundable pumps are ATEX-compliant. 
- 11 Optional integrated ball valve regulator** enhances safety by enabling air pressure to be set using a regulator, to be checked visually by reading the gauge, and to be dumped manually; also eliminates need for installation and expense of extra plumbing, regulators, or valves. Patent pending.

Simply better pumps

Introducing AFX pump technology

Whether your application requires a 2-ball, 4-ball, or chop-check piston pump, with ARO-Force you get a pump that's better engineered, from the inside out. We offer design features and performance enhancements that ensure your pump is as durable and dependable as possible — maximising output and minimising downtime for a long time to come.

Pump selection made simple

With an AFX piston pump, you're getting the best, most reliable equipment with the least amount of effort, calculation, or hassle on your part. There are basically four factors to take into consideration when selecting the right configuration for your application:

- ▶ **Type of fluid**
- ▶ **Viscosity or thickness**
- ▶ **Required flow rate**
- ▶ **Required output pressure**

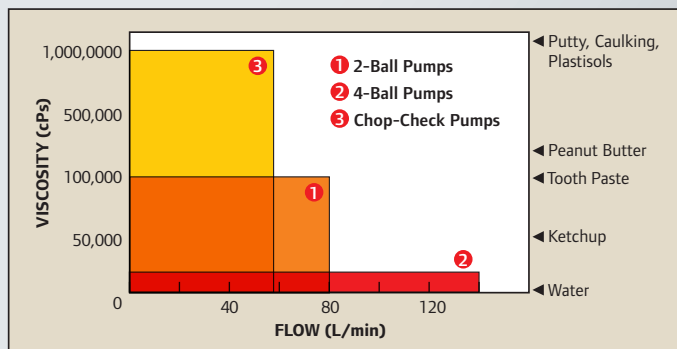

Pump selection at a glance

Knowing fluid viscosity and flow rates makes it easier to choose the right pump for your application.

Not sure what size air motor or piston pump you need? No problem. You can find out simply by calling ARO technical support and working directly with our expert pump consultants, or by visiting our website to use our interactive selection tools. Either way, you'll be sure to get a motor and pump package that operates efficiently, reliably, and safely for years to come. It's simply easier with ARO Fluid Products.



ingersollrandproducts.com/AFX



arohotline@irco.com

Best-in-class output

- **6" stroke** delivers best-in-class displacement per cycle, delivering better flow rate, better output, and less fatigue on parts.

Superior performance with abrasive fluids

- Plunger rods and cylinder tubes feature the **exclusive ARO ceramic ultra-coating**, extending service life up to twice as long. Available on 2-ball. Standard on 4-ball.
- Available in affordable **high-grade stainless-steel** construction.
- Electro-polished and passivated for material compatibility and corrosion-free operation.
- **Eight packing options** are available, including ultra-high molecular weight polyethylene (UHMW-PE), for even better material compatibility and maximum abrasion resistance.
- **Chrome-plated stainless steel plungers** for superior resistance to rust and corrosion.

Easy serviceability

- Plungers and packings are easily accessible, minimising downtime.
- Pump packings on the 2-ball pumps are adjustable, featuring a wave spring and guide arrangement.
- Parts are available in convenient service kits so you have the right parts at the right time.

2-ball pumps



Spray



Extrusion



Transfer and Supply

Materials

- Oils
- Coatings
- Paint
- Chemicals



2-ball pumps are among the most versatile in the ARO-Force line. They are capable of handling applications from simple transfer to the extrusion of low- to medium-viscosity materials up to 100,000 centipoise (cPs) with fluid delivery up to 18.1 gpm (68.6 L/min).

4-ball pumps



Transfer and Supply

Materials

- Paint
- Chemicals
- Varnishes
- Enamels
- Lacquers

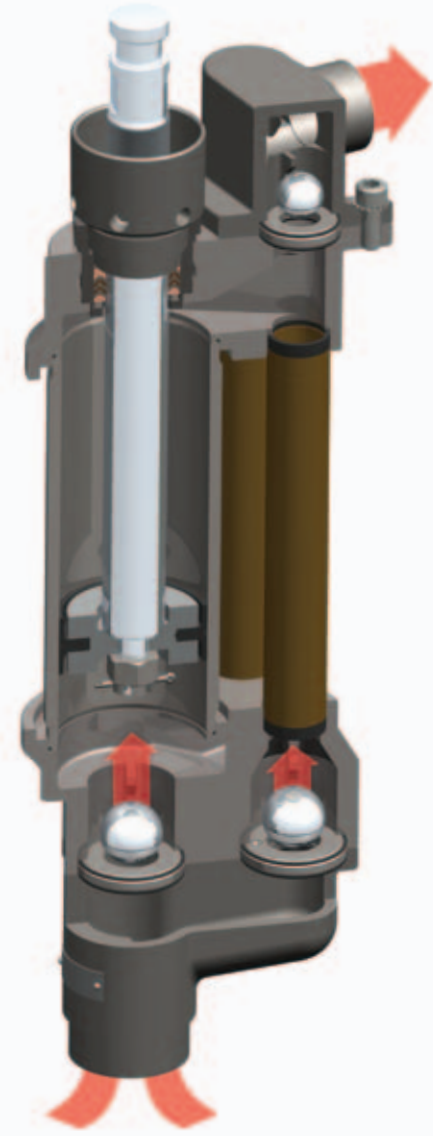

ARO-Force 4-ball piston pumps are designed to transfer high volumes of low- and medium-viscosity fluids up to 12,500 cPs with fluid delivery up to 32.8 gpm (124.0 L/min), depending on the application.

A common use involves circulating fluid from the original container, to the point of use, and then back.

Chop-check pumps



Extrusion



Transfer and Supply

Materials

- Caulking
- Heavy lubricants
- Mastics
- Sealants
- Inks



The heavy-hitters of the line, ARO-Force chop-check pumps are designed to move medium- to high-viscosity fluids ranging from 15,000 to more than 1,000,000 cPs, and at delivery rates up to 12.2 gpm (46.3 L/min).



Ingersoll Rand (NYSE:IR) advances the quality of life by creating and sustaining safe, comfortable and efficient environments. Our people and our family of brands — including Club Car®, Ingersoll Rand®, Schlage®, Thermo King® and Trane® — work together to enhance the quality and comfort of air in homes and buildings; transport and protect food and perishables; secure homes and commercial properties; and increase industrial productivity and efficiency. Ingersoll Rand products range from complete compressed air systems, tools and pumps to material handling systems. The diverse and innovative products, services and solutions enhance our customers' energy efficiency, productivity and operations. We are a \$14 billion global business committed to a world of sustainable progress and enduring results.



ingersollrandproducts.com

Distributed by:



Ingersoll Rand, IR and the IR logo are trademarks of Ingersoll Rand, its subsidiaries and/or affiliates. All other trademarks are the property of their respective owners.

Nothing contained on these pages is intended to extend any warranty or representation, expressed or implied, regarding the product described herein. Any such warranties or other terms and conditions of sale of products shall be in accordance with Ingersoll Rand's standard terms and conditions of sale for such products, which are available upon request.

Product improvement is a continuing goal at Ingersoll Rand. Designs and specifications are subject to change without notice or obligation.