

# **BALDOR**® • ***RELIANCE***

## **Product Information Packet**

# **CESSWDM3710T**

**7.5HP, 1770RPM, 3PH, 60HZ, 213TC, 3739M, TEFC**

Part Detail							
Revision:	Q	Status:	PRD/A	Change #:		Proprietary:	No
Type:	AC	Prod. Type:	3739M	Elec. Spec:	37WGT864	CD Diagram:	CD0005
Enclosure:	TEFC	Mfg Plant:		Mech. Spec:	37J639	Layout:	37LYJ639
Frame:	213TC	Mounting:	F1	Poles:	04	Created Date:	07-20-2006
Base:	RG	Rotation:	R	Insulation:	F	Eff. Date:	04-06-2015
Leads:	9#14					Replaced By:	
Literature:		Elec. Diagram:					

Nameplate NP1953C01											
CAT.NO.	CESSWDM3710T										
SPEC.	37J639T864G1										
HP	7.5										
VOLTS	230/460										
AMP	19/9.5										
RPM	1770										
FRAME	213TC					HZ	60			PH	3
SER.F.	1.15				CODE	J		DES	A	CLASS	F
NEMA-NOM-EFF	91.7					PF	81				
RATING	40C AMB-CONT										
CC	010A					USABLE AT 208V					
DE	6307					ODE	6206				
ENCL	TEFC			SN							

Parts List		
Part Number	Description	Quantity
SA147567	SA 37J639T864G1	1.000 EA
RA136608	RA 37J639T864G1	1.000 EA
37FN3002B01	EXFN, PLASTIC, 7.50 OD, 1.155 ID	1.000 EA
HW3200S01	EYEBOLT 3/8-16 X3/4 S.S. TDR #35988	1.000 EA
37CB1004A01	CONDUIT BOX, MACH	1.000 EA
37GS3011	1/8"WHITE NEOPRENE BOX GS	1.000 EA
51XW2520A12	.25-20 X .75, TAPTITE II, HEX WSHR SLTD	2.000 EA
HA5027A02	HA4054 T-DRAIN X2 BAGGED WITH LABEL	1.000 EA
11XW1032G06	10-32 X .38, TAPTITE II, HEX WSHR SLTD U	1.000 EA
HW3001B01	BRASS CUP WASHER, FOR #8 SCREW	1.000 EA
37FE1907A01	FR ENDPLATE ASSY	1.000 EA
HW4606A03	JM CLIPPER/SEAL (LWE-1156-1875-AL44)	1.000 EA
HW5100A06	W2420-025 WVY WSHR (WB)	1.000 EA
37PE1908A02	PU ENDPLATE ASSY, FOR LOCKED 307 BRG	1.000 EA
HW4606A04	JM CLIPPER/SEAL (LWE-1376-2125-AL45)	1.000 EA
10XN2520S32	1/4-20 X 2 HEX HEAD SS	4.000 EA
XY3118S12	5/16-18 HEX NUT, STAINLESS STEEL	4.000 EA
37FH4000A45	STAINLESS FAN COVER, NO GREASER SLOT (FO	1.000 EA
10XN1032S06	HEX HD CAP SCREW, SS	3.000 EA
36CB4517	LIPPED CB LID #304 STAINLESS - CLEANED	1.000 EA
37GS3010	1/16"WHITE LID GASKET	1.000 EA
59XN0832S07	8/32 X 7/16 HX WS HD SER X	4.000 EA
HW2502F21	#303 SS,SQ KEY 5/16 X 2.375	1.000 EA
HA7000A02	KEY RETAINER RING, 1 1/8 DIA, 1 3/8 DIA	1.000 EA

<b>Parts List (continued)</b>		
<b>Part Number</b>	<b>Description</b>	<b>Quantity</b>
MJ5001A02	732 CL SEALANT 3 OZ DIXIE BEARING 289100	0.001 EA
MJ1000A02	GREASE, POLYREX EM EXXON (USe 4824-15A)	0.050 LB
51XB1214A20	12-14X1.25 HXWSSLD SERTYB	1.000 EA
HA3104S30	T-BOLT, .31-18 X 13.875SSTD#100207	4.000 EA
37PA1039	PALLET PACK GRP, PRINT PK1026A06	1.000 EA
MN416A01	TAG-INSTAL-MAINT no wire (1200/bx) 11/14	1.000 EA

**AC Induction Motor Performance Data**

Record # 17300 - Typical performance - not guaranteed values

<b>Winding:</b> 37WGT864-R001	<b>Type:</b> 3739M	<b>Enclosure:</b> TEFC
-------------------------------	--------------------	------------------------

Nameplate Data				460 V, 60 Hz: High Voltage Connection	
Rated Output (HP)	7.5			Full Load Torque	22.34 LB-FT
Volts	230/460			Start Configuration	direct on line
Full Load Amps	19.0/9.5			Breakdown Torque	71.3 LB-FT
R.P.M.	1770			Pull-up Torque	38.7 LB-FT
Hz	60	Phase	3	Locked-rotor Torque	46.5 LB-FT
NEMA Design Code	A	KVA Code	J	Starting Current	73 A
Service Factor (S.F.)	1.15			No-load Current	4.3 A
NEMA Nom. Eff.	91.7	Power Factor	81	Line-line Res. @ 25°C	1.34 Ω
Rating - Duty	40C AMB-CONT			Temp. Rise @ Rated Load	69°C
S.F. Amps				Temp. Rise @ S.F. Load	87°C

Load Characteristics 460 V, 60 Hz, 7.5 HP

% of Rated Load	25	50	75	100	125	150	S.F.
Power Factor	42	65	75	81	83	84	82
Efficiency	87.4	91.6	92.2	91.9	91	89.8	91.4
Speed	1793	1786	1778	1770	1760	1750	1764
Line amperes	4.8	5.95	7.62	9.47	11.6	13.9	10.7

Performance Graph at 460V, 60Hz, 7.5HP Typical performance - Not guaranteed values

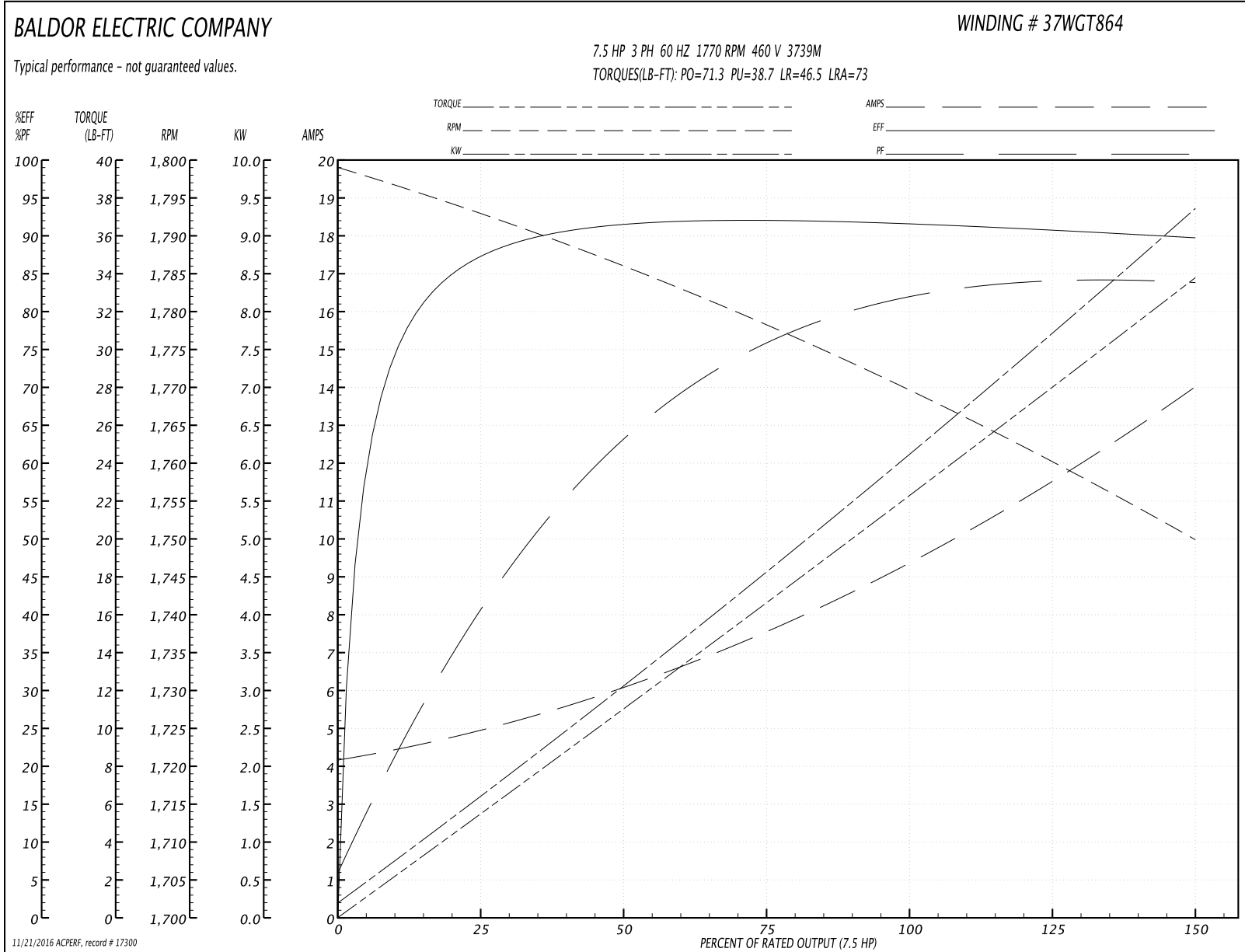

37LYJ639

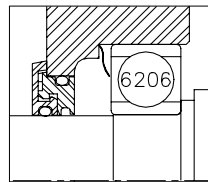
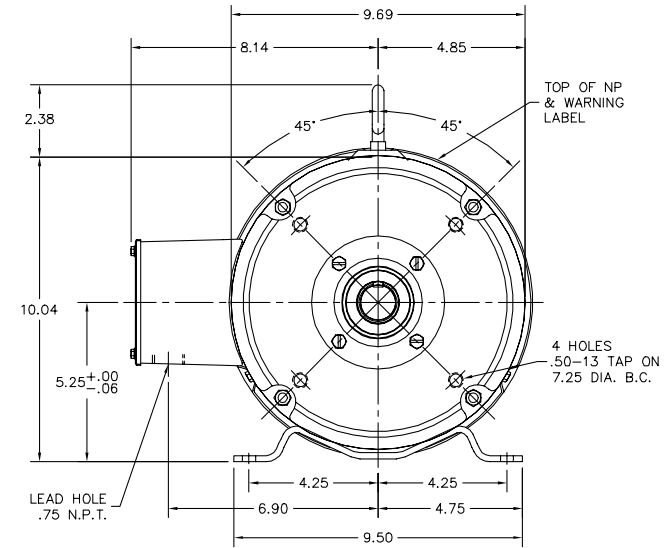
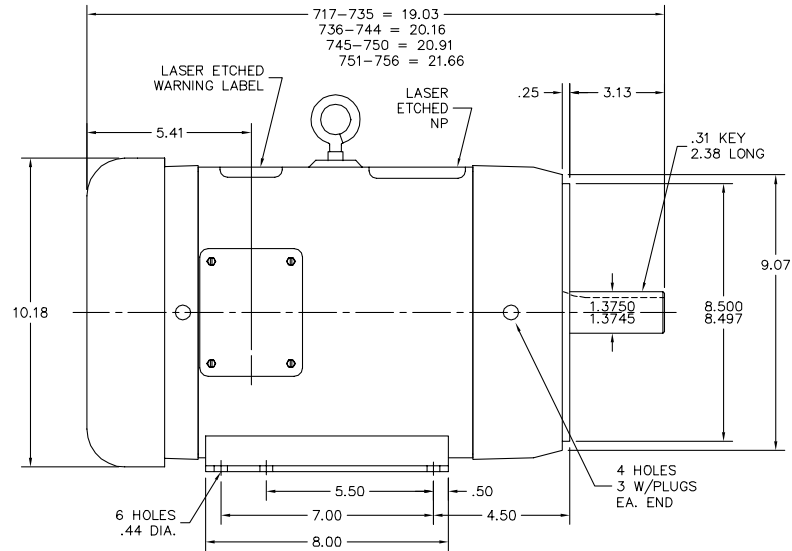

FRONT END DETAIL

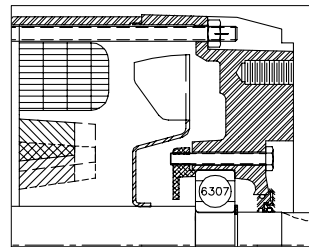

PULLEY END DETAIL

CUSTOMER IS RESPONSIBLE FOR DETERMINING THAT MOTOR PERFORMANCE IS SUITABLE IN THE APPLICATION.

REV. DESC: NEW	VERSION: 00	TDR: 000000402493
REV. LTR: -	REVISED: 12:58:39 07/19/2006	BY: ENBRYPO
FILE: \AAA\00138\592		
MTL: -		

**BALDOR ELECTRIC Co.**

STD HOR 213-5TC TEFC 37M WD4 W/LASER ETCHED BAND

37LYJ639

CD0005



LOW VOLTAGE  
(2Y)



HIGH VOLTAGE  
(1Y)

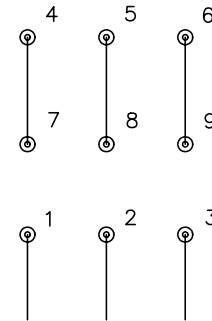

NOTES:

1. INTERCHANGE ANY TWO LINE LEADS TO REVERSE ROTATION.
2. OPTIONAL THERMOSTATS ARE PROVIDED WHEN SPECIFIED.
3. ACTUAL NUMBER OF INTERNAL PARALLEL CIRCUITS MAY BE A MULTIPLE OF THOSE SHOWN ABOVE.
4. LEAD COLORS ARE OPTIONAL. LEADS MUST ALWAYS BE NUMBERED AS SHOWN.

REV. DESC: REVISE TO SHOW OPTIONAL COLORS			
REV. LTR: E	BY: JLP	REVISED: 01/19/99 10:15	TDR: 0171435
9000D		FILE: AAA00005140	MDL: -
		MTL: -	

**BALDOR ELECTRIC Co.**

3PH, DV, 9 LEADS

CD0005