

# **BALDOR**® • ***RELIANCE***

## **Product Information Packet**

# **CL3711T**

**10HP,3450RPM,1PH,60HZ,215TC,3744LC,TEFC**

Part Detail							
Revision:	AK	Status:	PRD/A	Change #:		Proprietary:	No
Type:	AC	Prod. Type:	3744LC	Elec. Spec:	37WGW578	CD Diagram:	CD0086
Enclosure:	TEFC	Mfg Plant:		Mech. Spec:	37F395	Layout:	37LYF395
Frame:	215TC	Mounting:	F1	Poles:	02	Created Date:	
Base:	RG	Rotation:	R	Insulation:	F	Eff. Date:	09-10-2015
Leads:	2#10 A PH,2#14 B PH					Replaced By:	
Literature:		Elec. Diagram:					

Nameplate NP1256L										
CAT.NO.	CL3711T									
SPEC.	37F395W578									
HP	10									
VOLTS	230									
AMP	40									
RPM	3450									
FRAME	215TC				HZ	60			PH	1
SER.F.	1.00		CODE	H	DES	L		CLASS	F	
NEMA-NOM-EFF	82		PF	98						
RATING	40C AMB-CONT									
CC									USABLE AT 208V	
DE	6307				ODE	6206				
ENCL	TEFC			SN						

Parts List		
Part Number	Description	Quantity
SA031452	SA 37F395W578	1.000 EA
RA027491	RA 37F395W578	1.000 EA
OC3030F11SP	CYL OIL CAP 30MFD/370V	2.000 EA
EC1216C06SP	ELEC CAP, 216-259 MFD, 250V, 2.06D X 4.	3.000 EA
37EP3101A01	FR ENDPLATE, FOR ROUTING PURPOSES	1.000 EA
HW4500A01	1641B(ALEMITE)400 UNIV, GREASE FITT	1.000 EA
13XF0832A08	8-32 X.50 PAN HD,SLTD, TYPE F SCREW, ZIN	2.000 EA
37CB5001A21	ENCL, A01 BOX W/LID, GASKETS & 1.09 LEAD	1.000 EA
HW5100A06	W2420-025 WVY WSHR (WB)	1.000 EA
37PE3300A01	PUEP ASSEMBLY FOR ROUTING	1.000 EA
HW4500A01	1641B(ALEMITE)400 UNIV, GREASE FITT	1.000 EA
10XN2520A30	HEX HD CAP SCREW-STD THD-.25 X 20 THD PE	4.000 EA
HW1001A25	LOCKWASHER 1/4, ZINC PLT .493 OD, .255 I	4.000 EA
XY3118A12	5/16-18 HEX NUT DIRECTIONAL SERRATION	4.000 EA
37FN3002A01SP	EXFN, PLASTIC, 9.00 OD, 1.155 ID	1.000 EA
51XB1214A20	12-14X1.25 HXWSSLD SERTYB	1.000 EA
07FH4007A06	IEC FH W/GRS, NOT @6, 3 F/C HOL & NOT FO	1.000 EA
51XW1032A06	10-32 X .38, TAPTITE II, HEX WSHR SLTD S	3.000 EA
HW2501F21	KEY, 5/16 SQ X 2.375	1.000 EA
HA7000A02	KEY RETAINER RING, 1 1/8 DIA, 1 3/8 DIA	1.000 EA
LB1115N	LABEL,LIFTING DEVICE (ON ROLLS)	1.000 EA
85XU0407S04	4X1/4 U DRIVE PIN STAINLESS	2.000 EA
HW3200A01	3/8-16X3/4 I-BLT WELDED F/S	1.000 EA
MJ1000A02	GREASE, POLYREX EM EXXON (USe 4824-15A)	0.050 LB

<b>Parts List (continued)</b>		
<b>Part Number</b>	<b>Description</b>	<b>Quantity</b>
MG1000G27	MED CHARCOAL METALLIC GREY 400-0096	0.028 GA
WD1000A15	3-520132-2 AMP FLAG (4M/RL NON-CANC/NON-	10.000 EA
SP5172A11	37 TYPE L TORQ STAT SWITCH LEAD ASSEMBLY	1.000 EA
NS2539	INSULATOR FOR 37 FRAMESWITCH (MH1011A10)	1.000 EA
HA3104A17	5/16-18X13.250 T-BLT/OHIO	4.000 EA
LB1119N	WARNING LABEL	1.000 EA
LC0086	CONNECTION LABEL	1.000 EA
NP1256L	ALUM UL CSA CC	1.000 EA
37PA1039	PALLET PACK GRP, PRINT PK1026A06	1.000 EA
MN416A01	TAG-INSTAL-MAINT no wire (1200/bx) 11/14	1.000 EA

**AC Induction Motor Performance Data**

Record # 11882 - Typical performance - not guaranteed values

<b>Winding:</b> 37WGW578-R001	<b>Type:</b> 3744LC	<b>Enclosure:</b> TEFC
-------------------------------	---------------------	------------------------

Nameplate Data				230 V, 60 Hz: Single Voltage Motor	
Rated Output (HP)	10			Full Load Torque	15 LB-FT
Volts	230			Start Configuration	direct on line
Full Load Amps	40			Breakdown Torque	44 LB-FT
R.P.M.	3450			Pull-up Torque	33 LB-FT
Hz	60	Phase	1	Locked-rotor Torque	42 LB-FT
NEMA Design Code	L	KVA Code	H	Starting Current	284 A
Service Factor (S.F.)	1			No-load Current	4.3 A
NEMA Nom. Eff.	82	Power Factor	98	Line-line Res. @ 25°C	0.174 Ω A Ph 0.681 Ω B Ph
Rating - Duty	40C AMB-CONT			Temp. Rise @ Rated Load	102°C

Load Characteristics 230 V, 60 Hz, 10 HP

% of Rated Load	25	50	75	100	125	150
Power Factor	99	99	99	99	98	97
Efficiency	66.6	78.9	82.9	83.9	83.4	81.8
Speed	3573	3551	3527	3500	3469	3431
Line amperes	12.2	20.6	29.5	39	49.4	61.1

Performance Graph at 230V, 60Hz, 10.0HP Typical performance - Not guaranteed values

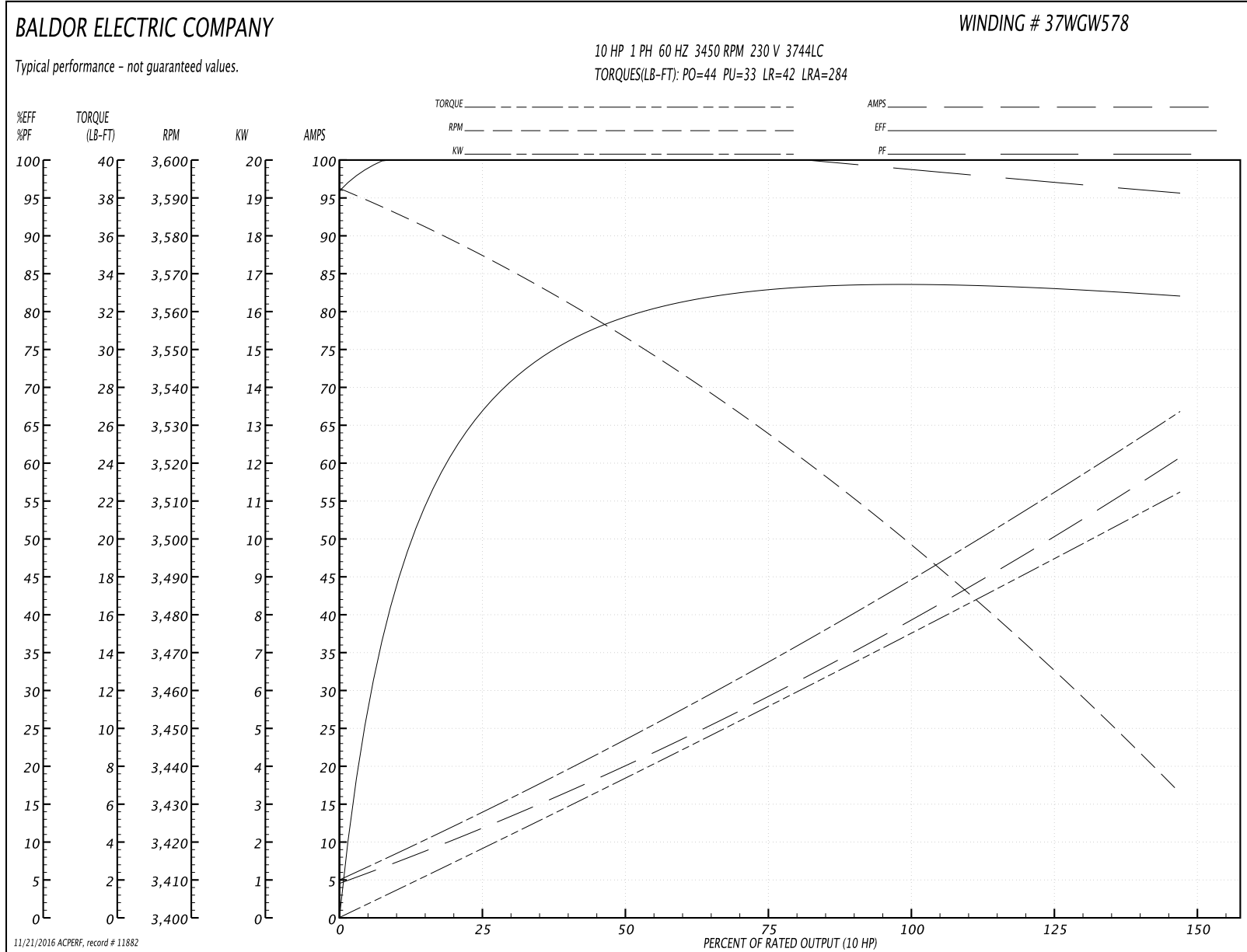

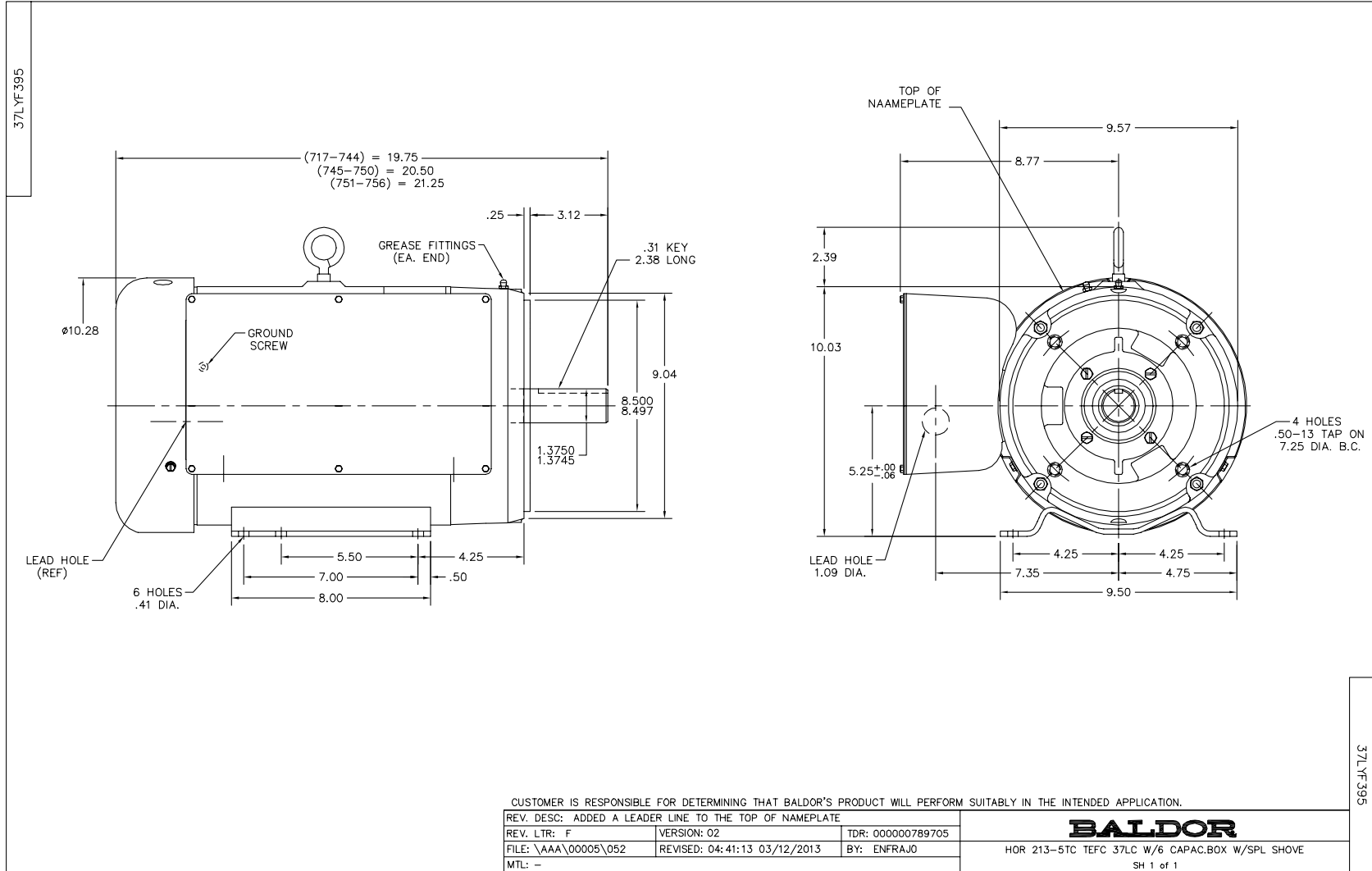

CD0086

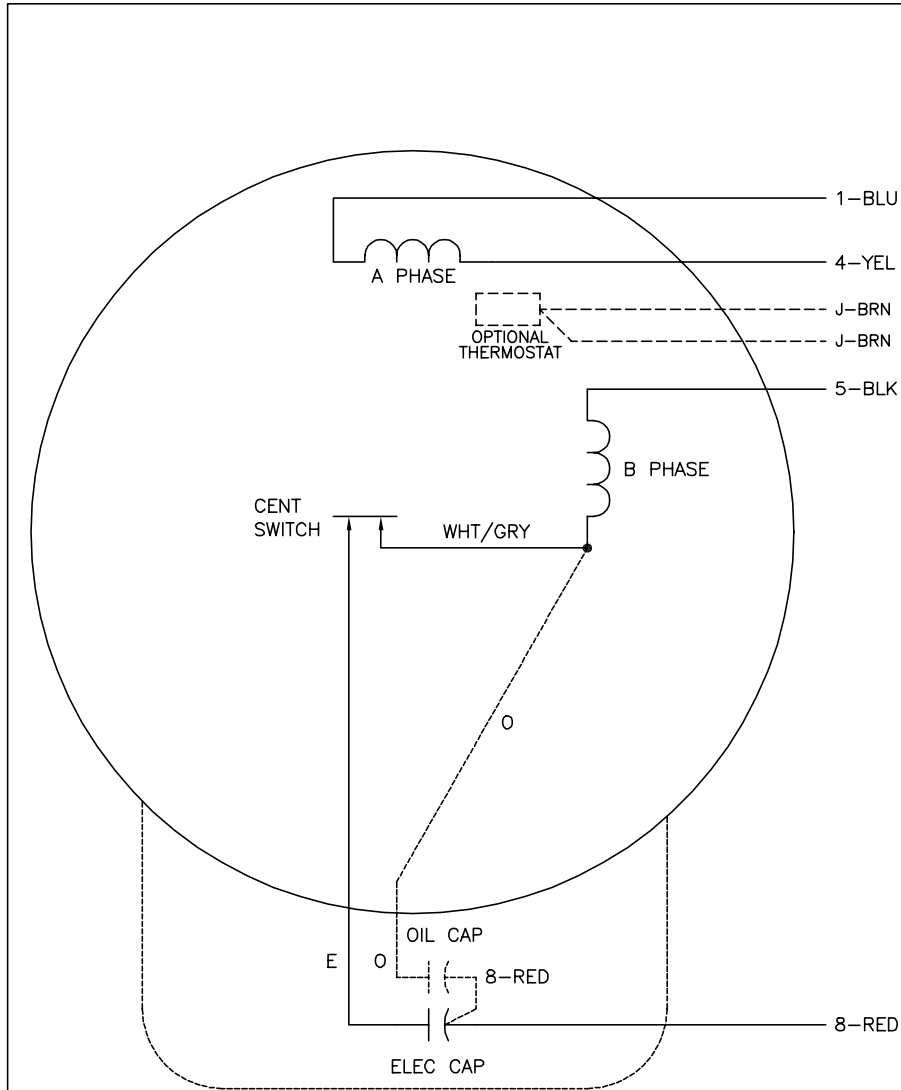

	LINE A	LINE B
STD	1,8	4,5
OPP	1,5	4,8

NOTES:

1. STANDARD ROTATION IS CCW FACING END OPPOSITE SHAFT EXTENSION.
2. OPTIONAL THERMOSTAT IS PROVIDED WHEN SPECIFIED.
3. MULTIPLE CAPACITORS ARE CONNECTED IN PARALLEL UNLESS OTHERWISE SPECIFIED.
4. OPTIONAL OIL CAPACITOR IS PROVIDED WHEN SPECIFIED.
5. CAPACITORS MAY BE SEPERATELY MOUNTED.
6. LEAD COLORS ARE OPTIONAL. LEADS MUST ALWAYS BE NUMBERED AS SHOWN.

REV. DESC: ADDED CK TO PLANT CODE			
REV. LTR: F	BY: JD	REVISED: 16:01:12 01/07/2002	TDR: 259409
98000D		FILE: AAA00026904	REF: CD0086
		MTL: -	

**BALDOR ELECTRIC Co.**

TYPE L OR LC, SV, REV, 4 LEADS, CAPS MAY BE SEP MTD

CD0086