

BALDOR® • ***RELIANCE***

Product Information Packet

ECTM4103T

25 AIR OVERHP,1770RPM,3PH,60HZ,284T,1046

Part Detail							
Revision:	D	Status:	PRD/A	Change #:		Proprietary:	No
Type:	AC	Prod. Type:	1046M	Elec. Spec:	10WGX209	CD Diagram:	CD0005
Enclosure:	TEAO	Mfg Plant:		Mech. Spec:	10K189	Layout:	10LYK189
Frame:	284T	Mounting:	F1	Poles:	04	Created Date:	08-17-2015
Base:	RG	Rotation:	R	Insulation:	F	Eff. Date:	01-04-2017
Leads:	9#10					Replaced By:	
Literature:		Elec. Diagram:					

Nameplate NP1260E			
CAT.NO.	ECTM4103T		
SPEC.	10K189X209G1		
HP	25 AIR OVER		
VOLTS	230/460		
AMP	60/30		
RPM	1770		
FRAME	284T	HZ	60
SER.F.	1.15	CODE	G
NEMA-NOM-EFF	93.6	DES	A
RATING	40C AMB-CONT	PF	84
CC		PH	3
DE	6311	CL	F
ENCL	TEAO	ODE	6309
	2050 FPM @ 520CFM	USABLE AT 208V	63.3
		SN	

Parts List		
Part Number	Description	Quantity
SA305639	SA 10K189X209G1	1.000 EA
RA292865	RA 10K189X209G1	1.000 EA
S/P107-000-004	SUPER-E(284 FR. & UP)-CL PLANT,POLYREX E	1.000 EA
10CB1000A132E	SPL KOBX W/E-COAT	1.000 EA
HA4044A00	PLUG,PIPE 1/8 NPT PLASTIC SQUARE HEAD	2.000 EA
09GS1010	GASKET, DWG, LEADWIRE SEPERATOR	1.000 EA
10XN3118K16	5/16-18 X 1' GRADE #5, STL, ZINC PLATE	4.000 EA
HW1001A31	LOCKWASHER 5/16, ZINC PLT .591 OD, .319 I	4.000 EA
WD1000B16	T&B CX70TN TERMINAL	1.000 EA
10XN2520K06	1/4-20 X 3/8" HX HD SCREWGRADE 5, ZINC P	1.000 EA
HW1001A25	LOCKWASHER 1/4, ZINC PLT .493 OD, .255 I	1.000 EA
10EP1104A109E	FREP MACH W/E-COAT,NO GRSR & RELIEF,	1.000 EA
HA7205	"L" SHAPE LIFTING LUG FOR 37,39 & 40 FRA	2.000 EA
10XN3816K28	3/8-16 X 1.75 HEX HD CAP SCREW, GRADE 5	4.000 EA
HW1001A38	LOCKWASHER 3/8, ZINC PLT .688 OD, .382 I	4.000 EA
HW5100A11	W3917-042 WVY WSHR (WB)	1.000 EA
10EP1105A129E	PUEP MACH W/E-COAT,LESS GRSR,DRAIN @ 3&9	1.000 EA
10XN3816K28	3/8-16 X 1.75 HEX HD CAP SCREW, GRADE 5	4.000 EA
HW1001A38	LOCKWASHER 3/8, ZINC PLT .688 OD, .382 I	4.000 EA
HW4600A49	CR #20643 SINGLE LIP SEAL	1.000 EA
HW4600B40	V-RING SLINGER 2.000 X 2.680 X .28 VITON	1.000 EA
HW4600G54	DOME SLINGER, 7.125 OD X 1.870/1.810 ID	1.000 EA
10XN3118K40	5/16-18 X 2.50" HEX HD, GRADE 5	4.000 EA
10CB1503A01P	CONDUIT BOX LIPPED LID, MACH W/EPXY PRMR	1.000 EA

Parts List (continued)		
Part Number	Description	Quantity
14GS1003	GASKET CONDUIT BOX LID, NEOP	1.000 EA
10XN2520K16	1/4-20 X 1" HX HD SCRW GRADE 5, ZINC P	4.000 EA
HW1001A25	LOCKWASHER 1/4, ZINC PLT .493 OD, .255 I	4.000 EA
HW2501H28	KEY, 1/2 SQ X 3.250	1.000 EA
MJ5001A27	32220KN GRAY SEALER *MIN BUY 4 QTS=1GAL	0.031 QT
MJ5001A14	DYNAPRO SEAL, CP MOTORS VC#2508050 (603	0.033 EA
MJ5002A01	SILICON RUBBER SEALANT, 732CL 10.3 OZ TU	0.025 EA
LB1115N	LABEL,LIFTING DEVICE (ON ROLLS)	1.000 EA
LB1182	WARNING LABEL FOR MOTORS WITH EYENUTS	1.000 EA
LB1002N	LABEL,MARINE DUTY (ON ROLLS)	1.000 EA
HA4054	SHORT T-DRAIN FITTING, .125" N.P.T.	3.000 EA
MJ1000A02	GREASE, POLYREX EM EXXON (USe 4824-15A)	0.130 LB
HA4054	SHORT T-DRAIN FITTING, .125" N.P.T.	3.000 EA
MG1025G05	WILKOFASST, 789.227, MED. GRAY CHAR. MET.	0.070 GA
85XU0407S04	4X1/4 U DRIVE PIN STAINLESS	2.000 EA
LC0005E02	SPL CONN.DIA./WARN.LABEL(LC0005/LB1119)	1.000 EA
NP1260E	SS CP SUPER-E UL CSA CC	1.000 EA
10PA1000	PACKAGING GROUP COMBINED PRINT PK1023A06	1.000 EA
MN416A01	TAG-INSTAL-MAINT no wire (1000/bx) 11/14	1.000 EA
LB1417	LABEL CARTON 6X4 PERFORATED BLANK ROLLS	1.000 EA

AC Induction Motor Performance Data

Record # 52133 - Typical performance - not guaranteed values

Winding: 10WGX209-R052	Type: 1046M	Enclosure: TEAO
-------------------------------	--------------------	------------------------

Nameplate Data				460 V, 60 Hz: High Voltage Connection	
Rated Output (HP)	25 AIR OVER			Full Load Torque	74.2 LB-FT
Volts	230/460			Start Configuration	direct on line
Full Load Amps	60/30			Breakdown Torque	235 LB-FT
R.P.M.	1770			Pull-up Torque	98.1 LB-FT
Hz	60	Phase	3	Locked-rotor Torque	123 LB-FT
NEMA Design Code	A	KVA Code	G	Starting Current	186 A
Service Factor (S.F.)	1.15			No-load Current	11.3 A
NEMA Nom. Eff.	93.6	Power Factor	84	Line-line Res. @ 25°C	0.307 Ω
Rating - Duty	40C AMB-CONT			Temp. Rise @ Rated Load	52°C
S.F. Amps				Temp. Rise @ S.F. Load	63°C
				Locked-rotor Power Factor	33
				Rotor inertia	3.66 LB-FT ²

Load Characteristics 460 V, 60 Hz, 25 HP

% of Rated Load	25	50	75	100	125	150	S.F.
Power Factor	50	73	81	85	86	85	86
Efficiency	88.7	92.3	93.5	93.6	93.1	92	93.3
Speed	1793	1785	1779	1771	1763	1755	1766
Line amperes	13.3	17.6	23.3	29.6	36.5	44.2	33.7

Performance Graph at 460V, 60Hz, 25.0HP Typical performance - Not guaranteed values

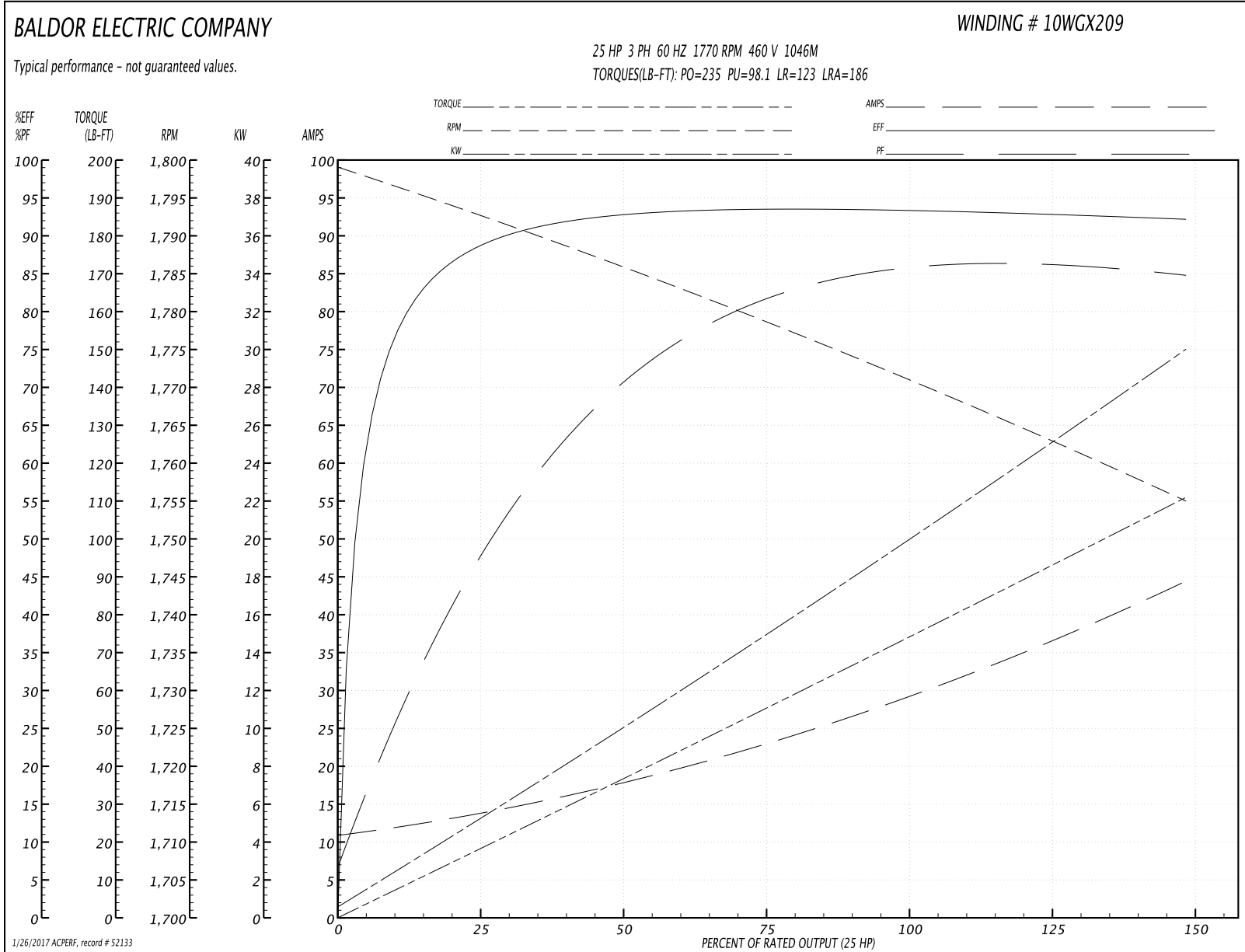

10LYK189

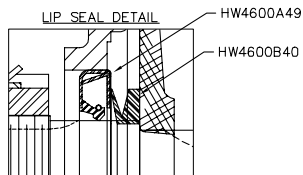
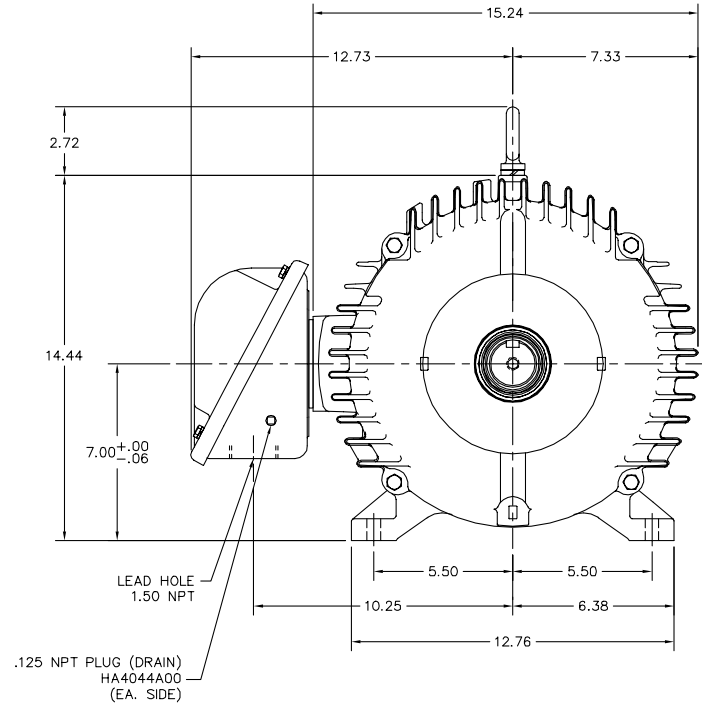
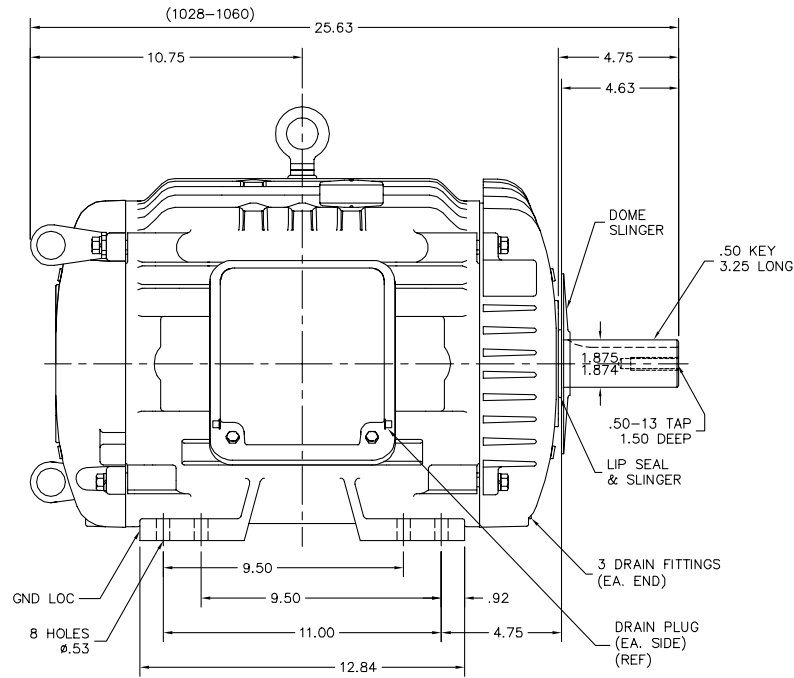

CUSTOMER ONLY NOTE: FOR VERTICAL SHAFT UP LIFTING, REMOVE EYEBOLT FROM TOP OF MOTOR AND SCREW INTO END OF SHAFT.

CUSTOMER IS RESPONSIBLE FOR DETERMINING THAT BALDOR'S PRODUCT WILL PERFORM SUITABLY IN THE INTENDED APPLICATION.

REV. DESC: NEW	VERSION: 00	TDR: 000000936345
REV. LTR: -	REVISED: 08:11:35 08/17/2015	BY: ENKENHG
FILE: \AAA\00220\838		
MTL: -		

BALDOR

HOR TEAO 284-6T CP COOLING TOWER W/SLD BRGS,VER LIF, LIP SL
SH 1 of 1

68LYK101

CD0005



LOW VOLTAGE
(2Y)

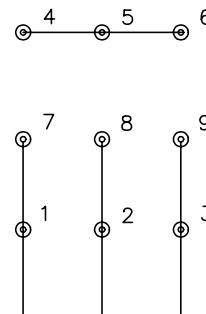

LINE

HIGH VOLTAGE
(1Y)



LINE

NOTES:

1. INTERCHANGE ANY TWO LINE LEADS TO REVERSE ROTATION.
2. OPTIONAL THERMOSTATS ARE PROVIDED WHEN SPECIFIED.
3. ACTUAL NUMBER OF INTERNAL PARALLEL CIRCUITS MAY BE A MULTIPLE OF THOSE SHOWN ABOVE.
4. LEAD COLORS ARE OPTIONAL. LEADS MUST ALWAYS BE NUMBERED AS SHOWN.

REV. DESC: REVISE TO SHOW OPTIONAL COLORS			
REV. LTR: E	BY: JLP	REVISED: 01/19/99 10:15	TDR: 0171435
9000D		FILE: AAA00005140	MDL: -
		MTL: -	

BALDOR ELECTRIC Co.

3PH, DV, 9 LEADS

CD0005