

Long Coupled-End Suction Pump

Grundfos NK

The NK range delivers industry-leading efficiencies that leave you prepared even for future efficiency regulations. With a back pull-out design and a revolutionary hard-faced seal, the NK pump is designed

for easy serviceability and improved reliability that minimizes the annual service costs throughout the lifetime of the pump. The NK delivers on the Grundfos promise – it's in everyone's comfort zone.

Key Features and Benefits

Installation

The sturdy NK base frame design ensures long-lasting alignment of the pump and motor. The sturdy frame provides a foundation for non-grouting NK pumps using motors that operate at 6 pole, 4 pole and 2 pole speeds below 60 HP. Grouting is only recommended for pumps operating with 2 pole motors above 50 HP. Loose flange design for inlet/outlet of Class 300 versions improves installation time and safety and prevents leakages at flanges. Top centerline discharge design allows for self-venting and more compact piping designs.

Efficiency & Reliability

Industry-leading efficiencies you can count on, based on advanced Computational Fluid Dynamics (CFD). NEMA Premium efficiency is standard, ROI and lower energy consumption give you a more sustainable, cost-effective installation. Silicon Carbide/Silicon Carbide (SiC/SiC) hard-faced seal has a new, revolutionary robust design that offers increased temperature range, better handling of abrasives and a longer life in comparison to standard designs. No worries about undue wear and tear on mechanical seals and bearings or energy losses due to misalignment, since the NK bearing bracket design allows it to be produced with a single manufacturing process, eliminating the usual reasons for misalignment within a long-coupled pump. Optimized, stainless-steel impeller design increases efficiency and reduces the NPSH that's required. Balanced impellers reduce noise and vibration enabling quiet operation and prolong the life of seals and bearings. Larger models have an internal dual-volute design that

increases efficiency, lowers life-cycle costs and prolongs the life of seals and bearings. Integrally cast diffuser vane reduces inlet turbulence.

Serviceability

Foot-mounted volute for increased pump stability. Long-coupled pump design allows for pump service without removing the pump housing from the pipework. Optional spacer-coupling design allows for back pull-out and easy access to the mechanical seal and impeller without removing the motor or disturbing the piping.

Applications

- HVAC (Cooling/Heating)
- District Energy
- Industrial
- Water Utility

GRUNDFOS 

Possibility in every drop

Technical Data

NK	
Flow, Q	Max 5,800 gpm
Head H	Max. 450 ft
Liquid Temperature	-13° F to +248°F (Optional 284°F)
Working Pressure	Max. 232 psi (Optional 362 psi)
HP Range	Max. 250 hp
Speed	3600, 1800 and 1200 rpm
Discharge Sizes	1.25-10 in Centerline: 1.25-6 in Tangential: 8-10 in

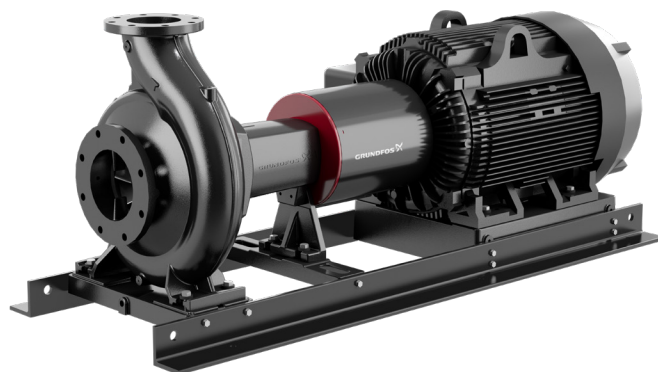

Performance Data NK 60Hz

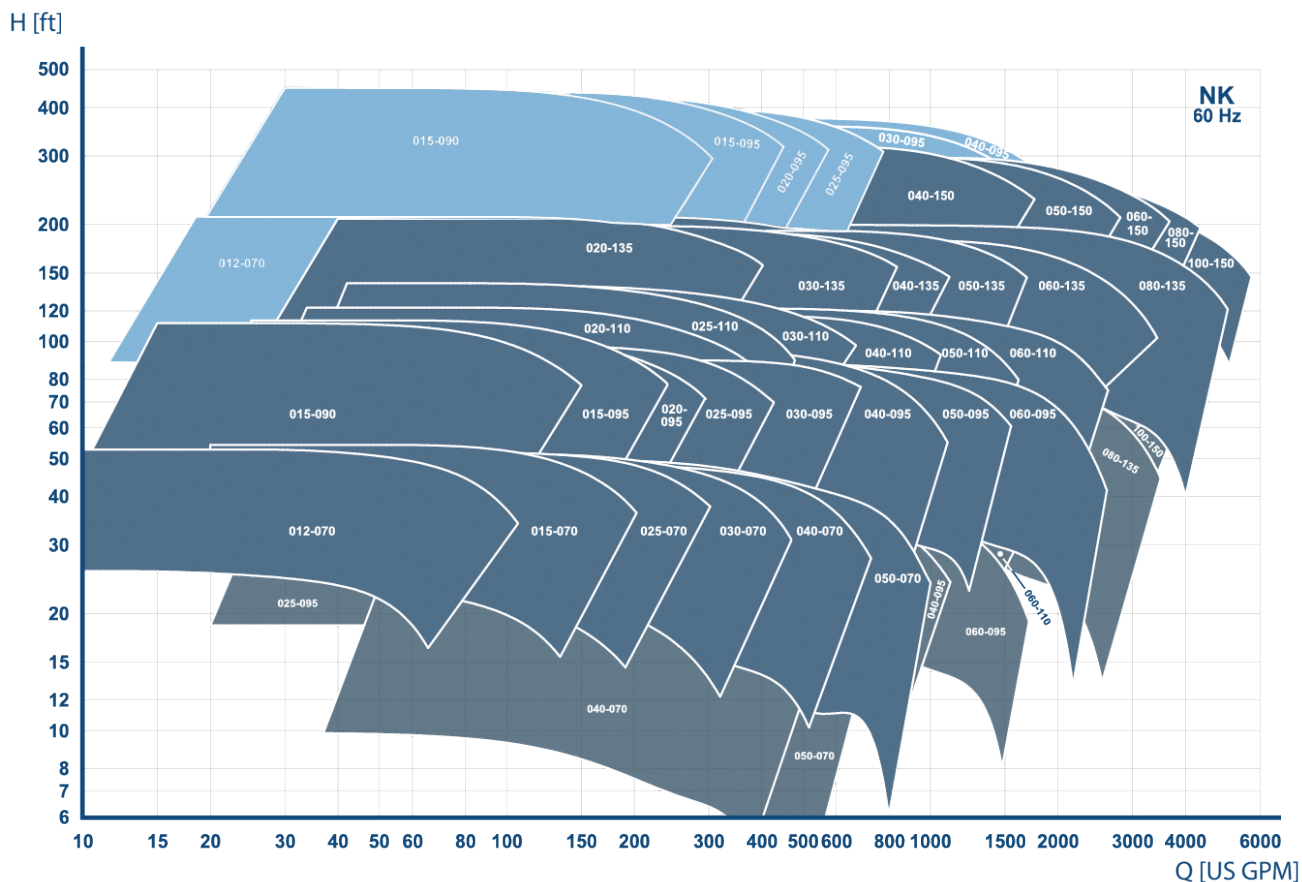

Visit grundfos.us/pei to learn more about Department of Energy (DOE) pump energy index (PEI) requirements and PEI ratings on specific Grundfos models.