

TP

Direct-coupled in-line single stage circulator pumps
60 Hz



1. Product introduction	3
Introduction	3
Pump energy index	3
Applications	3
Cross reference guide: B&G, Taco and Armstrong to Grundfos	4
Features and benefits	5
Identification	6
2. Product overview	7
Performance range, TP	7
	7
Product range, TP	8
3. Construction	9
Construction, TP	9
Material specification, TP	9
	9
Sectional drawing, TP	9
4. Operating conditions	10
Operating conditions	10
5. Installation	11
Mechanical installation	11
6. Product selection	12
Pumped liquids	12
List of pumped liquids	12
7. Curve charts/ technical data	14
Guidelines to the curve charts	14
	15
8. Accessories	26
Packaged flange sets«	26
TP optional shaft seal kits	26
9. Motors (electrical data)	27
TP TEFC motors	27
10. Submittal data	29
11. Grundfos Product Center	30
Grundfos GO	31

1. Product introduction

Introduction

Grundfos TP circulator pumps are designed for circulation of liquids in heating and air-conditioning systems. Pumps with bronze pump housings are suitable for circulation in domestic hot water systems.

Grundfos TP pumps are vertical single-stage in-line centrifugal pumps of the close-coupled type.

The TP is highly reliable and efficient. TP pumps are electrocoated to ensure a high corrosion resistance.

Pump energy index

Pump Energy Index (PEI) was established by the U.S. Department of Energy (DOE) and adopted by Canada as the standard metric used to evaluate pump efficiency. The value is the ratio of the pump efficiency rating (PER) divided by the calculated minimally compliant PER (PER_{STD}) for the pump type. This provides a representation of a pump's actual performance compared to the minimal standard performance required by regulation. The lower the PEI value, the more efficient a pump is at the tested operating points.

PER is determined by defined testing parameters required by the DOE. This includes testing a particular pump model at its best efficiency point (BEP).

For PEI values there are two different versions:

- PEI_{CL} (constant load): Applies to a bare-shaft pump, and a pump sold with a motor
- PEI_{VL} (variable load): Applies to pumps sold with a motor and controller (such as VFD, VSD)

The DOE has set the maximum PEI value as 1.00. Any pump, pump and motor, or pump, motor and controller that exceeds a PEI value of 1.00 can no longer be manufactured after January 26, 2020.

PEI is a generalized efficiency value. PEI cannot be used to determine the efficiency of a pump in a specific application.

Pump type	Pole	PEI_{CL} bare-shaft pump	PEI_{CL} pump with motor	Impeller diameter [in (mm)]
TP 40-240		0.86	0.86	3.86 (98)
TP 50-160		0.91	0.91	3.43 (87)
TP 50-240	2	0.91	0.91	3.95 (100)
TP 80-160		0.89	0.89	3.56 (90)
TP 80-240		0.88	0.89	4.00 (102)
TP 100-160		0.89	0.89	3.72 (94)
TP 80-80	4	0.93	0.93	5.03 (128)
TP 100-80		0.94	0.94	5.23 (133)

Applications

General examples of systems in which TP pumps are suitable are:

- boiler/hydronic heating
- chilled water
- air conditioning systems
- cooling towers
- domestic hot water
- radiant floor heat
- solar
- snow melt systems.



TM03 6199

Fig. 1 Grundfos TP circulator pump

Cross reference guide: B&G, Taco and Armstrong to Grundfos

B&G Series 60&80	Hp	Port to port length [in]	Flange size	Taco Series 1600	Hp	Port to port length [in]	Flange size	Armstrong	Hp	Port to port length [in]	Flange size	Grundfos Model TP	Hp	Port to port length [in]	Flange size
								H-32	.17	8.5	1.25"	32-40	.33	11.0	1.25"
6011	.25	11.0	1.25"	1600	.25	10.25	1.5"	H-52	.33	11.5	1.25"	32-80	.5	11.0	1.25"
6016	.75	13.5	1.5"	1614	.75	13.5	1.5"	H-64	.75	13.5	1.5"	32-160	.75	13.5	1.5"
								H-52	.33	11.5	.25"	40-40	.33	13.5	1.5"
								H-53	.5	11.5	1.5"		.5	13.5	1.5"
6013	.5	11.5	1.5"	1612	.5	13.5	1.5"	H-53	.5	11.5	1.5"	40-80	.75	13.5	1.5"
6015	.5	13.5	1.5"	1612	.5	13.5	1.5"	H-63	.5	13.5	1.5"	40-80	.75	13.5	1.5"
								H-67	1	14.0	2"	40-160	.75	11.5	1.5"
6017	1	13.5	1.5"	1616	1.5	14.5	2"	H-65	1	13.5	1.5"	40-240	1.5	13.5	1.5"
								H-53	.5	11.5	1.5"	50-40	.33	14.0	2"
								H-54	.75	11.5	2"		.75	11.5	2"
6014	.75	11.5	2"	1632	.75	13.5	2"	H-54	.75	11.5	2"	50-80	.75	11.5	2"
6019	1	14.0	2"	1634	1	13.5	2"	H-67	1	14.0	2"	50-160	1.5	14.0	2"
6020	1.5	14.0	2"	1634	1	13.5	2"	H-68	1.5	14.0	2"	50-160	1.5	14.0	2"
6021	2	14.0	2"					10603D	3	18.0	3"	50-240	2	14.0	2"
								105028	.5	11.5	2"	80-40	.5	19.0	3" ANSI
801	1.5	19.0	3" ANSI					10603D	1.5	18.0	3"	80-80	1.5	19.0	3" ANSI
802	3	19.0	3" ANSI					10603D	3	18.0	3"	80-160	3	19.0	3" ANSI
803	3	19.0	3" ANSI					10603D	3	18.0	3"	80-240	3	19.0	3" ANSI
								10603D	1	18.0	3"	100-40	1	21.0	4" ANSI
806	2	21.0	4" ANSI					10603D	2	18.0	3"	100-80	2	21.0	4" ANSI
807	3	21.0	4" ANSI					10603D	3	18.0	3"	100-160	3	21.0	4" ANSI

Features and benefits

Motor

The motor is a totally enclosed, fan-cooled standard motor with main dimensions to NEMA standards.

Mounting designation: NEMA C FACE

Enclosure class: TEFC; (ODP) optional

Insulation class: F, B

Ambient temperature: Max. 104 °F (40 °C).

Pump

In-line cast iron or bronze spiral pump housing.

Flange dimensions for USA are according to Industry and/or ANSI Standard.

The flanges have ¼" NPT pressure gauge tapings.

Tapped holes are provided on the underside of the pumps. These holes can be used for fitting the pump to a base plate, bracket or the like by means of hexagon screws. The pump housing is provided with a replaceable stainless steel/Teflon neck ring. The ring reduces to a minimum the amount of liquid running from the discharge side of the impeller to the suction side.

Surface treatment

The pump housing and the motor stool are electrocoated.

The treatment includes:

1. Alkaline cleaning.
2. Pre-treatment with zinc phosphate coating.
3. Cathodic electrocoating (epoxy).
Coating thickness: 15-20 µm.
4. Curing of paint film at 392 - 482 °F (200-250 °C).

Motor stool

The motor stool forms connection between the pump housing and the motor, and is equipped with a manual air vent screw for venting of the pump housing and the shaft seal chamber. The sealing between motor stool and pump housing is either an O-ring or a flat gasket.

The central part of the motor stool is provided with guards for protection against shaft and coupling.

The dimensions of the motor side flange of the motor stool are according to NEMA.

Pump shaft

The shaft is a cylindrical Ø16 mm stainless steel shaft. The coupling end of the shaft has a hole for the coupling shaft pin.

Coupling

The coupling is a two-piece, inelastic sintered metal coupling secured with four hexagon socket head screws.

Impeller

The impeller is made of stainless steel, AISI 304 SS.

As the impeller is made of stainless steel sheet, it can be pressed into the correct hydraulic form.

Shaft seal

The pumps are fitted as standard with a single, unbalanced tungsten carbide/carbon rubber bellows shaft seal in a 16 mm diameter size with EPDM elastomer (BUBE). The tungsten carbide/carbon shaft seal has a wide range of applications and is especially suitable where there is a risk of dry running and in case of high temperatures.

The tungsten carbide/carbon shaft seal is not suitable for liquids containing abrasive particles, as the carbon parts will be worn down. In that case a tungsten carbide/ tungsten carbide seal is recommended.

Optional shaft seals available:

- unbalanced tungsten carbide/tungsten carbide O-ring shaft seal with EPDM elastomer (AUUE).

And for glycol/water mixtures:



Unbalanced reduced face tungsten carbide/tungsten carbide O-ring shaft seal with EPDM elastomers (RUUE).

The circulation of liquid through the duct of the air vent screw ensures lubrication and cooling of the shaft seal.

Identification

Type key, TP

Example	TP	32	-40	/4	-A	-G	-A	-BUBE	-C	X	4
Pump range											
Nominal flange diameter [mm]											
Max. head [dm]											
Number of motor poles											
Code for pump version. The codes may be combined											
Code for pipe connection											
Code for materials											
Code for shaft seal including other plastic and rubber pump parts, except the neck ring											
Code for motors [Hp (kW)]											
Code for phase and voltage (V)											
Code for speed variant (rpm)											

Key to codes

Code	Description
Codes for pump version. The codes may be combined	
A	Basic version
B	Oversize motor
E	With ATEX approval, certificate or test report, the second character of the code for pump version is an E.
X	Special version
Codes for pipe connection	
G	ANSI flange
Codes for materials	
A	Basic version
I	Stainless steel 1.4308 pump housing and motor stool
Z	Bronze pump housing and motor stool
Codes for shaft seal	
	Grundfos type designation
A	O-ring seal with fixed seal driver
B	Rubber bellows seal
D	O-ring seal, balanced
G	Bellows seal with reduced seal faces
R	O-ring seal with reduced seal faces
	Material of rotating face
A	Carbon, antimony-impregnated
B	Carbon, resin-impregnated
Q	Silicon carbide
	Material of stationary seal
B	Carbon, resin-impregnated
Q	Silicon carbide
U	Tungsten carbide
	Material of secondary seal
E	EPDM
P	NBR rubber
V	FKM
F	FXM
Codes for motors [Hp (kW)]	
C	0.33 (0.25)
D	0.5 (0.37)
E	0.75 (0.55)

Code	Description
F	1 (0.75)
G	1.5 (1.1)
H	2 (1.5)
I	3 (2.2)
Codes for phase and voltage (V)	
X	Not defined or no motor
Codes for speed variant (rpm)	
2	2-pole
4	4-pole

2. Product overview

Performance range, TP

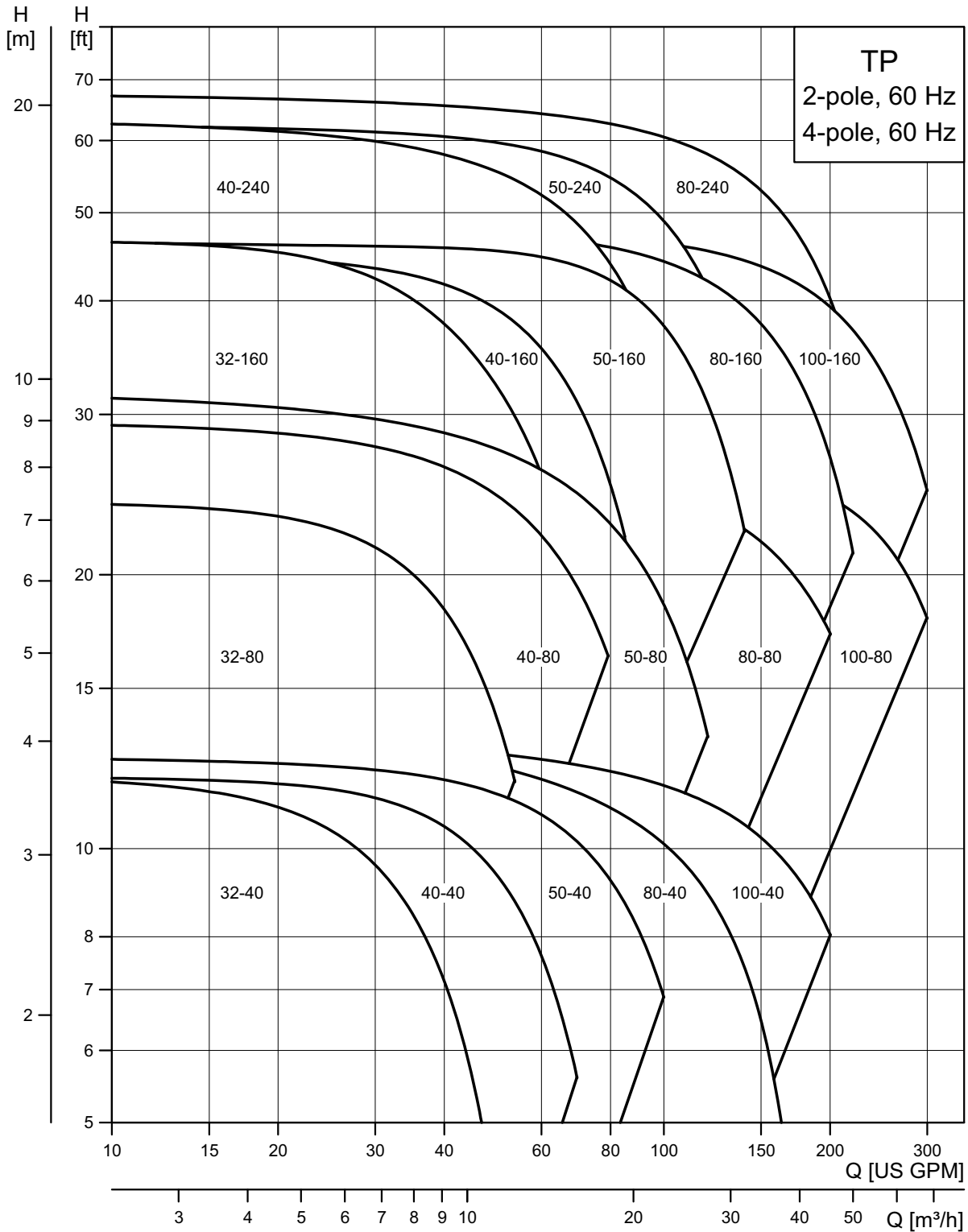

TM02 5104 4011

Fig. 2 Performance range, TP

Product range, TP

Pump type	Flow [gpm]	Head [ft]	Ph	Hp	Flange	Page
TP 32-40/4	8-50	3.5-12	1, 3	.33	1.25", 2 bolt, with .63" hole	16
TP 32-80/2	8-55	11-24	1, 3	.5	1.25", 2 bolt, with .63" hole	16
TP 32-160/2	8-70	18-47	1, 3	.75	1.5", 2 bolt, with .63" hole	16
TP 40-40/4	8-70	5-12	1, 3	.33	1.5", 2 bolt, with .63" hole	18
TP 40-80/2	8-80	16-29	1, 3	.75	1.5", 2 bolt, with .63" hole	18
TP 40-160/2	8-85	22-46	1, 3	.75	1.5", 2 bolt, with .63" hole	18
TP 40-240/2	8-100	33-63	1, 3	1.5	1.5", 2 bolt, with .63" hole	18
TP 50-40/4	8-100	7-13	1, 3	.33	2", 4 bolt with .56" hole	20
TP 50-80/2	8-120	14-32	1, 3	.75	2", 4 bolt with .56" hole	20
TP 50-160/2	8-140	22-47	1, 3	1.5	2", 4 bolt with .56" hole	20
TP 50-240/2	8-150	27-63	1, 3	2	2", 4 bolt with .56" hole	20
TP 80-40/4	12-170	4-14	1, 3	.5	3" ANSI 125lb RF	22
TP 80-80/4	12-200	17-28	1, 3	1.5	3" ANSI 125lb RF	22
TP 80-160/2	12-220	22-48	1, 3	3	3" ANSI 125lb RF	22
TP 80-240/2	12-240	26-67.5	1, 3	3	3" ANSI 125lb RF	22
TP 100-40/4	25-200	8-13.5	1, 3	1	4" ANSI 125lb RF	24
TP 100-80/4	25-300	18-28	1, 3	2	4" ANSI 125lb RF	24
TP 100-160/2	25-300	25-49	1, 3	3	4" ANSI 125lb RF	24

3. Construction

Construction, TP

The TP pump is a single-stage, in-line centrifugal pump with standard motor and mechanical shaft seal.

The pumps are of the top-pull-out design, i.e. pump head (motor, motor stool and impeller) can be removed without interfering with the pipework on either side of the pump housing. Consequently, service work on even the biggest pumps can be performed by a single person.

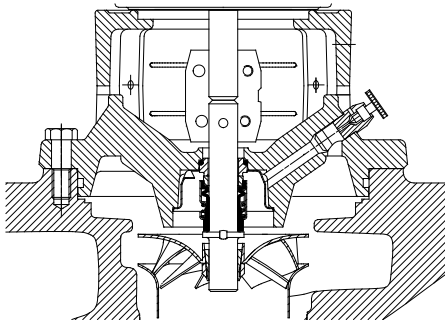

TM00 2265 4696

Fig. 3 Internal cross section, TP shaft and shaft seal

Material specification, TP

Pos.	Description	Materials	AISI, ASTM
2	Motor stool	Cast iron	
6	Pump housing	Cast iron	
7	Coupling guard	Stainless steel	304
8	Coupling	Sintered metal HPX PNC45	
17	Vent screw	Brass	
19	Pipe plug	Stainless steel	303
45	Neck ring	Stainless steel/ Teflon	
48	Split cone nut	Stainless steel	430F
49	Impeller	Stainless steel	304
49b	Split cone	Stainless steel	304
51	Shaft	Stainless steel	431
71	Distributing cup	Stainless steel	304
72a	O-ring/flat gasket	EPDM rubber	
105a	Shaft seal		

Sectional drawing, TP

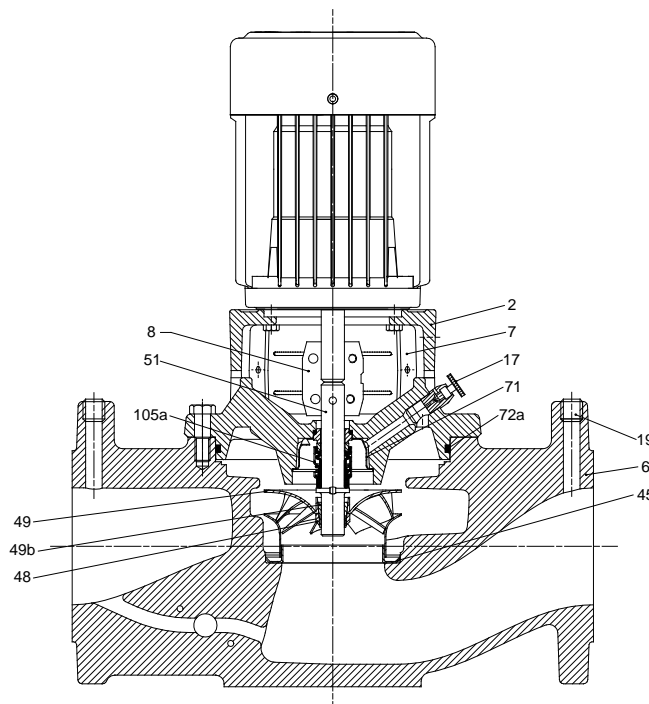

TM01 0175 0697

Fig. 4 Sectional drawing, TP

4. Operating conditions

Operating conditions

Relative humidity: Max. 95 %.

Max. working pressure: 145 psi (10 bar).

Liquid temperature

Liquid temperature:

–13 °F to +284 °F (–25 °C to +140 °C)

Please note that shaft seals operating close to their maximum temperature will require regular maintenance, i.e. replacement.

Pump type	Shaft seal	Temperature
TP	BUBE	32 °F to +284 °F (0 °C to +140 °C)
	AUUE	32 °F to +194 °F (0 °C to 90 °C)
	RUUE	–13 °F to +194 °F (–25 °C to +90 °C)

5. Installation

Mechanical installation

TP pumps can be installed in horizontal and vertical pipes.

Note: The motor must never point downwards.

The pumps must be installed in such a way that strain from the pipework is not transferred to the pump housing.

The pump may be suspended direct in the pipes, provided the pipework can support the pump. If not, the pump must be installed on a mounting bracket or base plate.

Space requirements

For inspection and motor/pump head removal a 12" (300 mm) clearance above the motor is required.

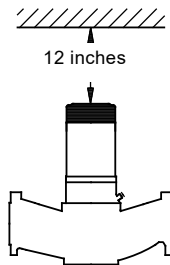

TM00 9242 3495

Fig. 5 Space requirements

Location of installation

The pump should be installed in a dry, well-ventilated area which is not subject to freezing or large variations in temperature.

The pump should never be mounted within six inches of any obstruction or hot surface.

Pumps to be installed outdoors or in a dusty environment should be ordered with a totally-enclosed-fan-cooled motor (TEFC) attached to prevent motor failure.

Position within piping system

Do not mount the pump at the highest or lowest point in the piping system.

If the pump is installed at the highest point in the piping system, it may experience reduced performance and increased noise due to air trapped in the pump.

If the pump is located at the lowest point in the piping system, the dirt and sediment in the system may collect inside the pump, causing premature wear to the shaft seal.

6. Product selection

Pumped liquids

Thin, clean, non-aggressive and non-explosive liquids, not containing solid particles or fibers that may mechanically or chemically attack the pump. Please see "List of pumped liquids" below.

Examples of liquids:

- central heating system water (we recommend that the water meets the requirements of accepted standards on water quality in heating systems)
- cooling liquids
- domestic hot water
- industrial liquids
- softened water.

If glycol or another antifreeze agent is added to the pumped liquid, the pump must have a shaft seal of the type RUUE.

The pumping of liquids with densities or kinematic viscosities higher than those of water can cause

- a considerable pressure drop
- a drop in the hydraulic performance
- a rise in the power consumption.

In these situations, equip the pump with an oversized motor. If in doubt, contact Grundfos.

If the water contains mineral oils or chemicals, or if other liquids than water are pumped, the O-rings should be chosen accordingly.

List of pumped liquids

Grundfos TP pumps are designed for circulation systems with constant flow, TPE pumps for systems with variable flow.

Thanks to their design, these pumps can be used in a wider liquid temperature range than pumps of the canned rotor type.

A number of typical liquids are listed on page [13](#).

Other pump versions may be used, but we consider the ones stated in the list to be the best choices.

The list is intended as a general guide only, and it cannot replace actual testing of the pumped liquids and pump materials under specific working conditions. If in doubt, contact Grundfos.

However, use the list with some caution as factors such as

- concentration of the pumped liquid
- liquid temperature or
- pressure

may affect the chemical resistance of a specific pump version.

Legend for notes in the list

A	May contain additives or impurities that may cause shaft seal problems.
B	The density and/or viscosity differ from those of water. Consider this when calculating motor and pump performance.
C	The liquid must be oxygen-free (anaerobic).
D	Risk of crystallization/precipitation in shaft seal.
E	Insoluble in water.
F	The shaft seal rubber parts must be replaced with FKM rubber.
G	Bronze housing/impeller required.
H	Risk of formation of ice on the standby pump.

Pumped liquids	Notes	Additional information	Shaft seal TP
Water			
Groundwater		<+194 °F (+90 °C)	AUUE
		>+194 °F (+90 °C)	BUBE
Boiler feed water		<+248 °F (+90 °C)	BUBE
District heating water		<+248 °F (+120 °C)	BUBE
Condensate		<+194 °F (+90 °C)	AUUE
		>+194 °F (+90 °C)	BUBE
Softened water	C	<+194 °F (+90 °C)	AUUE
		>+194 °F (+90 °C)	BUBE
Brackish water	G	pH>6.5, +40 °F (4.5 °C), 1000 ppm Cl ⁻	BUBE AUUE
Coolants			
Ethylene glycol	B, D, H	+122 °F (+50 °C), 50 %	AUUE RUUE
Glycerine (glycerol)	B, D, H	+122 °F (+50 °C), 50 %	AUUE RUUE
Potassium acetate	B, D, C, H	+122 °F (+50 °C), 50 %	AUUE RUUE
Potassium formate	B, D, C, H	+122 °F (+50 °C), 50 %	AUUE RUUE
Propylene glycol	B, D, H	+122 °F (+50 °C), 50 %	AUUE RUUE
Brine-sodium chloride	B, D, C, H	+41 °F (+5 °C), 30 %	AUUE RUUE
Synthetic oils			
Silicone oil	B, E		BUBE AUUE
Vegetable oils			
Corn oil	B, F, E		BUBV ³⁾ AUUV ³⁾
Olive oil	B, F, E	<+176 °F (80 °C)	BUBV ³⁾ AUUV ³⁾
Peanut oil	B, F, E		BUBV ³⁾ AUUV ³⁾
Grape seed oil	D, B, F, E		BUBV ³⁾ AUUV ³⁾
Soybean oil	B, F, E		BUBV ³⁾ AUUV ³⁾

Pumped liquids	Notes	Additional information	Shaft seal TP
Cleaning agents			
Soap (salts of fatty acids)	A, E, (F)	<+176 °F (+80 °C)	AUUE (AUUV) ³⁾
Alkaline degreasing agent	A, E, (F)	<+176 °F (+80 °C)	AUUE (AUUV) ³⁾
Oxidants			
Hydrogen peroxide		<+219 °F (+104 °C), <2 %	BUBE AUUE
Salts			
Ammonium bicarbonate	A	<+68 °F (+20 °C), <15 %	AUUE
Calcium acetate	A, B	<+68 °F (+20 °C), <30 %	AUUE
Potassium bicarbonate	A	<+68 °F (+20 °C), <20 %	AUUE
Potassium carbonate	A	<+68 °F (+20 °C), <20 %	AUUE
Potassium permanganate	A	<+68 °F (+20 °C), <10 %	AUUE
Potassium sulfate	A	<+68 °F (+20 °C), <20 %	AUUE
Sodium acetate	A	<+68 °F (+20 °C), <100 %	AUUE
Sodium bicarbonate	A	<+68 °F (+20 °C), <2 %	AUUE
Sodium carbonate	A	<+68 °F (+20 °C), <20 %	AUUE
Sodium nitrate	A	<+68 °F (+20 °C), <40 %	AUUE
Sodium nitrite	A	<+68 °F (+20 °C), <40 %	AUUE
Sodium phosphate (di)	A	<+212 °F (+100 °C), <30 %	AUUE
Sodium phosphate (tri)	A	<+194 °F (+90 °C), <20 %	AUUE
Sodium sulfate	A	<+68 °F (+20 °C), <20 %	AUUE
Sodium sulfite	A	<+68 °F (+20 °C), <1 %	AUUE
Alkalis			
Ammonium hydroxide		<+212 °F (+100 °C), <30 %	AUUE
Calcium hydroxide	A	<+212 °F (+100 °C), <10 %	AUUE
Potassium hydroxide	A	<+68 °F (+20 °C), <20 %	AUUE
Sodium hydroxide	A	<+104 °F (+40 °C), <20 %	AUUE

³⁾ The shaft seal is not standard, but available on request.

7. Curve charts/ technical data

Guidelines to the curve charts

The guidelines below apply to the curves shown on the following pages:

- The motors used for the measurements are standard motors (TEFC or MLE).
- Measurements have been made with airless water at a temperature of 68 °F (20 °C).
- The curves apply to a kinematic viscosity of $\nu = 1 \text{ mm}^2/\text{s}$ (1 cSt).
- Due to the risk of overheating, the pumps should not be used at a flow below the minimum flow rate.
- The QH curves apply to actual speed with the motor types mentioned at 60 Hz.

This page intentionally left blank.

TP 32-XX

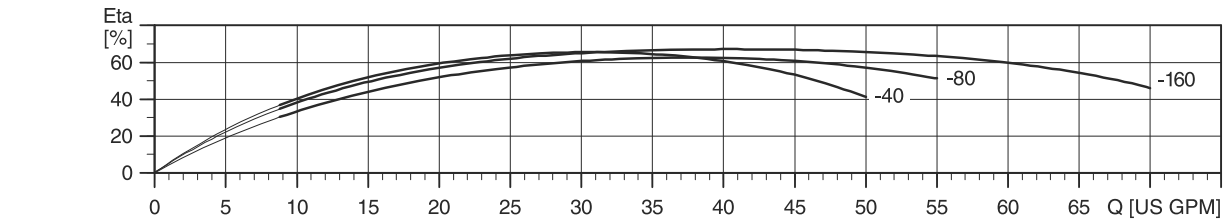
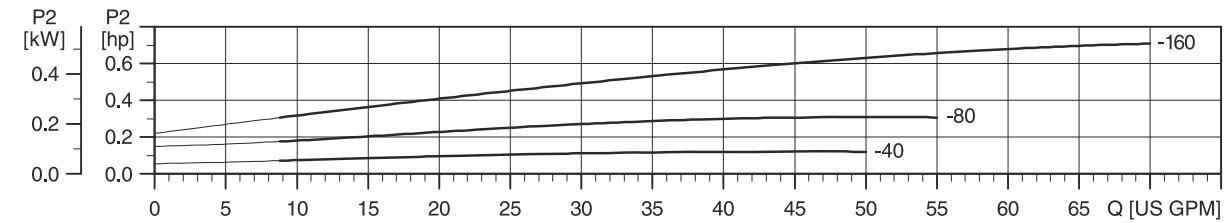
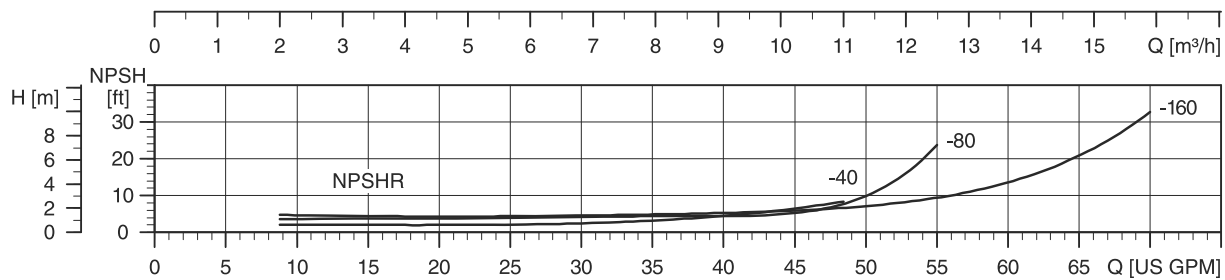
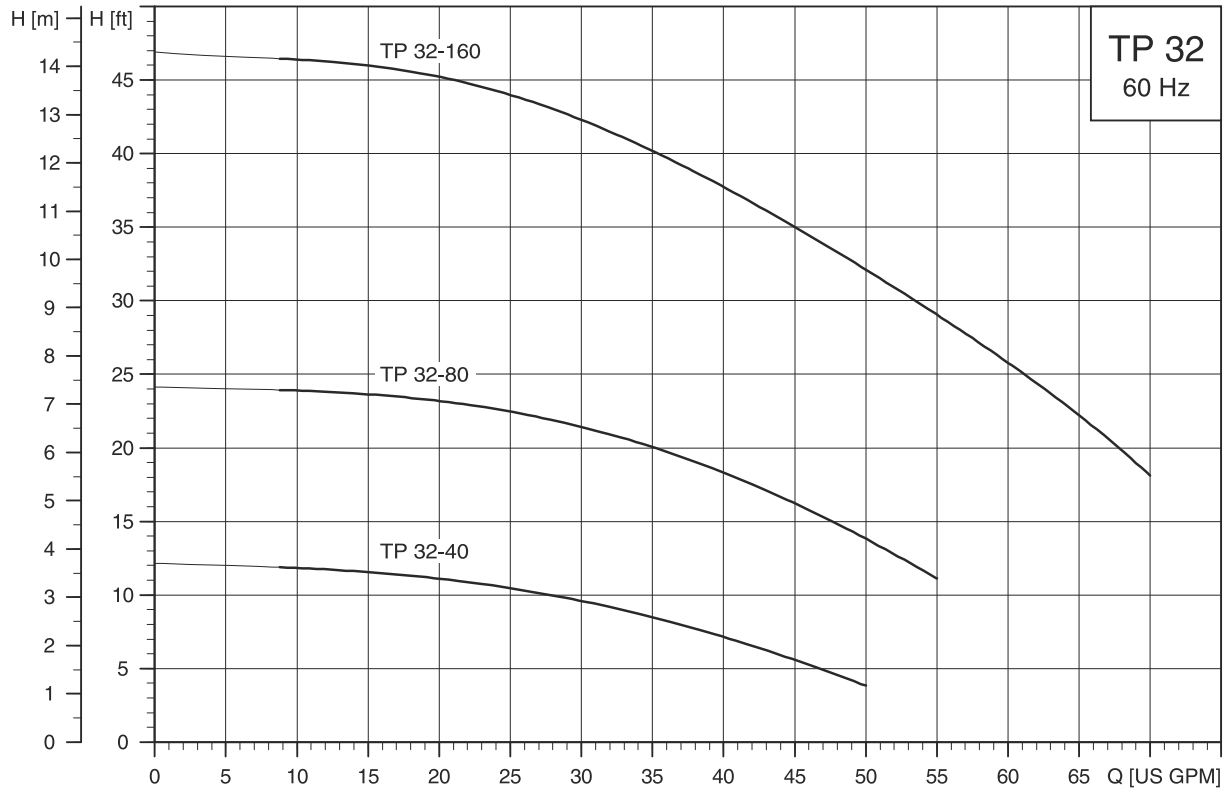

TM05 1936 3911

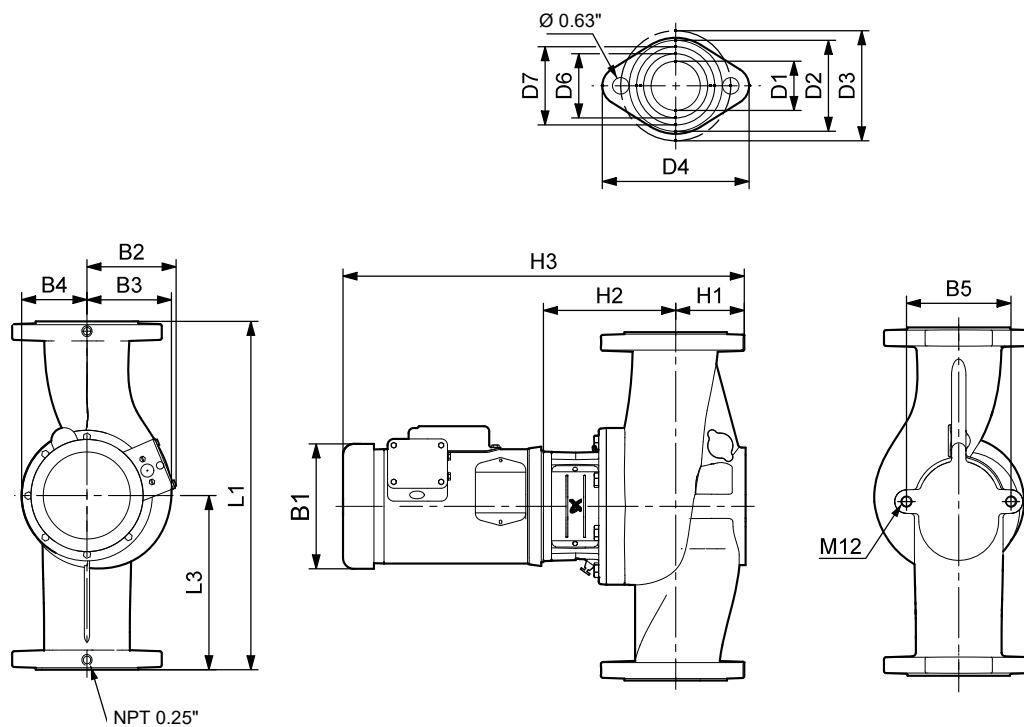

TM03 7757 4806

Dimensions and weights TP 32-XX

Pump type	Hp	Ph	Dimensions [inches (mm)]																Net weight [lbs]
			L1	L3	B1	B2	B3	B4	B5	H1	H2	H3	D1	D2	D3	D4	D6	D7	
TP 32-40/4	0.33	1	11 (279)	5.5 (140)	6.19 (157)	5.19 (132)	3 (76)	3 (76)	3.15 (80)	2.68 (68)	5.92 (150)	17.88 (454)	1.44 (37)	2.56 (65)	3.15 (80)	4.63 (118)	1.81 (46)	2.25 (57)	49
	0.33	3	11 (279)	5.5 (140)	6.19 (157)	5.19 (132)	3 (76)	3 (76)	3.15 (80)	2.68 (68)	5.92 (150)	17.88 (454)	1.44 (37)	2.56 (65)	3.15 (80)	4.63 (118)	1.81 (46)	2.25 (57)	48
TP 32-80/2	0.5	1	11 (279)	5.5 (140)	6.19 (157)	5.19 (132)	3 (76)	3 (76)	3.15 (80)	2.68 (68)	5.80 (147)	18.39 (467)	1.44 (37)	2.56 (65)	3.15 (80)	4.63 (118)	1.81 (46)	2.25 (57)	52
	0.5	3	11 (279)	5.5 (140)	5.55 (141)	4.57 (116)	3 (76)	3 (76)	3.15 (80)	2.68 (68)	5.80 (147)	15.92 (404)	1.44 (37)	2.56 (65)	3.15 (80)	4.63 (118)	1.81 (46)	2.25 (57)	51
TP 32-160/2	0.75	1	13.5 (343)	6.75 (171)	6.19 (157)	5.19 (132)	3 (76)	3 (76)	3.15 (80)	2.68 (68)	5.84 (148)	17.81 (452)	1.69 (43)	2.88 (73)	3.43 (87)	5 (127)	2.05 (52)	2.54 (67)	54
	0.75	3	13.5 (343)	6.75 (171)	5.55 (141)	4.57 (116)	3 (76)	3 (76)	3.15 (80)	2.68 (68)	5.84 (148)	15.96 (405)	1.69 (43)	2.88 (73)	3.43 (87)	5 (127)	2.05 (52)	2.54 (67)	53

Note: For information about motor data, see page 27.

Technical data

Flow range:	8-70 U.S. gpm
Head range:	3.5-47 ft
Maximum working pressure:	145 psi (10 bar)
Temperature range:	5 °F (-15 °C) to 284 °F (140 °C)
Max ambient air temperature:	104 °F (40 °C)
Motors:	TEFC-Standard, ODP-Optional
Flanges:	1 1/4" (TP32-40, TP32-80) and 1 1/2" (TP32-160), 2 bolt with (2) .63" dia. holes

TP 40-XX

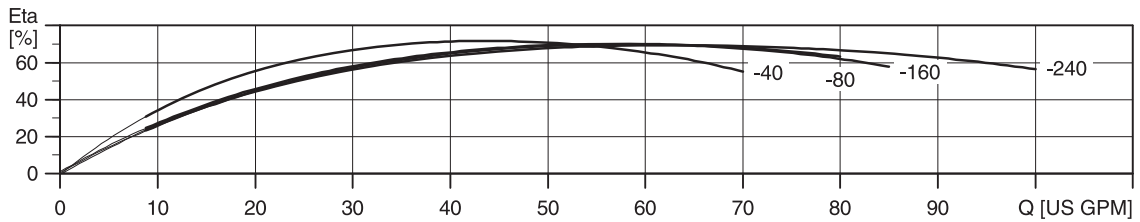
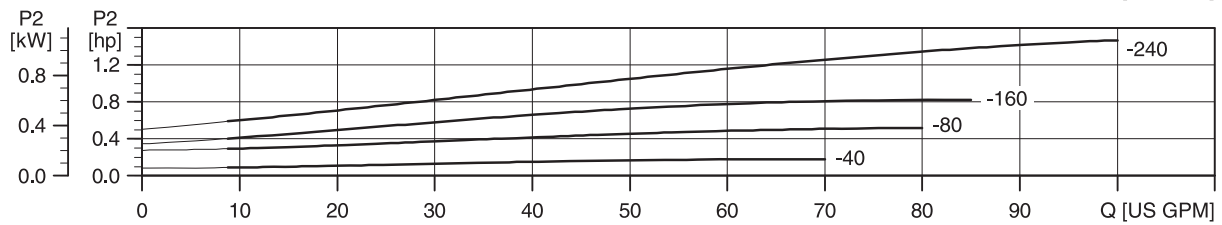
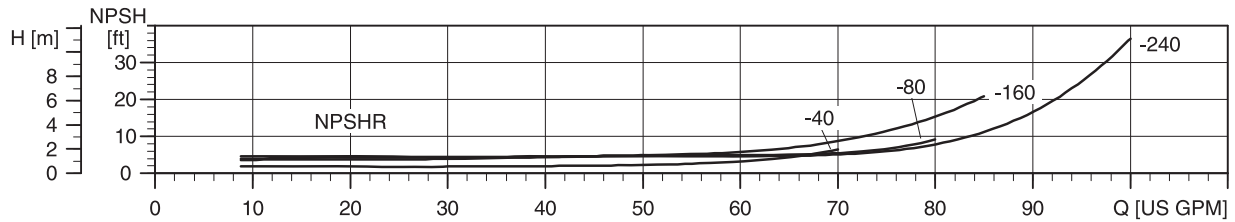
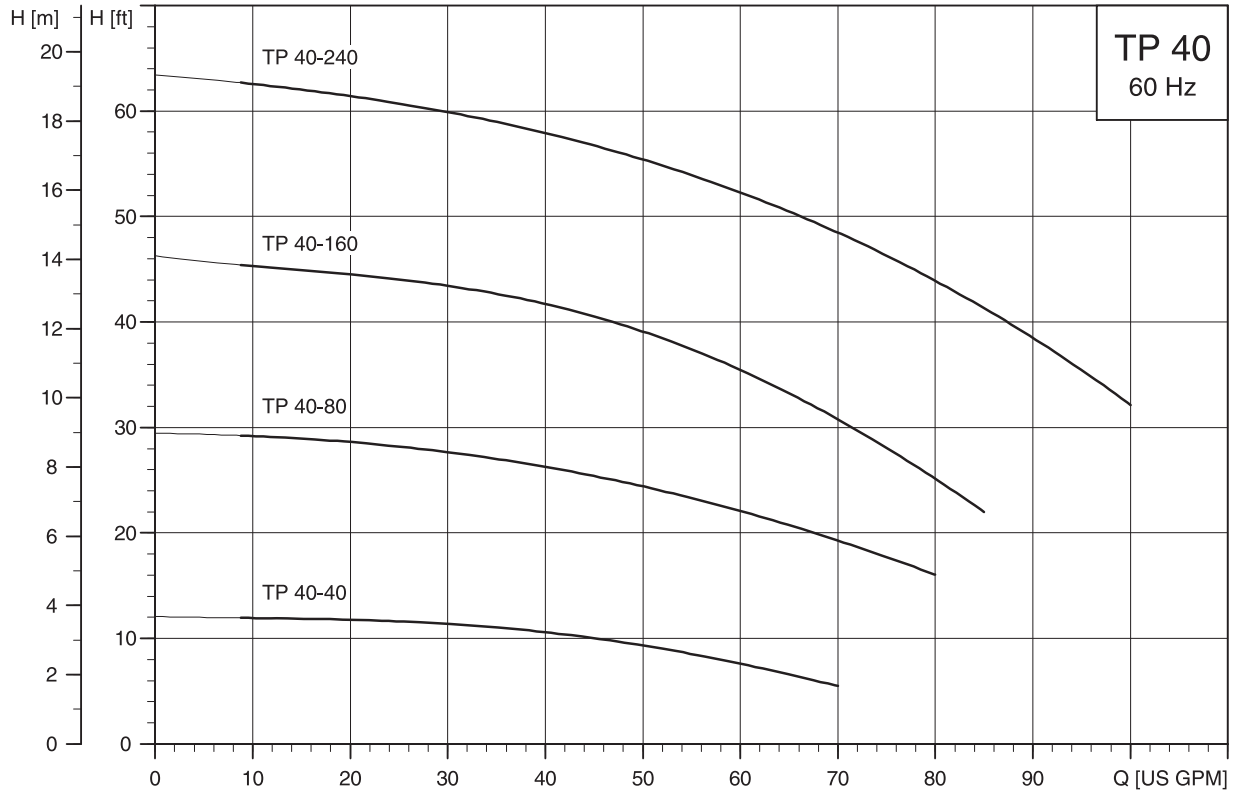

TK00 9226 1897

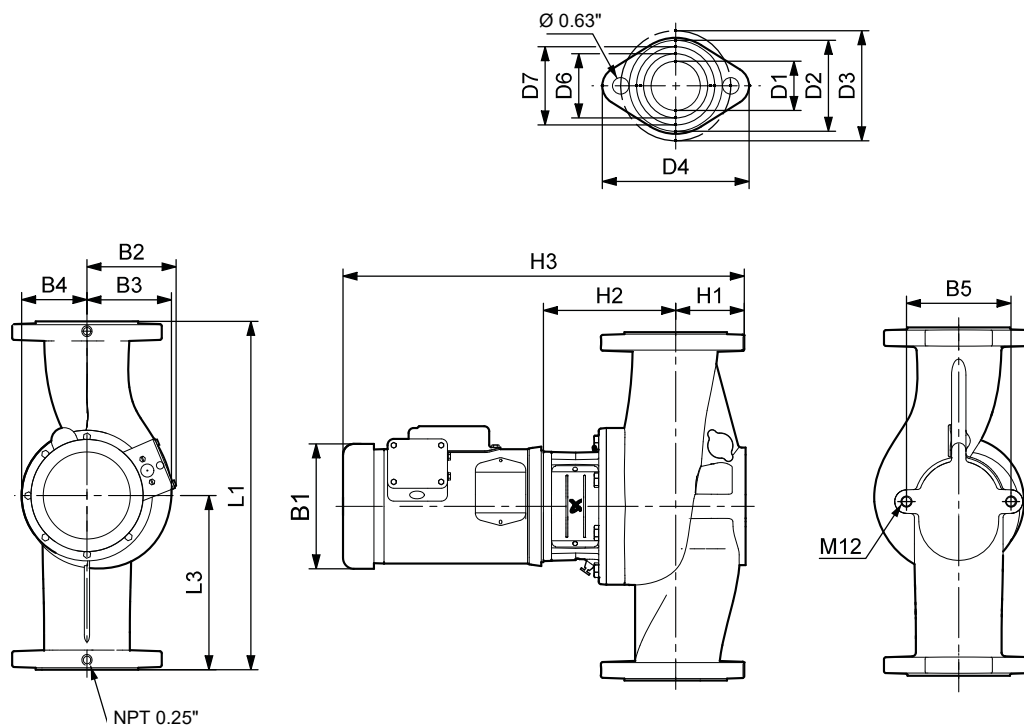

TM03 7757 4806

Dimensions and weights TP 40-XX

Pump type	Hp	Ph	Dimensions [inches (mm)]															Net weight [lbs]	
			L1	L3	B1	B2	B3	B4	B5	H1	H2	H3	D1	D2	D3	D4	D6		D7
TP 40-40/4	0.33	1	13.5 (343)	6.75 (171)	6.19 (157)	5.19 (132)	3.38 (86)	3 (76)	4.72 (120)	2.68 (68)	6.08 (154)	18.05 (458)	1.69 (43)	2.88 (73)	3.43 (87)	5 (127)	2.05 (52)	2.54 (65)	54
	0.33	3	13.5 (343)	6.75 (171)	6.19 (157)	5.19 (132)	3.38 (86)	3 (76)	4.72 (120)	2.68 (68)	6.08 (154)	18.05 (458)	1.69 (43)	2.88 (73)	3.43 (87)	5 (127)	2.05 (52)	2.54 (65)	53
TP 40-80/2	0.75	1	13.5 (343)	6.75 (171)	6.19 (157)	5.19 (132)	3 (76)	3 (76)	3.15 (80)	2.68 (68)	6.04 (153)	18.01 (457)	1.69 (43)	2.88 (73)	3.43 (87)	5 (127)	2.05 (52)	2.54 (65)	55
	0.75	3	13.5 (343)	6.75 (171)	5.55 (141)	4.57 (116)	3 (76)	3 (76)	3.15 (80)	2.68 (68)	6.04 (153)	16.16 (410)	1.69 (43)	2.88 (73)	3.43 (87)	5 (127)	2.05 (52)	2.54 (65)	54
TP 40-160/2	0.75	1	11.5 (292)	5.75 (146)	6.19 (157)	5.19 (132)	4 (102)	4 (102)	3.15 (80)	2.68 (68)	5.79 (147)	17.75 (451)	1.69 (43)	2.88 (73)	3.43 (87)	5 (127)	2.05 (52)	2.54 (65)	54
	0.75	3	11.5 (292)	5.75 (146)	5.55 (141)	4.57 (116)	4 (102)	4 (102)	3.15 (80)	2.68 (68)	5.79 (147)	15.90 (404)	1.69 (43)	2.88 (73)	3.43 (87)	5 (127)	2.05 (52)	2.54 (65)	53
TP 40-240/2	1.5	1	13.5 (343)	6.75 (171)	7.19 (183)	5.74 (146)	4 (102)	4 (102)	3.15 (80)	2.68 (68)	6.17 (157)	20.52 (521)	1.69 (43)	2.88 (73)	3.43 (87)	5 (127)	2.05 (52)	2.54 (65)	58
	1.5	3	13.5 (343)	6.75 (171)	5.55 (141)	4.57 (116)	4 (102)	4 (102)	3.15 (80)	2.68 (68)	6.17 (157)	17.46 (443)	1.69 (43)	2.88 (73)	3.43 (87)	5 (127)	2.05 (52)	2.54 (65)	57

Note: For information about motor data, see page 27.

Technical data

Flow range:	8-100 U.S. gpm
Head range:	5-63 ft
Maximum working pressure:	145 psi (10 bar)
Temperature range:	5 °F (-15 °C) to 284 °F (140 °C)
Max ambient air temperature:	104 °F (40 °C)
Motors:	TEFC-Standard, ODP-Optional
Flanges:	1 1/2" 2 bolt with (2) .63" dia. holes

TP 50-XX

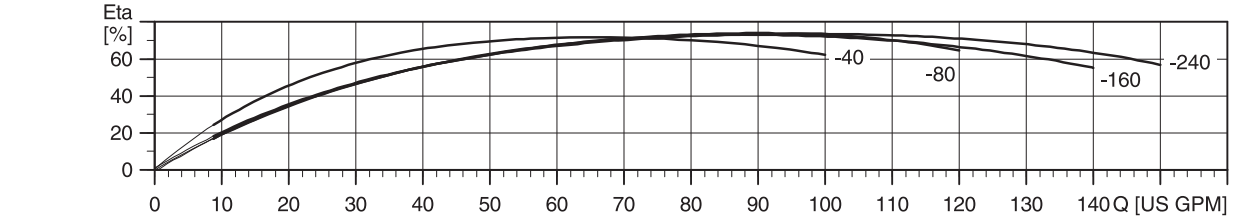
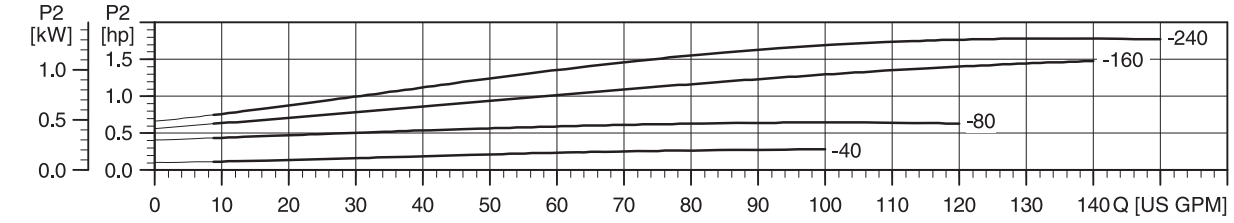
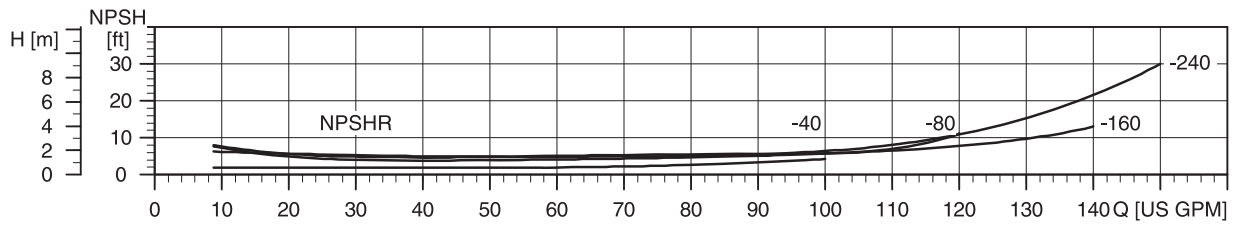
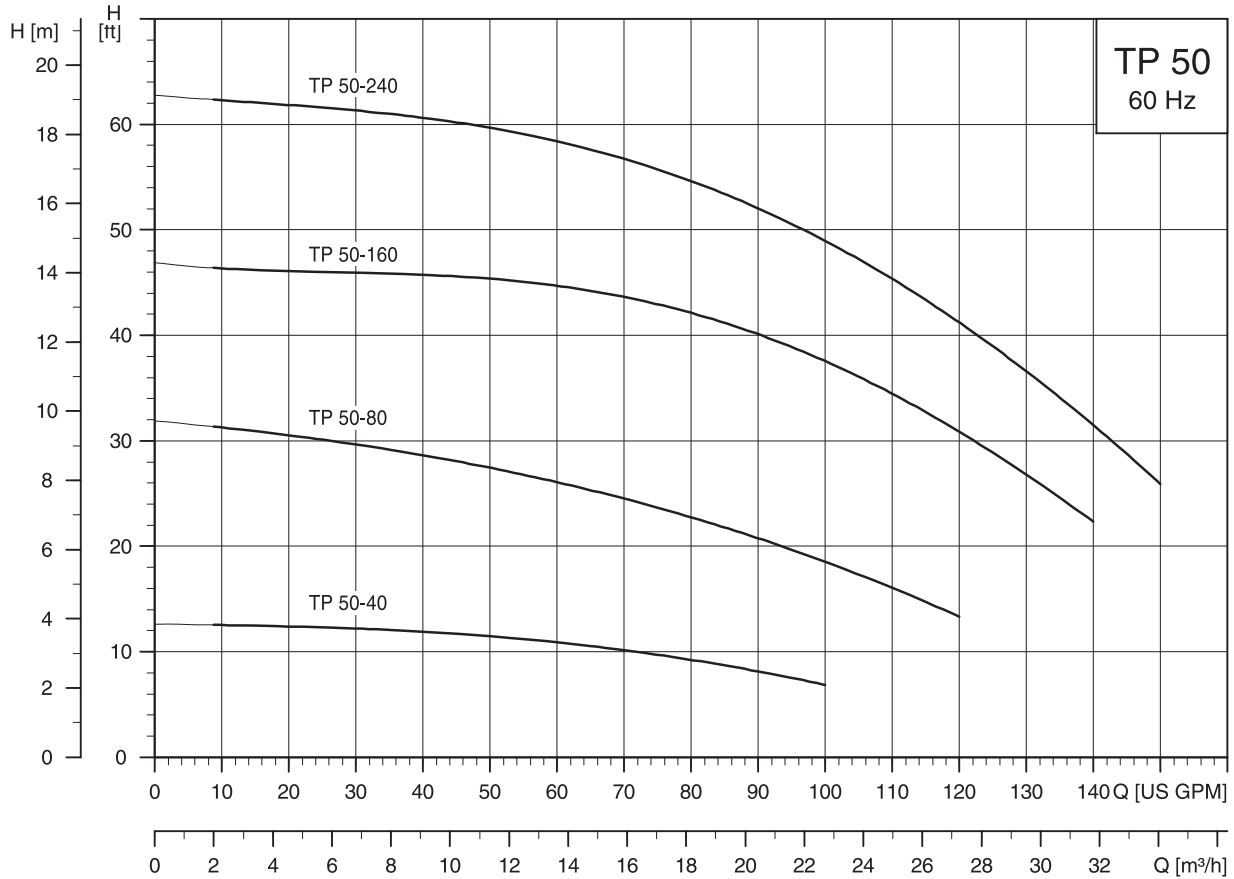

TK00 9227 1897

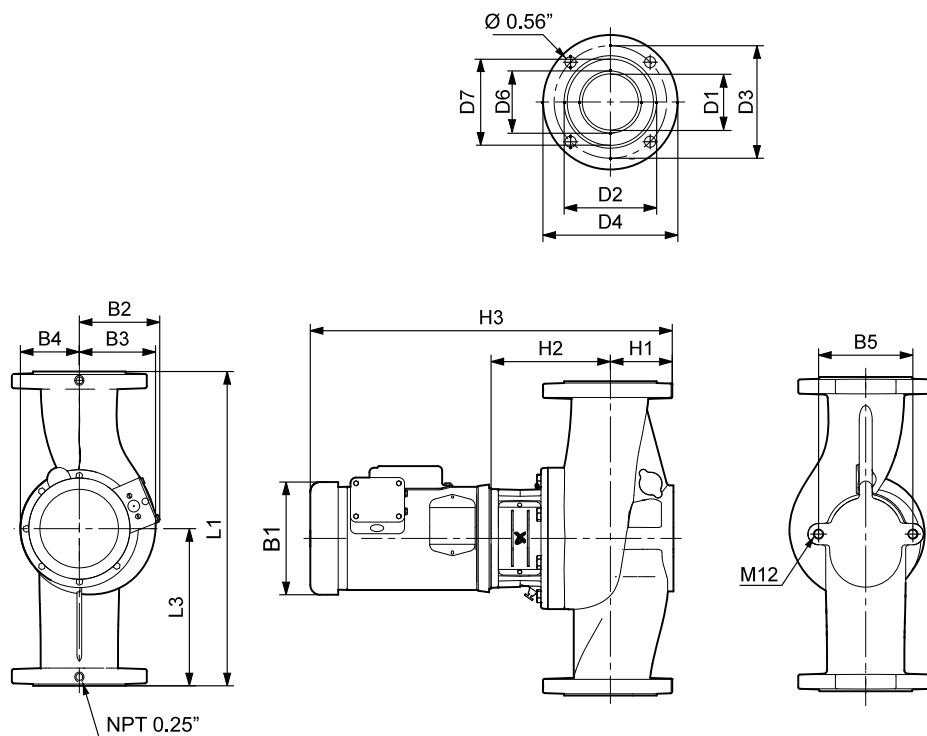

TM05 1954 4011

Dimensions and weights TP 50-XX

Pump type	Hp	Ph	Dimensions [inches (mm)]																Net weight [lbs]
			L1	L3	B1	B2	B3	B4	B5	H1	H2	H3	D1	D2	D3	D4	D6	D7	
TP 50-40/4	0.33	1	14 (356)	7 (178)	6.19 (157)	5.19 (132)	3.56 (90)	3 (76)	4.72 (120)	3.23 (82)	6.20 (157)	18.72 (475)	2.09 (53)	3.39 (86)	4.06 (103)	5.25 (133)	2.5 (64)	3.06 (78)	54
	0.33	3	14 (356)	7 (178)	6.19 (157)	5.19 (132)	3.56 (90)	3 (76)	4.72 (120)	3.23 (82)	6.20 (157)	18.72 (475)	2.09 (53)	3.39 (86)	4.06 (103)	5.25 (133)	2.5 (64)	3.06 (78)	53
TP 50-80/2	0.75	1	11.5 (292)	5.75 (146)	6.19 (157)	5.19 (132)	3.75 (95)	3 (76)	4.72 (120)	2.95 (75)	6.26 (159)	18.50 (470)	2.09 (53)	3.46 (88)	4.06 (103)	5.25 (133)	2.5 (64)	3.06 (78)	58
	0.75	3	11.5 (292)	5.75 (146)	5.55 (141)	4.57 (116)	3.75 (95)	3 (76)	4.72 (120)	2.95 (75)	6.26 (159)	16.65 (423)	2.09 (53)	3.46 (88)	4.06 (103)	5.25 (133)	2.5 (64)	3.06 (78)	57
TP 50-160/2	1.5	1	14 (356)	7 (178)	7.19 (183)	5.74 (146)	4 (102)	4 (102)	4.72 (120)	2.95 (75)	5.83 (148)	20.46 (520)	2.09 (53)	3.46 (88)	4.06 (103)	5.25 (133)	2.5 (64)	3.06 (78)	67
	1.5	3	14 (356)	7 (178)	5.55 (141)	4.57 (116)	4 (102)	4 (102)	4.72 (120)	2.95 (75)	5.83 (148)	17.40 (442)	2.09 (53)	3.46 (88)	4.06 (103)	5.25 (133)	2.5 (64)	3.06 (78)	66
TP 50-240/2	2	1	14 (356)	7 (178)	7.19 (183)	5.74 (146)	4 (102)	4 (102)	4.72 (120)	2.95 (75)	5.83 (148)	21.34 (542)	2.09 (53)	3.46 (88)	4.06 (103)	5.25 (133)	2.5 (64)	3.06 (78)	71
	2	3	14 (356)	7 (178)	7.01 (178)	4.33 (110)	4 (102)	4 (102)	4.72 (120)	2.95 (75)	5.83 (148)	20.00 (508)	2.09 (53)	3.46 (88)	4.06 (103)	5.25 (133)	2.5 (64)	3.06 (78)	70

Note: For information about motor data, see page 27.

Technical data

Flow range:	8-150 U.S. gpm
Head range:	7-63 ft
Maximum working pressure:	145 psi (10 bar)
Temperature range:	5 °F (-15 °C) to 284 °F (140 °C)
Max ambient air temperature:	104 °F (40 °C)
Motors:	TEFC-Standard, ODP-Optional
Flanges:	2" 4 bolt with (4) .56" dia. holes

TP 80-XX

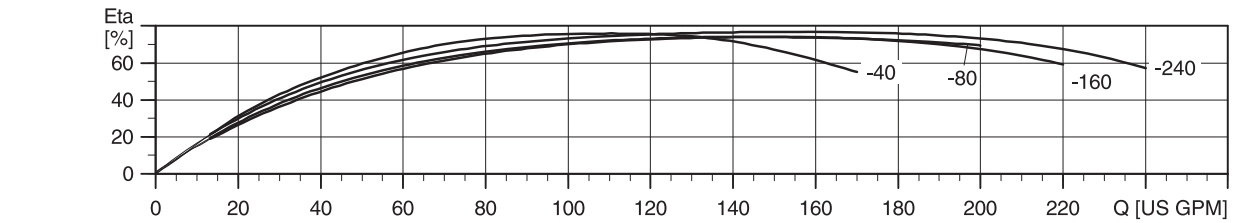
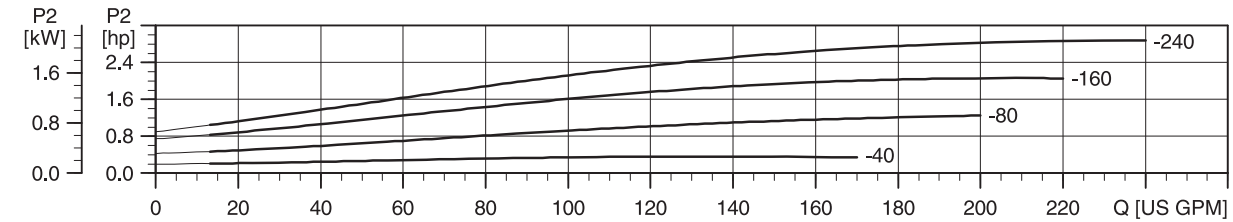
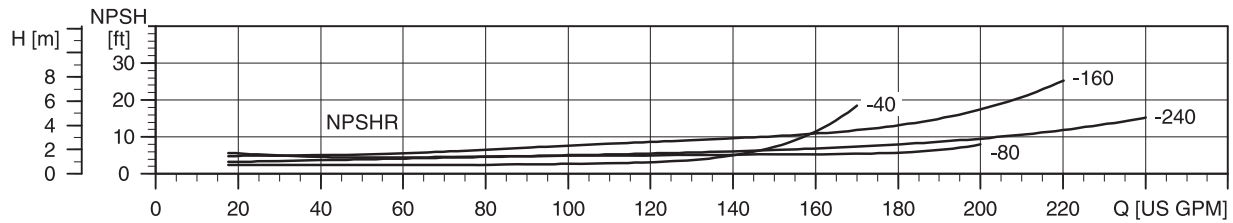
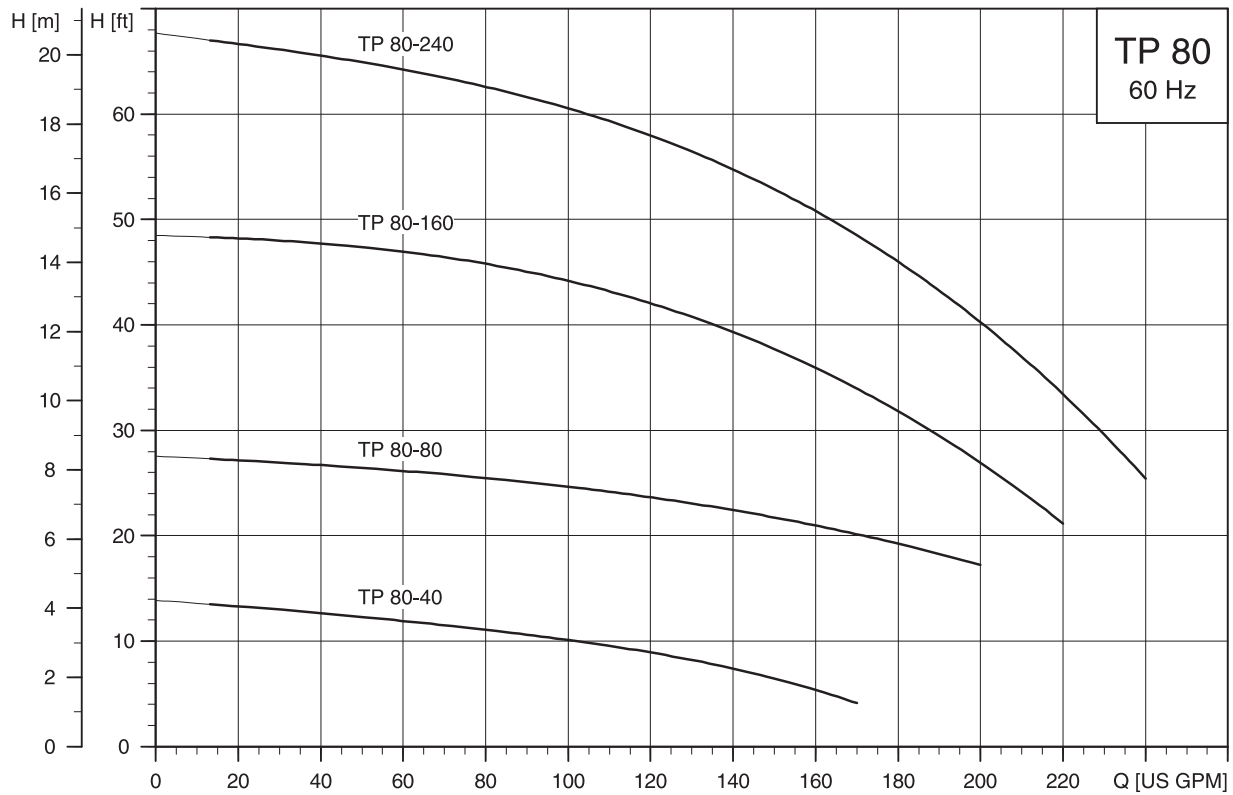

TK00 9228 1097

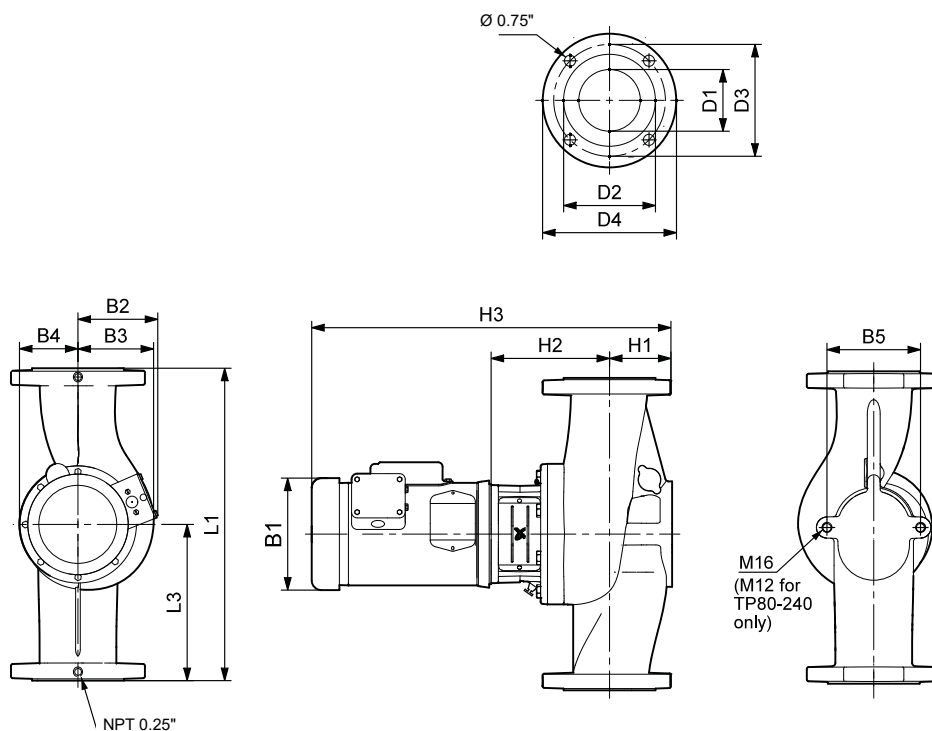

TMD 7769 4806

Dimensions and weights TP 80-XX

Pump type	Hp	Ph	Dimensions [inches (mm)]																	Net weight [lbs]
			L1	L3	B1	B2	B3	B4	B5	H1	H2	H3	D1	D2	D3	D4	D6	D7		
TP 80-40/4	0.5	1	19 (483)	9.5 (241)	6.19 (157)	5.19 (132)	5	4	6.3 (160)	3.82 (97)	6.33 (161)	20.06 (510)	3.19 (81)	5	6	7.5 (191)	-	-	121	
	0.5	3	19 (483)	9.5 (241)	6.19 (157)	5.19 (132)	5	4	6.3 (160)	3.82 (97)	6.33 (161)	19.44 (494)	3.19 (81)	5	6	7.5 (191)	-	-	116	
TP 80-80/4	1.5	1	19 (483)	9.5 (241)	7.19 (183)	5.74 (146)	5	4	6.3 (160)	3.82 (97)	6.33 (161)	22.21 (564)	3.19 (81)	5	6	7.5 (191)	-	-	121	
	1.5	3	19 (483)	9.5 (241)	7.19 (183)	5.74 (146)	5	4	6.3 (160)	3.82 (97)	6.33 (161)	21.32 (543)	3.19 (81)	5	6	7.5 (191)	-	-	120	
TP 80-160/2	3	1	19 (483)	9.5 (241)	8.6 (218)	6.87 (175)	4	4	6.3 (160)	3.82 (97)	7.04 (179)	25.26 (642)	3.19 (81)	5	6	7.5 (191)	-	-	145	
	3	3	19 (483)	9.5 (241)	7.01 (178)	4.33 (110)	4	4	6.3 (160)	3.82 (97)	7.04 (179)	24.09 (612)	3.19 (81)	5	6	7.5 (191)	-	-	152	
TP 80-240/2	3	1	19 (483)	9.5 (241)	8.6 (218)	6.87 (175)	4	4	4.72 (120)	3.82 (97)	6.84 (174)	25.06 (637)	3.19 (81)	5	6	7.5 (191)	-	-	144	
	3	3	19 (483)	9.5 (241)	7.01 (178)	4.33 (110)	4	4	4.72 (120)	3.82 (97)	6.84 (174)	23.89 (607)	3.19 (81)	5	6	7.5 (191)	-	-	143	

Note: For information about motor data, see page 27.

Technical data

Flow range:	12-240 U.S. gpm
Head range:	4-67 ft
Maximum working pressure:	145 psi (10 bar)
Temperature range:	5 °F (-15 °C) to 284 °F (140 °C)
Max ambient air temperature:	104 °F (40 °C)
Motors:	TEFC-Standard, ODP-Optional
Flanges:	3" ANSI 125 lb., R.F.

TP 100-XX

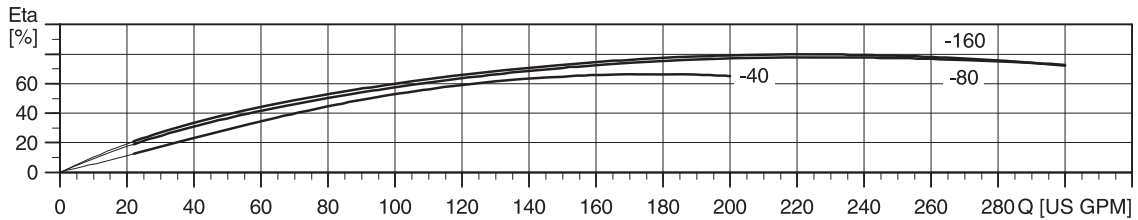
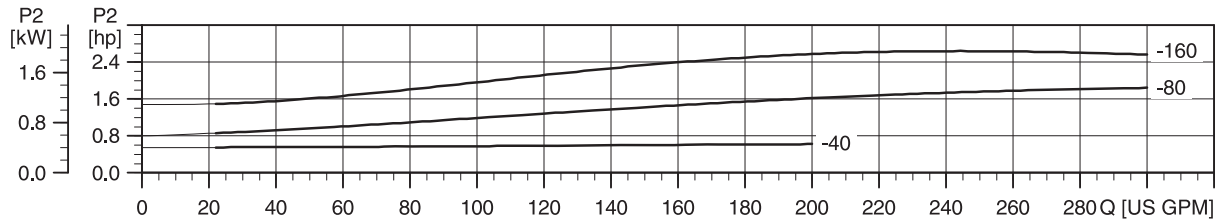
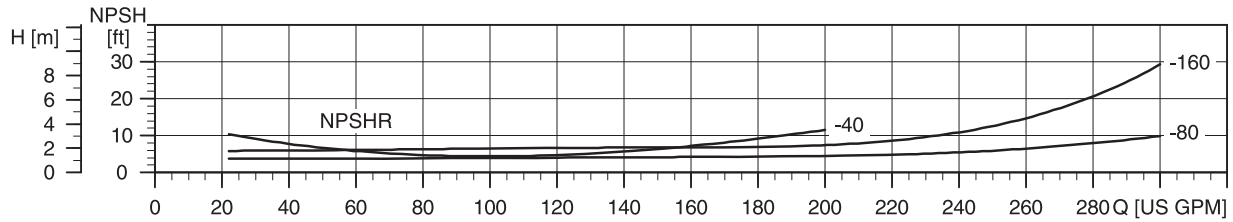
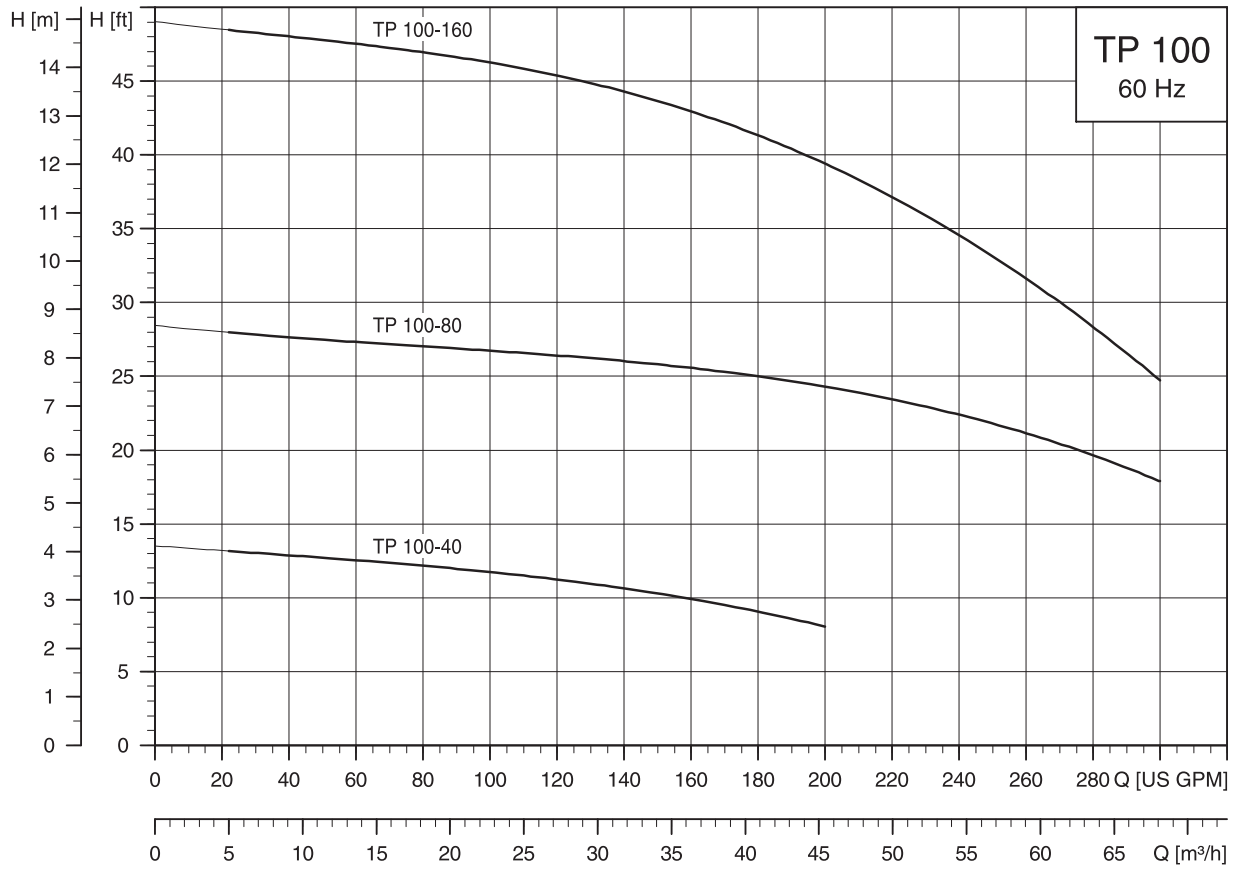

TK00 9229 1097

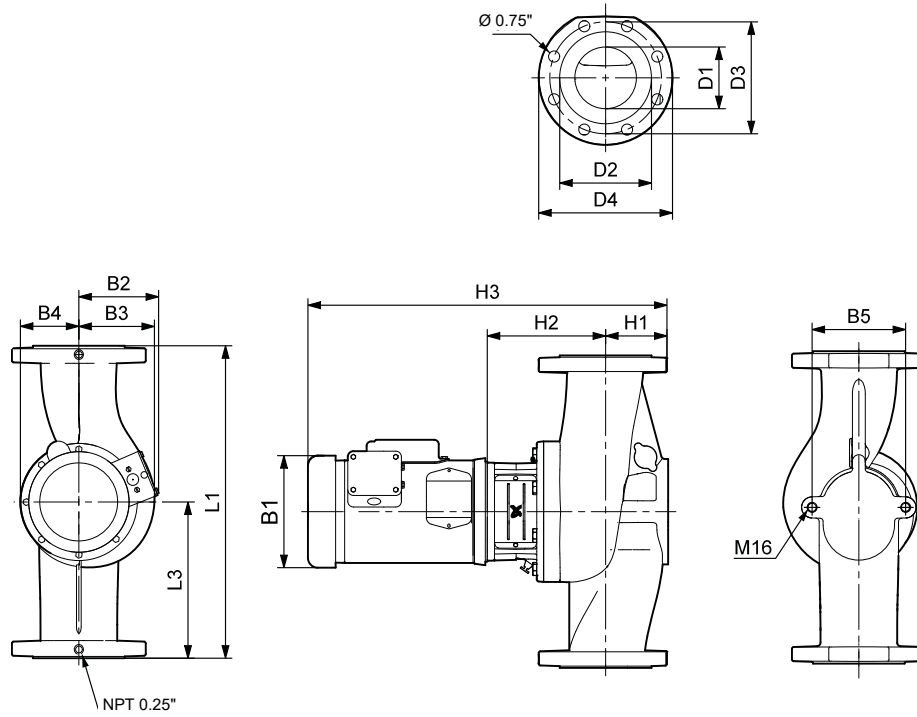

TM03 7755 4806

Dimensions and weights TP 100-XX

Pump type	Hp	Ph	Dimensions [inches (mm)]														Net weight [lbs]		
			L1	L3	B1	B2	B3	B4	B5	H1	H2	H3	D1	D2	D3	D4		D6	D7
TP 100-40/4	1	1	21 (533)	10.5 (267)	7.19 (183)	5.74 (146)	5.13 (130)	4 (102)	6.3 (160)	4.21 (107)	7.41 (188)	22.81 (579)	4.13 (105)	6.18 (157)	7.5 (191)	9 (229)	-	-	139
	1	3	21 (533)	10.5 (267)	7.19 (183)	5.74 (146)	5.13 (130)	4 (102)	6.3 (160)	4.21 (107)	7.41 (188)	21.79 (553)	4.13 (105)	6.18 (157)	7.5 (191)	9 (229)	-	-	150
TP 100-80/4	2	1	21 (533)	10.5 (267)	7.19 (183)	5.74 (146)	5.31 (135)	4 (102)	6.3 (160)	4.80 (122)	6.57 (167)	23.43 (595)	4.13 (105)	6.18 (157)	7.5 (191)	9 (229)	-	-	149
	2	3	21 (533)	10.5 (267)	7.19 (183)	5.74 (146)	5.31 (135)	4 (102)	6.3 (160)	4.80 (122)	6.57 (167)	22.54 (573)	4.13 (105)	6.18 (157)	7.5 (191)	9 (229)	-	-	156
TP 100-160/2	3	1	21 (533)	10.5 (267)	8.6 (218)	6.87 (175)	4.94 (126)	4 (102)	6.3 (160)	4.21 (107)	7.22 (183)	25.83 (656)	4.13 (105)	6.18 (157)	7.5 (191)	9 (229)	-	-	163
	3	3	21 (533)	10.5 (267)	7.01 (178)	4.33 (110)	4.94 (126)	4 (102)	6.3 (160)	4.21 (107)	7.22 (183)	24.66 (626)	4.13 (105)	6.18 (157)	7.5 (191)	9 (229)	-	-	162

Note: For information about motor data, see page 27.

Technical data

Flow range:	25-300 U.S. gpm
Head range:	8-49 ft
Maximum working pressure:	145 psi (10 bar)
Temperature range:	5 °F (-15 °C) to 284 °F (140 °C)
Max ambient air temperature:	104 °F (40 °C)
Motors:	TEFC-Standard, ODP-Optional
Flanges:	4" ANSI 125 lb., R.F.

8. Accessories

Packaged flange sets^{*}

For use w/models	Product numbers		Description
Accessories and spare parts			
UPS/TP 32-40	519603	1.25"	Threaded, cast iron
	96409356		Threaded, bronze
UPS/TP 32-80	519603	1.25"	Threaded, cast iron
	96409356		Threaded, bronze
UPS/TP 32-160UPS/TP40-All	539605	1.5"	Threaded, cast iron
	539615		Threaded, bronze
UPS/TP 50 (All models)	96409354	2"	Threaded, cast iron
	96409355		Threaded, bronze
UPS/TP 80 (All models)	569601	3"	Threaded, ANSI 125# Cast iron
	569611		Threaded, ANSI 125# bronze
UPS/TP 100 (All models)	579801	4"	Threaded, ANSI 125# Cast iron
	96409355		Threaded, ANSI 125# bronze
Flange gaskets			
For use w/these flange sets	Product numbers		Description
1.25" Threaded	510179		Single gasket for 1.25" flange
1.25" Threaded	530244		Single gasket for 1.5" flange
2" Threaded	96409353		Single gasket for 2" flange
3" Threaded 125#	560185		Single gasket for 3" flange
4" Threaded 125#	570008		Single gasket for 4" flange

* Flange set includes two (2) flanges, two (2) gaskets, and either four (4) or eight (8) nuts and bolts as needed.

TP optional shaft seal kits

TP - Optional shaft seal kits			
For use with these models	Type, seal faces, elastomers	Designation	Product number
All TP	O-ring type, tungsten carbide/tungsten carbide, EPDM	AUUE	96409266
For use with glycol/water mixtures			
For use with these models	Type, seal faces, elastomers	Designation	Product number
All TP	Reduced face O-ring type, tungsten carbide/tungsten carbide, EPDM and FKM	RUUE/V	985844

9. Motors (electrical data)

TP TEFC motors

/2 Pole										
Hp	Ph	S.F.	Voltage [A]	Mtr. Eff. [%]	Insul. class	KVA code	Full load current [A]	Service factor current [A]	Start current [A]	Mtr. Type
.5	1	1.6	115/208-230	62	B	K	7.4/5.2-3.7	9.8/5.2-4.9	39.0/21.6-19.5	Baldor
	3	1.25	208-230/460	79	F	K	1.64-1.55/0.78	2.0-1.9/0.95	9.7-10.1/5.1	Grundfos
.75	1	1.25	115/208-230	66	B	K	9.6/5.3-4.8	11.4/6.0-5.7	56/31.0-28	Baldor
	3	1.25	208-230/460	80	F	K	2.4-2.3/1.2	2.9-2.75/1.4	14.2-15/7.8	Grundfos
1.5	1	1.3	115/208-230	71	B	K	17/9.5-8.6	20.4/11.3-10.2	106/58.6-53	Baldor
	3	1.15	208-230/460	84	F	M	4.7-4.6/2.3	5.2-5.1/2.55	33.8-36.8/18.4	Grundfos
2	1	1.15	115/208-230	74	F	K	23/12.7-11.5	25.4/12.7-12.7	156/86.2-78	Baldor
	3	1.15	208-230/460	85	F	G	5.7-5.4/2.7	6.55-6.1/3.05	46.2-48.6/24.3	Grundfos
3	1	1.15	115/208-230	75	F	H	29/16-14.5	31.8/18-15.9	170/94-85	Baldor
	3	1.15	208-230/460	86	F	K	8.4-7.7/3.9	9.5-8.6/4.3	60.5-63.8/31.9	Grundfos
/4 Pole										
Hp	Ph	S.F.	Voltage [A]	Mtr. Eff. [%]	Insul. class	KVA code	Full load current [A]	Service factor current [A]	Start current [A]	Mtr. Type
.33	1	1.35	115/208-230	60	B	L	6/3.6-3	6.8/4.1-3.4	26/14.4-13	Baldor
	3	1.35	208-230/460	68	B	M	1.9-1.6/0.8	2-1.8/1.9	9.7-8.8/4.4	Baldor
.5	1	1.25	115/208-230	68	B	J	7.4/3.9-3.7	8.2/4.3-4.1	33/18.2-16.5	Baldor
	3	1.25	208-230/460	74	B	L	2.5-2/1	2.9-2.4/1.2	14.4-13/6.5	Baldor
1	1	1.15	115/208-230	67	B	K	13.0/7.6-6.5	14.2/7.1	74/40.9-37	Baldor
	3	1.15	208-230/460	77	B	J	3.4-3.2/1.6	3.6-3.4/1.6	25.4-23/11.5	Baldor
1.5	1	1.15	115/208-230	72	B	L	16/8.2-8.0	18.5/9.4-9.2	228/126.1-114	Baldor
	3	1.15	208-230/460	79	B	K	5.1-4.8/2.4	5.4-5.1/2.55	42.1-38/19	Baldor
2	1	1.15	115/230	78	F	J	17.2/8.6	19.2/9.6	234/117	Baldor
	3	1.15	208-230/460	83	B	K	6.4-6.2/3.1	7-6.8/3.4	52.6-47.6/23.8	Baldor

This page intentionally left blank.

11. Grundfos Product Center

Online search and sizing tool to help you make the right choice.

<http://product-selection.grundfos.com>



This drop-down menu enables you to set the search function to "Products" or "Literature".

"SIZING" enables you to size a pump based on entered data and selection choices.

"REPLACEMENT" enables you to find a replacement product. Search results will include information on the following:

- the lowest purchase price
- the lowest energy consumption
- the lowest total life cycle cost.

The screenshot shows the Grundfos Product Center website. At the top, there is a navigation bar with 'HOME', 'FIND PRODUCT', 'COMPARE', 'YOUR PROJECTS', 'SAVED ITEMS', 'TOOLS', and 'HELP'. Below this is a search bar with a dropdown menu for 'Products' and 'Literature'. The main content area features four large buttons: 'Sizing' (Enter pump sizing), 'Catalog' (Product and services), 'Replacement' (Replace an old pump with a new), and 'Liquids' (Find liquid pump). Below these buttons is a 'Quick sizing' section with input fields for 'Flow (Q)' and 'Head (H)', and a 'Select what to size by' section with radio buttons for 'Size by application', 'Size by pump design', and 'Size by pump family'. A 'START SIZING' button is located at the bottom right of the quick sizing section.

"CATALOGUE" gives you access to the Grundfos product catalogue.

"LIQUIDS" enables you to find pumps designed for aggressive, flammable or other special liquids.

All the information you need in one place

Performance curves, technical specifications, pictures, dimensional drawings, motor curves, wiring diagrams, spare parts, service kits, 3D drawings, documents, system parts. The Product Center displays any recent and saved items - including complete projects - right on the main page.

Downloads

On the product pages, you can download installation and operating instructions, data booklets, service instructions, etc. in PDF format.

Grundfos GO

Mobile solution for professionals on the GO!

Grundfos GO is the mobile tool box for professional users on the go. It is the most comprehensive platform for mobile pump control and pump selection including sizing, replacement and documentation. It offers intuitive, handheld assistance and access to Grundfos online tools, and it saves valuable time for reporting and data collection.

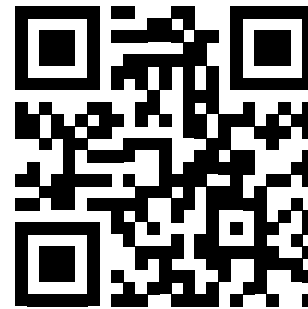
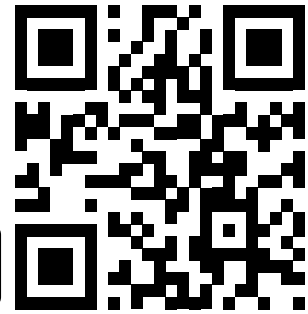

L-TP-PG-001

99701219 0120

ECM: 1278937

GRUNDFOS Chicago

3905 Enterprise Court
P.O. Box 6620
Aurora, IL 60598-0620
Phone: +1-630-236-5500
Fax: +1-630-236-5511

GRUNDFOS Kansas City

9300 Loiret Boulevard
Lenexa, Kansas 6619
Phone: +1-913-227-3400
Fax: +1-913-227-3500

GRUNDFOS CBS

902 Koomey Road
Brookshire, TX 77423
Phone: +1-281-994-2700
Fax: +1-800-945-4777

www.grundfos.us

Canada

GRUNDFOS Canada
2941 Brighton Road
Phone: +1-905-829-9533
Fax: +1-905-829-9512

www.grundfos.ca

México

GRUNDFOS México
Boulevard TLC No. 15
Parque Industrial Stiva Aeropuerto
Phone: +011-52-81-8144-4000
Fax: +011-52-81-8144-4010

www.grundfos.mx