

M50 • L50 Series Regenerative Turbine Pumps



- Capacities to 38 GPM
- Heads to 2300 Feet

 PumpCatalog.com

Questions? Call 1-800-810-1053

MTH PUMPS

M50 • L50 Series Regenerative Turbine Pumps

MTH M50 • L50 Series

Vertical, base mount, and horizontal pedestal mounted multi-stage regenerative turbine pumps represent the most economical high performance alternative for low flow (2 to 38 GPM) applications involving moderate to high pressures (heads to 2300 feet). By combining the latest concepts in hydraulic turbine pump design with precision computer controlled manufacturing, M50 • L50 Series pumps deliver high efficiency operation even at low NPSH. Costs are controlled by efficient manufacturing processes, use of standard motors, and highly optimized pump designs. Maintenance costs are kept to a minimum by combining an easily serviceable design with the use of high quality components to provide long life.

Water Passage Design

MTH masters one of the most critical design considerations of regenerative turbine pumps - the shaping of water passageways to achieve maximum capacity and pressure while minimizing horsepower requirements. By optimizing water passageway cross-sectional profiles for each impeller, MTH improves both efficiency and pressure in the M50 • L50 Series, and exceeds the standards realized by previous techniques.

Impeller Profile

One of the most notable improvements in regenerative turbine pump technology, incorporated in M50 • L50 Series pumps, involves the ability to determine the optimum impeller width and blade length. These factors have a significant effect on the

required horsepower versus pressure curve for regenerative turbine pumps. By optimizing these for each pump, peak efficiency is improved and “off peak” horsepower requirements are reduced as well.

Impeller Blades

After the most favorable impeller profile has been determined for a particular water passageway cross-section, MTH calculates the number of blades needed to maximize the performance of that pump. The blade design in M50 • L50 Series pumps increases both efficiency and design pressure without incurring the manufacturing difficulties associated with producing contoured blade impellers. State-of-the-art computer controlled machines simplify manufacturing of the various MTH impellers utilized in the M50 • L50 Series. The result is a high performance pump providing efficiency characteristics exceeding those of much more expensive units.

NPSH Requirements

M50 • L50 Series regenerative turbine pumps meet low net positive suction head (NPSH) require-

ments without efficiency loss. This is achieved by keeping the inlet fluid velocity low and then gently accelerating to passageway velocities. Special ramps are responsible for this gentle fluid entry into the impeller blades and account for the high inlet efficiency of the M50 • L50 Series pumps.

Low NPSH Requirements

L50 Series regenerative turbine pumps have exceptionally low NPSH requirements, making them ideally suited for applications where very little inlet head is available. This reduced NPSHR provided by the L50 Series is obtained by using a first stage centrifugal style impeller with inlet flow paths shaped to maintain a constant fluid velocity. This reduces entry losses to the impeller as well as maintaining efficiency. A multi-vane diffuser is used in conjunction with the centrifugal impeller for balancing radial loads and extracting the maximum pressure from the first stage. Pressure and flow produced by the NPSH inducer assures that the succeeding stages are adequately fed.

M50 • L50 SERIES

Design Features

Steep Head/Capacity Curve

Pumping capacity varies only slightly as pressure changes. Steep pressure characteristic overcomes temporary line resistances.

Self-Adjusting Impeller

M50 • L50 impellers utilize balancing holes to promote hydraulic self

centering, which eliminates the need for external adjustment. The free sliding impeller exerts no thrust load on the bearings, thereby extending service life. Self-centering is equally effective whether mounted in the horizontal or vertical position.

STANDARD MATERIALS

PART	BRONZE FITTED	ALL IRON	ALL BRONZE	STAINLESS STEEL
Inlet Cover	Cast Iron ASTM A48	Cast Iron ASTM A48	Bronze ASTM B62	Stainless Steel AISI 316
Outlet Cover	Cast Iron ASTM A48	Cast Iron ASTM A48	Bronze ASTM B62	Stainless Steel AISI 316
Impeller	Bronze ASTM B62	Carbon Steel 12L14	Bronze ASTM B62	W88 ASTM A494
Shaft	Stainless Steel AISI 416	Stainless Steel AISI 416	Stainless Steel AISI 316	Stainless Steel AISI 316
“O” Rings	Buna N	Buna N	Buna N	Viton A
Seals	Buna/Ceramic	Buna/Ni-Resist	Buna/Ceramic	Viton/Ceramic

LIMITATIONS

Discharge Pressure	1000 PSI
Seal Pressure*	200 PSI
Suction Pressure (Min.)	26" Hg Vac.
Speed	3600 RPM
Temperature	
Standard Construction	-20°F
Ceramic Seal Seat - Water	230°F
Silicon Carbide Seal Seat & External Seal Flush	250°F
Horsepower	
C3 - P3	1/3 to 3 HP
C30 - P30	5 to 30 HP

*Suction Pressure Plus a Percentage of Differential Pressure

Design Features

Mechanical Seals

Bronze fitted pumps have Buna N elastomers, carbon washer, ceramic seat, and stainless steel metal parts. Optional seats and materials are available.

1000 PSI Case Working Pressure

Rigid structure is designed for maximum casing strength.

100% Tested

Every pump is fully tested to verify performance prior to shipment.

Volatile Fluid Handling

The turbine impeller handles vapors up to 20% by volume, minimizing the possibility of vapor lock.

“O”Ring Gaskets

“O”ring gaskets are used throughout the M50 • L50 Series pumps to assure positive sealing.

Shaft

Standard shaft is of high strength 416 stainless steel.

Motors

Standard 56C face motors are utilized up to 3 Hp. 5 Hp and above are TEFC on vertical base mount units.

Best Efficiency

New pump designs optimize efficiency for each size.

Non-Cavitating

M50 • L50 Series pumps may be operated under adverse inlet conditions without audible or measurable cavitation.

Low NPSH

New inlet designs along with L50 Series inducer style pumps provide

superior fluid handling ability with low inlet head conditions.

Balanced Loads

By staggering each stage's discharge by 180°, the radial loads on the bearings are effectively balanced, and shaft deflection is thereby negligible.

Interstage Bushings

Close tolerance self-lubricating carbon bearings between each stage limit interstage leakage.



Optional Features

Construction Materials

Bronze fitted, all iron, all bronze and cast 316 stainless steel are available as stock materials.

Bearing Pedestals

All models can be pedestal mounted for flexible coupled drive.

“O”Ring Gaskets

Buna, EPR, Viton, Neoprene, and Teflon are available.

Mechanical Seals

Buna, EPR, Viton, Neoprene, and Teflon elastomers, tungsten, silicon carbide or ni-resist seats.

Flush Line

An external flush line from pump discharge to seal face (when used with the optional silicon carbide seat), allows operation in water up to 250°F.

Water Seal Connection

A tapped opening can be provided for seal flushing from an external source.

Inlet Strainer

A 90° suction strainer with a replaceable stainless steel screen is available for installation in the suction line to aid in preventing foreign material from entering the pump. A cap at the bottom of the strainer can be easily and quickly removed for screen cleaning or replacement.

L50 Series Inducer for Low NPSH



L50 Series inducer style pumps are designed specifically for applications where the net positive suction head available at the pump inlet is limited, such as in boiler feed water deaerator service.

A centrifugal style impeller with good low NPSH characteristics is utilized to lower the inlet head requirements.

This first stage impeller is used in conjunction with a multi-vane diffuser to provide the second stage regenerative turbine with adequate suction head.

L50 Series pumps can effectively handle NPSH availability as low as two feet, depending on the model and capacity.

Vertical Close Coupled

Multi-Stage (L51 • M52 • L52 • M53 • L53 • M54 • L54 • M55 • L55)

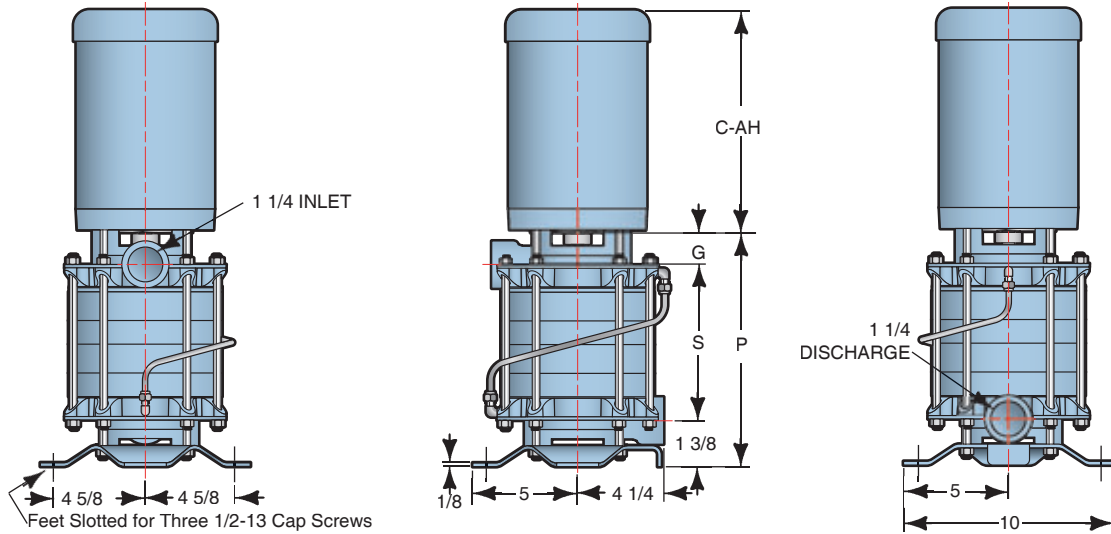

M50 PUMPS WITHOUT INDUCER

FRAME	ALL		MODEL M51		MODEL M52		MODEL M53		MODEL M54		MODEL M55		
	C-AH	G	S	P	S	P	S	P	S	P	S	P	
56C	13	13/16	SEE BELOW OR REFER TO T51 SERIES		7 1/2	10 1/16	10	12 9/16	12 1/2	15 1/16	15	17 9/16	
143T-145T	13	13/16		7 1/2	10 1/16	10	12 9/16	12 1/2	15 1/16	15	17 9/16		
182T-184T	14 1/2	13/16		7 1/2	10 1/16	10	12 9/16	12 1/2	15 1/16	15	17 9/16		
213T-215T	17	13/16		7 1/2	10 1/16	10	12 9/16	12 1/2	15 1/16	15	17 9/16		
254T-256T	21 1/2	13/16		7 1/2	10 1/16	10	12 9/16	12 1/2	15 1/16	15	17 9/16		
284TS-286TS	23 1/2	13/16		7 1/2	10 1/16	10	12 9/16	12 1/2	15 1/16	15	17 9/16		

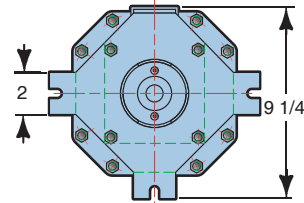

L50 PUMPS WITH INDUCER

FRAME	ALL		MODEL L51		MODEL L52		MODEL L53		MODEL L54		MODEL L55	
	C-AH	G	S	P	S	P	S	P	S	P	S	P
56C	13	2 1/4	5 15/16	9 9/16	8 7/16	12 1/16	10 15/16	14 9/16	13 7/16	17 1/16	15 15/16	19 9/16
143T-145T	13	2 1/4	5 15/16	9 9/16	8 7/16	12 1/16	10 15/16	14 9/16	13 7/16	17 1/16	15 15/16	19 9/16
182T-184T	14 1/2	2 1/4	5 15/16	9 9/16	8 7/16	12 1/16	10 15/16	14 9/16	13 7/16	17 1/16	15 15/16	19 9/16
213T-215T	17	2 1/4	5 15/16	9 9/16	8 7/16	12 1/16	10 15/16	14 9/16	13 7/16	17 1/16	15 15/16	19 9/16
254T-256T	21 1/2	2 1/4	5 15/16	9 9/16	8 7/16	12 1/16	10 15/16	14 9/16	13 7/16	17 1/16	15 15/16	19 9/16
284TS-286TS	23 1/2	2 1/4	5 15/16	9 9/16	8 7/16	12 1/16	10 15/16	14 9/16	13 7/16	17 1/16	15 15/16	19 9/16

Single Stage (M51)

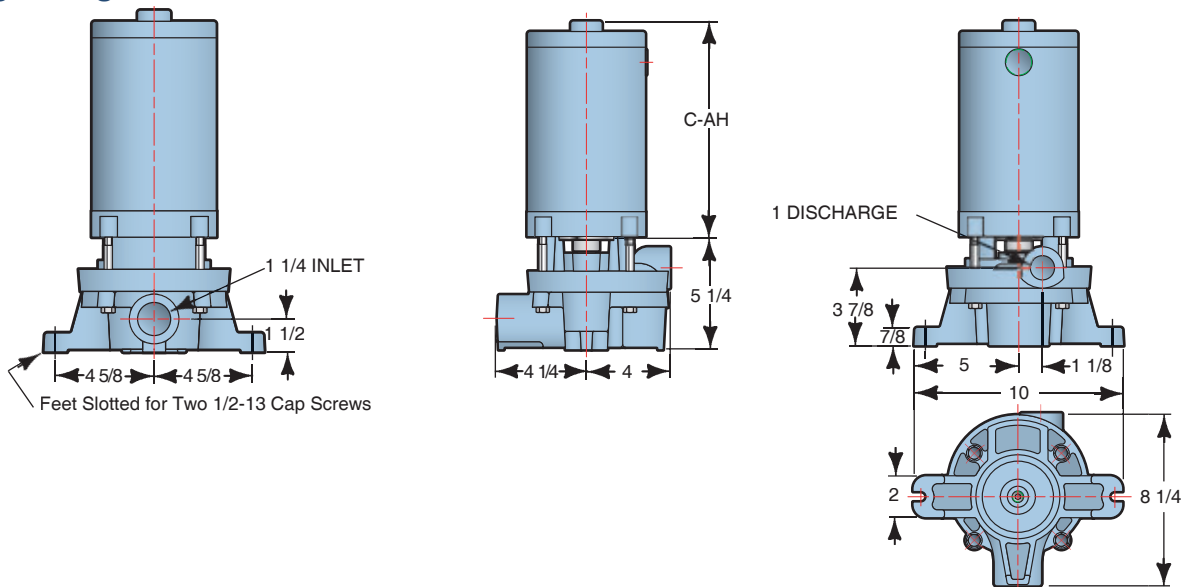

All dimensions are in inches. May vary ± 1/4 inches. Model M52 shown in Multistage Dimensions. Model M51 shown in Single Stage Dimensions.

Horizontal Close Coupled

Standard M50 Series

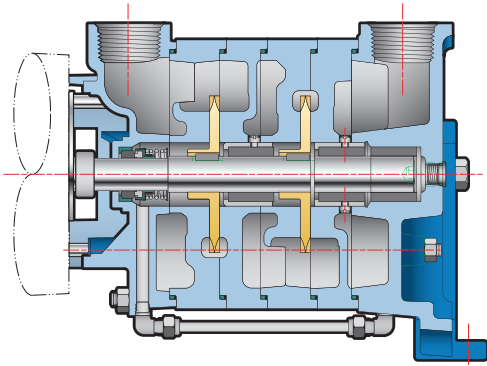

Low NPSH L50 Series

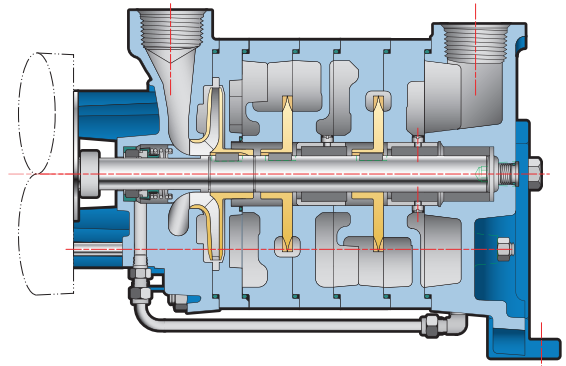

C3 Motor Frame (L51 • M52 • L52 • M53 • L53 • M54 • L54 • M55 • L55)

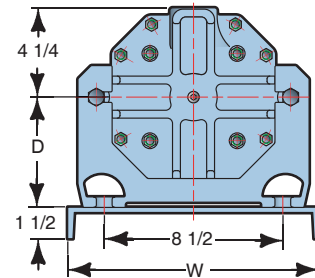
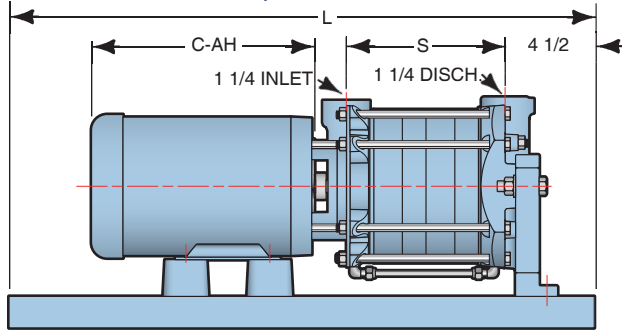

C30 Motor Frame (L51 • M52 • L52 • M53 • L53 • M54 • L54 • M55 • L55)

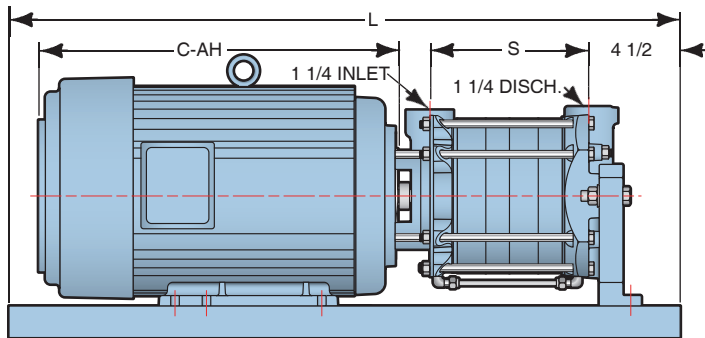

M50 PUMPS WITHOUT INDUCER

FRAME	ALL			MODEL M51			MODEL M52			MODEL M53			MODEL M54			MODEL M55		
	D	C-AH	W	S	L (C3)	L (C30)	S	L (C3)	L (C30)	S	L (C3)	L (C30)	S	L (C3)	L (C30)	S	L (C3)	L (C30)
56	5 1/4	13	12	REFER TO T51 SERIES			7 1/2	28		10	32		12 1/2	35		15	40	
143T-145T	5 1/4	13	12		7 1/2	28		10	32		12 1/2	35		15	40			
182T-184T	5 1/4	14 1/2	12		7 1/2	30	28	10	32	30	12 1/2	35	32	15	40	35		
213T-215T	5 1/4	17	12		7 1/2		32	10		35	12 1/2		40	15		40		
254T-256T	6 1/4	21 1/2	15		7 1/2		35	10		40	12 1/2		40	15		45		
284TS-286TS	7	23 1/2	15		7 1/2		40	10		40	12 1/2		45	15		45		

L50 PUMPS WITH INDUCER

FRAME	ALL			MODEL L51			MODEL L52			MODEL L53			MODEL L54			MODEL L55		
	D	C-AH	W	S	L (C3)	L (C30)	S	L (C3)	L (C30)	S	L (C3)	L (C30)	S	L (C3)	L (C30)	S	L (C3)	L (C30)
56	5 1/4	13	12	5 15/16	28		8 7/16	30		10 15/16	32		13 7/16	35		15 15/16	40	
143T-145T	5 1/4	13	12	5 15/16	28		8 7/16	30		10 15/16	32		13 7/16	35		15 15/16	40	
182T-184T	5 1/4	14 1/2	12	5 15/16	30	28	8 7/16	32	30	10 15/16	35	32	13 7/16	40	35	15 15/16	40	40
213T-215T	5 1/4	17	12	5 15/16		30	8 7/16		35	10 15/16		35	13 7/16		40	15 15/16		40
254T-256T	6 1/4	21 1/2	15	5 15/16		35	8 7/16		40	10 15/16		40	13 7/16		45	15 15/16		45
284TS-286TS	7	23 1/2	15	5 15/16		40	8 7/16		40	10 15/16		45	13 7/16		45	15 15/16		50

All dimensions are in inches. May vary ± 1/4 inches. Model M52 shown in Dimensions.

Horizontal Pedestal Mounted P3 Bearing Frame

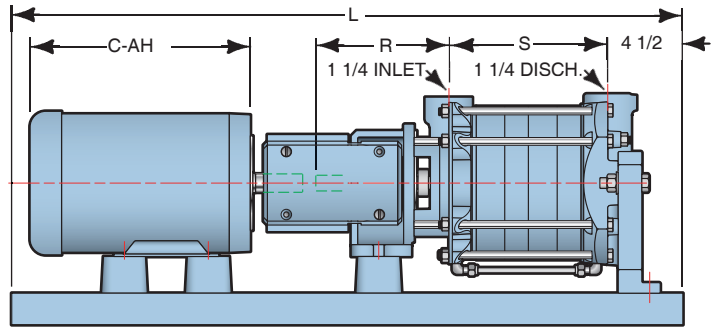
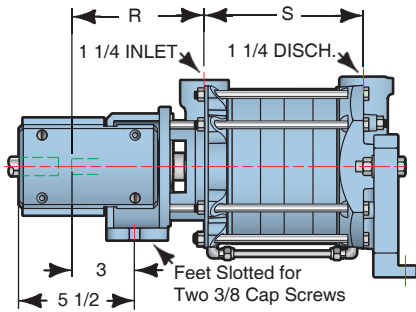

P30 Bearing Frame

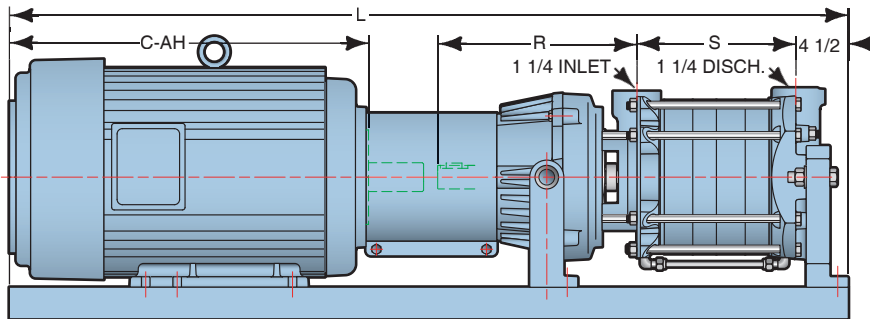
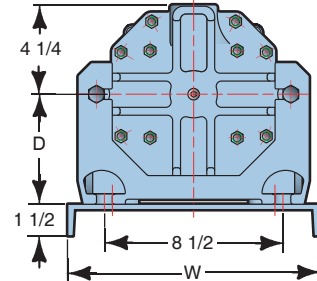
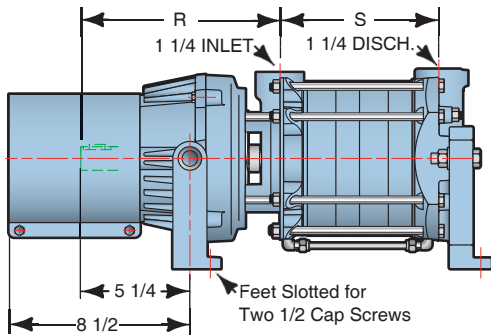

M50 PUMPS WITHOUT INDUCER

FRAME	ALL					MODEL M51			MODEL M52			MODEL M53			MODEL M54			MODEL M55			
	D	C-AH	R (P3)	R (P30)	W	S	L (P3)	L (P30)	S	L (P3)	L (P30)	S	L (P3)	L (P30)	S	L (P3)	L (P30)	S	L (P3)	L (P30)	
56	5 1/4	13	5 15/16	9 1/16	12	REFER TO T51 SERIES			7 1/2	32		10	35		12 1/2	38		15	40		
143T-145T	5 1/4	13	5 15/16	9 1/16	12		7 1/2	35		10	35		12 1/2	38		15	40				
182T-184T	5 1/4	14 1/2	5 15/16	9 1/16	12		7 1/2	35	40	10	38	45	12 1/2	40	45	15	45	50			
213T-215T	5 1/4	17	5 15/16	9 1/16	12		7 1/2		45	10		45	12 1/2		50	15		50			
254T-256T	6 1/4	21 1/2	5 15/16	9 1/16	15		7 1/2		50	10		50	12 1/2		55	15		55			
284TS-286TS	7	23 1/2	5 15/16	9 1/16	15		7 1/2		50	10		55	12 1/2		55	15		60			

L50 PUMPS WITH INDUCER

FRAME	ALL					MODEL L51			MODEL L52			MODEL L53			MODEL L54			MODEL L55		
	D	C-AH	R (P3)	R (P30)	W	S	L (P3)	L (P30)	S	L (P3)	L (P30)	S	L (P3)	L (P30)	S	L (P3)	L (P30)	S	L (P3)	L (P30)
56	5 1/4	13	7	10 1/8	12	5 15/16	32		8 7/16	35		10 15/16	38		13 7/16	40		15 15/16	45	
143T-145T	5 1/4	13	7	10 1/8	12	5 15/16	32		8 7/16	35		10 15/16	38		13 7/16	40		15 15/16	45	
182T-184T	5 1/4	14 1/2	7	10 1/8	12	5 15/16	35	38	8 7/16	38	40	10 15/16	40	45	13 7/16	45	45	15 15/16	45	50
213T-215T	5 1/4	17	7	10 1/8	12	5 15/16		45	8 7/16		45	10 15/16		50	13 7/16		50	15 15/16		55
254T-256T	6 1/4	21 1/2	7	10 1/8	15	5 15/16		50	8 7/16		50	10 15/16		55	13 7/16		55	15 15/16		60
284TS-286TS	7	23 1/2	7	10 1/8	15	5 15/16		50	8 7/16		55	10 15/16		55	13 7/16		60	15 15/16		60

All dimensions are in inches. May vary ± 1/4 inches. Model M52 shown in Dimensions.

Engineering Specifications

M Series Close Coupled

The contractor shall furnish (and install as shown on the plans) an MTH M50 Series (horizontal) (vertical base mount) close coupled regenerative turbine type pump model _____ size _____ of (BRONZE FITTED) (ALL IRON) (ALL BRONZE) (316 STAINLESS STEEL) construction. Each pump shall have a capacity of ___ GPM when operating at a total head of ___ feet. Suction pressure will be ___ feet with a liquid temperature of ___ degrees F.

The pump is to be furnished with a mechanical seal with stainless steel metal parts, (Buna) (EPR) (Teflon) (Viton) elastomers, (ceramic) (ni-resist) (silicon carbide) (tungsten carbide) seat and carbon washer. Pump will have shaft sleeve or stainless steel shaft which will prevent pumped fluid from contacting motor shaft.

The pump shall be vertically split design with replaceable external channel rings that have water passageways accurately machined into each ring. The suction and discharge will have (NPT) (SAE) (BSP) (ISO) threads located in the top vertical position for self-venting and shall be cast separately from one another. The impeller(s) shall be hydraulically self-centering and no external adjustment shall be necessary.

The pump shall be mounted to a standard NEMA ___HP ___phase ___Hertz ___ volt ___RPM (horizontal) (vertical), (open dripproof) (totally enclosed) (explosion proof) motor. Each pump shall be tested at the specified capacity and head prior to shipment. The motor shall be sized to prevent overloading at the highest head condition listed in the specifications.

L Series Close Coupled

The contractor shall furnish (and install as shown on the plans) an MTH L50 Series (horizontal) (vertical base mount) close coupled regenerative turbine type pump model _____ size _____ of (BRONZE FITTED) (ALL IRON) (ALL BRONZE) (316 STAINLESS STEEL) construction. Each pump shall have a capacity of ___ GPM when operating at a total head of ___ feet. Suction pressure will be ___ feet with a liquid temperature of ___ degrees F.

The pump is to be furnished with a mechanical seal with stainless steel metal parts, (Buna) (EPR) (Teflon) (Viton) elastomers, (ceramic) (ni-resist) (silicon carbide) (tungsten carbide) seat and carbon washer. Pump will have shaft sleeve or stainless steel shaft which will prevent pumped fluid from contacting motor shaft.

The pump shall be low NPSHR inducer style design with a centrifugal radial vane design impeller and a multi-vane diffuser for balancing radial loads. Pump shall be vertically split design with replaceable external channel rings that have water passageways accurately machined into each ring. The suction and discharge will have (NPT) (SAE) (BSP) (ISO) threads located in the top vertical position for self-venting and shall be cast separately from one another. The impeller(s) shall be hydraulically self-centering and no external adjustment shall be necessary. The pump shall be mounted to a standard NEMA ___HP ___phase ___Hertz ___ volt ___RPM (horizontal) (vertical), (open dripproof) (totally enclosed) (explosion proof) motor. Each pump shall be tested at the specified capacity and head prior to shipment. The motor shall be sized to prevent overloading at the highest head condition listed in the specifications.

M Series Flex Coupled

The contractor shall furnish (and install as shown on the plans) an MTH M50 Series horizontal pedestal mount regenerative turbine type pump model _____ size _____ of (BRONZE FITTED) (ALL IRON) (ALL BRONZE) (316 STAINLESS STEEL) construction. Each pump shall have a capacity of ___ GPM when operating at a total head of ___ feet. Suction pressure will be ___ feet with a liquid temperature of ___ degrees F. The pump is to be furnished with a mechanical seal with stainless steel metal parts, (Buna) (EPR) (Teflon) (Viton) elastomers, (ceramic) (ni-resist) (silicon carbide) (tungsten carbide) seat and carbon washer. Pump will be furnished with a shaft sleeve or stainless steel shaft and shall be vertically split design with replaceable external channel rings that have water passageways accurately machined into each ring. The suction and discharge will have (NPT) (SAE) (BSP) (ISO) threads located in the top vertical position for self-venting and shall be cast separately from one another. The impeller(s) shall be hydraulically self-centering and no external adjustment shall be necessary.

The pump shall be mounted on a bearing pedestal with sealed, grease lubricated ball bearings having a two year minimum design life under a maximum pump differential pressure of 1000 PSI, and the shaft shall be of 416 stainless steel material. Pump and motor shall be mounted on a common steel baseplate, flexible coupled with coupling guard to a standard horizontal NEMA ___HP ___phase ___Hertz ___volt ___RPM (open dripproof) (totally enclosed) (explosion

proof) motor. Coupling alignment shall be checked after installation. Each pump shall be tested at the specified capacity and head prior to shipment. The motor shall be sized to prevent overloading at the highest head condition listed in the specifications.

L Series Flex Coupled

The contractor shall furnish (and install as shown on the plans) an MTH L50 Series horizontal pedestal mount regenerative turbine type pump model _____ size _____ of (BRONZE FITTED) (ALL IRON) (ALL BRONZE) (316 STAINLESS STEEL) construction. Each pump shall have a capacity of ___ GPM when operating at a total head of ___ feet. Suction pressure will be ___ feet with a liquid temperature of ___ degrees F. The pump is to be furnished with a mechanical seal with stainless steel metal parts, (Buna) (EPR) (Teflon) (Viton) elastomers, (ceramic) (ni-resist) (silicon carbide) (tungsten carbide) seat and carbon washer.

The pump shall be low NPSHR inducer style design with a centrifugal radial vane design impeller and a multi-vane diffuser for balancing radial loads. Pump will be furnished with a shaft sleeve or stainless steel shaft and shall be vertically split design with replaceable external channel rings that have water passageways accurately machined into each ring. The suction and discharge will have (NPT) (SAE) (BSP) (ISO) threads located in the top vertical position for self-venting and shall be cast separately from one another. The impeller(s) shall be hydraulically self-centering and no external adjustment shall be necessary.

The pump shall be mounted on a bearing pedestal with sealed, grease lubricated ball bearings having a two year minimum design life under a maximum pump differential pressure of 1000 PSI, and the shaft shall be of 416 stainless steel material. Pump and motor shall be mounted on a common steel baseplate, flexible coupled with coupling guard to a standard horizontal NEMA ___HP ___phase ___Hertz ___volt ___RPM (open dripproof) (totally enclosed) (explosion proof) motor. Coupling alignment shall be checked after installation. Each pump shall be tested at the specified capacity and head prior to shipment. The motor shall be sized to prevent overloading at the highest head condition listed in the specifications.

Performance Curves

MODELS B - J

3450 RPM

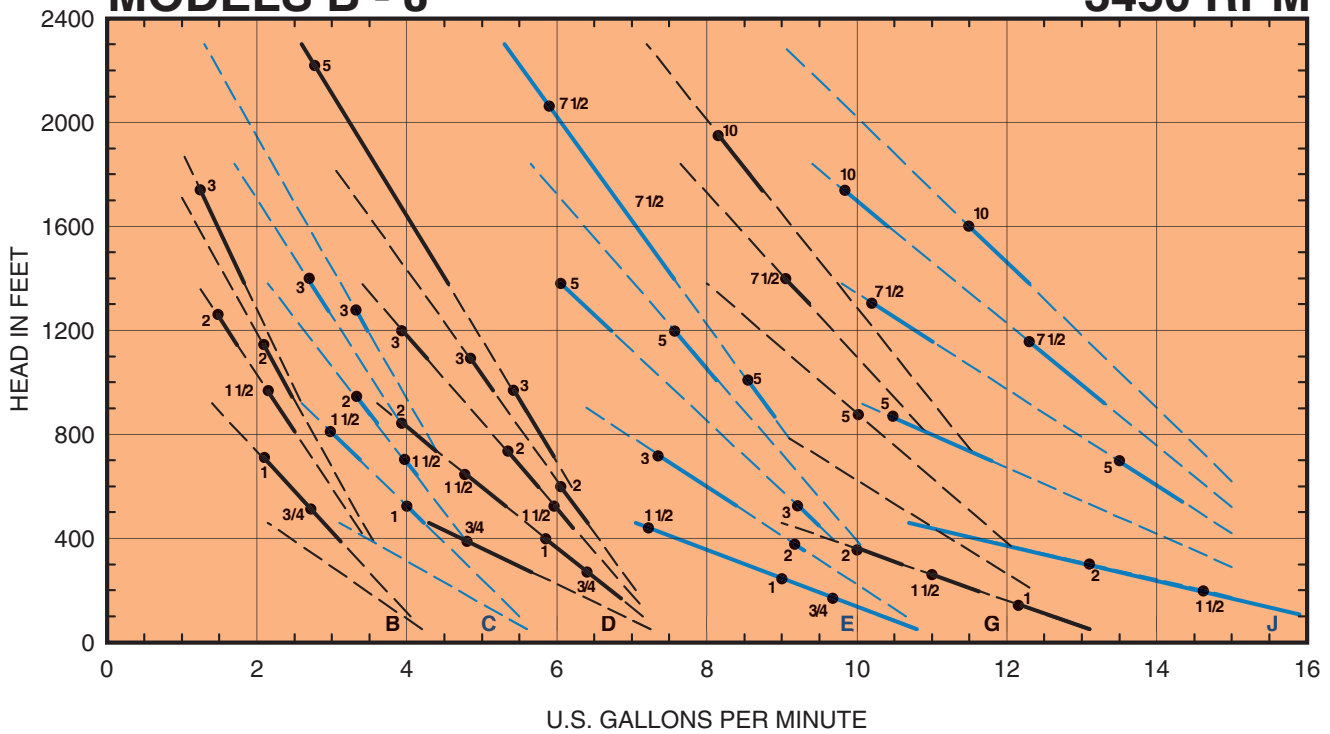

MODELS J - R

3450 RPM

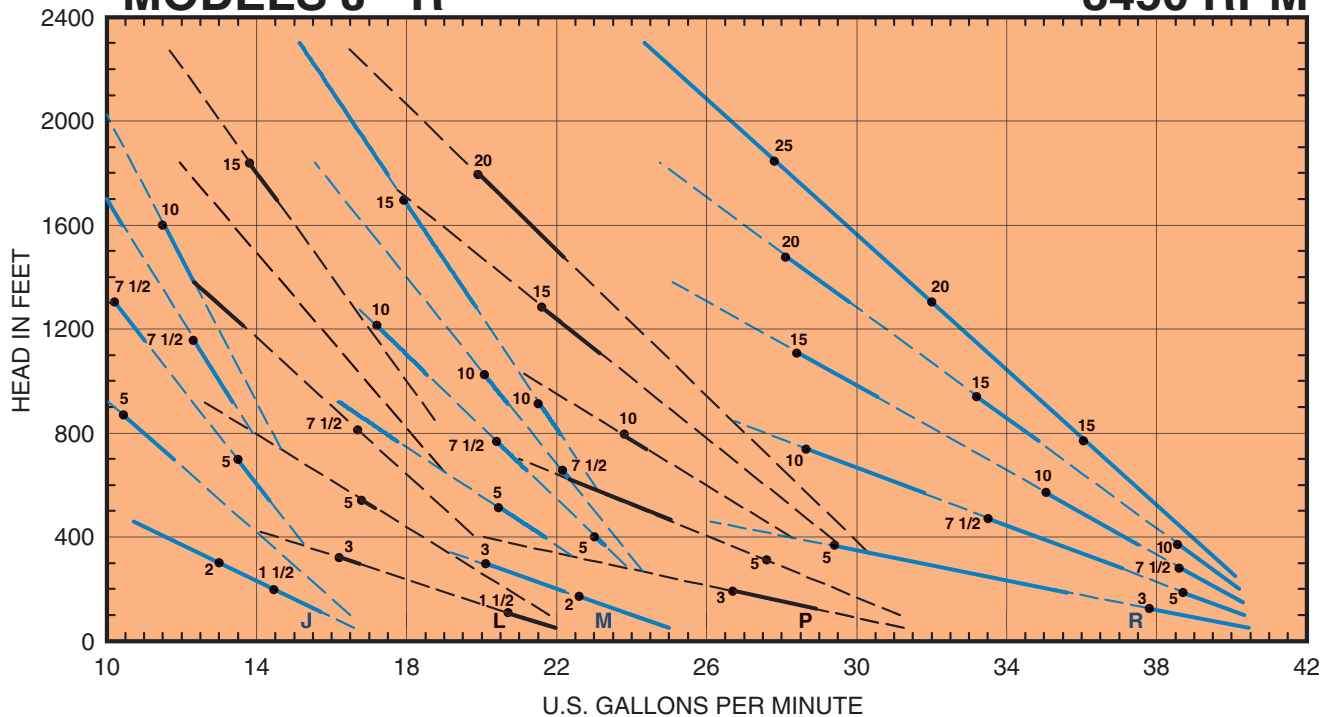

• Indicates Approximate Horsepower (Including Motor Service Factor)
 — Most Efficient Range
 - - - - - Acceptable Operating Range
 BULLETIN M50 © MTH Tool Company 2006



MTH PUMPS

401 West Main Street • Plano, IL 60545-1436
 Phone: 630-552-4115 • Fax: 630-552-3688
 Email: SALES@MTHPUMPS.COM
 http://WWW.MTHPUMPS.COM

Order Online: www.PumpCatalog.com