

Please read and save this Repair Parts Manual. Read this manual and the General Operating Instructions carefully before attempting to assemble, install, operate or maintain the product described. Protect yourself and others by observing all safety information. The Safety Instructions are contained in the General Operating Instructions. Failure to comply with the safety instructions accompanying this product could result in personal injury and/or property damage! Retain instructions for future reference. AMT reserves the right to discontinue any model or change specifications at any time without incurring any obligation.

©2024 AMT Pump Company, A Subsidiary of The Gorman-Rupp Company, All Rights Reserved.

Periodic maintenance and inspection is required on all pumps to ensure proper operation. Unit must be clear of debris and sediment. Inspect for leaks and loose bolts. Failure to do so voids warranty.

# 3 & 4-Inch Self-Priming Centrifugal Pumps



Refer to pump manual 1808-634-00 for General Operating and Safety Instructions.

## DESCRIPTION

These centrifugal pumps are self-priming (to 20 ft. lift) units for high volume liquid transfer. These units can also accommodate solids (up to 3/8" diameter), and sediment laden liquids. Casing working pressure to 100 psi (690 kPa).

The units are equipped with cast stainless steel casing, bracket, seal plate, removable volute, clog resistant semi-open impeller and a cast iron motor adapter. Units are equipped with a suction check valve to ensure self-priming. A mechanical seal isolates the motor from the liquid in the pump casing. The units are direct coupled to 3450 rpm NEMA JM shaft, totally enclosed fan cooled motors. All units are manual models, no controls are supplied. For use with nonflammable, non-abrasive liquids compatible with pump component materials.

### ▲ WARNING

**All units are for use with non-flammable, non-abrasive liquids compatible with pump component materials.**

## MAINTENANCE

### ▲ WARNING

**Make certain that the unit is disconnected and locked out from the power source before attempting to service or remove any components.**

### PERIODIC CLEANING & INSPECTION

Pump Casing (Ref. No. 5) should be removed periodically to clean out any accumulated sediment or solids.

1. Remove six hex head screws (Ref. No. 8) and lock washers (Ref. No. 9). Slide casing off bracket (Ref. No. 11).
2. Volute (Ref. No. 33) can be removed by unthreading flange nuts (Ref. No. 35) from studs (Ref. No. 34) and sliding volute out off impeller (Ref. No. 37).
3. Clean both impeller vanes and volute internal passage.
4. When replacing volute make sure sealing O-rings (Ref. No. 54) are on studs before sliding back onto bracket and installing hex flange nuts.
5. Install casing onto bracket, make sure sealing O-ring (Ref. No. 50) is in position on volute nose and O-ring (Ref. No. 49) is in place on casing. Install six hex head screws with lock washers fastening casing to bracket.

### REPLACING SHAFT SEAL

Following instructions detail procedure to change leaking mechanical shaft seal. Do Not operate pump with leaking shaft seal. Damage to motor/motor bearing will occur and is not covered by warranty.

**IMPORTANT:** Always replace both seal seat (Ref. No. 2) and seal head (Ref. No. 3) to ensure proper mating of components! Also, Impeller O-ring (Ref. No. 52) should be replaced anytime impeller screw (Ref. No 38) has been removed.

### REMOVAL OF OLD SHAFT SEAL

1. Remove six hex head screws and lock washers connecting casing to bracket. Remove casing.
2. Remove two hex flange nuts securing volute studs to bracket. Remove volute from bracket exposing impeller.
3. Remove flat head impeller screw from impeller/motor shaft. Remove impeller from motor shaft. Do not loose drive key (Ref. No. 39) it may stay in impeller or in motor shaft. Also, there is a sealing O-ring (Ref. No. 53) on shaft sleeve (Ref. No. 23) behind impeller hub do not lose it either.
4. Slide shaft sleeve and seal head (Ref. No. 3) off motor shaft (Ref. No. 1) as a unit.
5. If bracket mounting foot (Ref. No. 56) is fastened to a mounting/support surface remove two hex head screws (Ref. No. 57) and washers (Ref. No. 58).
6. Remove four hex head screws (Ref. No. 12) and lock washers (Ref. No. 13). Remove bracket assembly from seal plate/adaptor.
7. Remove seal plate (Ref. No. 30) from adaptor or from bracket if it remained there when bracket was removed.
8. Make sure any/all impeller shims (Ref. No. 40) and/or shaft collar (Ref. No. 24) remained on motor shaft.
9. Slide old shaft seal head (rotating) off shaft sleeve.
10. Remove old shaft seal seat (stationary) from seal plate cavity.
11. Thoroughly clean both the shaft sleeve and seal plate cavity, remove any old elastomer and dirt.

### INSTALL NEW MECHANICAL SHAFT SEAL

### ▲ CAUTION

**The mechanical seal precision lapped faces can easily be scratched or damaged, handle with care.**

1. Wet the rubber portion of new seal seat with a light coating of soapy water. While wearing clean gloves or using a clean light rag press seal seat squarely into seal plate recess. Avoid scratching polished seal face surface. If seal seat cannot be pressed in by hand place a cardboard washer over polished surface and use a piece of pipe to press in firmly but gently.

# 3 & 4-Inch Self-Priming Centrifugal Pumps

2. Dispose of cardboard washer if used. Check again to see that polished surface is free of dirt and all other foreign particles and that it has not been scratched or damaged. Install seal plate in adapter.
3. Replace bracket over seal plate. Fasten to adapter with four hex head screws and lock washers. Reinstall any hardware fastening foot to bracket or foot to support surface.
4. Slide the shaft sleeve, with non-oring grooved end towards motor, onto the motor shaft. Seat squarely against shims and shaft collar. Mark location of seal seat face on shaft sleeve. Remove sleeve from shaft.
5. Wet the inside of rubber portion of new seal head with a light coating of soapy water. Slide shaft seal head onto shaft sleeve with seal head face towards non-oring grooved end. Position seal head face at mark corresponding to seal seat face location.
6. Slide the shaft sleeve onto motor shaft until seal head face mates with seal seat face. This should correspond with sleeve end mating to shims and shaft collar.
7. Replace seal head spring onto seal head body if it was removed to slide head onto shaft. If a seal spring washer was supplied with replacement shaft seal discard it. Seal spring will register on impeller hub step.
8. Replace impeller hub o-ring on shaft sleeve, impeller drive key into motor shaft keyway, align impeller with drive key and slide onto motor shaft.
9. Replace impeller screw o-ring and impeller screw. Securely tighten impeller screw seating impeller hub against shaft sleeve.
10. Replace volute making sure sealing o-rings are located on studs. Fasten to bracket with two hex flange nuts.
11. Replace casing making sure sealing o-ring is located on volute inlet nose and casing diameter step. Fasten to bracket with six hex head screws and lock washers.
12. A short "run-in" period may be necessary to provide completely leak free seal operation.

## SHIM ADJUSTMENT

When installing a replacement impeller (Ref. No. 37), motor (Ref. No. 1), shaft sleeve (Ref. No. 23), or volute (Ref. No. 33) it may be necessary to adjust the number of shims (Ref. No. 40) to ensure proper running clearance between impeller and volute (Ref. No. 33). Proceed as follows:

**NOTE:** A proper running clearance between impeller vane face and volute face is 0.02" or less.

1. Replace part as needed following REPLACING SHAFT SEAL section steps until part to replace is removed.
2. Rebuild pump up to installing volute. As hex flange nuts (Ref. No. 35) are tightened securing volute to bracket spin motor shaft. If shaft seizes, impeller stops spinning, stop tightening nuts. Damage to motor bearing may occur if volute is tightened down tight against impeller. Remove volute, impeller, and shaft sleeve. Remove a shim and repeat procedure removing a shim each try until impeller spins freely when bracket is secured to bracket. If impeller spins freely when volute is secured to bracket at initial reassembly add shims until impeller hits volute then remove one shim and reassemble for final time.

**IMPORTANT:** Be sure that all parts; bracket (Ref. No. 11), seal plate (Ref. No. 30), adapter (Ref. No. 26) and motor are fitted together with metal-to-metal full contact where they meet on outside

# 3 & 4-Inch Self-Priming Centrifugal Pumps

***For Repair Parts contact dealer where pump was purchased.***

*Please provide following information:*

*-Model Number*

*-Serial Number (if any)*

*Part description and number as shown in parts list*

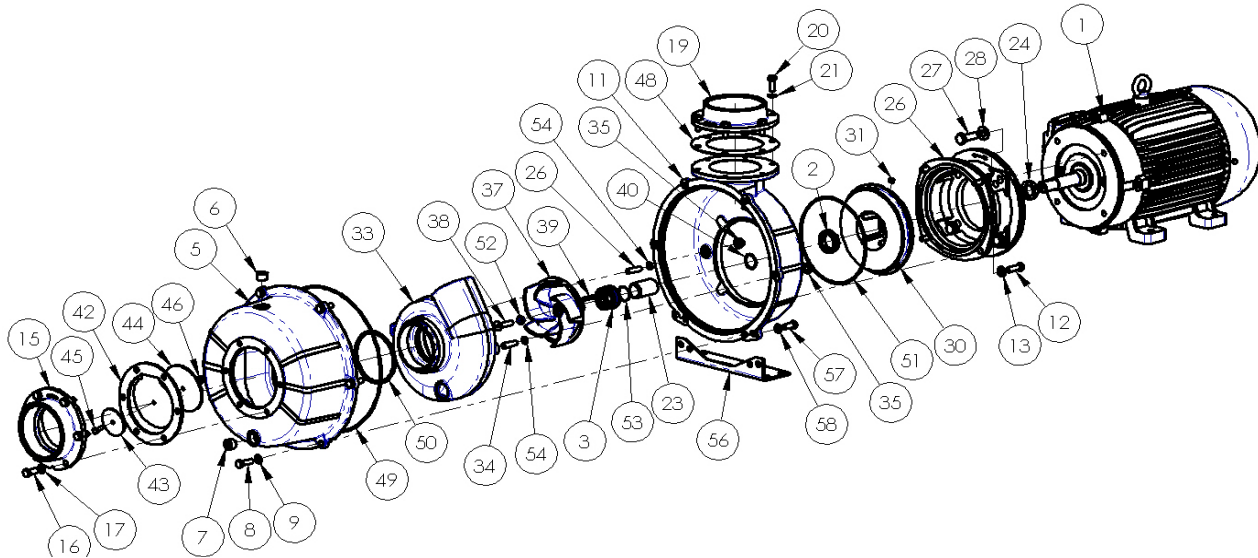

Figure 1 - Repair Parts Illustrations

# Order Online: [www.PumpCatalog.com](http://www.PumpCatalog.com)

## Repair Parts List

Ref No.	Description	Part Number for Models				Qty
		3" - 5HP	3" - 7.5HP	4" - 10HP	4" - 15HP	
		6200-98	6202-98	6210-98	6212-98	
1	Motor - 3 Phase TEFC	1627-352-00	1627-353-00	1627-354-00	1627-355-00	1
	Motor - 1 Phase TEFC	1626-078-00	1626-079-00	1626-080-00	-	1
2 & 3	Shaft Seal Assembly	1646-324-00	1646-324-00	1646-324-00	1646-324-00	1
4	Casing Kit (includes Ref. Nos. 5, 6, 7, 8 and 9)	6200-001-98	6200-001-98	6200-001-98	6200-001-98	1
5	Casing	Incl. w/Ref. 4	Incl. w/Ref. 4	Incl. w/Ref. 4	Incl. w/Ref. 4	1
6	1/2" NPT Fill Plug	Incl. w/Ref. 4	Incl. w/Ref. 4	Incl. w/Ref. 4	Incl. w/Ref. 4	1
7	1/2" NPT Drain Plug	Incl. w/Ref. 4	Incl. w/Ref. 4	Incl. w/Ref. 4	Incl. w/Ref. 4	1
8	Hex Head Screw	Incl. w/Ref. 4	Incl. w/Ref. 4	Incl. w/Ref. 4	Incl. w/Ref. 4	6
9	Lock Washer	Incl. w/Ref. 4	Incl. w/Ref. 4	Incl. w/Ref. 4	Incl. w/Ref. 4	6
10	Bracket Kit (includes Ref. Nos. 11, 12 and 13)	6200-040-98	6200-040-98	6200-040-98	6200-040-98	1
11	Bracket	Incl. w/Ref. 10	Incl. w/Ref. 10	Incl. w/Ref. 10	Incl. w/Ref. 10	1
12	Fastener	Incl. w/Ref. 10	Incl. w/Ref. 10	Incl. w/Ref. 10	Incl. w/Ref. 10	4
13	Washer	Incl. w/Ref. 10	Incl. w/Ref. 10	Incl. w/Ref. 10	Incl. w/Ref. 10	4
14	Suction Flange Kit (includes Ref. Nos. 15, 16 and 17)	6200-050-98	6200-050-98	6200-052-98	6200-052-98	1
15	Suction Flange	Incl. w/Ref. 14	Incl. w/Ref. 14	Incl. w/Ref. 14	Incl. w/Ref. 14	1
16	Hex Head Screw	Incl. w/Ref. 14	Incl. w/Ref. 14	Incl. w/Ref. 14	Incl. w/Ref. 14	6
17	Lock Washer	Incl. w/Ref. 14	Incl. w/Ref. 14	Incl. w/Ref. 14	Incl. w/Ref. 14	6
18	Discharge Manifold Kit (includes Ref. Nos. 19, 20 and 21)	6200-080-98	6200-080-98	6200-082-98	6200-082-98	1
19	Discharge Manifold	Incl. w/Ref. 18	Incl. w/Ref. 18	Incl. w/Ref. 18	Incl. w/Ref. 18	1
20	Hex Head Screw	Incl. w/Ref. 18	Incl. w/Ref. 18	Incl. w/Ref. 18	Incl. w/Ref. 18	6
21	Lock Washer	Incl. w/Ref. 18	Incl. w/Ref. 18	Incl. w/Ref. 18	Incl. w/Ref. 18	6
22	Shaft Sleeve/Collar Kit (includes Ref. Nos. 23 and 24)	6200-140-98	6200-140-98	6200-140-98	6200-140-98	1
23	Shaft Sleeve	Incl. w/Ref. 22	Incl. w/Ref. 22	Incl. w/Ref. 22	Incl. w/Ref. 22	1
24	Shaft Collar	Incl. w/Ref. 22	Incl. w/Ref. 22	Incl. w/Ref. 22	Incl. w/Ref. 22	1
25	Adapter Kit (includes Ref. Nos. 26, 27 and 28)	6200-030-95	6200-030-95	6210-030-95	6210-030-95	1
26	Adapter	Incl. w/Ref. 25	Incl. w/Ref. 25	Incl. w/Ref. 25	Incl. w/Ref. 25	1
27	Hex Head Screw	Incl. w/Ref. 25	Incl. w/Ref. 25	-	-	4
	Hex Flange Screw	-	-	Incl. w/Ref. 25	Incl. w/Ref. 25	4
28	Washer	Incl. w/Ref. 25	Incl. w/Ref. 25	-	-	4
29	Seal Plate Kit (includes Ref. Nos. 30 and 31)	6200-020-98	6200-020-98	6200-020-98	6200-020-98	1
30	Seal Plate	Incl. w/Ref. 29	Incl. w/Ref. 29	Incl. w/Ref. 29	Incl. w/Ref. 29	1
31	NPT Plug	Incl. w/Ref. 29	Incl. w/Ref. 29	Incl. w/Ref. 29	Incl. w/Ref. 29	1
32	Volute Kit (includes Ref. Nos. 33, 34 and 35)	6200-150-98	6200-151-98	6200-152-98	6200-153-98	1
33	Volute	Incl. w/Ref. 32	Incl. w/Ref. 32	Incl. w/Ref. 32	Incl. w/Ref. 32	1
34	Stud	Incl. w/Ref. 32	Incl. w/Ref. 32	Incl. w/Ref. 32	Incl. w/Ref. 32	2
35	Hex Flange Nut	Incl. w/Ref. 32	Incl. w/Ref. 32	Incl. w/Ref. 32	Incl. w/Ref. 32	2

Ref No.	Description	Part Number for Models				Qty
		3" - 5HP 6200-98	3" - 7.5HP 6202-98	4" - 10HP 6210-98	4" - 15HP 6212-98	
36	Impeller Kit (includes Ref. Nos. 37, 38, 39 and 40)	6200-010-98	6202-010-98	6210-010-98	6212-010-98	1
37	Impeller	Incl. w/Ref. 36	Incl. w/Ref. 36	Incl. w/Ref. 36	Incl. w/Ref. 36	1
38	Impeller Screw	Incl. w/Ref. 36	Incl. w/Ref. 36	Incl. w/Ref. 36	Incl. w/Ref. 36	1
39	Drive Key	Incl. w/Ref. 36	Incl. w/Ref. 36	Incl. w/Ref. 36	Incl. w/Ref. 36	1
40	Impeller Shim	Incl. w/Ref. 36	Incl. w/Ref. 36	Incl. w/Ref. 36	Incl. w/Ref. 36	Varies
41	Check Valve Assembly (includes Ref. Nos. 42, 43, 44, 45 and 46)	6200-070-90	6200-070-90	6200-070-90	6200-070-90	
42	Check Valve	Incl. w/Ref. 41	Incl. w/Ref. 41	Incl. w/Ref. 41	Incl. w/Ref. 41	1
43	Weight External	Incl. w/Ref. 41	Incl. w/Ref. 41	Incl. w/Ref. 41	Incl. w/Ref. 41	1
44	Weight Internal	Incl. w/Ref. 41	Incl. w/Ref. 41	Incl. w/Ref. 41	Incl. w/Ref. 41	1
45	Hex Head Bolt	Incl. w/Ref. 41	Incl. w/Ref. 41	Incl. w/Ref. 41	Incl. w/Ref. 41	1
46	Hex Flange Nut	Incl. w/Ref. 41	Incl. w/Ref. 41	Incl. w/Ref. 41	Incl. w/Ref. 41	1
47	Gasket Kit - Viton (includes Ref. Nos. 37, 38, 39 and 40)	6200-300-90	6200-300-90	6200-300-90	6200-300-90	1
48	Discharge Gasket	Incl. w/Ref. 47	Incl. w/Ref. 47	Incl. w/Ref. 47	Incl. w/Ref. 47	1
49	Casing O-Ring - Viton	Incl. w/Ref. 47	Incl. w/Ref. 47	Incl. w/Ref. 47	Incl. w/Ref. 47	1
50	Volute O-Ring - Viton	Incl. w/Ref. 47	Incl. w/Ref. 47	Incl. w/Ref. 47	Incl. w/Ref. 47	1
51	Bracket O-Ring - Viton	Incl. w/Ref. 47	Incl. w/Ref. 47	Incl. w/Ref. 47	Incl. w/Ref. 47	1
52	Impeller O-Ring - Viton	Incl. w/Ref. 47	Incl. w/Ref. 47	Incl. w/Ref. 47	Incl. w/Ref. 47	1
53	Shaft Sleeve O-Ring - Viton	Incl. w/Ref. 47	Incl. w/Ref. 47	Incl. w/Ref. 47	Incl. w/Ref. 47	1
54	Volute Stud O-Ring - Viton	Incl. w/Ref. 47	Incl. w/Ref. 47	Incl. w/Ref. 47	Incl. w/Ref. 47	2
55	Mounting Foot Kit (includes Ref. Nos. 56, 57 and 58)	6200-100-98	6200-100-98	6200-100-98	6200-100-98	1
56	Mounting Foot	Incl. w/Ref. 55	Incl. w/Ref. 55	Incl. w/Ref. 55	Incl. w/Ref. 55	1
57	Hex Head Screw	Incl. w/Ref. 55	Incl. w/Ref. 55	Incl. w/Ref. 55	Incl. w/Ref. 55	2
58	Washer	Incl. w/Ref. 55	Incl. w/Ref. 55	Incl. w/Ref. 55	Incl. w/Ref. 55	2

Order Online: [www.PumpCatalog.com](http://www.PumpCatalog.com)





AMT Pump Company  
(herein "AMT")  
400 Spring Street  
Royersford, PA 19468  
Phone: (610) 948-3800  
Fax: (610) 948-5300  
www.amtpump.com



## General Information

**SALES POLICY:** AMT products are sold through our established Distributors. We do not sell direct to the consumer or organization not entitled to trade recognition. Therefore, possession of our catalogs and/or price list(s) does not infer an offer to sell.

**MINIMUM ORDER:** We appreciate your order, however, all orders are subject to a minimum \$35.00 net invoice charge (excluding freight). This applies to all pump and parts purchase orders.

**PRICES:** Prices are subject to change without notice. All orders accepted are subject to prices in effect at time of shipment.

**PAYMENT TERMS:** Terms, upon establishment of credit, are Net 30 days. Past due accounts may be subject to a service charge of 1.5% per month. Domestic or assignable letter of credit is required for all export trade.

**PAST DUE ACCOUNTS:** AMT reserves the right to withhold open account shipments on any past due account. Invoices are considered past due after thirty (30) days. In the interest of sound business, all orders are subject to approval of the Credit Department.

**SHIPPING INSTRUCTIONS:** All shipments will be made F.O.B. the factory. Where instructions for shipment do not appear on the order, the shipment will be made according to our best judgment. Full risk of loss (including transportation delays and losses) shall pass to the customer upon delivery of the products to the carrier at the F.O.B. point. When loss or delay occurs, primary responsibility for tracing rests with the customer. When there is LOSS or APPARENT VISIBLE DAMAGE to a shipment, when tendered for delivery, *DO NOT* give the carrier a clear receipt. Note such damage on the carrier's delivery receipt and *HAVE THE DRIVER SIGN THE RECEIPT.*

**PRODUCT REVISIONS:** AMT reserves the right to discontinue, change or improve its products or any portions thereof without being obligated to provide such a change or improvement for units sold and/or shipped prior to such a change or improvement.

## 12 Month Limited Warranty

### EXTENT AND DURATION OF LIMITED WARRANTY

**Coverage:** AMT Pump Company (herein "AMT") or IPT Pumps by Gorman-Rupp (herein "IPT") or Gorman-Rupp Industries Division of the The Gorman-Rupp Company, Patterson, or the Gorman-Rupp Company (herein referred to as "G-R Unit") each individually warrants that its products and parts shall be free from defects in material and workmanship for twelve (12) months from the date of purchase by the original end user when installation is made and maintenance is performed in accordance with G-R Unit's recommendations. Wear and tear resulting from use and items normally consumed in use are not covered.

### EXCEPTIONS

( A ) This Limited Warranty shall not apply to mechanical seals in AMT or IPT pumps and the following products and parts: engines, motors, trade accessories and all other products, components, parts and materials not manufactured by the G-R Units. These items may, however, be covered by the warranties of their respective manufacturers. ( B ) This warranty does not extend to or apply to any unit which has been repaired or altered at any place other than by a G-R Unit, or by persons not expressly approved by a G-R Unit to make repairs or alterations, nor to any unit the serial number, model number or identification of which has been removed, defaced or altered. ( C ) This warranty does not extend to any product manufactured by a G-R Unit, which has been subjected to mis-use, neglect, accident, improper installation, or use in violation of instructions furnished by a G-R Unit. ( D ) Pump Kits: This warranty does not extend to any product sold by a G-R Unit unassembled as a Pump Kit. Pump Kits are warranted against defects in material and workmanship for 60 days from the date of shipment from a G-R Unit. Any Pump Kit parts deemed defective by a G-R Unit will be replaced free of charge within 60 days of shipment. Pump Kits are not returnable for credit.

### LIMITATIONS

**THE G-R UNITS' SOLE AND EXCLUSIVE WARRANTY WITH RESPECT TO THEIR PRODUCTS AND PARTS IS THIS LIMITED WARRANTY. THIS LIMITED WARRANTY IS IN LIEU OF ALL OTHER EXPRESS AND/OR IMPLIED WARRANTIES, INCLUDING IMPLIED WARRANTIES OF MERCHANTABILITY AND FITNESS FOR PARTICULAR PURPOSE.**

### EXCLUSIVE REMEDY AND DAMAGES

The sole and exclusive remedy for breach of this Warranty by a G-R Unit and the entire extent of its liability for such breach or for damages arising from the use of the products and parts covered under this Limited Warranty, shall be as follows:

**LEAD TIME:** Products designated "Quick Ship Product", also referred to as "QSP" will normally be shipped within 24 hours of receipt of a non-cancellable purchase order. Only limited quantities of "QSP" pumps are available.

**STANDARD LEAD TIME:** Lead time is two weeks for all non "QSP" product. AMT reserves the right to revise lead times as required due to availability of materials and all other causes beyond our control.

**VIP SHIPMENT:** Select AMT and IPT branded pumps are available for next day shipment for non-QSP (Quick Ship Products) items and subjected to a specific model surcharge per unit noted in the respective price book. Requires calling for availability, confirmation and a non-cancellable purchase order or credit card payment prior to shipment. The expedited shipping charges are an additional cost added separately from the VIP charges per item. AMT reserves the right to revise lead times as required due to availability of materials and all other causes beyond our control. QSP quantities are limited as determined by AMT.

ALL purchase orders must be submitted via hard copy sent to AMT customer service department by fax, EDI or e-mail.

**RETURN GOODS POLICY:** Goods shall not be returned without a return goods authorization number (RGA) issued by AMT customer service. The RGA number must be listed on the packing list. Only current model and part numbers with a valid date code may be returned (within one year from date of purchase). **A 20% restocking and packaging charge will apply to all returns. All shipping charges must be pre-paid. No exceptions.**

**ORDER CHANGES BY CUSTOMER:** Orders in process may not be changed except with written consent and may be subject to special charges.

- Repair or Replacement:** If inspection shows that any G-R Unit product or part covered under this Limited Warranty is defective in materials or workmanship, the G-R Unit shall repair or replace the defective or non-conforming product or part without charge, whichever the G-R Unit chooses. You must have properly maintained and used the product or part claimed to be defective in accordance with the maintenance schedule or manual, which comes with the product. No allowance will be made for labor, installation, removal, transportation or other charges incurred by you in connection with such repair or replacement.
- To obtain the above remedy:
  - Immediately notify the G-R Unit upon discovery of the claimed defect in materials or workmanship and provide the serial number or date code of the product and/or part(s) or provide the G-R Unit with the invoice or bill of sale referencing the product by no later than the expiration date of the warranty period.
  - The G-R Unit will advise whether inspection will be necessary and how whether repair or replacement will be made. If inspection by the G-R Unit is necessary, the pump or defective part must be sent freight pre-paid to the G-R Unit. Return shipment will be F.O.B. the G-R Unit's plant.
  - Return Goods Authorization Requirement:** No product will be accepted for return or replacement without the prior written authorization of the G-R Unit. Upon such authorization, and in accordance with instructions from the G-R Unit, the product will be returned to the G-R Unit, shipping charges prepaid by the Buyer.

**3. Damages:** The G-R Unit's liability for damages for breach of this Limited Warranty shall not exceed the amount of the purchase price of the product or part(s) in respect to which Such damages are claimed. **IN NO EVENT SHALL THE G-R UNITS BE LIABLE FOR INCIDENTAL, CONSEQUENTIAL OR SPECIAL DAMAGES FOR BREACH OF THIS LIMITED WARRANTY.**

Some states do not allow the exclusion or limitation of incidental or consequential damages, so the above limitation or exclusion may not apply to you. This Limited Warranty gives you specific legal rights, and you may also have other rights, which vary from state to state.



**A Gorman-Rupp Company**

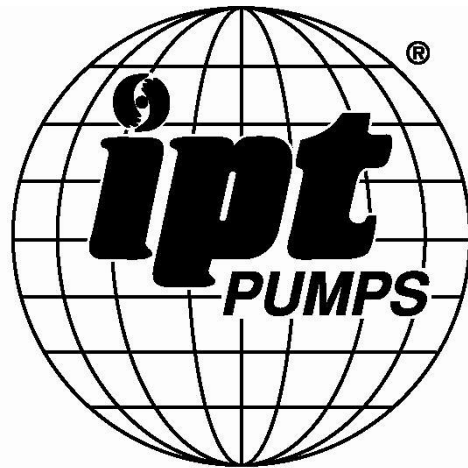

BY  
**GORMAN-RUPP®**

[www.amtpump.com](http://www.amtpump.com)

Order Online: [www.PumpCatalog.com](http://www.PumpCatalog.com)